

Riva

OWNER'S MANUAL

RIVAMARE CENTO

This manual has been drafted in compliance with standard UNI EN ISO 10240.
Any reprinting, either in whole or in part, without prior written approval by **FERRETTI S.p.A.** is strictly prohibited.
This manual has been issued by **FERRETTI S.p.A.**



A FERRETTIGROUP BRAND

Registered offices:

Via Irma Bandiera, 62
47841 Cattolica – Rimini – Italy
Tel. +39.0541.839611
Fax +39.0541.839625

Administrative headquarters:

Via Ansaldo, 7
47100 Forlì – Italy
Tel. +39.0543.474411
Fax +39.0543.782410
www.ferrettigroup.com

www.riva-yachts.com
customerservice@riva-yachts.com

1 - FOREWORD

1.1 GENERAL INFORMATION 2

 1.1.1 Introduction to the use of the manual..... 2

1.2 MANUAL INTRODUCTION..... 3

 1.2.1 Service request procedure - warranty..... 6

1.3 KNOW YOUR RESPONSIBILITY AS OWNER..... 7

1.4 NOTICES 8

1.5 SPECIFIC SAFETY WARNINGS 9

1.6 CERTIFICATION, CLASSIFICATION AND IDENTIFICATION 10

 1.6.1 Yacht identification specifications 11

1.7 LOAD-CARRYING CAPACITY..... 12

2 - SAFETY

2.1 SAFETY RULES AND WARNINGS 16

 2.1.1 Use-related rules..... 18

 2.1.2 Maintenance rules..... 20

 2.1.3 Fire prevention rules 24

2.2 NOTES ON THE ENVIRONMENT 27

 2.2.1 Regulations for waste disposal 28

2.3 SAFETY EQUIPMENT 29

 2.3.1 Arrangement of safety equipment..... 30

 2.3.2 Arrangement of fire prevention equipment..... 31

 2.3.3 Self-inflatable life raft 32

 2.3.4 Individual life jacket..... 35

 2.3.5 Life buoy 37

 2.3.6 First aid kit..... 38

 2.3.7 Signalling rockets..... 39

 2.3.8 Emergency boarding system 40

 2.3.9 Portable fire extinguishers 41

2.4 MAN OVERBOARD RECOVERY 44

2.5 ESCAPE ROUTES..... 45

 2.5.1 Abandonment of the yacht..... 47

2.6 FORBIDDEN AREAS 48

2.7 FIRE-FIGHTING SYSTEM..... 52

 2.7.1 Automatic fire-fighting system..... 53

 2.7.2 Maintenance fire protection system 59

 2.7.3 Essential restoring for resuming navigation 61

2.8 ALARM DEVICES 62

2.9 NAVIGATION LIGHTS AND DAYLIGHTS SIGNALS 63

 2.9.1 Navigation lights..... 63

 2.9.2 Daylights signals 66

2.10 MANDATORY SAFETY EQUIPMENT 68

2.11 LOCATION OF SAFETY PLATES..... 69

2.12 SCHEDULE..... 70

3 - DESCRIPTION OF THE YACHT

3.1 MAIN DIMENSIONS AND CHARACTERISTIC DATA OF THE YACHT 72

3.2 GENERAL YACHT LAYOUT AND SECTORS..... 75

3.3 MAIN DECK 76

3.4 LOWER DECK..... 79

3.5 ENGINE ROOM AND TECHNICAL ROOM 83

4 - HELM POSITION

4.1 HELM POSITION 88

 4.1.1 Front section 91

 4.1.2 Port section 92

 4.1.3 Starboard section..... 93

 4.1.4 Battery switches panel..... 94

4.2 INSTRUMENTATION 95

 4.2.1 VHF-DSC Radiotelephone..... 95

 4.2.2 Engine control levers 98

 4.2.3 Steering wheel 99

 4.2.4 Chartplotter / echosounder 99

 4.2.5 Bow thruster control panel 100

 4.2.6 Magnetic compass 101

5 - WATER SYSTEMS

5.1	FRESH WATER SYSTEM.....	104
5.1.1	Cold fresh water system	108
5.1.2	Hot fresh water system	110
5.1.3	Maintenance fresh water system	111
5.2	GREY WATER SYSTEM.....	114
5.2.1	Grey water system maintenance	117
5.3	BLACK WATER SYSTEM.....	118
5.3.1	Maintenance of black water draining system	121
5.3.2	WC operation	124
5.4	SCUPPERS SYSTEM.....	126
5.5	BILGE SYSTEM.....	128
5.5.1	Maintenance of bilge automatic suction system	131
5.6	SEAWATER SYSTEMS	133
5.6.1	Maintenance of sea cocks and strainers.....	136

6 - ELECTRIC SYSTEM

6.1	ELECTRIC SYSTEM.....	140
6.1.1	Maintenance of the electric system.....	145
6.2	ELECTRICAL PANELS	146
6.3	BATTERY SET	152
6.3.1	Checking and maintaining batteries.....	154
6.4	BATTERY BREAKER.....	156
6.5	BATTERY CHARGER	158
6.5.1	Battery charger maintenance.....	160
6.6	SHORE ELECTRIC SUPPLY	162
6.7	FUSE.....	165
6.8	GENERATOR.....	166
6.8.1	Generator control panel	170
6.8.2	Generator maintenance	171
6.9	SACRIFICIAL ANODES	174
6.9.1	Checking and maintenance of sacrificial anodes.....	175

7 - PROPULSION SYSTEMS

7.1	MAIN PROPULSION SYSTEM.....	178
7.1.1	Engine control panel	179
7.1.2	Start of propulsion engines	179
7.1.3	Check after engine start up.....	181
7.1.4	Stop of propulsion engines	181
7.1.5	Emergency stop of propulsion engines.....	182
7.1.6	Propulsion engine maintenance.....	184
7.2	STERN DRIVE	186
7.3	PROPELLERS	186
7.3.1	Propellers check and maintenance.....	186
7.3.2	Disassembly and reassembly of propellers	188
7.4	ENGINE GAS EXHAUST DUCTS	189
7.5	FUEL SYSTEM	190
7.5.1	Fuel quality.....	193
7.5.2	Water/fuel separator filter for engine.....	194
7.5.3	Fuel system maintenance.....	196
7.6	BOW THRUSTER	197

8 - STEERING SYSTEMS

8.1	STEERING SYSTEM	200
8.1.1	Trim range.....	202
8.2	INTERCEPTORS SYSTEM	204
8.3	GYROSCOPIC STABILIZER	206

9 - AIR CONDITIONING AND VENTILATION

9.1	AIR CONDITIONING SYSTEM.....	208
9.1.1	Air conditioning system maintenance	210
9.2	VENTILATION SYSTEM.....	211

10 - AUXILIARY EQUIPMENT ON BOARD

10.1	PREPARATION FOR MOORING.....	216
10.2	ANCHOR WINCH	218
10.2.1	Anchor winch maintenance.....	222

10.3	GANGWAY	223
10.3.1	Gangway system maintenance	229
10.4	STERN PLATFORM	230
10.5	WINDSCREEN WIPER SYSTEM	232
10.5.1	Windscreen wiper system maintenance	233
10.6	BIMINI	234
10.7	COCKPIT TABLE	237
10.8	SWIM LADDER	238
10.8.1	Swim ladder maintenance	241

11 - INFORMATION FOR USE

11.1	GENERAL INFORMATION	244
11.2	PRECAUTIONS FOR HARSH CLIMATES	245
11.2.1	Cooling system	245
11.2.2	Fuel system	246
11.3	PREPARING FOR NAVIGATION	247
11.3.1	Weather	248
11.4	FIRST PERIOD OF USE	249
11.4.1	Engine drive	250
11.4.2	Refuelling	252
11.5	WATER SUPPLY	254
11.6	MOORING AND UNMOORING	255
11.6.1	Leaving the mooring	256
11.6.2	Mooring manoeuvre	256
11.6.3	Mooring without people on board	257
11.7	OPERATION AND PRECAUTIONS AT SEA	258
11.8	SUGGESTIONS FOR NAVIGATION UNDER SPECIAL CONDITIONS	261
11.8.1	Navigation with bad weather conditions	261
11.8.2	Navigation with one only engine	263
11.9	TOWING THE YACHT	264
11.10	YACHT STEERING RULES	266
11.11	PREPARATION FOR ANCHORING	268
11.12	HAULAGE AND LAUNCH	269

12 - HULL AND FURNITURE MAINTENANCE

12.1	GENERAL MAINTENANCE OUTLINES	274
12.2	LONG PERIODS OF YACHT INACTIVITY	276
12.3	RE-USE OF THE YACHT AFTER A LONG INACTIVITY	279
12.4	HULL MAINTENANCE	280
12.4.1	Bottom hull	282
12.5	GENERAL MAINTENANCE	283
12.6	MAINTENANCE AND CARE OF VARNISHED WOODEN PARTS	295
12.7	SPEED MULTISENSOR (LOG) MAINTENANCE	298

13 - TROUBLESHOOTING

13.1	GENERAL NOTES	300
13.2	PROPULSION ENGINES	301
13.3	STERN DRIVE	305
13.4	BATTERY CHARGER	306
13.5	USES	308
13.6	FUEL SYSTEM	309
13.7	WASTE WATER DRAINING SYSTEM	310
13.8	FRESH WATER SYSTEM	311
13.9	BILGE PUMPS	312
13.10	GENERATOR	314
13.11	BOW THRUSTER	316
13.12	GANGWAY SYSTEM	317



Riva

RIVAMARE CENTO

Riva

RIVAMARE CENTO

FOREWORD

CHAPTER 1

1.1 GENERAL INFORMATION

NAME OF THE YACHT _____ **RIVAMARE CENTO**
 TYPE OF YACHT _____ **MOTOR YACHT**
 PROJECT CATEGORY _____ **B**

For specific interventions it is advisable to request the service of specialized technicians or contact our Service Department.

For an easy and quick consulting, the manual is subdivided in the following sections:

- FOREWORD
- SAFETY
- DESCRIPTION OF THE YACHT
- HELM POSITION
- WATER SYSTEMS
- ELECTRIC SYSTEM
- PROPULSION SYSTEMS
- STEERING SYSTEMS
- AIR CONDITIONING AND VENTILATION
- AUXILIARY EQUIPMENT ON BOARD
- INFORMATION FOR USE
- HULL AND FURNITURE MAINTENANCE
- TROUBLESHOOTING



CAUTION

Category B: A category B yacht is considered suitable to operate with winds of Beaufort force equal to or greater than 8 and significant wave height up to 4 metres.

While such conditions typically occur on extended offshore voyages, they may also arise on coastal areas where shelter is not always readily available.

These conditions may also be experienced on inland seas of sufficient size to generate a particular wave height.

Depending on the weather conditions, winds can blow up to about 27 m/s.

1.1.1 Introduction to the use of the manual

Prior to operate the yacht and the equipment on board, read the manual carefully, in order to acquire an adequate familiarity with the systems and their operation, so as to avoid hazard to personnel and risks of costly damages.

A great passion for sea and the prestige of this yacht are elements that encourage constant and regular maintenance to ensure long periods of cruising, a long life span and an ensuing improvement in safety.

The maintenance operations described in the manual are simple, but should be performed by authorised and qualified technical staff only, according to standard procedures and in compliance with national and international regulations.



CAUTION

Please keep this manual carefully in a safe, dry and easily accessible place for an easy consultation. When you decide to change the yacht, deliver this manual to the new owner in its integrity.

1.2 MANUAL INTRODUCTION

The documentation provided by RIVA to the Owner consists of two types of documents:

- The “**Owner’s Manual**”, edited by experienced professional staff in compliance with the regulations in force;
- The **Technical Document Collection**, concerning the on-board devices/systems (engines, air conditioning, etc..): it consists in a series of independent manuals, delivered by the relevant Manufacturer and/or Suppliers.

The Owner’s manual is the Main Document and must be read in whole, in any case before considering the documents in the Technical Document Collection.

The associated Technical Documentation Collection makes up the set of the Reference Documents that are required to complete the information provided in the Owner’s Manual.

Since these documents are independent and aimed at giving information on specific single components, it is necessary to refer to them when indicated by the Main Document.



CAUTION

RIVA recommends carefully reading the whole documentation delivered by the Manufacturers of the various components.

For all problems concerning the use and the maintenance of components you can refer directly to the Service Departments listed in the documents delivered by the Manufacturers.

Anyway, in case of need, some little interventions can be carried out by the staff on board, after consulting the operation manual.

This manual has been realized by RIVA in their mother language (Italian) and translated into other languages, to satisfy the customer’s requirements, and has been issued with the purpose of assisting you with the use of your yacht in full safety and with complete satisfaction.

This manual contains a detailed description of the yacht, of the systems and devices installed and practical information about its use and maintenance.

Always use trained and competent people for maintenance, repair and modifications. The changes that may affect the safety features of the yacht should be evaluated, carried out and documented by competent people. The manufacturer of the yacht can not be held responsible for changes that are not approved.

We recommend that you carefully read through this manual so as to become familiar with its contents before starting to cruise for the first time.

If this is your first yacht, or if this is a type of yacht that you are not familiar with, for your safety and to ensure your maximum satisfaction, make sure you have acquired sufficient experience about how to use and operate the yacht, before “taking the command”.



CAUTION

Make sure that the conditions of wind and sea correspond to the design category of your yacht and that you and your crew are capable of manoeuvring the yacht in such conditions.

Even when your yacht is classified accordingly, the conditions of sea and wind corresponding to design categories A, B and C ranging from storm conditions for category A to the conditions of wind and sea strong for the upper limit of category C, exposed to the dangers of a tidal wave or a wind gust.

These are therefore dangerous conditions, where only a competent crew, coached and trained on well-maintained yacht can operate satisfactorily.

THIS MANUAL MUST BE STORED AND WILL ALWAYS BE ON THIS YACHT AT EVERY TRANSFER OF PROPERTY.
SANCTIONS ARE ENVISAGED IF THE YACHT IS NOT EQUIPPED WITH THE "OWNER'S MANUAL".

IN CASE YOU LOSE OR DAMAGE THIS MANUAL, **RIVA** WILL ALWAYS BE ABLE TO SUPPLY YOU WITH A NEW COPY OF IT.



CAUTION

RIVA declines all responsibility for any damage to third parties due to discrepancies between the manual and reality.



CAUTION

This manual contains pictures of details not representing completely our yacht or with colours not corresponding to your arrangements. This is mainly due to the fact that it is possible to encounter problems during the realization of details' photos, like bed covers and sofas, which are defined only shortly before yacht delivery and therefore when the manual itself has already been issued.



CAUTION

In some countries, a license or permit to drive are required or specific regulations are in force.

This yacht may be conducted exclusively by authorized personnel to command and to the conduct of pleasure yacht in relation to the same class of the yacht.



CAUTION

All yachts, regardless of their strength, may undergo serious damage if used improperly.

This is not compatible with safe navigation.

Always adjust the speed and course of the yacht under the terms of sea.



CAUTION

If the yacht is equipped with a life raft, carefully read the operating manual. The yacht should have on board the appropriate safety equipment (life jackets, safety line, etc..) depending on the type of yacht, to the weather conditions, etc..

This equipment is mandatory in some countries.

The crew should be familiar with the use of all safety equipment and emergency manoeuvring (man overboard recovery, towing, etc..), cruising schools and clubs regularly organize training sessions.



CAUTION

All persons should wear a suitable buoyancy aid (life jacket / personal flotation equipment) when they are on the deck.

Note that, in some countries, it is a legal requirement to always wear a buoyancy aid that complies with the applicable regulations.

1.2.1 Service request procedure - warranty

The extensive RIVA service network is glad to provide you with any information regarding issues not addressed by the manual. Customers may contact Dealers, Sale Offices, Service Centres or directly:

RIVA AFTER SALES & SERVICE DEPARTMENT
 Via Ansaldo 7 - 47100
 Forlì - Italy
 Tel +39 0543 474445
 Fax +39 02 70058589
 customer.service@riva-yacht.com

RIVA has carefully selected all main components and accessories installed aboard your yacht, choosing among the most reliable manufacturers who, by offering a wide service network, also guarantee a speedy availability of spare parts.

 **CAUTION**

For all aspects related to the warranty of the yacht, please exclusively refer to what indicated in the sale agreement and in the warranty certificate in which all warranty conditions applicable to the purchased product are specified.

 **CAUTION**

The maintenance operations described in the manual are simple, but should be performed by authorised and qualified technical staff only, according to the standard procedures delivered by the devices Manufacturers and in compliance with national and international regulations. We suggest contacting the RIVA After Sales & Service Department.

 **CAUTION**

RIVA declines all responsibility for damage due to improper preservation and poor maintenance.

 **CAUTION**

RIVA declines all responsibility for the installation and operation of electric, electronic or mechanical equipment improperly installed by third parties in any unauthorised way by the Shipyard.

 **WARNING**

RIVA declines all responsibility concerning tampering carried out by third parties on equipment installed in the Shipyard. Such tampering or unauthorized installations will not only void the warranty, but may cause damage to the yacht and injuries to the people on board.

 **WARNING**

Equipment and devices: engine, winch, extractors and other devices are guaranteed by their manufacturers, who will service them directly through their service points. In case of need, the RIVA After Sales & Service Department will support your requests in order to provide you with a quick service and to guarantee the respect of the applicable rules. Upon yacht purchase, the Owner must send the Warranty Certificates of the relevant Manufacturers, in order to start the warranty period. RIVA will not be liable for undelivered Warranty Certificates.

1.3 KNOW YOUR RESPONSIBILITY AS OWNER

As owners of a yacht, it is your responsibility to be aware of several laws and rules applicable to navigation, operation and equipment of your yacht.

Personal flotation devices and other safety equipment must be approved by the Coast Guard and / or other organizations dealing with rules relating to safety. If approved, an adhesive will indicate on equipment itself.

Member States may impose additional requirements.

It is necessary that you know the rules that relate to your areas of action.

It is the responsibility of the owner and / or operator of the yacht to know the rules of navigation and safety and navigational practices.

Take up time to read the Nautical Rules of Navigation (COLREGS) that are found in the publication of the Coast Guard "Navigation Rules - International and Internal". Study the techniques of navigation and safety practices to run your yacht and its equipment.

You are the key person in ensuring the safety of your passengers, the crew and the yacht. Take up time to read the chapter on SAFETY in this manual for important information regarding the safety procedures.

Each yacht owner or operator must be well informed about the yacht and its systems.

Since you are responsible for the operation of your yacht, we provide you with information about these topics.

For every system on board we have planned a detailed description, including diagrams where appropriate, as well as information about the Maintenance and troubleshooting.

A variety of instruction manuals, courses and videos to help you to improve your knowledge of navigation rules, navigation, operation of the yacht, naval electronics operation, Maintenance, etc..

1.4 NOTICES

To highlight particularly significant sections and/or to indicate some important requirements, some symbols have been defined as follows.



CAUTION

It indicates a reminder to apply certain safety measures or to avoid certain unsafe practices that could lead to personal injury or damage to the yacht, to its components or to the environment.



WARNING

It indicates the existence of a possible hazard that may lead to personal injury or death, if proper safety precautions are not taken.



DANGER

It indicates the existence of a serious hazard that could involve a high probability of death or of serious injury if suitable safety precautions are not taken.



ENVIRONMENT

This symbol draws your attention to the possible hazards of environmental pollution.

NOTE

Draws your attention on information and important memos.

MAINTENANCE

This symbol indicates the maintenance schedules on the various on board devices.

1.5 SPECIFIC SAFETY WARNINGS

They integrate the general safety notice and are aimed at providing specific information about the nature of possible dangers.

Fire hazard:

To indicate a specific fire hazard.



DANGER
The cause of fire breaking is described here.

Electric shock hazard:

To indicate a specific electrocution risk.



DANGER
The cause of electrocution is described here.

Burn hazard:

To indicate a specific burn hazard.



DANGER
The cause of burn is described here.

Forbidden areas:

To forbid the access, the transit or the stay in a dangerous area.



DANGER
This area describes the forbidden area: for forbidden areas are meant dangerous places or the approaching to mechanical moving parts.

1.6 CERTIFICATION, CLASSIFICATION AND IDENTIFICATION

RIVA yachts undergo rigid and accurate tests required by the International Authorities in charge, in order to obtain a CLASSIFICATION CERTIFICATE.

The RIVA RIVAMARE CENTO yacht, on which you are about to cruise, has obtained the RINA S.p.A. (REGISTRO ITALIANO NAVALE) classification after supervision of the hull lamination, of the reinforcement structures, of the power system and of the safety equipment on board.



CAUTION

Always keep the plates readable and, if deteriorated or altered, address to RIVA After Sales & Service Department for replacement.

NOTE

Builder's plate: Part of the information is provided on the manufacturer's plate affixed to the yacht. A full explanation of this information is provided in the relevant sections of this manual.

The significant wave height is the average height of the waves that make up the highest third of the same, which is approximately wave height estimated by an experienced observer. Some waves know no twice this height.

In the figure aside you will find two plates shown in detail: Manufacturer plate and yacht identification code plate.

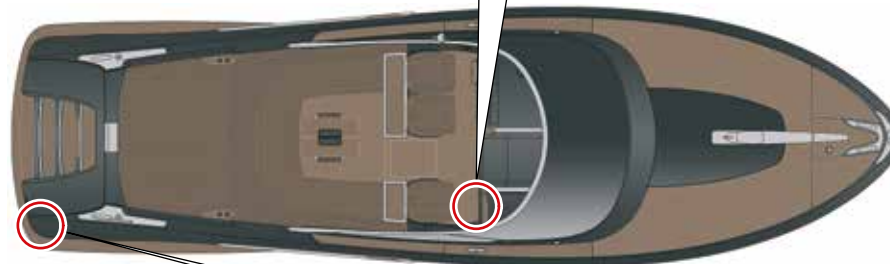
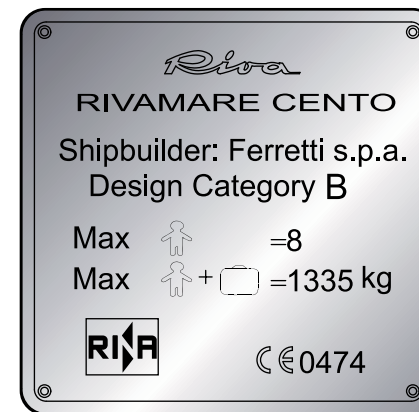



1.6.1 Yacht identification specifications

Manufacturer	FERRETTI S.p.A.
Model	R38 RIVAMARE CENTO
Type of yacht	MOTOR YACHT
Identification number CIN (Craft Identification Number)	IT-FERRRMH8C626
Design category	B (navigation in the open sea: wind force can be equal to or less than 8 and the height of the waves up to 4 metres)
Certification modules	B+F
Classification	“CE” conformity in accordance with the standards set out by Directive 2013/53/EU

1.7 LOAD-CARRYING CAPACITY

Maximum number of persons on board	no. 8 (RINA classification)
Maximum load recommended by the Manufacturer	1335 kg (2943 lb) (persons + luggage)
Safety equipment (standard)	no. 8
Berths	no. 2
Located in:	no. 2 in the Owner's cabin (double bed)

 **CAUTION**
 The maximum load carrying-capacity includes the weight of all persons on board, all their luggage and personal effects and any other equipment not included in the unladen displacement.

 **CAUTION**
 When the yacht is being loaded, never exceed the maximum load carrying capacity.
 Always take great care when loading the yacht and try to distribute the loads evenly so as to keep the correct trim.
 Avoid placing heavy loads in the upper part to not reduce the stability.

 **CAUTION**
 The maximum load recommended by the manufacturer excludes the mass of the contents of the fixed fuel and water tanks when full.
 It must exceed the total load that can be added to the displacement to download and dry yacht.

 **CAUTION**
 The standard safety equipment furnished by the Shipyard is for the maximum amount of passengers.
 Always check that the quantity of the above-mentioned safety equipment is at least equal to the number of boarded passengers.

 **WARNING**
 Do not exceed the maximum recommended number of persons. Regardless of the number of person on board, the total weight of persons and equipment must never exceed the maximum recommended load. Always use the seats/seating spaces provided.

 **CAUTION**
 Make sure that safety equipment is perfectly efficient and available to each passenger.



CAUTION

Changes in the arrangement of the on-board masses, such as the addition of weights at the top, a structure, or the replacement of components with different specifications, can significantly affect the stability, trim, and performance of the yacht.

In such cases, contact RIVA After Sales & Service Department.

Riva

RIVAMARE CENTO

SAFETY

CHAPTER 2

2.1 SAFETY RULES AND WARNINGS

Your yacht has been designed paying the utmost attention to all aspects regarding your safety and the safety of your guests. However, all personnel on board must be instructed and aware about some precautions to be adopted at all times.

For this purpose, it is advisable that all people on board carefully read the guidelines contained in this manual, as well as the signs installed on the yacht and, in particular, all safety notices.

The time spent in reading such instructions will prevent unpleasant accidents; it is always too late to remember what was supposed to be done, after the fact. Remember that you are responsible for your safety and the safety of your passengers, and that you may jeopardize the safety of other boats.

Please make sure you are perfectly aware of the main safety rules:

- During normal operation or any activities on the yacht, keep passage-ways and escape routes in proper conditions, in order to avoid hazards to people's safety;
- Always perform regular inspections of hull conditions, power system, safety equipment, and systems on a regular basis;
- Always check the fuel level before cruising and compare the tanks' capacity with the engines' consumption and the length and the expected type of cruise;
- Check the expected weather conditions in your cruising area;
- In any case, always act according to common sense.

Safety is also "in the hands" of all those on board, who should be instructed and aware of some precautions to be adopted all times:

- Move carefully around the yacht because its stability may be suddenly affected by the sea waves;
- Persons on board must know the location of life jackets and the location of fire extinguishers (see safety equipment) and of the life raft;
- All passengers must be aware of the risks caused by the fires and the correct way to proceed in the event a fire should occur;
- Everybody on board must be able to release and launch the life buoy and the life raft at sea;
- The engine compartment must be properly ventilated when the engines are running or during cooling; the air vents must therefore always be open and free of obstruction.
- Access to the engine compartment must be allowed only to authorized personnel, aware of possible dangers like:
 - Moving mechanical parts;
 - Hot parts and components;
 - Circuits with pressurized, hot or irritating fluids;
 - Circuits with flammable fluids;
 - High noise when engines are running;
 - Possibility to shift important valves for navigation safety unintentionally.

Do not tamper with, disconnect, eliminate or by-pass the safety devices installed on your yacht. Periodically check their real efficiency in time to ensure that they can be used in case of need. Failure to meet such requirements may lead to serious risks to the health and safety of passengers.

**CAUTION**

Personnel performing any type of intervention must be properly qualified and follow the instructions of the equipment manufacturer. Failure to comply with these requirements may cause damage to your yacht and/or injury to people.

**DANGER**

When the yacht is being loaded, never exceed the maximum load carrying capacity. Always take great care when loading the yacht and try to distribute the loads evenly so as to keep the correct trim. Avoid placing heavy loads in the upper part.

**CAUTION**

Always place the necessary attention while navigating, especially in adverse weather conditions or breaking waves.

**DANGER****Carbon monoxide poisoning**

Adequate ventilation of the yacht is required when the engines are running when navigating at low speeds or in conditions where fumes may re-enter the hull.

**DANGER**

The personnel in charge of the yacht must not be under the influence of alcohol, drugs or narcotics.

**DANGER**

It is absolutely forbidden to remain on the external decks outside protected areas during navigation.

2.1.1 Use-related rules

Your yacht has been realised with the utmost care by RIVA to grant the best possible reliability and safety to the persons on board.

It is anyway necessary to remember that these conditions, even if necessary, are nevertheless not sufficient, as reliability and safety are based upon strict and continuous observance, by the Owner and his/her Guests, of the so-called "On-board Ethics".

"On-board Ethics" means all those behaviour rules which all persons on board must strictly observe in order not to jeopardize the product that the Builder realised with so much care and professionalism.

Naturally, behaviour rules to be observed on board differ depending on the activity to be carried out.

Distribute loads so as to maintain the correct trim, do not overload the yacht, especially at bow and stern.

Observe the rules to prevent a sea collision and the speed limits, moreover pay always the highest attention during navigation.

The Captain, after having duly collected information on the yacht's operation and controls, should at first try and simulate some test manoeuvres with the aid of the Shipyard personnel, to familiarize with the controls and be aware of the typical reactions of this yacht.



DANGER

The responsibility for the operation of each boat lies solely with the captain.

It is the captain's direct responsibility to ensure, prior to departure, that the safety equipment required by law is present on board and fully functional.

The main operational steps, such as getting underway, navigation, anchoring and mooring must be carried out and verified scrupulously. In particular, all pre-departure procedures must be strictly followed.

All refuelling phases must be carried out taking all the precautions necessary to guarantee safety and to prevent even the smallest spillage of products which could pollute the surrounding environment.

When navigating near harbours, beaches and docks, observe the directives issued by local port authorities, particularly as to the speed; high speed can originate waves which can jeopardize the safety of the environment and of people.

Before lowering the anchor in free waters, check it it is allowed and verify the type of sea bottom, to prevent damaging or upsetting the surrounding marine habitat balance.

When entering and exiting, make sure that steps, handles and shoe soles are clean and dry.

In order to prevent the risk of injury, the instruments in the helm position must only be used from the correct piloting position.

**DANGER**

Do not use the yacht if the safety equipment is inoperative. Failure to meet this requirement may originate serious risks for the safety of your yacht and of your passengers.

**CAUTION**

Any changes in the disposition of the masses on board, such as the addition of weights on top, a structure or the replacement of components with different specifications, can significantly affect the stability, trim and performance of the yacht. In these cases, contact RIVA After Sales & Service Department.

**CAUTION**

Close portholes, windows and skylights while navigation, especially in poor weather conditions. Also, make sure that you have closed or locked doors to prevent collisions with objects or people.

**DANGER**

Do not remove or alter the protections of moving parts, adopted by the manufacturers of the utilities on board and by the shipyard, when using the yacht.

**CAUTION**

Avoid sudden manoeuvres at high speed.

**CAUTION**

For greater safety and comfort, reduce speed in the presence of waves.

2.1.2 Maintenance rules

In this section important information is given to enable you to operate the various components of the yacht without any hazard.

Periodical maintenance, including daily inspections, are important to keep the equipment/components in the best possible efficiency conditions.

Failure to comply with the maintenance plan may lead to unforeseen problems that can reduce safety at sea.

Read and understand all the information contained in the various technical manuals provided before undertaking any action or operating any systems. If you are not sure of aspect of the work to be done, please contact RIVA After Sales & Service Department or that of the device manufacturer.



DANGER

Always operate with caution, care and under safety conditions.



ENVIRONMENT

Any maintenance operation must be carried out in the strict respect of the surrounding environment. Take all necessary measures to avoid that even one single “oil drop” may be spilled: the protection of our environment starts with this type of attention.

NOTE

Before carrying out maintenance and adjustment operations on your yacht, activate all safety devices provided and evaluate if it is necessary to inform all persons on board.

In particular, according to the regulations in force, place warning signs in the areas that can be affected by the activity and prevent accessibility to any device or equipment that, if enabled, could cause hazardous conditions endangering persons on board and/or property.

Maintenance and adjustment operations must be carried out by qualified, authorized personnel that shall provide for all necessary protections according to the regulations in force.

NOTE

Persons performing maintenance operations in barely accessible or dangerous areas must provide for their own safety and that of any other persons involved, in compliance with existing workplace safety regulations. If necessary, wear individual protection means required by the task to be performed.

During navigation, access to the engine compartment must be limited to authorized and properly equipped personnel only.

Inspect the sea water system inlets and outlets as well as the bilge systems. These checks are vital to ensure the yacht buoyancy.

Do not perform any maintenance operations or adjustments other than those indicated and/or suggested by the Manufacturer. If necessary, contact RIVA After Sales & Service Department for more precise instructions.

NOTE

Keep all parts of the yacht clean using the methods and specific products indicated by the manufacturer.

Use only oils and greases recommended by the manufacturer.

Use only original spare parts to replace worn parts.

Before maintenance or commissioning of the yacht or any component part, carefully read the instructions for use.

**DANGER**

The use of faulty lifting attachments can be the cause of accidents; check therefore their efficiency. Ensure the compliance of hoisting gears with local norms and their suitability for the job to be performed.

The use of unsuitable clothing can cause accidents; do not wear flapping clothes that could be easily caught by the moving parts of the yacht. Wear protective clothes suitable with the kind of work to carry out.

Keep OFF from taking alcohol or drugs before and during the work.

Insufficient information may cause accidents. If two or more persons are working simultaneously on the same machine, make sure that each of them is aware of the operation carried out by the others. Therefore, prepare a working plan so as to avoid any interference or hazard.

Before starting an engine, get other persons away from hazardous areas.

Failure to comply with these precautions may cause serious injury, and even death.

When performing maintenance operations inside the engine compartment, you must make sure that the engine cannot be started from the helm position by unauthorized persons.

**DANGER**

Keep the entire work area, in particular the area around the engine and stairs, free of oil and grease stains.

Injury due to slipping may have serious consequences.

Oil leakage at operating pressure can cause injury: before disconnecting or connecting the hoses, stop the engine and operate the controls to release the residual pressure. Prevent the engine start when the hoses are disconnected.

When the outer temperature falls below 4°C inside the ducts where water flows, there is the risk that the water freezes inside them and, thus, that breaks occur.

Incorrectly mounted and/or damaged and/ or worn gaskets and O-rings can cause damage; replace them immediately.

**DANGER**

The battery produces explosive fumes; do not approach with flames and sparks nor smoke in its vicinity. If the battery is used or charged in a closed area, make sure good ventilation is provided. Do not check the battery charge status by short-circuiting the terminals with metal tools (the battery may explode): use a hydrometer or voltmeter. The electrolyte contained in the batteries is extremely corrosive: while charging or handling of the batteries, we recommend protecting your skin, eyes and clothing. Always use safety glasses and gloves. If the electrolyte gets into contact with the skin, rinse as soon as possible by washing with water and soap. If eyes are involved, immediately rinse with plenty of water and then ask for medical assistance.

Move away from the working area or adequately protect possible flammable materials, which could catch fire from sparkles.

Possible sparks produced by the electric system may cause explosions and fires. Avoid starting the yacht in the presence of flammable materials, liquids, vapours or flammable powders.

Fuel is flammable and explosive: do not approach with flames, do not smoke while refuelling or while working on the engine. Carry out refuelling with engine shut OFF. Failure to comply with these precautions may cause fires with hazard of serious damage to property and injury to persons.

**DANGER**

Suspended loads may fall and injure you. Do not walk or work under lifted devices not sufficiently and safely supported.

Due to moving mechanical parts, when working on the shafting and on engines parts, absolutely prevent starting of the latter.

**DANGER**

Before performing tasks on the electric system, always cut OFF power supply on the whole system or on the component on which you are operating, in order to prevent risks of shocks or electrocutions.

If necessary, first disconnect the negative cable from the battery and then connect it last to prevent short circuits.

**DANGER**

Precautions to safeguard your health:

Oil, fuel and antifreeze are toxic substances: do not swallow.

These substances also contain dangerous contaminating agents which may cause damage to the skin.

Protect your eyes from accidental splashes of toxic substances by using safety goggles.

Store products and technical fluids for yacht operation (such as anti-freeze) only in containers that cannot be mistaken for beverage holders.

Due to long and repeated contact with engine oil of any type, the skin can degrease and dry out with consequent irritation or even inflammation.

**DANGER**

Avoid long and repeated contact of the skin with toxic substances.

Protect the skin with suitable protective products or with safety gloves.

Clean the skin by washing it thoroughly with water and soap. A valid help can come from special hand detergents and a brush. Do not use any fuel, thinners or solvents to clean the skin.

After cleaning, treat the skin with special greasy cream.

Change oil-soaked clothes and shoes.

**DANGER**

If an accident occurs despite all precautions, seek medical advice immediately.

**DANGER**

Coolants are hot. When engine temperature is high, the cooling system is under pressure and, by removing the heat exchanger plug, the hot liquid can come out as a jet!

Wait for the system to cool down, then very slowly rotate the cap and vent the system pressure.

Always cover the cap with a cloth when performing this operation.

NOTE

RIVA declines all responsibility for the installation and operation of electric, electronic or mechanical equipment improperly installed by third parties in a fashion not authorised by the Shipyard.

RIVA declines all responsibility concerning tampering carried out by third parties on equipment installed in the Shipyard. Such tampering or unauthorized installations will not only immediately void the warranty, but may cause damage to the yacht and injuries to the people on board.

RIVA declines all responsibility concerning periodical maintenance activities scheduled by the Shipyard or by Manufacturers, but not carried out, on equipment/components, for which it is necessary to refer to their own Technical Manuals.

2.1.3 Fire prevention rules

Before operating the yacht, the captain must be familiar with the following fire prevention regulations.

The yacht must always be equipped with portable extinguishers, located as shown in the diagram "Arrangement of safety equipment".



DANGER

On all yachts, fire is a major danger.
All fire prevention measures must be followed scrupulously.

It is the direct responsibility of the captain of the yacht to do the following:

- Having fire-extinguishers and fire-fighting systems overhauled by the date shown on the label of each single extinguisher and have them replaced, as required by the rules in force, with other extinguishers of equivalent or even higher capacity;
- Informing the crew about the location and use of fire extinguishers and fire-fighting systems and escape routes;
- Ensuring that fire extinguishers are also available.



DANGER

Never:

- Obstruct passageways and the escape routes;
- Hinder access to safety devices, such as fuel valves, electrical switches, etc.;
- Obstruct access to fire extinguishers;
- Leave the yacht unattended, when burners or heat generating equipment are ON;
- Use naked flames;
- Modify electric or fuel supply systems, without consulting RIVA beforehand;
- Smoke near or when handling flammable materials;
- Do not stow highly flammable materials near heat sources;
- Stow flammable material in the engine compartment. Non-flammable materials may be stowed only if properly rigged, so they do not accidentally come into contact with rotating engine parts, or obstruct access to the engine compartment.

Keep the bilges dirty and fail to inspect them frequently for possible oil or fuel leakage.

NOTE

Carefully read the prescriptions regarding the fire-extinguishing system and its use.

**DANGER**

In case fire breaks out in proximity to electrical equipment, do not use water, use the manual dry-powder fire extinguishers only. After using the extinguishers, leave and ventilate the area immediately before re-approaching it, in order to prevent asphyxia and physical harm.
Clean out any fire extinguishing powder out very carefully.

**DANGER**

In case of fire on board, try to electrically insulate the area concerned by disconnecting all AC and DC input magneto-thermal switches to avoid feeding fires and short circuits.

**DANGER**

In case of the risk of the yacht sinking, close the fuel and black waters valves.

In addition to these requirements, RIVA recommends the following:

- Avoid smoking lower deck, especially in the engine compartment.
- Avoid pouring liquids into the bilge and keep it clean, especially around the engine compartment. If there is fuel leakage from the engines, proceed as follows:
 - Stop all engines immediately;
 - Locate the leak cause and, if possible, repair it after closure of supply valves;
 - Dry and clean the bilge before restarting the engines, without draining at sea or in the harbour;
 - Do not stow flammable items in proximity to heat sources, like engines, halogen lamps, etc..;
 - Should the yacht leak, try to remedy with plugs and/or rags, if possible, from outside;
 - In case a system of the yacht breaks, close all hull valves, locate and repair the leak if possible. Remember to reopen all hull valves not involved.

NOTE

The Captain of a pleasure yacht must be perfectly aware of the basic fire fighting techniques and how to use the extinguishers.

Regular and correct maintenance of the systems and prudent behaviour of all passengers are indispensable measures for preventing any risk of fire.

Over 90% of the probabilities of fighting a fire successfully, depends on the ability to prevent and avoid any condition that may favour a fire to spread. The small remaining percentage depends on the crew's reaction ability, and most of all, their rapidity to enter into action.

Nearly all fires, if detected early, can be extinguished easily.

For these reasons, it is necessary to carry out preventive surveys on a regular basis and identify all possible fire sources, and in particular:

- Check the proper operation of all main equipment/systems;
- Visit all compartments and in particular the engine compartment frequently;
- If a system does not work correctly, identify the failure and take the appropriate corrective actions;
- Operate all systems and equipment as specified.
- Not stow on-board flammable materials where not expected.

If a fire is detected, identify and remove the cause, if possible, (e.g. in case of a short-circuit, cut-off the electrical system), extinguish the fire promptly and be vigilant to make sure that the fire does not break out again.

Each yacht owner/operator/master must be well informed and proficient regarding the measures to be adopted in the event of a fire and the applicable fire-extinguishing methods.



CAUTION

The ability to operate the fire extinguishers properly can ensure the success of the operation. It is vital that the fire fighting operations are performed by people competent in this type of emergencies. It is in any case necessary to be aware of the minimum fire-prevention and fire-fighting rules; the first defence is to prevent fires before they start spreading.



WARNING

EXPLOSION HAZARD

Any lithium battery powered device on board must be recharged only in open air areas, connected to a suitable charging system. Also please refer to the device dedicated Use and Maintenance Manual.

The following table contains the classification of the fire types:

Comparison between fire classes

American	Europe/Australia/Asia	Fuel/Heat source
Class A	Class A	Ordinary fuels
Class B	Class B	Flammable liquids
	Class C	Flammable gases
Class C	Class E	Electric appliances
Class D	Class D	Combustible metals
Class K	Class F	Cooking oil or fat

It is very important to use the correct extinguishing agent according to each fire class; normally, water can be used only for class A fires, together with chemical extinguishing agents (portable or fixed devices).

2.2 NOTES ON THE ENVIRONMENT

Environmental pollution is caused by three kinds of polluting agents:

- Water polluters;
- Air polluters;
- Soil polluters.

Non oily and black waters (containing only human organic waste) can be discharged into the open sea. In the port area, these must be collected in special tanks and then unloaded either by removal at open sea or by means of appropriate fixed shoreside or truck-mounted emptying systems.

Soil pollution is also caused by discharging waste at shore.

International regulations regarding recreational craft essentially provide for the following:

- During navigation it is forbidden to discharge any non biodegradable product, either of food or commercial origin, into the open sea.
- In ports, normal waste is considered to be similar to urban waste and therefore can be enclosed in plastic bags and disposed of in designated waste bins.
- Special waste must be disposed of into suitable containers or, if these are not available, it must be delivered to local waste disposing areas, in compliance with the norms in force, issued by the local Port Authority.



ENVIRONMENT

During navigation, do not dispose any on-board waste at sea, but keep it and dump it on waste containers ashore.

Remember that it is forbidden to dump oils and fuels into the sea; therefore, it is recommended to clean the engines' bilges by using absorbent materials to be disposed of later on into dedicated containers.

- The following waste is considered special waste:
 - Water and oily mixtures (e.g.: bilge water)
 - Oils (fuel, additives and lubricants)
 - Poisonous chemical substances (like battery acids, paints, thinners and the relevant containers)
 - Spray cans containing C.F.C. gas
 - Batteries
 - Spent flares
 - Expired pharmaceutical products
 - Products containing lead or asbestos
 - Etc..
- Fuel and oil leaks
- Waste discharge and disposal
- Excessive noise
- Wake / wake from board
- Exhaust fumes
- Paints, detergents and other agents

Please remember that, according to legislation, until such waste is delivered to suitable disposal areas, you will be considered as possessors and therefore indictable in case of unlawful discharge.

Should specific cases be missing in the harbour area, the Authority in charge for the disposal is the Port Authority section "Waste Disposal".



CAUTION

During navigation, it is always necessary to behave suitably and to respect the safety and the comfort of your guests and of persons on nearby yachts. Therefore:

- Avoid excessive noise;
- Do not leave the engines running for long periods without moving off;
- Do not cruise at high speed or beyond the permitted limits when leaving or entering harbours, marinas, etc., to prevent causing excessive wash or wave motion.

2.2.1 Regulations for waste disposal

The rules governing the discharge of waste (MARPOL 73/78) apply to all boats with no limits on tonnage and service, including recreational craft. The regulations apply to the entire Mediterranean Sea.

When moored in a harbour, always check that your yacht is not a source of pollution. The environment must be respected and safeguarded, preventing risks for the life of aquatic flora and fauna.

It is good practice to leave no trace behind you, to respect laws on safety and environmental protection. Do not discharge bilge waste, oily residues, fuel or other liquids overboard. Solid waste and used engine oils should be deposited in the containers provided near the berths.



ENVIRONMENT

It is absolutely prohibited to throw plastics, synthetic cables, fishing nets, waste bags, floating packaging materials, paper, rags, metals, bottles, galley utensils and similar waste into the sea. Non comminuted or un-ground food waste can only be disposed of beyond 12 miles.



ENVIRONMENT

Always consider and comply local and international laws against marine pollution (MARPOL).
It is always necessary to respect the rules of good yacht conduct.

Although discharge at sea, except in special areas, of a wide range of ship-generated garbage is permitted at specified distances from the nearest land, preference should be given to disposal at shore reception facilities.

2.3 SAFETY EQUIPMENT

RIVA has equipped your yacht with specific equipment to ensure guarantee the highest possible degree of safety even in the most dangerous situations. All persons on board must know the location and use of the safety equipment.



CAUTION

The diagram shows the position indicated by the manufacturer for safety equipment; therefore represents a useful guide the placement and number. To adapt and place the safety equipment in accordance with local, national, and international laws.



CAUTION

Please note that the above mentioned safety systems must comply with local and international navigation laws.



CAUTION

The Captain is required to inform the crew on the yacht about the safety equipment, whether in case of fire or in case of sinking and listing.



CAUTION

Make sure that safety equipment is perfectly efficient and available to each passenger.





DANGER

Periodically inspect the wear conditions of safety equipment and check servicing or replacement dates, so that the equipment is always in perfect working order.

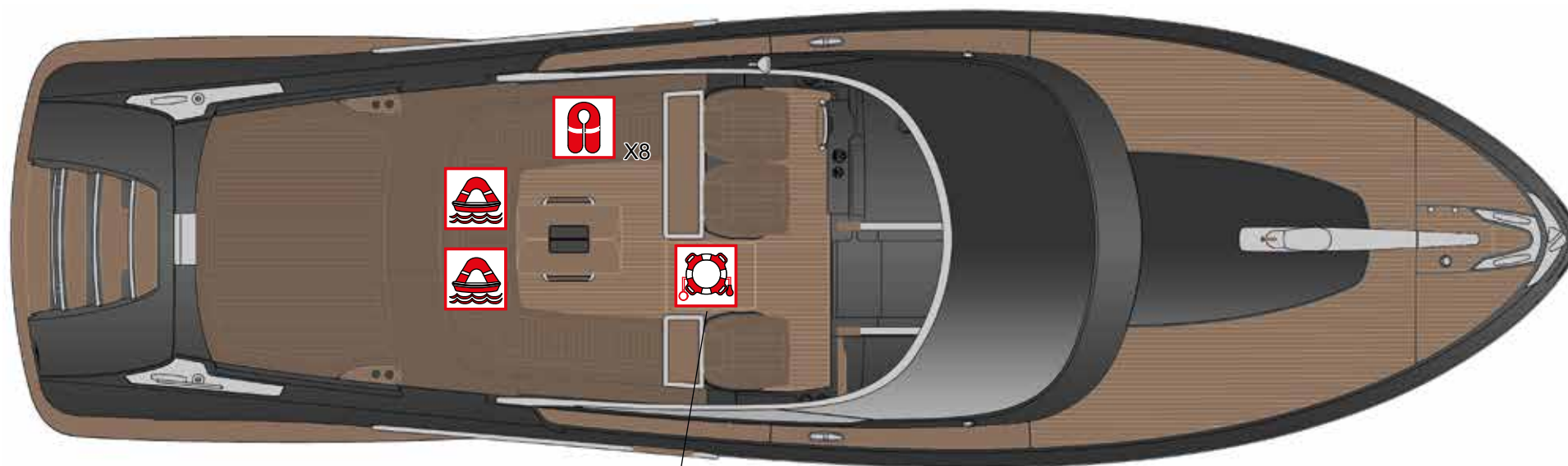
2.3.1 Arrangement of safety equipment



Sottocoperta
Below the deck

ICONA ICON	DESCRIZIONE DESCRIPTION
	Zattera autogonfiabile di salvataggio Self-inflatable life raft
	Salvagente anulare Life buoy

ICONA ICON	DESCRIZIONE DESCRIPTION
	Salvagente a giubbino individuale Individual life jacket

2.3.2 Arrangement of fire prevention equipment

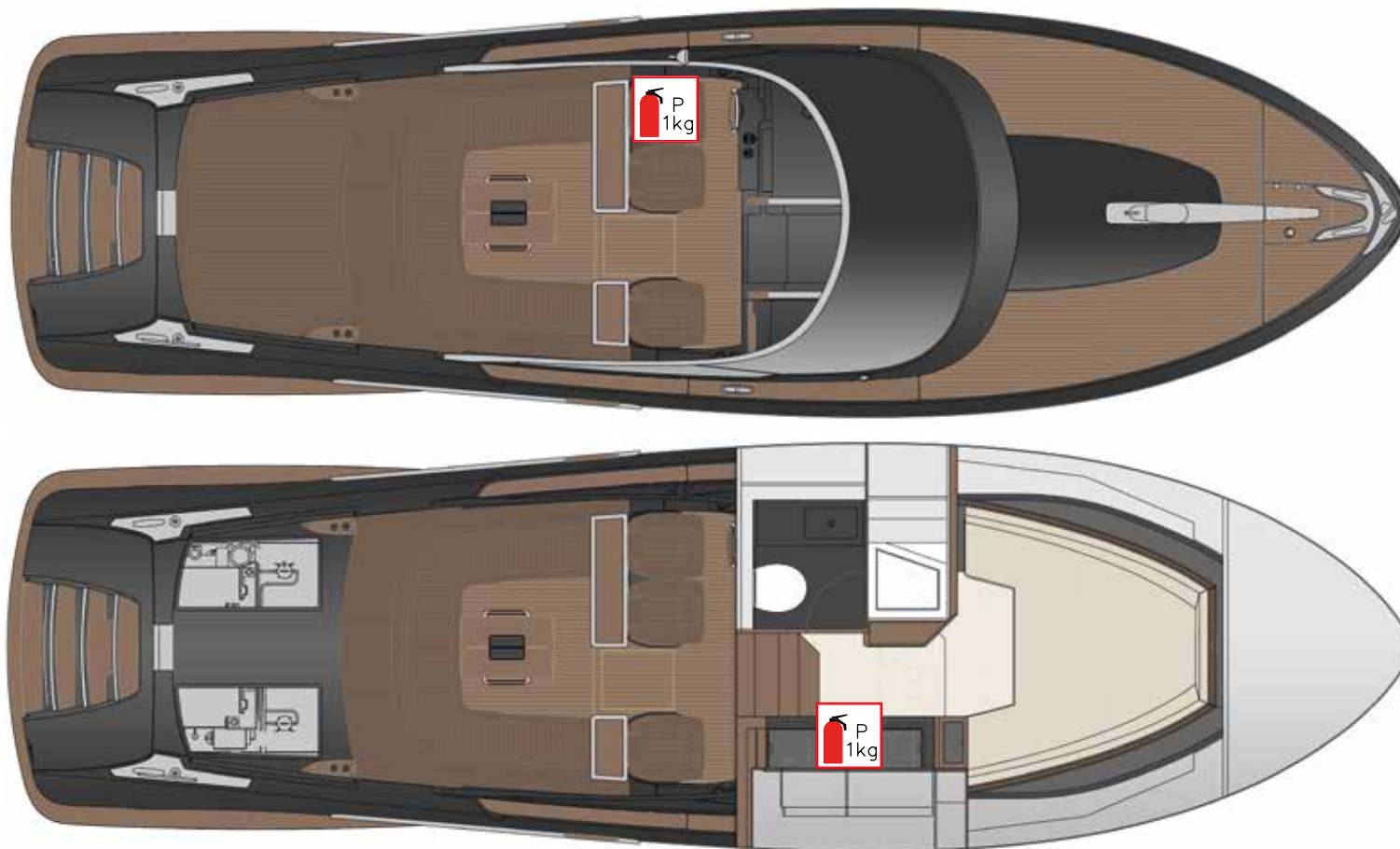

ICONA ICON	DESCRIZIONE DESCRIPTION
	Estintore portatile a polvere Portable dry-chemical extinguisher

2.3.3 Self-inflatable life raft

Self-inflatable life raft must be used only in case of real emergencies, requiring the abandonment of the yacht.

The yacht must in fact be abandoned in case of a serious sinking hazard, or in case of fire becoming out of control.

In all other cases careful evaluation is necessary, because to leave the own yacht, even though on a self-inflatable life raft, could mean a more difficult identification the rescue team.

As a matter of fact, the search for the shipwrecked will start exactly from the last known position of the yacht.

NOTE

The validity of self-inflatable life raft is limited: check its expiry date on the certificate provided by the Manufacturer.

NOTE

Self-inflatable life raft can be overhauled at authorized Centres that shall extend the validity of the certificate. Sanctions are provided if this rule is not respected.



WARNING

Before any trip, check that there are no impediments to its immediate use.



In case the use of self-inflatable life raft becomes necessary, perform the following operations:

- Shut the engines down and put on the life jackets;
- Perform the distress call using the VHF device;
- Wear life jackets.
- Remove the cushions (seat and backrest) of the cockpit's port side sofa, and open the hatch.
- Unwind the line for 3 or 4 metres; secure it firmly to a fixed point of the yacht and throw the self-inflating life raft into the sea from the leeward side;



WARNING

Check that the anchoring line is always well fastened to the yacht.

- Unwind the lifeline completely, then give a strong and decisive pull; the raft will open in a couple of minutes;
- Board by jumping directly from the yacht into the life raft;
- If you launch the distress call and receive an answer, prepare for a relatively short wait; assess whether or not to cut the restraint line. If you have not had the opportunity to make a distress call or have not been answered, prepare for a long wait; in this case, plan for survival, taking the following items, as well as the equipment included in the kit: floating smoke signals and rockets, a knife, drinking water and energy foods that do not cause thirst. Before boarding the raft wear all possible garments, except for shoes that could injure other shipwrecked persons or damage the life raft;
- Take on board any clothes and food supplies;
- If somebody falls overboard, help him/her to up into the life raft; throw the life buoy with line, if necessary;
- Make sure that all the personnel is on board and assess if it is better to cut the connecting line or not.

- Extract the knife supplied with the raft from its sheath and use it to cut the connecting line that secures the self-inflating raft to the yacht.
- Move quickly away from the sinking yacht, using the oars;
- When the overpressure valves have stopped hissing, close them by tightening the safety plugs.



DANGER

If the life raft opens upside down, jump into the water and roll it over, by pulling the special rope.

If the life raft does not open after the first pull, repeat the operation two or three times. If the life raft still does not open, jump into the water and, keeping a hand on the container, pull the emergency line strongly. If the life raft still does not open, cut the container open with a knife and operate the opening device directly (by pulling the life line).

The oars with which it is equipped are only suitable for minor manoeuvres.

- The life raft is fitted with stabilisers and a floating anchor, for improving its stability and drift. The stabilisers give stability to the raft. Keep the floating anchor into the water. The anchor prevents excessively rapid drifts.
- When the life raft is towed, weigh the floating anchor on board.
- If the sea is rough, it is advisable to wear the life jackets all the time.
- If the raft deflates, inflate it again from time to time using the relevant inflating device provided with the raft.
- If air blows out of a hole, use one of the plugs stowed inside the repair kit.
- You can perform minor repairs, by using the glue provided with the kit. Clean the torn area and the repair pad, spread both with the glue. Hold the pad for thirty seconds, pressing from the centre outwards, in order to eliminate any air bubbles.
- Hold down for a little time and inflate again, after one hour.



DANGER

All persons on board must know the position in which the self-inflating life raft is stored and the correct procedures for use.



DANGER

With very high waves and strong wind there is the risk that the raft may overturn: shift the weight of persons on board towards the side tending to lift.
If the life raft all does capsize, roll it over and return on board.

2.3.4 Individual life jacket

The life jacket is an individual safety device, consisting of a single chamber inflatable jacket, yellow-coloured to be easily visible in water and resistant to the effects of sea water, hydrocarbons and low temperatures.

This type of life jacket preserves the safety and floatability requirements required by EU regulations.

These life jackets must be worn correctly and firmly tied by means of strong laces.

The individual life jacket is contained in a belt bag container.

The individual life jacket is equipped with an orange whistle, fastened to the jacket by means of a safety cord.

The whistle is particularly useful to indicate the wearer's position when the weather conditions do not allow sufficient visibility (bad weather, fog, etc..).

To avoid energy waste it is necessary to float by keeping legs and arms folded as far as possible and tight to the body to maintain the heat.

The individual life jacket has to be worn under following circumstances:

- When you navigate through sandbanks or tide reefs;
- At first sign of bad weather;
- When visibility is limited;
- When you navigate with rough sea;
- When you navigate alone;
- At any time with children beyond 10 years of age.



**CAUTION**

The yacht must be equipped with a number of individual life jackets equal to the number of persons present on board. All persons boarded must know the location of the life jackets, how to wear them, how to tie them properly to the body, and where the whistle is located.

**DANGER**

If you are to choose a life jacket for a child, take care about for the correct size and that smaller children do not slip out of them once in water. We recommend that all children wear an individual life jacket when they move on the yacht.

**CAUTION****CARING FOR AND INSPECTING THE LIFE JACKETS**

The life jackets must be handled with care so that they are able to save your lives whenever necessary.

Check that all the belts, braces and buckles are in good condition and firmly secured on a regular basis. Make sure that all the seams are steadfast and that any welded or glued part adheres perfectly. Check that the reflecting strip, whistle and light are firmly secured and that the light battery has not yet expired.

MAINTENANCE

Wash in warm soapy water after use.

Dry thoroughly.

Store in a dry, ventilated area away from direct sunlight and harmful chemicals.

Check the lifejacket regularly to make sure it is in good working condition.

**CAUTION**

Do not use the life jackets as pillows.

Practice of their use before you start navigating.

For people with problems may not be suitable.

With waterproof clothing or similar you can not reach the optimal use.

The use of lifejackets does not guarantee total safety and the final rescue of the wearer, but it does support in water for a long period.

2.3.5 Life buoy

The life buoy is equipped with a lifeline of 30 m and with an automatic light buoy.

The life line is not twistable and it is orange in order to be easily seen in water.

At least once a month:

- Check the fastening of the floating line;
- Check the loading condition of the batteries of light buoy;
- At least once every 6 months check the status of the floating line.



CAUTION

All crew and passengers must know the location of the life buoy.



CAUTION

The captain must ensure that the crew and passengers are familiar with the use of the life buoy:

- How and where to throw it;
- How to behave in case of “man overboard”.



2.3.6 First aid kit

The first aid box must be kept on board of class A crafts qualified for navigation“ with no limits from the coast”.

The container must be rigid, floating and with watertight closure.



ENVIRONMENT

It is forbidden to discard medicines at sea, even if expired. Treat medicines as special waste and therefore in accordance with the disposal procedures envisaged by the Country in which you are staying/ transiting.



DANGER

Remember to check the expiry date and **availability** of the products contained in the first aid box at regular intervals.

Remember to store those medicines, which need to be kept in cool places in the fridge.

Inform all passengers of this.

Keep the first aid box in a place free from moisture and away from heat sources, easily accessible, quickly reachable in case of need and far from the reach of children.

2.3.7 Signalling rockets

Pleasure yacht are obligated to carry 4 manual rockets with red light and 4 manual orange smoke signals as required.

Always verify the legislation of the Country in whose waters the yacht is going to navigate.

- The signalling rockets have a limited lifetime; it is also necessary to check their expiry date and eventually to replace them.
- The floating smoke signals, visible up to 4 km, have to be used with the daylight, to indicate the correct position.
- The red light rockets, visible up to 10 km, are designed for night use, but they can also be seen during the day.
- Before using the signalling rockets, always wait for the arrival of an air plane or to see persons on the shore or on other crafts.
- Store the signalling rockets far from flammable liquids and from other fuels.
- As the content of the signalling rockets absorbs the moisture, make sure to have them located in a dry and accessible place.
- All persons boarded must know the place of the signalling rockets and the method of use.
- Carefully follow the activation instruction for all signalling rockets.
- Each month, and anyway before each navigation, check that they can be used immediately without obstacles.



DANGER

Keep the signalling rockets far from heat sources, such as flammable liquids or naked flames, and out of the reach of children.



DANGER

Once the signalling rocket has been lit, never direct it towards persons, there is a risk of burns and scalds.



WARNING

The signalling rockets have a limited lifetime, indicated on their containers. Once expired, contact the rockets suppliers which offer a disposal service. Do not light them unless necessary, because they can activate the Emergency Services.

2.3.8 Emergency boarding system

Recover a man overboard before possible hypothermia or drowning. The time of permanence afloat depends on critical conditions of the water, on swimming capacity, on the presence of bulky clothing, intoxication, possibly injury and debilitation.

Recovering a man overboard depends on the capacity of manoeuvring the yacht (knowledge of the yacht's speed and turning capacity) and on the experience concerning rescue procedures.

Rescue is a combination of actions: reach the man overboard, establish a contact and bring him/her on board.

- Keep a visual contact with the man overboard.
- Slow down and go towards the man overboard. At night, direct the best light source available towards the man overboard.
- Launch the life buoy into the sea, towards the man overboard, and fasten it to the yacht by means of a line. It shall be used as a further reference to the rescuers.
- When approaching the man overboard, stop the yacht or slow down.
- When you are near the man overboard, stop the engines with the gear engaged, in order to avoid that the propellers continue rotating.

Help the man overboard board the yacht. The person shall generally board the yacht from the stern, through the boarding system (1). If the man overboard is injured, an expert rescuer may wear some floating rescue equipment tied with a line and enter the water to give assistance.

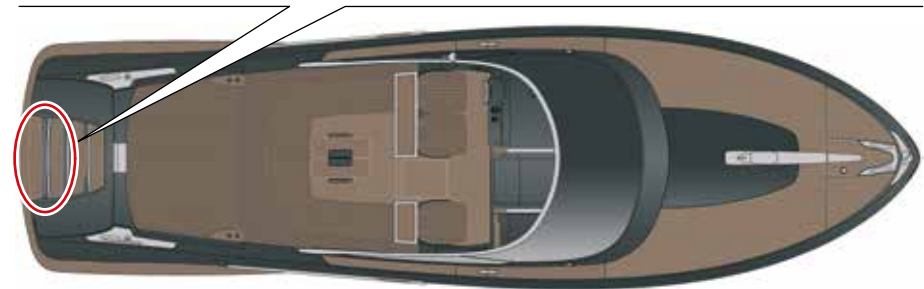

NOTE

If the victim presents drowning symptoms, give specific assistance. In case of serious danger, immediately make a distress call.



WARNING

In case of fall in the water, to go up on the yacht, use the special handrails (1) positioned aft.

2.3.9 Portable fire extinguishers

Portable fire extinguishers are provided on board the yacht; these are designed to be transported and used by hand and comply with applicable regulations.

The fire extinguishers have been placed in visible and easily accessible positions, and the position is indicated by special plates applied by RIVA.

The use of a fire extinguisher requires a certain familiarity with it, but some theoretical-practical rules can facilitate its handling:

- Make sure that the safety pin (1) against accidental discharge, has been removed;
- Always direct the extinguisher towards the bottom of the flame;
- Do not stand but try to bow as far as possible;
- Do not hit the fire from above;
- Shift the fan-shaped jet slowly from one side to the other of the flame;
- Act immediately before the temperature becomes too high;
- Always stay windward;
- If the material burnt is wood, paper or tissue, after the fire has been extinguished, pour on water to prevent any further spread of flames;
- Always act dressed, avoiding loose clothing or similar;
- Head the yacht so that the fire is leeward;
- Persons not engaged with the fire fighting must gather windward from the fire area and if necessary, disembark on a rescue device (tender, rubber dinghy, self-inflatable life raft), that must be linked to the yacht with a line, in order also to embark the persons engaged with the fire fighting;
- If the fire is big the operators must abundantly wet their clothing;
- The engines must be shut-OFF immediately and the fuel must be cut-OFF;
- Isolated objects in flames must immediately be thrown overboard;
- All openings that can allow air to penetrate through the flames must be closed;
- After using the extinguisher to fight fire in closed spaces, ventilate the space carefully, prior to entry, and remove powder deposits.

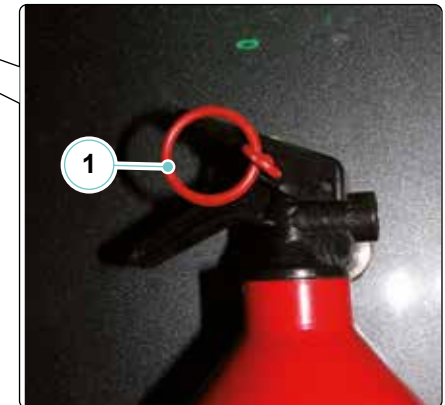

**DANGER**

The person in charge of the yacht must make sure that all passengers know the locations and how to operate the fire extinguishers on board correctly.

**CAUTION**

We advise regularly checking the charge status (visual check of pressure gauge and weight) and also its overhauling, according to the rules in force in the country whose flag the yacht flies.

**DANGER**

Pay particular attention during the cleaning and cooling operation because the components are still hot and can generate burns or scalds.

The arrangement of portable fire extinguishers is shown in the “Fire extinguisher location” diagram above.

**CAUTION**

All fire extinguishers should be checked at least every 12 months by qualified staff and in any case, after each navigation. Even after a partial use, the extinguishers should be recharged by authorized personnel.

The extinguisher should be kept in a good condition and the charge indicator, located on the pressure gauge, must always be positioned in the green field.

Keep the extinguishers in a vertical position.

After the use of a dry-chemical fire extinguisher, carefully clean the parts that came in contact with the powder because it is highly corrosive.

**WARNING**

For further information relevant to the use of the different systems and equipment, see the various manufacturers manuals, delivered separately.

Portable fire-extinguishers maintenance

Component	Maintenance	Notes and precautions
Portable fire extinguishers	Checks and tests	<p>Check the state of charge of each fire extinguisher at least once every 12 months, and in any case before each journey at sea, by means of the installed pressure gauge. The fire extinguisher is correctly charged when the weight value is as stated on the fire extinguisher's tag, and the charge indicator on the pressure gauge is in the green area.</p> <p>If they are found to be discharged or insufficiently charged, or at least every 10 years, have qualified technicians:</p> <ul style="list-style-type: none"> • Check the condition of the container (cylinder); • Refill the extinguishing medium; • Carry out a hydrostatic test. <p>Have fire extinguishers recharged even after partial use.</p> <div style="border: 1px solid black; padding: 5px; margin-top: 10px;"> <p style="text-align: center;">MAINTENANCE</p> <p>At least every 12 months, and, in any case, before each journey to sea, check the state of charge of the fire extinguisher.</p> <p>At least every 10 years, and in any case before each journey to sea, check the external state of the fire extinguisher.</p> <p>At least every 6 months check the fastening of the fire extinguisher.</p> </div>

2.4 MAN OVERBOARD RECOVERY

Recover a man overboard before possible hypothermia or drowning. Rescue is a combination of actions: reach the man overboard, establish a contact and bring him/her on board.

- Keep a visual contact with the man overboard.
- Slow down and go towards the man overboard. At night, direct the best light source available towards the man overboard.
- Launch the life buoy into the sea, towards the man overboard, and fasten it to the yacht by means of a line. It shall be used as a further reference to the rescuers.
- When approaching the man overboard, stop the yacht or slow down.
- When you are near the man overboard, stop the engines with the gear engaged, in order to avoid that the propellers continue rotating.
- Help the man overboard board the yacht.

NOTE

If the victim presents drowning symptoms, give specific assistance.
In case of serious danger, immediately make a distress call.

2.5 ESCAPE ROUTES

In order to cope with the different emergency situations that could require the abandonment of the yacht (fire, collision with sinking hazard, etc..) in the quickest and safest way, the rules in force require an “escape plan” informing about the safest as well as quickest paths for taking shelter and reaching the “muster stations”, located outdoors, from which it will be easier to leave the yacht.



CAUTION

Always keep the escape routes, dry, free and accessible.



CAUTION

The stairs must be carefully used during navigation.



DANGER

The on-board personnel must ensure that escape routes and paths are always free and accessible.

NOTE

All people on board must be aware of the risks and dangers that they can meet when aboard the yacht.
In particular, they must know which are the safest escape routes under different emergency conditions.



DANGER

According to the nature and position of the danger or fire source, to choose very carefully the safest and most suitable escape route.



DANGER

For safety reasons, the engine compartment access doors must be kept closed at all times and in all situations.
They must only remain open when in use.

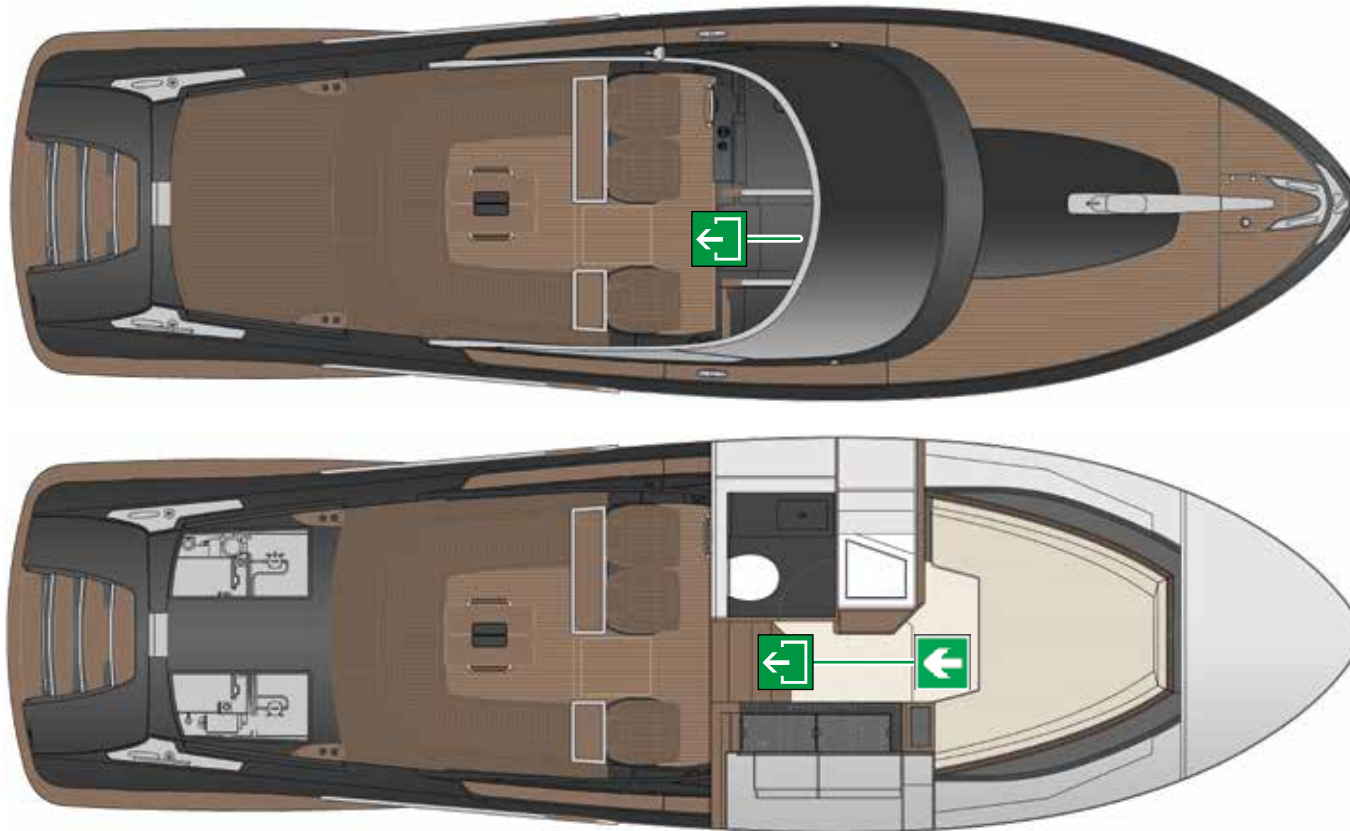

ICONA ICON	DESCRIZIONE DESCRIPTION
	Via di fuga Escape route
	Sfuggita Escape

2.5.1 Abandonment of the yacht

When you must abandon the yacht, swim against the current or windward.
The fuel leaks float in the direction of the current and can catch fire.
When you have taken shelter, count the person present on the yacht and help people in need.
Take advantage of the distress call.

Keep all people gathered in order to facilitate the rescue operation.

2.6 FORBIDDEN AREAS

On board the yacht some areas are “dangerous“, and need plenty of care, and possibly require wearing protective equipment, in order to safeguard the integrity of people on board.



DANGER

During navigation, the risks relating to any hazardous area increase significantly; we recommend scrupulously observing the safety rules indicated in this manual.

The areas are following:

- Engine room: area with a high level of noise, presence of moving components, hazard of burns, hazard of stumbling and falling. The access to the engine compartment is only allowed to trained and expert crew, prepared for the risks and equipped with proper safety devices, if necessary;
- Aft platform and bow area: outer area not protected by rails against falling into the sea. During navigation the access to this area is forbidden. Accessing and staying in this area is allowed only when the yacht is idle and with the engines shut OFF.

When underway, passengers can stay in the cockpit, preferably remaining seated. When moving, passengers shall use the special handrails installed in the cockpit.

In case of fall overboard, following rescue devices can be used:

- Life buoy;
- Individual life jacket;
- Emergency boarding system.

The following diagram marks out the dangerous areas, with different colours according to the risk level, where utmost care must be paid.



DANGER

Be careful when the deck is slippery.

NOTE



It is responsibility of the Captain to inform all persons on board about dangerous areas when they exist, possible areas temporarily forbidden when maintenance operations are being carried out, as well as about the correct behaviour to be adopted in the above-mentioned areas, also according to weather and sea conditions.

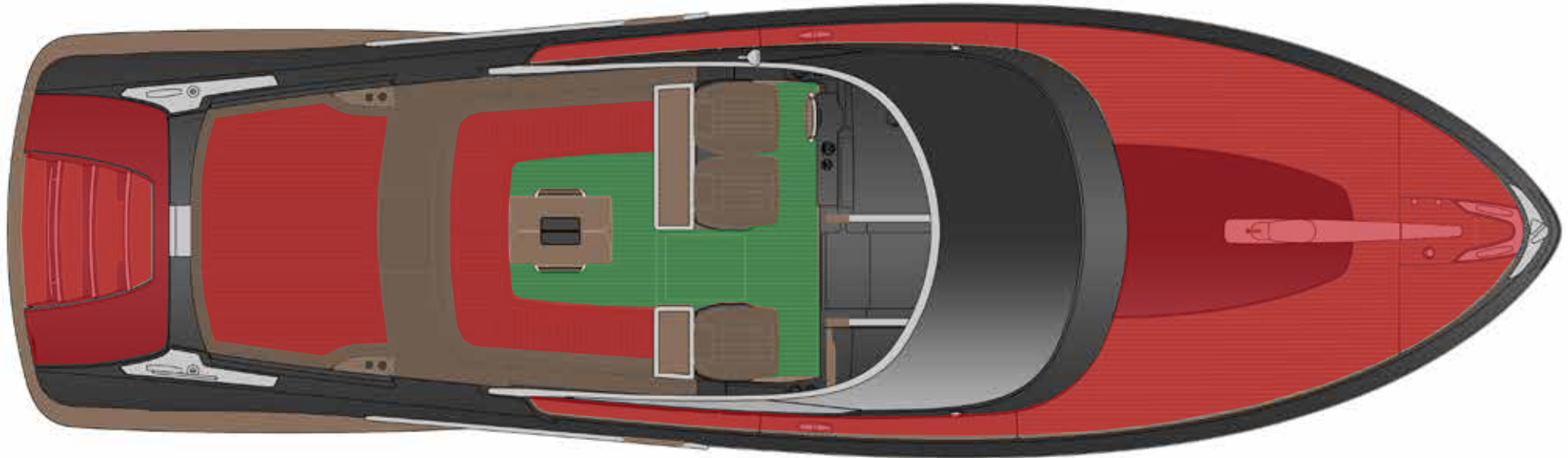

CAUTION

All the areas where there is polished fibreglass are no-step areas.



ICONA ICON	DESCRIZIONE DESCRIPTION
	<p>Ponte di lavoro: Durante la navigazione, in questa zona, evidenziata in verde è possibile sostare e camminare; non è invece possibile sostare o camminare sulle sedute del pozzetto.</p> <p>Working deck: Standing or walking is allowed in this area, highlighted in green, during navigation, while it is forbidden to stand or walk on the cockpit seats.</p>
	<p>Aree interdette: I camminamenti laterali, la parte di coperta a prua e la piattaforma di poppa, evidenziati in rosso, non sono considerati "ponte di lavoro".</p> <p>Forbidden areas: The side walk-around, the bow deck and the stern platform, highlighted in red, are not considered as "working deck".</p>

Handles in the working deck area

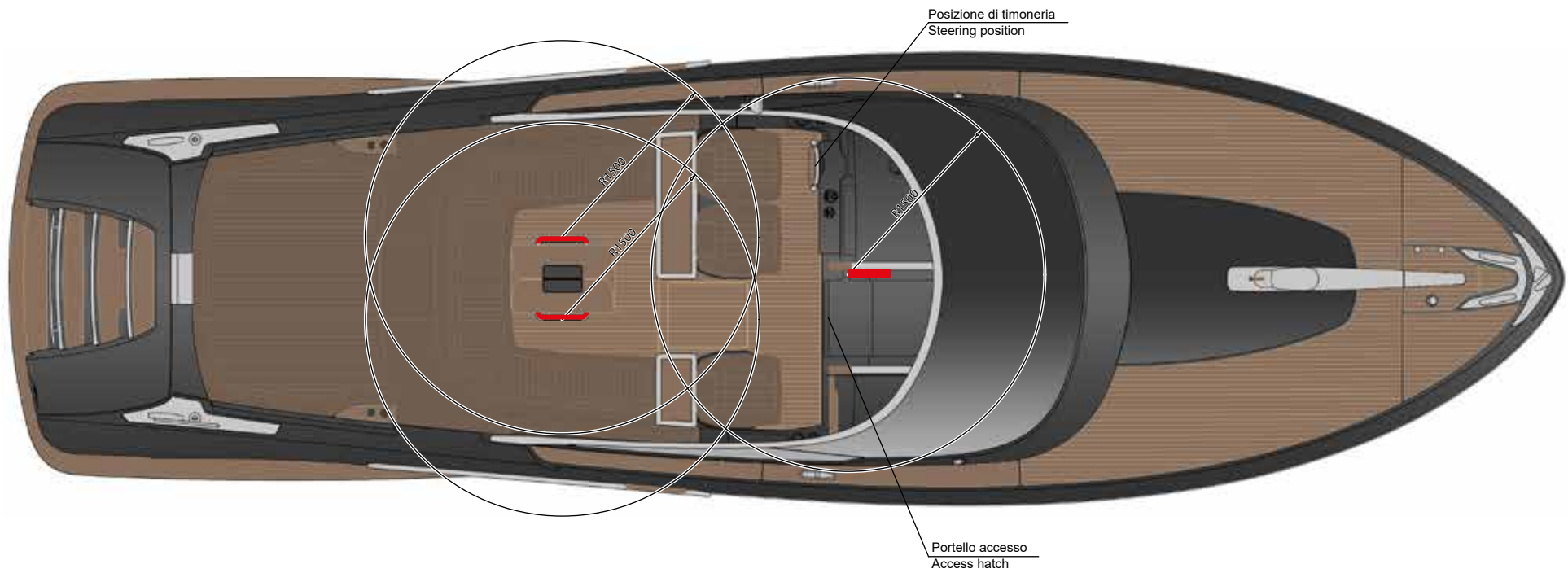

Hooking points in the working deck area

Hooking points were provided on board the yacht in order to be able to move around safely.

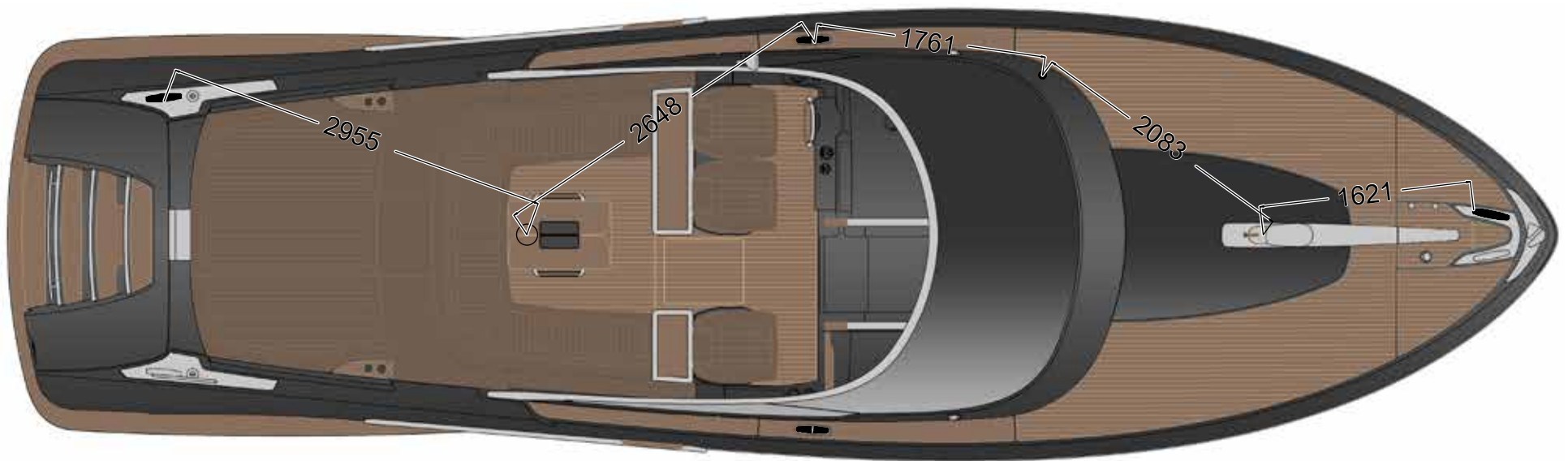

2.7 FIRE-FIGHTING SYSTEM

RIVA has made every effort, both as regards design and construction, to minimize the risk of on-board fires.

Once the fire has been extinguished, it is important to identify the cause that triggered it (if this has not already been done previously) and, if possible, to eliminate it, or at least to take proper corrective actions.

Fire-fighting protection of the yacht is made up as follows:

- Engine room fixed gas fire-fighting system (1);
- Technical room fixed gas fire-fighting system (2);
- High temperature sensors in engine room and technical room;
- Portable dry-chemical extinguishers (n°2);
- Safety plates.

NOTE

The equipment described above must only be used for its envisaged purpose.
No other use is allowed under current rules.



DANGER

Do not store flammable materials such as gas bottles, fuel containers, spray cans, etc.. in the engine compartment or near heat sources. These objects must be stored in ventilated rooms and, if possible, on the outside.

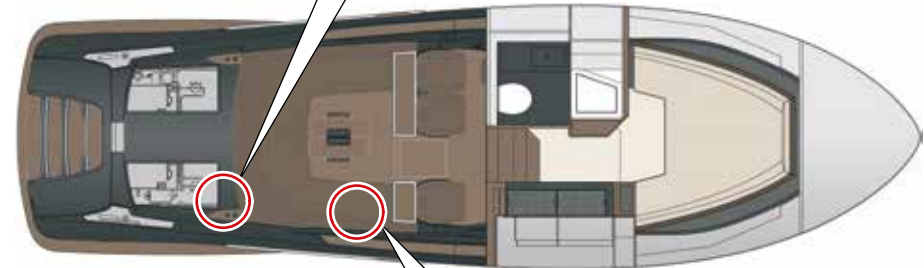

**DANGER**

Before activating the engine room fire fighting system make sure that no people is inside the room.

Do not open the engine room or utility room access hatch until you are absolutely sure that the fire has been extinguished.

After the discharge, wait for a sufficient lapse of time and verify that the fire is out. Ventilate the room before entering it for inspecting it thoroughly.

**DANGER**

Keep the fire-fighting control rod system efficient by having the periodic maintenance and functional checks carried out by skilled personnel.

**DANGER**

Pay the utmost attention when touching equipment in general. It may still be very hot and can cause burns.

2.7.1 Automatic fire-fighting system

Each fire fighting system is composed of an automatics gas extinguisher, located inside the room.

The gas fire fighting system installed on board has been designed to complete the discharge in a few seconds from the activation. In this way it is possible to reduce the time in which the fire can develop and expand, thus causing damages.

Delivered, the gas reaches all areas of the protected room (engine room and/or utility room), does not damage the most delicate equipment and does not leave residuals.

It allows avoiding also the costs inherent to cleaning and operation restoration, therefore it allows resuming immediately the activities on-board.

The discharge is automatically activated by means of a sprinkler, installed on the bottle and filled with liquid that, when the room's temperature increases, expands and breaks the sprinkler itself, causing system activation.

The automatic fire extinguishing system is managed by an electronic control unit (SHUT DOWN). In case of fire in the engine room or the technical room, the time when the discharge the extinguisher is activated, the control unit stops the propulsion engine, the generator and the engine room extractors and the technical room extractor; take anyway on the bridge and put the keys of the engines ignition in OFF.

The automatic fire-fighting system may not activate in particular fire conditions; it is therefore necessary to act on the safety rods to activate the fire-fighting systems manually.

**DANGER**

The automatic fire fighting system that protects the engine compartment and the system room may not start under particular fire conditions and, therefore, it is ALWAYS COMPULSORY TO MANUALLY OPERATE THE FIRE FIGHTING CONTROL TIE RODS.

**CAUTION**

If a fire is detected, it is necessary to manually operate the system, without waiting for the automatic activation, in order to minimise the damage.

The tie rods for fire fighting system manual activation of engine room and technical room are located on the starboard side, opposite to the helm position.

Operating the handle of the tie rod of the room involved in the fire, by means of a sheathed steel cable, it is possible to activate the relevant bottle's discharge, if the discharge has not yet been activated automatically, and simultaneously the SHUT DOWN system stops the fuel supply (engine room) and stops the air extractors (engine room and technical room).

The fire fighting control tie rod carries out the following functions:

- It stops the propulsion engines.
- It stops the air extractors.
- It stops the electrical system.
- It activates the gas fire fighting system.

1. Fuel interception tie rods
2. Fire fighting activation tie rods
3. Status panel charging of fire extinguishers



**DANGER**

Each fire extinguishing tie rod is provided with a safety pin, that must always be inserted in order to avoid accidental discharges of the gas fire extinguisher.

The safety pin, when inserted, prevents discharge activation by means of the tie rod. The safety pin must be removed only when you intend to operate the extinguisher discharge tie rod.

On the main deck, the starboard side, opposite to the console is the panel that indicates the state of charge of the engine room fire extinguishers **(3)**.

In case of fire in the engine room, carry out the following operations as soon as possible:

- Stopping the propulsion engines through the special engines keys, turn OFF the generator and engine room extractors acting directly on the electrical panel.
- Disconnect the battery breakers and all AC input magneto-thermal switches, in order to avoid feeding fires and short-circuits.
- Reach the fire fighting control tie rod.
- After having removed the tie rod's safety pin, operate the handle pulling it towards yourself, in order to:
 - Close the main engines and generator fuel supply circuits;
 - Stop the air extractors;
 - Activate the engine room gas extinguisher discharge.
- The system may have already been activated by the automatic system, however it is advisable to operate the tie rods in any case.
- If the fire breaks out while the yacht is underway, carry out the "MAY DAY" distress call; if the fire breaks out while moored in the harbour, alert the Harbour Authorities and the surrounding yachts, and evacuate all non-necessary personnel.

In case of fire in the utility room, carry out the following operations as soon as possible:

- Stop the utility room's air extractor.
- Disconnect the battery breakers and all AC input magneto-thermal switches, in order to avoid feeding fires and short-circuits.
- Reach the fire fighting control tie rod.
- After having removed the tie rod's safety pin, operate the handle pulling it towards yourself, in order to:
 - Activate the technical room gas extinguisher discharge.
- The system may have already been activated by the automatic system, however it is advisable to operate the tie rod in any case.
- If the fire breaks out while the yacht is underway, carry out the "MAY DAY" distress call; if the fire breaks out while moored in the harbour, alert the Harbour Authorities and the surrounding yachts, and evacuate all non-necessary personnel.

In addition, there is the control panel **(1)**, equipped with optical and acoustic alarm, manages and monitors the sprinkler system of the engine room:

- **Green light**
Indicates that the fire extinguisher is charged.
- **Red light**
Indicates that the fire extinguishers is not charged.
- **SILENCE button**
It turns off the acoustic signal which indicates that the system is operating and that the extinguisher is releasing gas.
- **DIMMER**
It varies the brightness of the control lights of the CHARGE/ OVERRIDE panel.
- **OVERRIDE button**
 - When this button is pressed, the control unit which, in case of extinguisher discharge, stops the engines, generators and electric extractors, is cut OFF.
 - In OVERRIDE position the control unit is disabled.

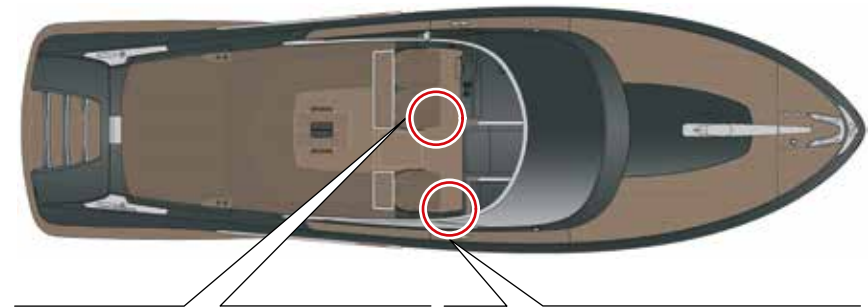

DANGER

In case of fire, use the "OVERRIDE" to restart the engines, only in case of collision risk or during navigation in narrow waters.

Engine compartment fire extinguishing system diagram

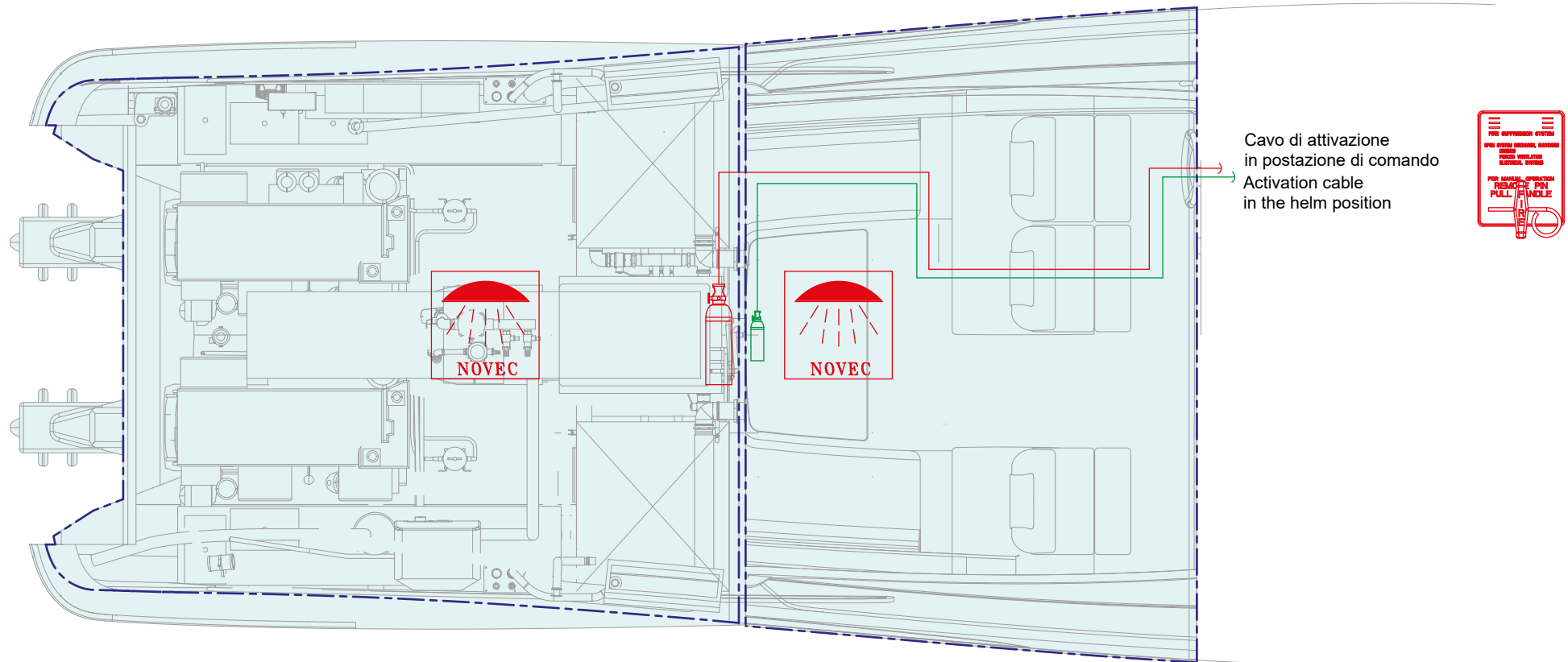

Cavo di attivazione
in postazione di comando
Activation cable
in the helm position



ICONA ICON	DESCRIZIONE DESCRIPTION
	Estintore sala macchine Engine room extinguisher
	Estintore locale tecnico Technical room extinguisher
	Spazio protetto Protected space

ICONA ICON	DESCRIZIONE DESCRIPTION
	Guaina Sheath
	Tirante Tie-beam
	Spazio protetto Protected space

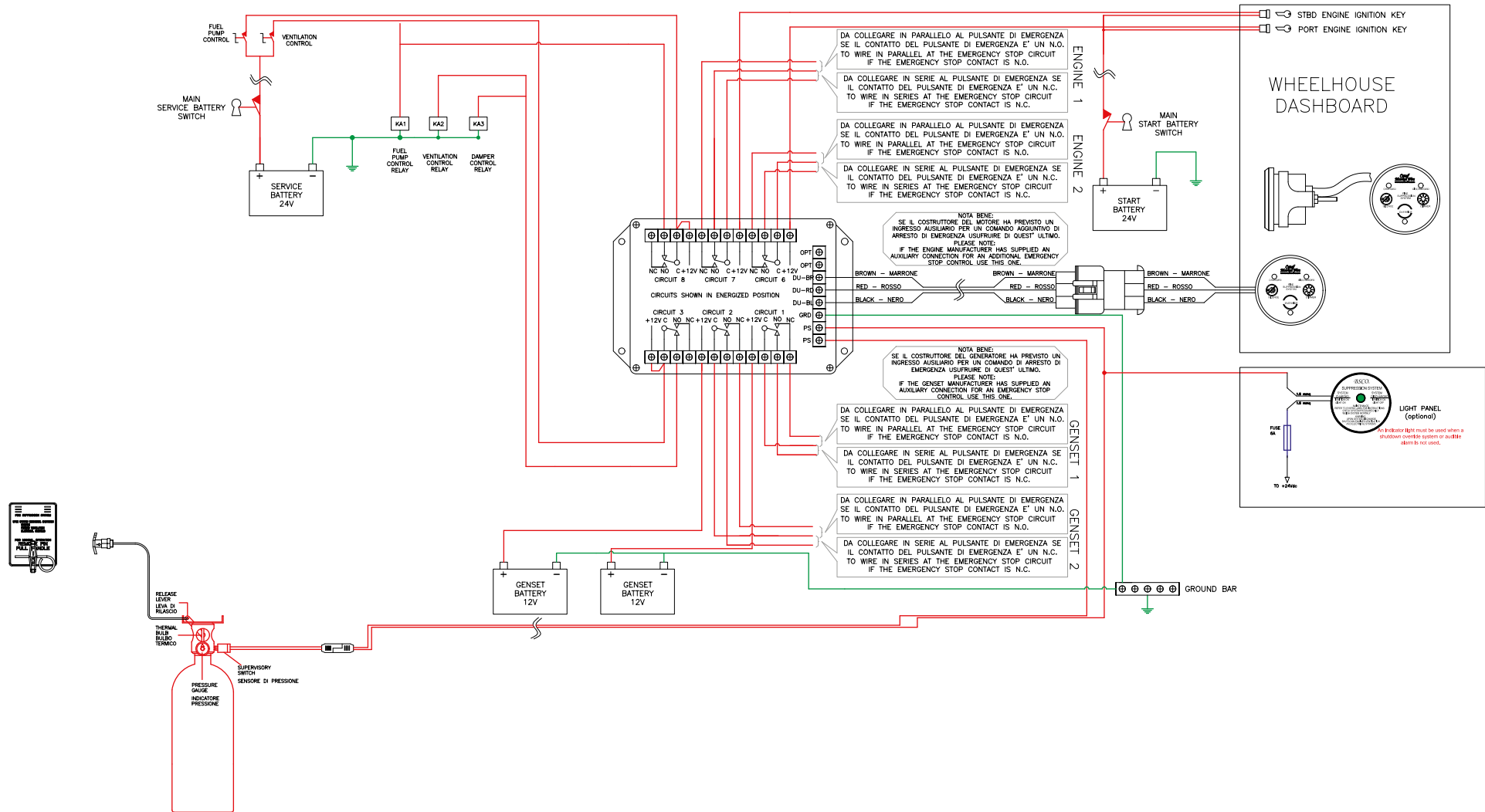

2.7.2 Maintenance fire protection system

Have the system overhauled by a qualified service centre according to the manufacturer's instructions.

Check the discharge indicator before use, to make sure that the fixed fire-fighting system has not been discharged.

Check the status of the fire prevention system from the helm position control panel (green charge light ON).

The fixed fire prevention system must be examined at least once a month and in any case before each journey to sea.

- For corrosion.
- To ensure that access to the controls is not obstructed.
- To ensure that the cylinder is securely positioned.
- To ensure that the pull cable is not broken, slack, damaged or kinked.
- To make sure that the cable connections are fastened properly.
- To make sure that the system has not discharged.



CAUTION

The extinguisher CONTAINS TOXIC CONCENTRATED CHEMICAL AGENTS AND SUB PRODUCTS FOR FIRE FIGHTING. Avoid inhaling fumes or long exposure to them.

THE ACCIDENTAL DRAIN DURING USE OR INSTALLATION CAN CAUSE SERIOUS INJURIES.

Never let it drop down. Keep it far from extreme heat.



DANGER

The presence of the safety pin inserted prevents the activation of the manual discharge (by means of tie rods).



CAUTION

Carefully read the instruction manual.

Before attempting any installation, removal, activation or maintenance of this device.



CAUTION

During maintenance operations, pay attention not to break the flasks unintentionally, in order to prevent accidental cylinder releases.



CAUTION

Check that at environment temperature the cylinders pressure gauge is set to correct actuation position indicated by the supplier.

MAINTENANCE

At least once a month, and in any case, before each navigation, check the charge status of the fire extinguisher.

At least once a month, and anyway before each navigation, check the external condition of the fire extinguisher. At least every 6 months check the fastening of the fire extinguisher.

Component	Maintenance	Notes and precautions
Gas fire extinguisher	Checks and tests	<p>Check the charge status by means of the pressure gauge installed on the cylinder. The charge status can also be checked also by measuring the cylinder weight.</p> <p>The extinguisher is properly charged when the pressure and weight values comply with the specification reported on the extinguisher tag.</p> <p>Before installing, weigh the extinguisher (bracket excluded) and record the date and weight on the special tag.</p> <p>Check the weight (bracket excluded) every six months: if the weight has decreased with respect to the previous checks, recharge or replace the extinguisher.</p> <p>Have the preservation status of the container (cylinder) checked by qualified technicians at least at the beginning of each season.</p>



DANGER

Accidental discharge of the fire extinguisher during handling or installation may cause serious injury. Insert the safety pin on the valve again until the installation or the check has been completed.
Protect your eyes during maintenance and installation operations.



DANGER

Once maintenance and installation have been completed, remove the safety pin from the extinguisher valve.



DANGER

During maintenance operations, pay attention not to unintentionally break the flask, because, even if the safety pin is inserted, if the flask breaks, the fire-fighting system activates.



DANGER

Before entering the engine room, it is necessary to ventilate the rooms properly, so as to avoid risks of burns and poisoning, due to high temperatures and to noxious gases suspended in the air.

2.7.3 Essential restoring for resuming navigation

If the fire-fighting system of the engine compartment has been activated and a fire has been extinguished, it is necessary to restore the essential conditions for navigation, in order to autonomously reach the nearest harbour in which to carry out the due checks.

To resume navigation, the ventilation system of the engine compartment and the fuel system of the propulsion engines must be brought back to normal working condition.

In order to allow starting the propulsion engines and the generator and re-starting the air extractors, set the fire fighting control panel switch to OVER-RIDE.



DANGER

Restoring the fire-fighting system with the aim of resuming cruising is an advisable operation only when the fire has not caused damage to the structure or to critical systems of the yacht.

In such a case, or should you have any doubt, it is essential to wait for rescue without resuming navigation.



DANGER

The operations for restoring the fire fighting system must be carried out directly from the engine compartment; therefore, before carrying out any operation, carefully read the safety instructions reported in the this manual.

If the fire has only involved the system room, after you have made sure that the fire has been extinguished, restore the room ventilation by means of its extractor.



CAUTION

Once the fire prevention system is restored, the extinguisher will be empty and no longer effective in the event of fire.

Once back in port, the fire extinguisher must be recharged by authorised personnel.

2.8 ALARM DEVICES

High temperature detection system installed on the yacht is an essential surveillance component for preventing any fires that may occur during operation.

This system consists of a detector positioned in the engine compartment. In the event of high temperature in the engine compartment (above 57°C), the detector activates the alarm siren and the light located on the helm position.

The temperature detection system is directly connected to the batteries, allowing its operation also while the yacht is left unattended and when the battery breakers are OFF.

2.9 NAVIGATION LIGHTS AND DAYLIGHTS SIGNALS

2.9.1 Navigation lights

The rules relevant to the navigation lights must be observed from sunset to dawn and during this period no other lights must be visible except the lights that cannot be exchanged for those specified in this manual.

Although the lighting system is preset by the Manufacturers, the Owner/Captain has the responsibility for the observance of the local rules.

Please note that the local and international rules relevant to lighting can slightly vary, we suggest therefore to gather information about the local rules of your area.

Night navigation requires more precaution.

All rules are applicable but apart from the right of course, it is advisable to slow down and to keep the proper distance from other boats.

It is a good rule to remember that bright lights reduce visibility at night.

Red/green lights (red to port, green to starboard)

Visibility range 112° 30' each.

Shown by any moving yacht and caused by any reason.

Anchor riding light (white)

Visibility range 360°, can be seen from any point of the horizon.

Seen from every anchored or under navigation yacht, or in specific circumstances.

The signal mast, which carries the navigation lights and the riding light on its end, is stored under the captain's seat structure, when not used.



CAUTION

The positioning of the navigation lights is optimised by adapting the regulatory requirements to the geometry of the yacht, providing lights where they are most easily visible.

Non-steering lights (N.U.C. = Not Under Command) and a bell are not included in the on-board equipment.

The fitting of lights and sound signals is subject to the approval of the Flag Administration where the yacht is registered.



WARNING

Navigation lights, shapes and sound signals.

Where navigation lights, shapes and sound signals are installed, they must be in conformity with COLREG 1972 (II International Regulations for Preventing Collisions at Sea) or CEVNI (European Code for Inland Waterways). Regulations depending on the case.

MAINTENANCE

At least once a week check the operation of the navigation lights.

At least once a week carry out accurate cleaning of glasses and headlights.

At least once every six months check the presence of corrosion in the connections of the navigation light cables.

At least once every six months, tighten the cable connections of the navigation lights.

The use of lights during the various situations of use of the yacht during night navigation are illustrated below:

- **Navigation:** Masthead lights, side lights and stern lights ON.
- **At anchor:** Anchor lights ON.
- **Drifting:** Two red lights ON (no steering mast installed).
- **Stranded:** Anchor light and two red lights ON (no steering mast installed).



CAUTION

For the use of navigation lights, the installation of the mast with the anchor light is required. It takes over the function of the mast head and stern light at the same time during navigation.

NOTE

Before undertaking any navigation, the Captain should make sure that all navigation lights are operating correctly. Use the navigation lights in compliance with the regulations in force.

To extract the signal mast: Lift the seat of the captain couch. Rotate the cap of the installation hole mast signals.

Enter the signal mast in the hole until it stops.



CAUTION

When the light mast is removed from its navigation position, store it onto the dedicated supports. Never leave the support base (electric connection) uncovered, but completely insert the relevant cover cap.



DANGER

During the installation operations of the anchor light mast, proceed with care on the main deck, side walk-arounds, because of the slippery surfaces.



CAUTION

The lights must exclusively be cleaned with fresh water not containing solvents or abrasive substances. Solvents may damage the lens of the navigation lights.



DANGER

Never use the lights mast as a handhold.

Navigation lights, sound signals and daylight signals

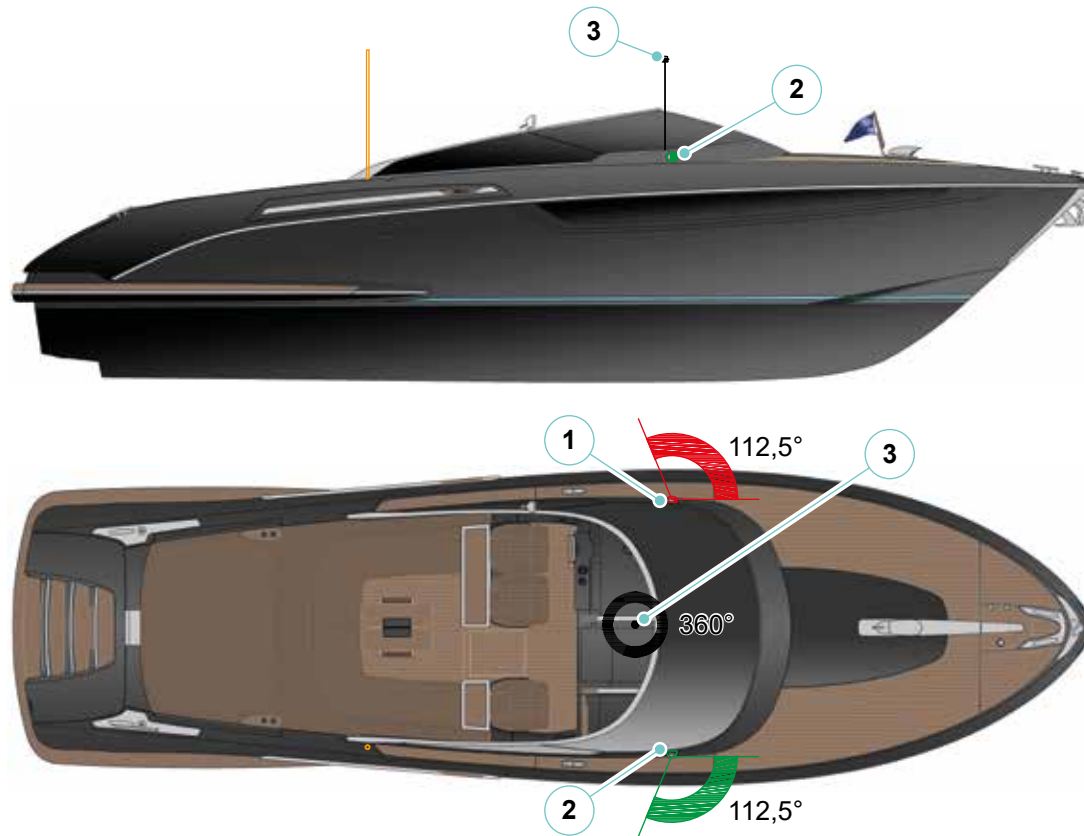

ICONA ICON	DESCRIZIONE DESCRIPTION	ANGOLO ANGLE	COLORE COLOUR	VISIBILITÀ VISIBILITY
1	Fanale di via sinistro Port side light	112,5°	Rosso Red	2 miglia 2 miles
2	Fanale di via destro Starboard side light	112,5°	Verde Green	
3	Fanale di fonda Anchor light	360°	Bianco White	

2.9.2 Daylights signals

In order to increase the safety of people on board, the manufacturer has provided the installation of a mast for daytime shapes, in accordance with Directive 2013/53/EU.

NOTE

The combined use of shapes, sound signals and navigation lights increases the visibility of the yacht, reducing the risk of collisions.

Daytime signals have the same function as navigation lights but are more visible during the day than navigation lights.

Depending on the situation, appropriate signalling templates shall be used.

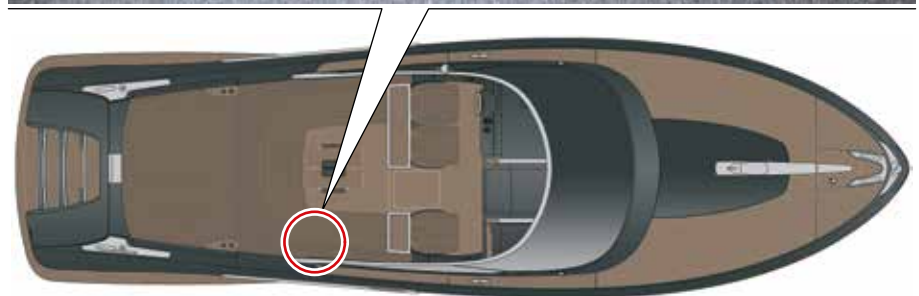

Hereunder is a list of the most common ones to adopt after installing the relevant mast:

- Boat at anchor:



- Not Under Command boat:



- Stranded boat:



- Boat with limited manoeuvrability:



- Boat to trailer or towed:



2.10 MANDATORY SAFETY EQUIPMENT

In order to ensure proper safety conditions of the yacht, the Owner is obliged to maintain the yacht in good working order and state of repair, as well as to provide for the replacement of equipment, life-saving equipment and safety equipment that present deterioration or defects that may compromise proper function.

In addition to the equipment provided by RIVA, the Owner is responsible for providing the yacht with any further system and safety/marine equipment required by the rules in force in the nation where the yacht is used, according to weather and sea conditions and to the distance from safe harbours along the intended course.



DANGER

Rescue equipment must be arranged so as that when it is launched there are no obstacles to free floating and must be equipped with proper fitting allowing for quick release from the yacht when at sea.

NOTE

Refer to the local Port Authorities for instructions and changes of the Safety Rules in force in the country where you are.



WARNING

The safety systems must comply with local and international navigation laws and must be periodically reviewed by specialised companies within the dates indicated on the systems themselves.

2.11 LOCATION OF SAFETY PLATES

The plates applied on the yacht are used to point out special risks: each plate is located on the part of the yacht which can be a source of risk. Before working with or on this part of the yacht, read the safety warning carefully.

Keep all the plates clean and readable, replace them if missing or damaged.

The extinguisher positioning plates are located close to the extinguishers.



CAUTION

It is prohibited to remove or damage the safety plates on the yacht.

2.12 SCHEDULE

Minimum rescue facilities and safety equipment to be kept on board of yachts and pleasure yachts with no limit of distance from the shore and with expiry date.

	2026	2027	2028	2029	2030	2031	2032	2033	2034
Self-inflatable life raft (for all persons on board)									
Individual life buoy (for each person on board)									
Life jacket with rope (floating type)									
Light buoy									
Smoke buoy									
Red light hand fires									
Red signal rockets with parachute									
Compass and deviation schedules									
Nautical charts									
First aid kit									
RTF inspection									
Property tax									
Insurance									
License (pilot)									
Portable fire extinguishers									
Fixed fire extinguisher in the engine compartment									
E.p.i.r.b.									

Riva

RIVAMARE CENTO

DESCRIPTION OF THE YACHT

CHAPTER 3

3.1 MAIN DIMENSIONS AND CHARACTERISTIC DATA OF THE YACHT

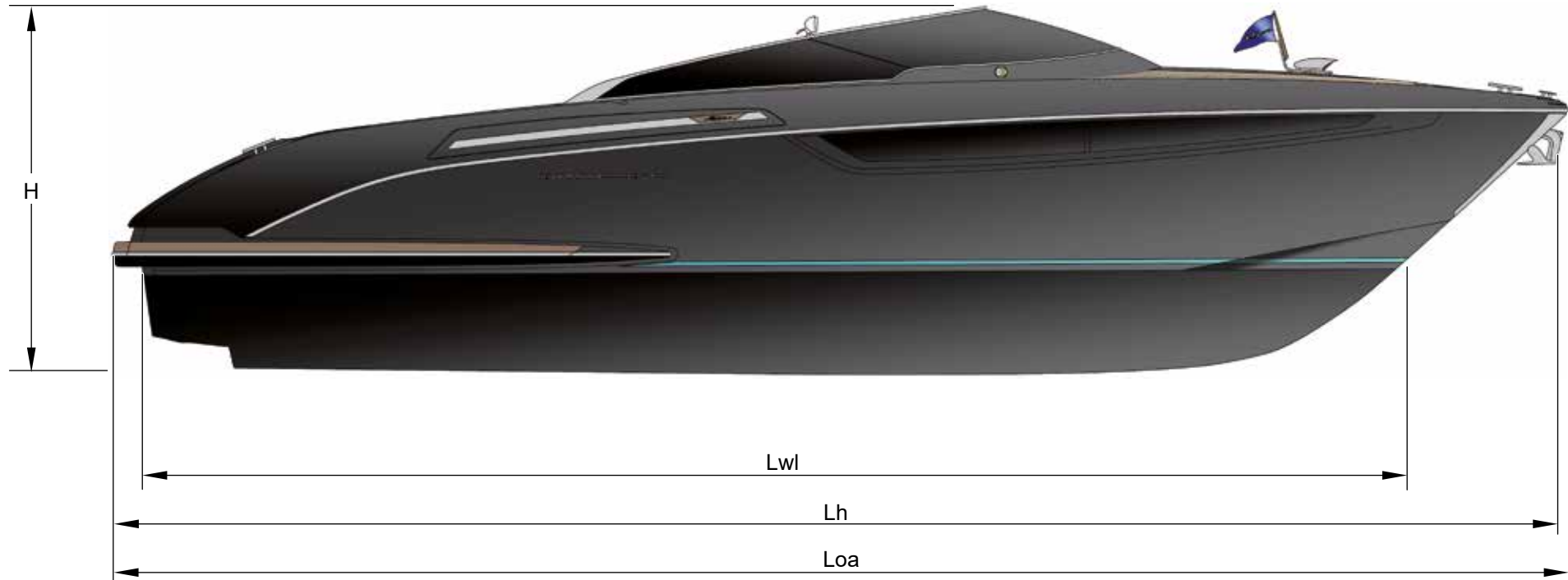

Overall length (Loa)	11,88 m	39 ft 0 in
Hull length (Lh)	11,72 m	38 ft 5 in
Waterline length (Yacht fully laden) (Lwl)	10,14 m	33 ft 3 in
Pulpit + platform connected to the hull	0,16 m	0 ft 6 in
Overall height from keel to windscreen (H)	3 m	9 ft 10 in

Depth under propellers (Yacht fully laden)	1,20 m	3 ft 11 in
Maximum beam	3,50 m	11 ft 6 in
Displacement unladen	10 ton	22046 lb
Displacement laden	12,5 ton	27498 lb

Technical data		
Hull type		Warped hull with spray rails and aft deadrise 15°
Construction material		Fibreglass
Propulsion	Model	2 x Volvo Penta D6-400 DPI
	Configuration	In-line 6 cylinder
	Power	400 mhp (294 kW)
	rpm	3500
	Dry weight	780 kg (1720 lb)
Inverter	Displacement	5.5 lt (336 in ³)
	Model	2x D6 - DPI
	Fuel tank capacity	(lt) approximately 1000 litres - 264 gals
	Water tank capacity	(lt) approximately 330 litres - 87 gals
	Black water tank capacity	(lt) approximately 38 litres - 10 gals
Total weight of liquids (full tanks)	(kg) approximately 1368 kg (3.016 lb)	
On board electric power supply	(V)	230V single phase shore power
	(V)	12V from batteries
Batteries	Engines (n°)	2x 12V 120Ah
	Services (n°)	2x 12V 120Ah
	Auxiliary services (n°)	1x 12V 120Ah
Bilge pumps	Engine compartment (n°)	1
	Technical compartment (n°)	1
	Cabin (n°)	1

**CAUTION**

RIVA yachts are designed to obtain a correct transversal trim with full optional equipment, as well as spare propellers and shafts. If the yacht is not provided with full optional and with spare propellers and shafts, some weights are inserted to correct the transversal trim. The above-mentioned weights can be removed or displaced as soon as the yacht is provided with a new equipment.

**CAUTION**

Any change in the disposition of the masses aboard may significantly affect the stability, trim and performance of the craft.

NOTE

The technical specifications and the performances indicated are merely indicative, do not constitute an offer with the value of a contract in any way, and are referred to standard models of the motor yachts built by the Shipyard in the European version. The only technical indications or descriptions with contract value for the purchaser are those relevant to the specific yacht purchased and contained in the sale documents.

**WARNING**

When loading the yacht, never exceed the maximum recommended load. Always load the yacht carefully and distribute loads appropriately to maintain design trim (approximately level).

**CAUTION**

Bilge water should be kept to a minimum. Stability is reduced by any weight added high up. In the event of rough seas, doors, cabinets and doors must be closed to reduce the risk of flooding. Breaking waves are a serious stability hazard.

3.2 GENERAL YACHT LAYOUT AND SECTORS

This chapter contains a general description of the yacht and is supported by a set of illustrations thanks to which it is possible to easily locate the main areas and the different devices.

Advice and information on the correct use of the various instruments are also given.

The structure of the yacht has been divided as follows:

- Main Deck;
- Lower Deck;
- Engine room and technical room.

The yacht is provided with both electronic and mechanical devices and instruments; some of these are provided with their own user's manuals.

The information contained therein are an integral part of this Owner's Manual.

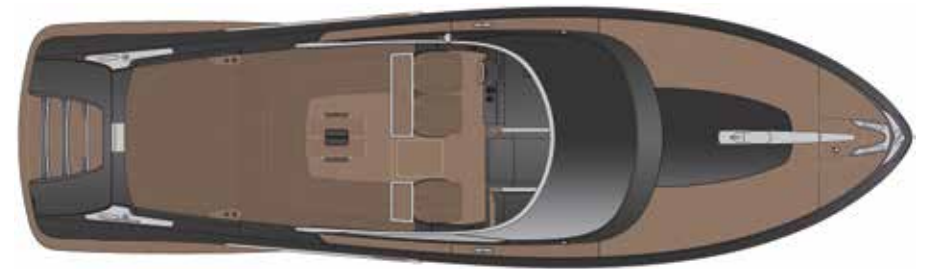

Main deck



Lower deck

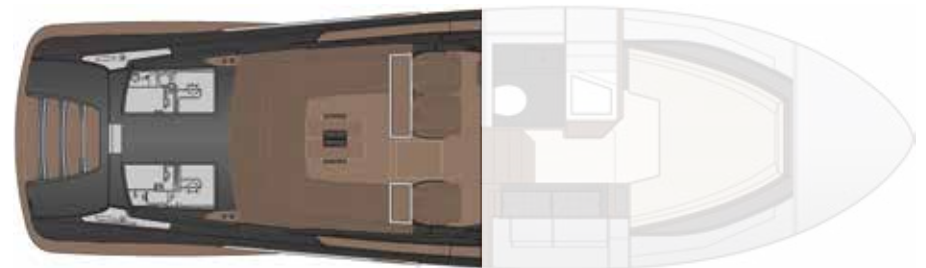

Engine room and technical room

3.3 MAIN DECK

The main deck consists of a large external area on which you can enjoy the luxury and comfort of your yacht in the open air.

The sofas in the cockpit and the bow and stern sun-bathing area are large and comfortable and equipped with high-quality accessories.

Besides the areas studied to ensure maximum comfort to the owner and his guests, the main deck is provided with a set of services and systems useful for navigation and for the mooring and anchoring phases.

1. Black water discharge on shore (WASTE)
2. Port stern peak
3. Shore socket peak
4. Fresh water inlet (WATER)
5. Stern sun-deck / engine room access
6. Cockpit table
7. Bar cabinet
8. Captain seats
9. Helm position
10. Windscreen
11. VHF aerial
12. Owner's cabin skylight
13. Chain, anchor winch and fenders peak
14. Bow fairleads and cleats
15. Lower deck access door
16. Searchlight
17. Technical room access hatch
18. Cockpit fridge
19. Starboard utility cabinet
20. Bimini seat cover
21. Fuel inlet (DIESEL)
22. Windscreen wiper
23. Cockpit sofa
24. Shower peak
25. Swim ladder
26. Starboard Peak for Seabob
27. Gangway

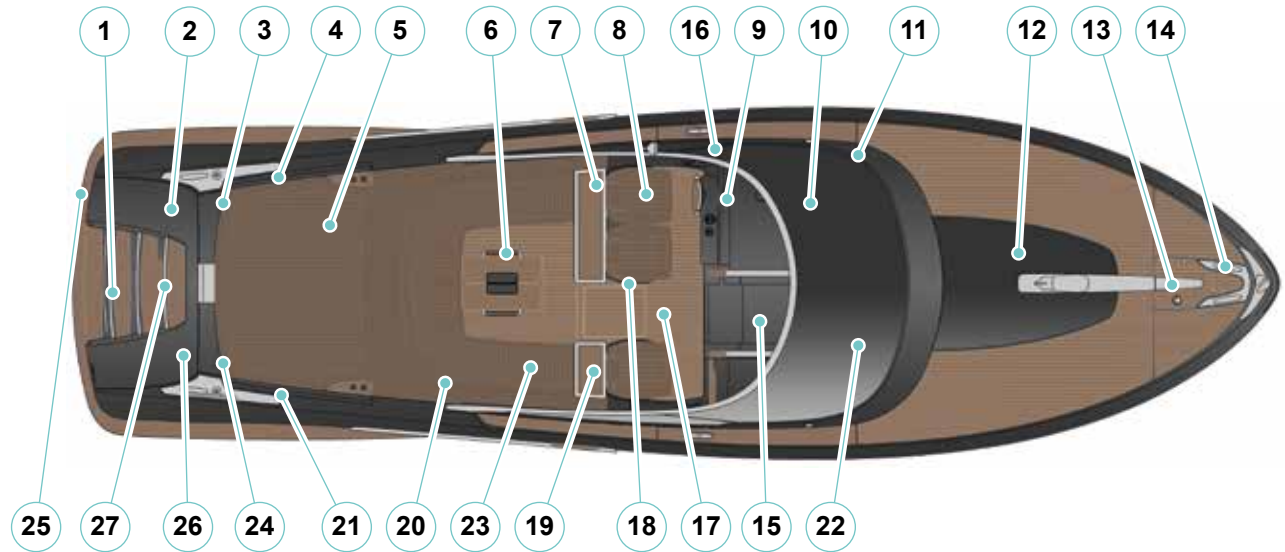

The shore power supply socket is located in the stern zone, on the port side.

The freshwater inlet is located on the aft of the port sun-deck.
The shower is located in the stern zone on the starboard side.
Inside the locker abaft the starboard sun-deck is the peak for the Seabob.

The swim ladder is located inside the seat in the stern platform.

In the central part of the stern zone is located the black water suction nozzle.

Through the central walkway between the two limits sun-deck aft / access doors to the engine room, you can access the cockpit.

The fuel inlet is located aft of the starboard sun-deck.

The cockpit area of the main deck contains a large area richly furnished for the social and convivial life of the Guests.

One comfortable sofa extend on the entire width and a table with folding top is located.

Fore of the cockpit there is the helm position, where all main yacht steering and control instruments are installed.

From the cockpit zone, all main deck equipment can be managed, such as the fire-fighting controls.

The cockpit zone is provided with important safety devices: the life rafts are located below the sofas and the portable fire extinguisher is located under the captain seat.

In order to access the life raft storage peak under the cushions of the cockpit sofa, after removing the cushions, it is necessary to completely lift and extract the hatch.

Under the cushions of the port cockpit sofa, for of the life raft storage peak, there is a compartment containing the individual life jackets.

To reach the life jackets, after removing the cushions, it will be necessary to lift the fibreglass panel by means of the relevant recess.



CAUTION

While removing the mobile parts described above, pay special attention not to hit and/or scratch the yacht.
Also pay attention in order to prevent passengers from standing in dangerous areas, especially in the area where operations are being carried out.

Beside the captain seats there is the access door to the technical room.
Under the captain seats there is a fridge.

The forward part of the cockpit has been arranged with two service areas.
To the port side is the bar cabinet.

The starboard side is a service unit with storage drawer.



CAUTION

Do not open and leave open the top of the bar unit in navigation.

All manoeuvres, operations, navigation control, telecommunications and yacht monitoring are carried out from the helm position (see chapter 4 “Helm position” in this manual). The captain’s seat consists in a folding seat.

**DANGER**

Only allow authorized and qualified personnel to use the devices installed in the helm position.

The personnel operating the yacht during the various activities on board must not be under the influence of alcohol, drugs or narcotics.

To the right of the helm position, by means of a comfortable staircase, it is possible to access the lower deck.

At bow of the yacht is located a sun-deck arranged with comfortable cushions. Aft the sun-deck there are a glass holder and two fixed skylights.

At the far end of the bow there are the necessary equipment for anchoring and mooring, and a wide peak containing the anchor chain.

The use of mooring and anchoring equipment is described in Chapter 6 “Information for use” in this manual.

The fore peak is equipped with a fresh water faucet, the anchor windlass and the relevant portable pushbutton control.

**DANGER**

It is forbidden, to stay or to walk on the walk-around and on the bow of the yacht during navigation, as the absence of a bulwark stay could expose people to the risk of falling at sea.

3.4 LOWER DECK

From the cockpit, through the staircase, it is possible to access the lower deck.

A double bed occupies the entire lower deck area.

On the starboard side there is a galley.

The bathroom is located on the port side.

1. Engine room
2. Technical room access
3. Technical room
4. Cockpit access stair
5. Main electrical panel
6. Galley
7. Owner's bed
8. Bow thruster engine inspection
9. Owner's bathroom
10. Fuel tank

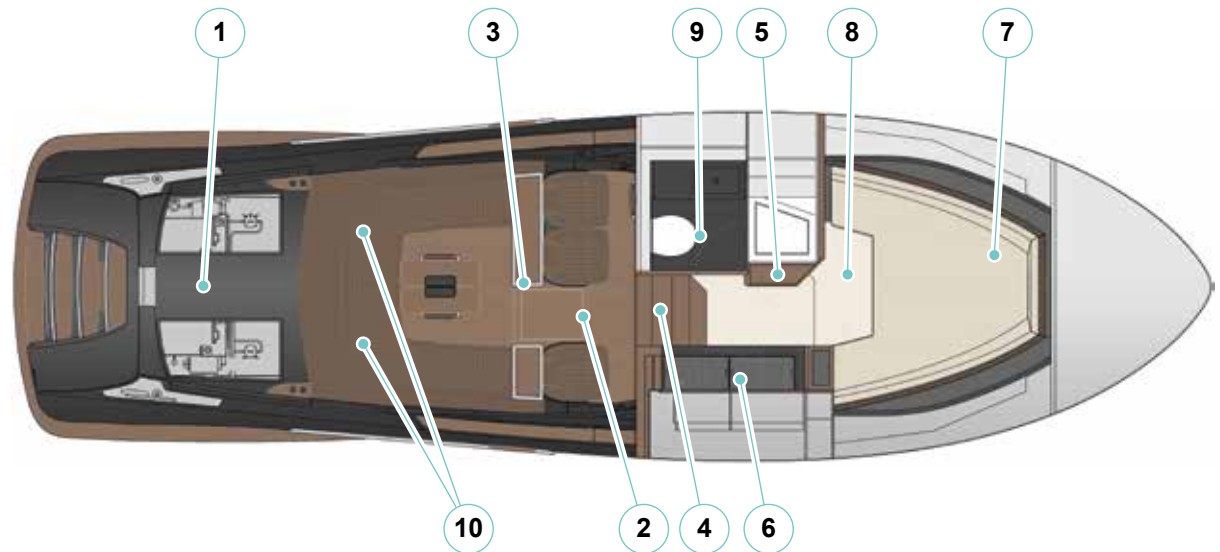

The galley is equipped with appliances such as stove with a fire stove, microwave and instant cooler bottles.

To power these devices need to turn ON the main breaker located on the electrical panel.

The worktop includes a sink supplied with cold and hot fresh water.



DANGER

Do not touch the cooking top during operation or when it is still hot.



CAUTION

Always check the absorption of the household appliances and deactivate them in case they are not used.



CAUTION

Do not leave pans unattended when they are on the burner. Do not cook during navigation.



CAUTION

It is recommended not to fill pots more than 50% with water and not to use pressure cookers.



CAUTION

When using the galley, increase the ventilation of the inner rooms as much as possible.

Never use the cooking top to heat the room.



CAUTION

Children are allowed to use the galley only when they are able to use its items correctly and to understand the dangers specified in the special instruction manuals. The help of an adult is required.



CAUTION

In order to eliminate smells, steams or fumes, it is necessary to turn on the suction hood at cooking start and to keep it on after cooking end for 10-15 minutes.



CAUTION

Do not put liquid food into the oven.



CAUTION

Never place metal containers with metal inserts and liquid food in the oven.

**CAUTION**

Please remember that the plate, even after use, can still be very hot for a long time, and that it may cause damage to property or scalds.

**CAUTION**

In case of navigation with rough sea, we recommend not to use the galley.

**CAUTION**

When the oven is in operation to keep open the door from the unit that contains it to increase aeration.

**CAUTION**

Keep the access to the helm position reserved to the Captain only, in order to prevent accidental alterations of the instruments carried out by incompetent persons.

**DANGER**

The personnel operating the yacht during the various activities on board must not be under the influence of alcohol, narcotics or drugs.

**CAUTION**

It is not recommended to move during navigation, because a lateral skid of the yacht, could have a negative effect on a moving passenger, causing an accidental fall or the impact against a piece of furniture.

**CAUTION**

Keep all on board steps clean and dry.

**CAUTION**

When the appliances contained within the mobile galley are in operation maintain the open cabinet doors.

NOTE

For further information on use and maintenance, please refer to the manufacturer's manual.

The galley is provided with instant refrigerator for bottles.

Temperature adjustment inside the instant refrigerator is carried out by means of the temperature switch (1) installed in the galley open compartment.

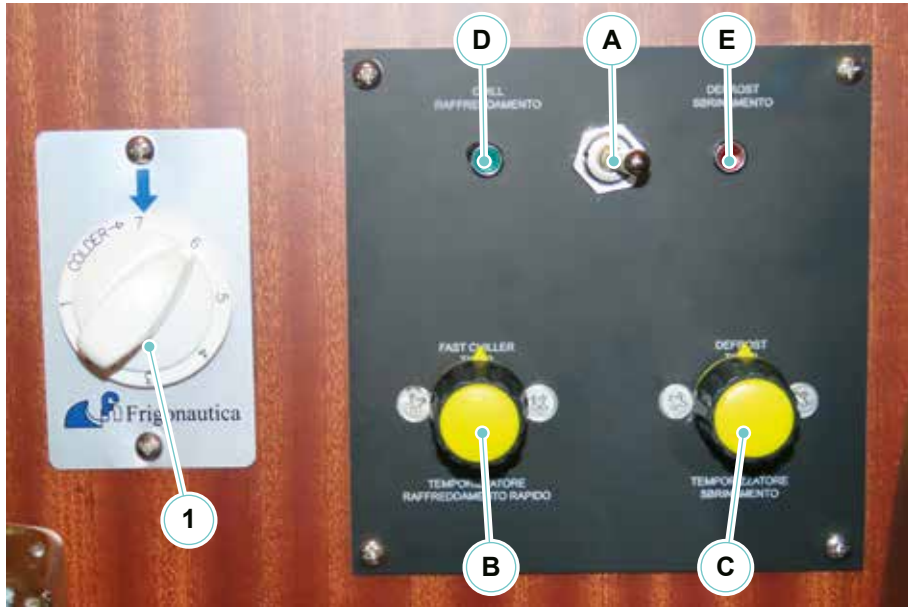

3.5 ENGINE ROOM AND TECHNICAL ROOM

The engine room can be accessed through the two hatches (1) located under the stern sun decks.

The hatches can be lifted electrically, the lifting device can be activated by means of the relevant controls in the helm position.

To supply the hatch push-buttons, it is necessary to activate the magneto-thermal switch located on the 12V utility electrical panel.

The engine room has been arranged as tidily as possible with engines and pipes, by installing the auxiliary engines as far as possible on resilients, to absorb vibrations. The engine room is provided with a watertight bulkhead; all tube passages towards the bow, and vice versa, are installed on the watertight bulkhead.

Further to the engine room, your yacht is provided with a technical room, which can be accessed from the cockpit through a hatch (2).

The technical room also houses further devices and technical systems.

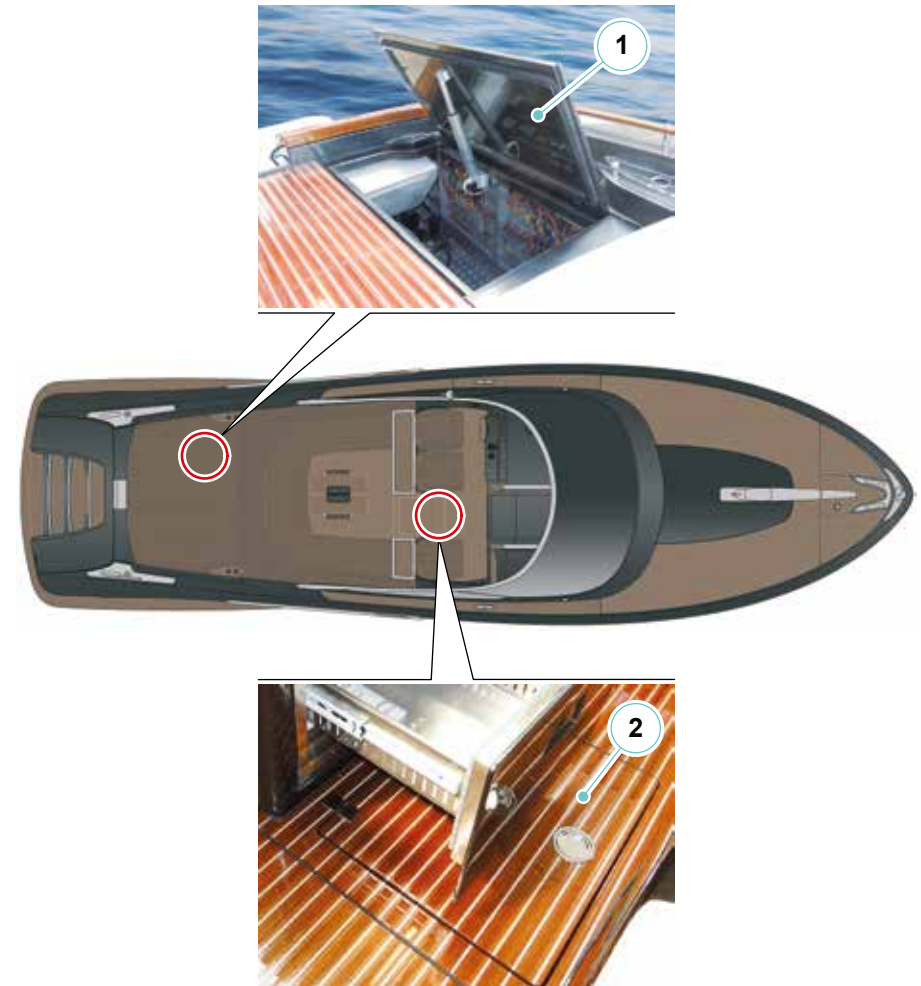

**DANGER**

In the engine room, the high temperatures due to the operation of the engines create strongly radiated areas, in which temperature remains high for a long time. Protect yourself and wait until they are cool before entering the engine room.

**DANGER**

During navigation, accessing the engine room and the system room is not allowed.

**CAUTION**

Do not store free-to-move items in the engine room and in the system room, as they might skid during navigation.

1. Port engine
2. Recessed plug
3. Starter battery
4. Charger
5. Box 230V
6. Fuse Box
7. Box 12V
8. Discharges to sea centralized claims
9. Hydraulic unit
10. Sea water strainer gyrosopic stabilizer
11. Port filter
12. Port fuel tank
13. Generator
14. Starboard fuel tank
15. Starboard filter
16. Generator sea water strainer
17. Generator muffler
18. Starboard drains centralized sea
19. Battery bow thruster
20. Box negative bar
21. Battery generator starter
22. Deposit generator exhaust
23. Battery auxiliary services (1)
24. Battery auxiliary services (2)
25. Discharge to the sea surrounded by water generator
26. Starboard reverse gear actuators
27. Starboard engine
28. Bilge pump engine room
29. Plug drain waste water at the shore
30. Port actuators reverse gear
31. Seawater discharge gyrosopic stabilizer
32. Autoclave
33. Port vent
34. Manifold bilge system
35. Manual bilge pump
36. Seawater pump gyrosopic stabilizer
37. Atomizer (optional)
38. Black water discharge seacock
39. Dashboard electronic box
40. Siphonbreak black water drain
41. Battery switch commands box
42. Black water tank
43. Terminal block
44. Technical room bilge pump
45. Bilge pump lower deck
46. Gray water tank
47. Gyrosopic stabilizer
48. Plenum for air intake
49. Group air conditioning
50. Water heater
51. Air conditioning seacock
52. Gray water sea discharge
53. Starboard vent nozzle
54. Air conditioning sea discharge
55. Fresh water tank
56. Generator seacock

Engine room and technical room diagram

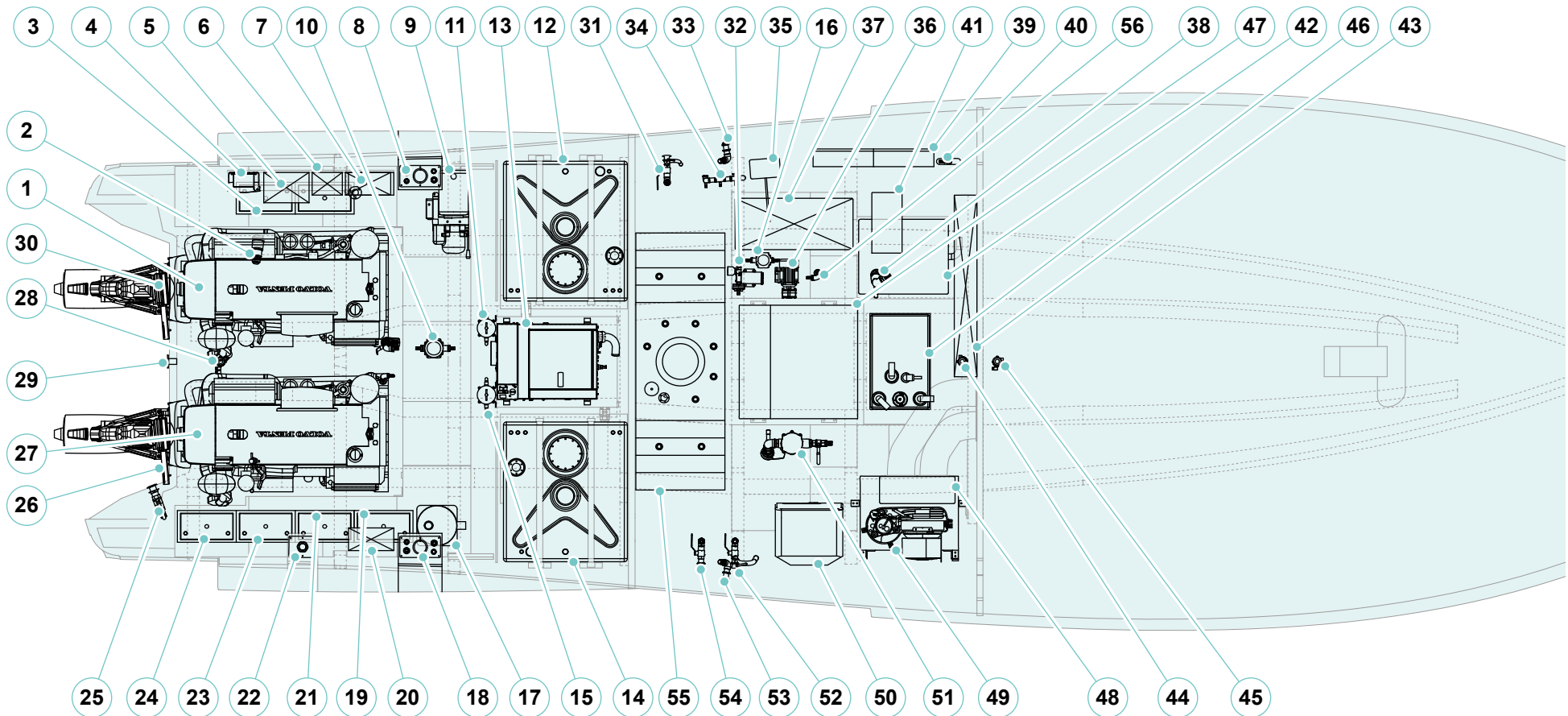

Riva

RIVAMARE CENTO

HELM POSITION

CHAPTER 4

4.1 HELM POSITION

All manoeuvres, operations, navigation control, telecommunications and yacht monitoring are carried out from the helm position of the main deck, with wide visibility and numerous instruments.

All devices prescribed by the various rules for safety at sea, fundamental for navigation, and the appliances required by the Owner are installed there. Each helm position component is supplied by a magneto-thermal switch located on the 12V utility main electrical panel.

The dashboard is divided into four sections:

- A. Front section
- B. Port section
- C. Starboard section
- D. Battery switches panel (under the Captain's seat)

The following describes in detail the various sections.



CAUTION

Herewith only general information for first start-up is given: in order to practice and for the specific use of the individual systems, see the manufacturers' manuals or contact RIVA After Sales & Service Department.



CAUTION

It is a good rule to keep the instruments clean by washing them with wet and clean rags, avoid using chemical products or abrasive ones. After navigation, it is advisable to cover instrumentation and equipment.

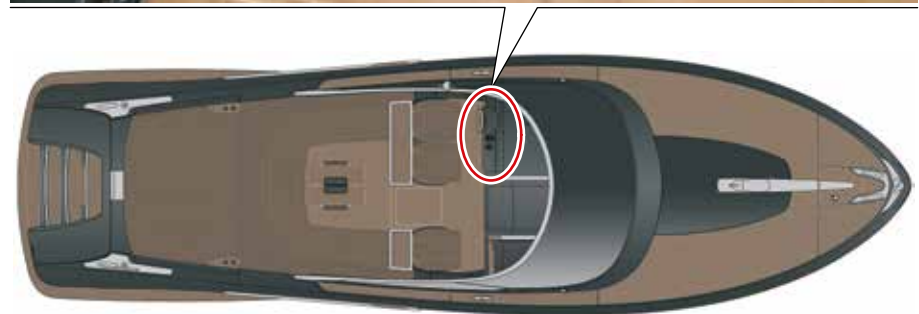
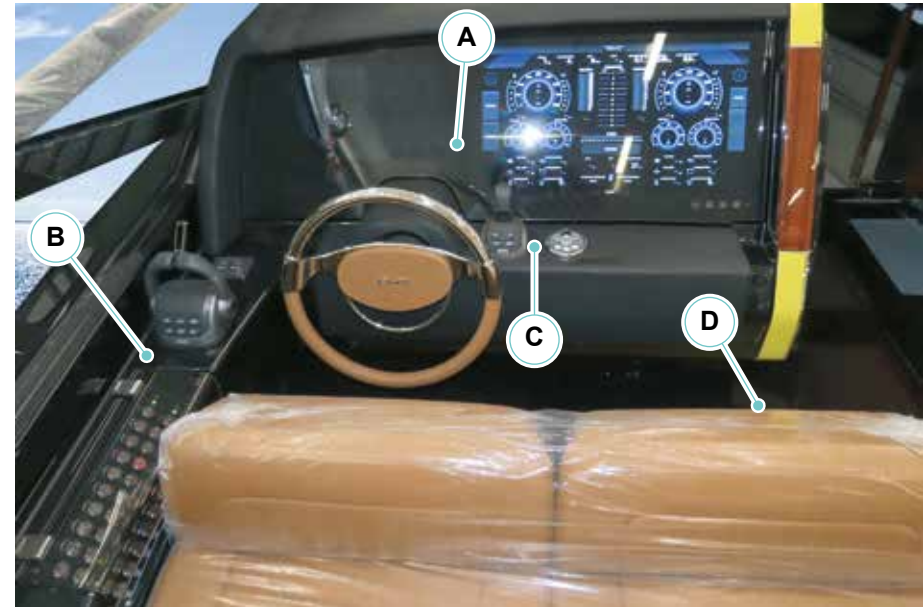

**CAUTION**

The helm position must be used only by the Captain or by the crew members authorised by the same.

The accidental activation of the controls installed in the helm position is a source of danger for the boat and its passengers.

**CAUTION**

All electric appliances for navigation, whose parameters can be configured and set by software through the control panel, have been configured and tested upon delivery.

These operations must only be carried out by authorised technical personnel.

Any modification of the preset configurations can alter the operation and reliability of the concerned system.

Appliances must be used by the personnel in charge of driving the yacht and of using the systems.

**CAUTION**

Refer to specific manuals concerning the electronic and electric instrumentation on board.

Observe the instruction given meticulously.

Field of view diagram

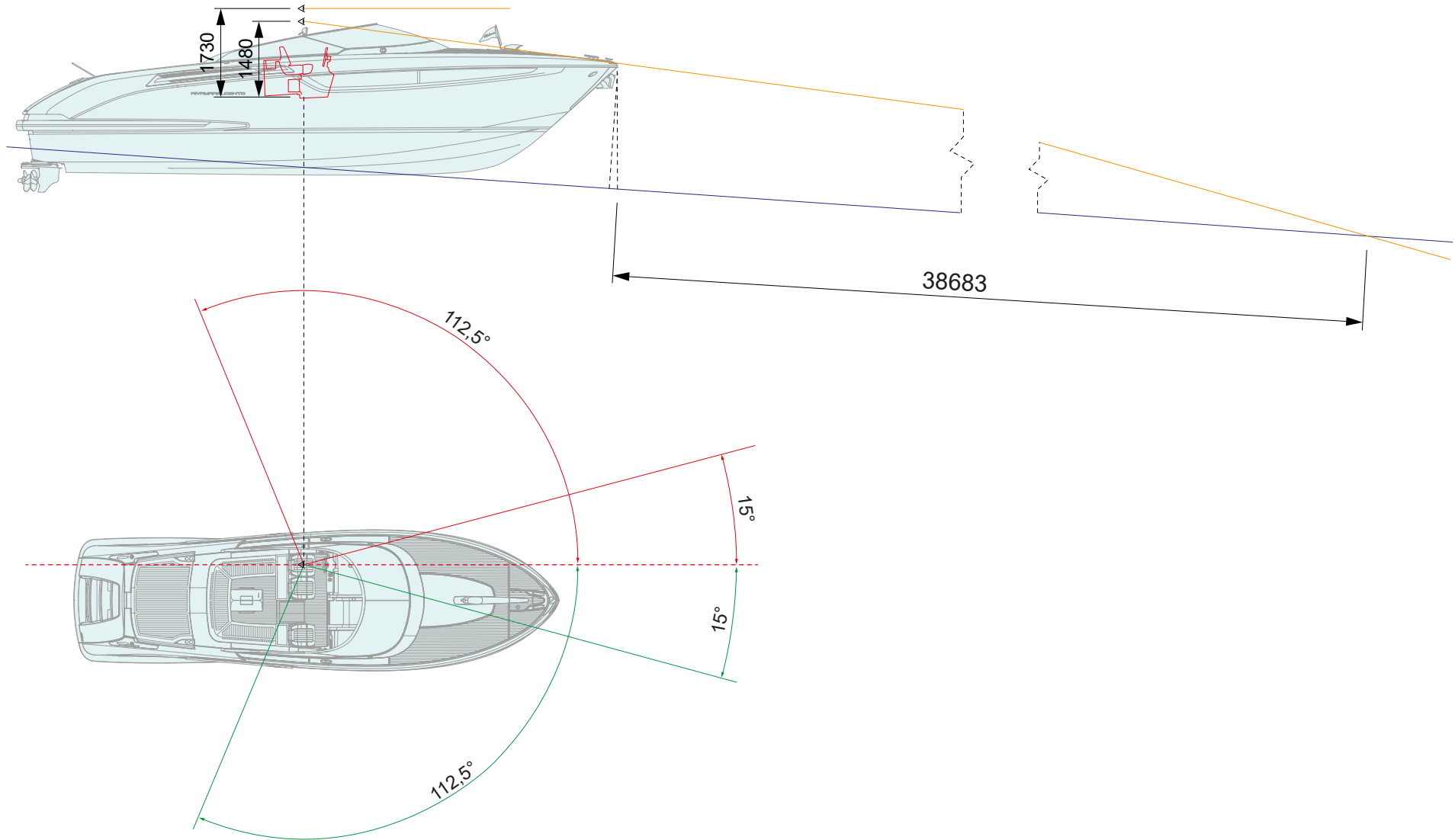

4.1.1 Front section

The front section of the helm position has the following utilities.

1. Digital display

Allows to monitoring and manage the on board systems.



4.1.2 Port section

The port section of the helm position is in turn divided into top and bottom and has the following utilities.

1. Synoptic panel with buttons and lights utilities:
 - Gangway operation control buttons
 - Cockpit table movement control buttons
 - Port engine room hatch control buttons
 - Starboard engine room hatch control buttons
 - Stern platform control buttons
 - Bimini control buttons
 - Windlass control buttons
 - Cockpit lights control button
 - Anchor lights control button
 - Underwater lights control button
 - Navigation lights control button
 - Bow hull lights control button
 - Searchlight control button
 - Blowers control button
 - Horn control button
 - Chain washer valve control button
 - Operating lights (ON / OFF) of bilge pumps 1, 2 and 3
2. Throttle (engine control system)
3. Engines start and stop panel
4. VHF speaker
5. Double USB socket
6. Stereo speaker
7. VHF
8. Bow thruster battery breaker

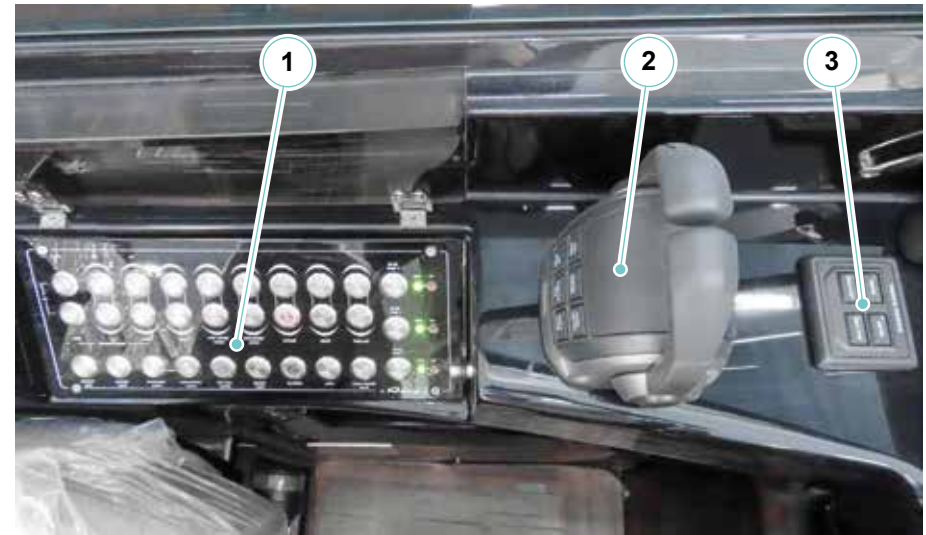

Upper section

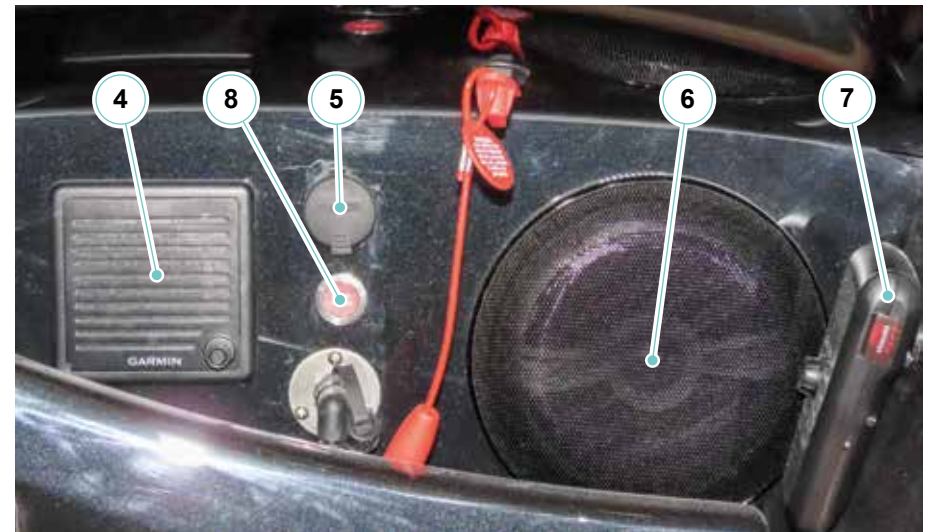

Bottom section

4.1.3 Starboard section

The starboard section of the helm position has the following utilities.

1. Engine manoeuvre joystick
2. Bow thruster control panel



4.1.4 Battery switches panel

The battery switch panel is located under the captain's seat and allows you to manage the operation of the batteries.

1. Services battery switch
2. Enable light buttons services battery switch
3. Auxiliary battery switch
4. Services / auxiliary parallel battery switch
5. Key switch for enabling engines / services battery switch
6. Port engine battery switch
7. Enable light buttons engines battery switch
8. Starboard engine battery switch
9. Parallel battery switch starboard / port engine

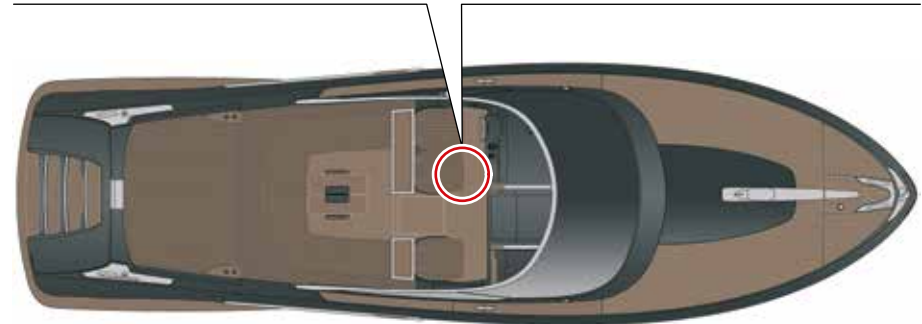
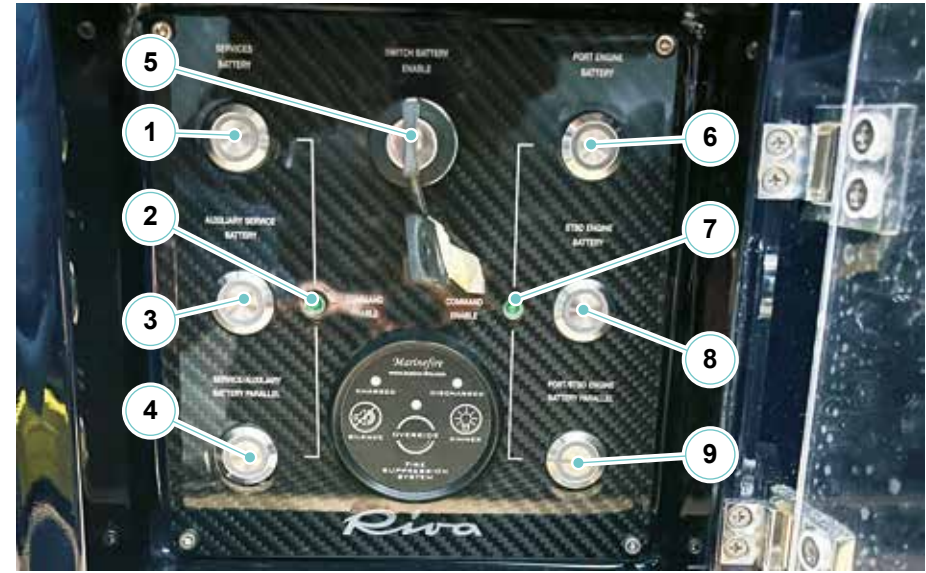

4.2 INSTRUMENTATION

4.2.1 VHF-DSC Radiotelephone

The VHF device allows communication on channels dedicated to Port Authority, rescue and radio stations.

To ask for rescue it is necessary to use the suitable **VHF/FM** channel: after each hour, as a legal rule, follow 6 minutes of silence, from minute 0 to minute 3 and from minute 30 to minute 33, so as to enable a better listening of the distress communications.

If the VHF is used, the distress call must be preceded and ended by the wording "**MAYDAY, MAYDAY, MAYDAY**".

It is therefore necessary to give your position, the yacht's name, the kind of damage and the kind of help you require (medical, mechanical, etc..).



CAUTION

Perform the "**MAYDAY**" rescue call, only in case of real need.

If, listening to the distress channel, a distress call that has not yet received an answer is picked up, it is possible to send a "**MAYDAY RELAY, MAYDAY RELAY, MAYDAY RELAY**", forwarding the communication of the person who requested rescue.

It can in fact happen that the distress call, carried out on the open sea or by means of a poorly powered sender, is not received by the rescue team. Acting as a spokesman, you can help the message reach its destination successfully.



**CAUTION**

Perform the call “**MAYDAY RELAY**” only if there is a reasonable certainty that the message has not been collected by the rescue team so as not to engage the distress channel uselessly.

The use of the standard procedure avoids creating confusion and shortens the transmission time. In case of danger, use only the phonetic alphabet recommended.

The VHF device is a vital and important communication line; please remember some fundamental rules:

- No transmission should be performed without reason;
- Listen before transmission so as to avoid interference with other senders;
- For distress calls, use and hold the best possible wireless contact;
- Always use your call identification or the name of the yacht in order to make yourself identifiable. The use of names or family names is not allowed;
- Send short and clear messages;
- For distress calls it is important to give the yacht's position, the kind of danger, the time passed in water, the kind of yacht and the number of persons involved;
- For other calls, once the contact with the person called has been established, transfer the call on an operation channel;
- Cut out transmission if required by a coastal station;
- Retune the radio when the call is ended.

To use the radiotelephone:

- Turn the ON/OFF/volume control on the top of the radio clockwise.
- The radio will enter standby mode. This is indicated by the Amber LED flashing once every 5 seconds, signalling that the radio is ready for use.
- Adjust the volume control to select the desired volume level.
- Using the channel buttons ensure that the correct channel is selected.
- When a valid signal is received, the LED will light steady green and audio will be output from the radio speaker.
- When finished using the radio, switch it OFF by turning the ON/OFF/volume control until it clicks and the radio is switched OFF.

MANUAL DISTRESS CALL:

- Select the distress channel by pressing key 16/9 or by scrolling the channels with the volume keys.
- Press the transmission key (PTT) on the radiotelephone and make the call.

MAYDAY - MAYDAY - MAYDAY THIS IS:

Repeat the yacht's name for 3 (three) times.

MAYDAY THIS IS:

Repeat the yacht's name.

AT POSITION:

Specify the position of the yacht.

SPECIFY THE DISTRESS CAUSE:

- Release the (PTT) transmission key.
- Wait for the reply for a few seconds.
- If you do not receive any reply, repeat the message at regular intervals, until receiving a reply.
- When you receive an answer, continue the conversation:
 - Hold down (PTT) while talking.
 - Release (PTT) while listening.
- It may be required to switch to a working channel.

**WARNING**

For the selection of channels and activation of the particular functions of the radiotelephone, please refer to the specific manual supplied by the manufacturer.

NOTE

For further information on use and maintenance, please refer to the manufacturer's manual.

4.2.2 Engine control levers

The engine control levers are a system designed to manage the engine revolutions and the inverter gears by means of electrical signals. With the levers to the central position, the engines turn at idle and the inverter is in neutral.

Moving the levers to the first level up engages the gear; moving the levers higher increases engine revolution, thereby increasing yacht speed.

The same procedure moving the levers downwards engages the reverse gear.

The left lever controls the port engine; the right lever controls the starboard engine.

NOTE

For further information on use and maintenance, please refer to the manufacturer's manual.

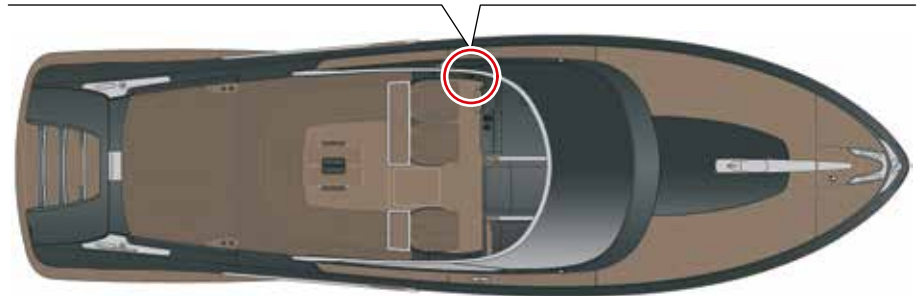

4.2.3 Steering wheel

The steering wheel is connected to a hydraulic pump which uses hydraulic drive systems (cylinders) to move the rudders.

NOTE

For further information on use and maintenance, please refer to the manufacturer's manual.

4.2.4 Chartplotter / echosounder

This instrument offers all the features of a digital echosounder and a chartplotter.

The overlapping of the chartplotter image combined with data windows defined by the user, transform the device in a true and real integrated navigation system.

By means of the remote control, all functions and controls of the various instruments are accessible, allowing safe navigation.



CAUTION

Pay the outmost attention during navigation, because in proximity of the yacht a shadow cone is formed, which is not covered.



CAUTION

The electronic chart is an aid to navigation, designed to facilitate the use of authorized government charts, not to replace them. Only official government charts and notices to crews contain all information needed for the safety of navigation and, as always, the Captain is responsible for their proper use.

NOTE

For further information on use and maintenance, please refer to the manufacturer's manual.

4.2.5 Bow thruster control panel

The bow thruster control panel consist of an activating pushbutton (ON/OFF) and of a bi-directional joystick (starboard/port).

To make the manoeuvring thruster controls operational, the relevant circuit breaker must be activated.

The mapping combined with user-defined data windows transform the instrument into a real integrated navigation system.

By remote control, you can access all the functions and commands of the various tools allowing safe navigation.

NOTE

Remember to disconnect the power supply of the system when manoeuvres are ended or during normal navigation.



DANGER

During the bow thruster operation, pay attention to possible swimmers or small yachts which may be close to the thruster tunnel. Always stop the thruster before undertaking inspection or maintenance tasks by disconnecting the switches and possibly also the battery terminals.

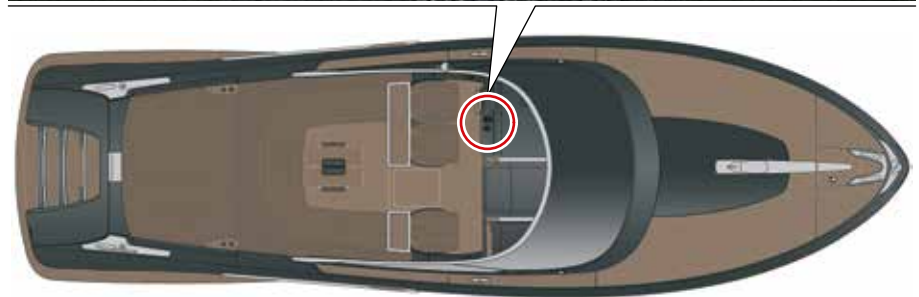

4.2.6 Magnetic compass

The magnetic compass fitted on the dashboard of a yacht of such size, is inevitably close to the magnetic fields produced by the electric and electronic systems on-board. Compass turns for compensation must be carried out by a specialized technician.

We remind you that the compensation should be carried out a couple of weeks after the launching, in order to eliminate the magnetization developed during the construction of the yacht.



CAUTION

The yacht is delivered with a compass not compensated. The compass compensation has to be carried out at Owner's responsibility, after the installation of any additional electronic equipment, and should be performed by an authorised and qualified technician. Any electrical or metallic items located in its proximity may influence the compass.

NOTE

At least once a month check the operation and the deviations. When necessary have it calibrated and compensated again.

NOTE

For further information on use and maintenance, please refer to the manufacturer's manual.

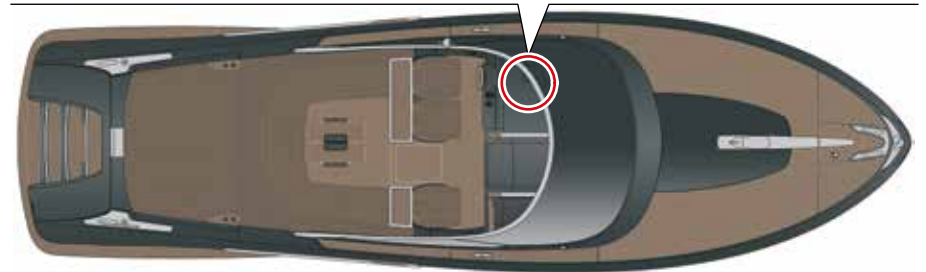



Riva

RIVAMARE CENTO

Riva

RIVAMARE CENTO

WATER SYSTEMS

CHAPTER 5

5.1 FRESH WATER SYSTEM

The water supplying your yacht's fresh water circuit is contained in a tank **(1)** with a capacity of 330 litres (87 gals), located in the aft area of technical room.

The tank is filled via a gravity filling nozzle **(2)**, located in the stern port side, near the mooring cleats.

The plug of the fresh water tank filler is linked to the structure by means of a steel cable which prevents it from getting lost or falling into the sea.

The tank is also equipped with an air vent located beside the filling plug, and with an electronic level switch that transmits the level indications to the special instrument in the helm position.

From the tank, fresh water is sucked by the autoclave pump **(3)**, located in the technical room, through a special suction pipe.

The fresh water pump, protected and supplied by the magneto-thermal switch located on the main electrical panel, guarantees the continuous presence of fresh water in the system by a check valve.

When the yacht is left unused, for long periods of inactivity or winter storage, we recommend keeping a concentrated quantity of disinfectant inside the tank, and then to drain the tank by opening all uses.

This will enable a disinfection of the whole system, preventing the formation of bacteria in the system.

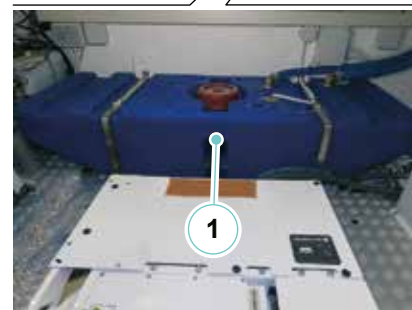
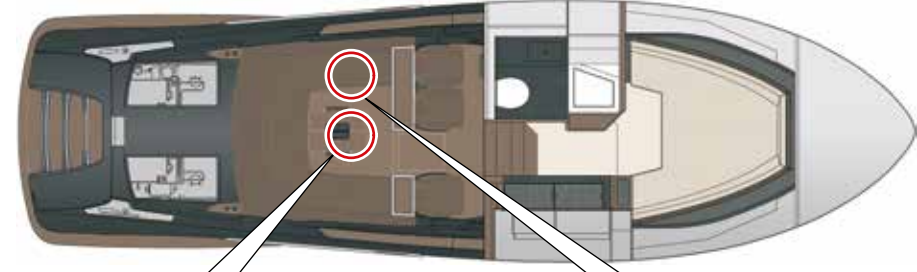

**CAUTION**

Before refilling the fresh water tank, check that the water supplied by the dock fresh water system is drinkable.

**CAUTION**

The fresh water circuit, and particularly the tanks, must be sanitized periodically by pouring in the case a specific disinfectant solution. We recommend in any case that the water coming from the on-board system not be drunk.

**CAUTION**

Regularly inspect the fresh water and bilge circuits for leaks. Repair any leaks by releasing the pressure in the system, in order to avoid damaging the furniture and the electrical equipment.

**CAUTION**

The pressure regulator at pumps output is set at the factory; do not modify.

**CAUTION**

The inlet plug is marked "WATER" to avoid accidental introduction of different liquids. To avoid damage to the system and tanks, we recommend replenishing by gravity and not by pressure.

**WARNING**

It is a good norm to optimise the use of water, especially if navigating at open sea!

NOTE

For further information on use and maintenance, please refer to the manufacturer's manual.

Fresh water system diagram

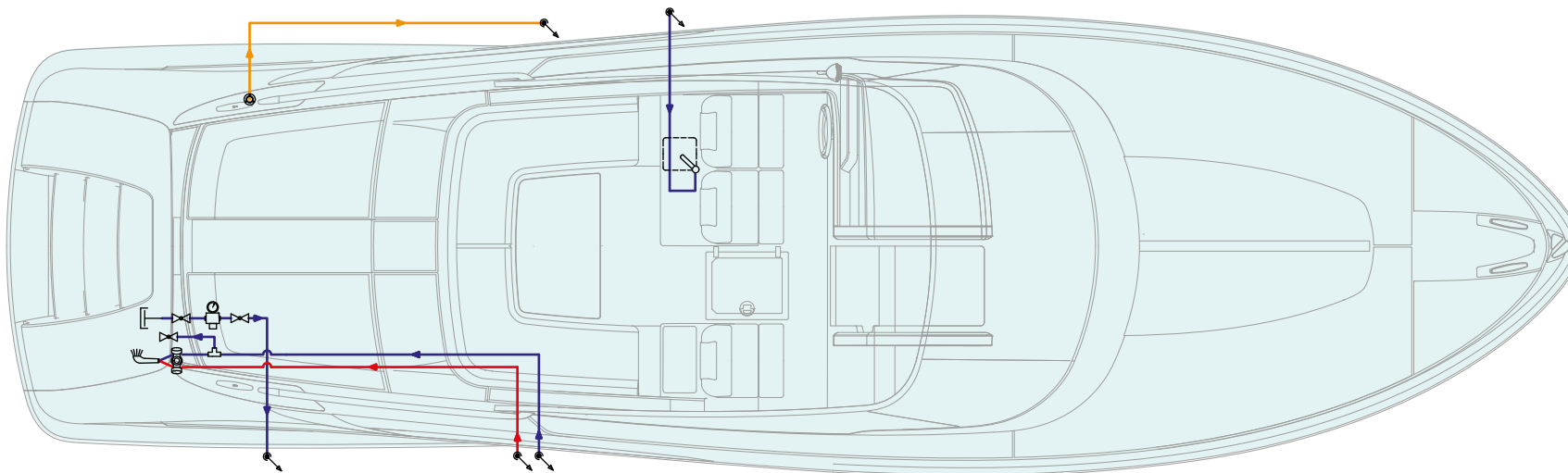

ICONA ICON	DESCRIZIONE DESCRIPTION
	Valvola a sfera Ball valve
	Elettrovalvola per tergicristalli Electro valve for wipers
	Riduttore di pressione Pressure reducing valve
	Tappo di imbarco Filling cap
	Connessione a livello superiore Connection to upper level
	Connessione a livello inferiore Connection to lower level
	Elettrovalvola Electro valve
	Valvola a sfera a tre vie Ball valve three-way

ICONA ICON	DESCRIZIONE DESCRIPTION
	Serbatoio dell'acqua dolce Fresh water tank
	Scarico centralizzato Centralized drain
	Elettropompa con pressostato di sicurezza Electro pump with security pressure switch
	Valvola di non ritorno Non-return valve
	Collettore a due vie con saracinesche Two-way manifold with gate valve
	Collettore a tre vie con saracinesche Three-way manifold with gate valve
	Scaldabagno verticale Vertical water heater

ICONA ICON	DESCRIZIONE DESCRIPTION
	Doccetta / miscelatore Stern shower / mixer
	Impianto acqua dolce fredda Cold fresh water system line
	Impianto acqua dolce calda Hot fresh water system line
	Linea acqua dolce WC WC fresh water line
	Linea di ventilazione Air vent line
	Linea riempimento acqua dolce Fresh water tank filling line
	Linea aspirazione acqua dolce Fresh water suction line

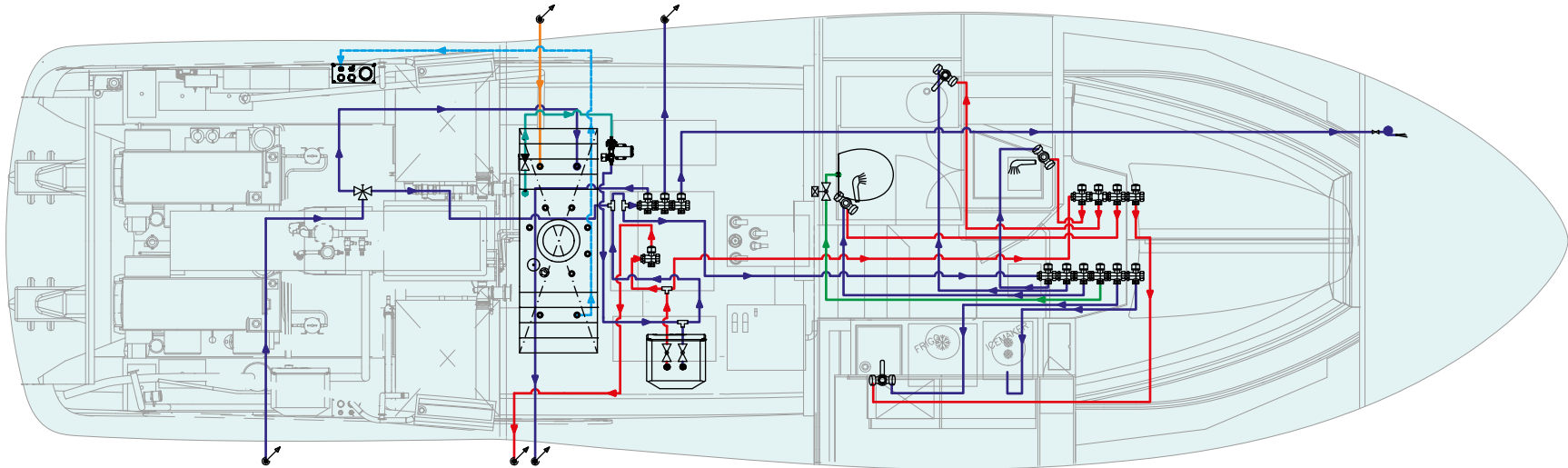

ICONA ICON	DESCRIZIONE DESCRIPTION
	Valvola a sfera Ball valve
	Elettrovalvola per tergicristalli Electro valve for wipers
	Riduttore di pressione Pressure reducing valve
	Tappo di imbarco Filling cap
	Connessione a livello superiore Connection to upper level
	Connessione a livello inferiore Connection to lower level
	Elettrovalvola Electro valve
	Valvola a sfera a tre vie Ball valve three-way

ICONA ICON	DESCRIZIONE DESCRIPTION
	Serbatoio dell'acqua dolce Fresh water tank
	Scarico centralizzato Centralized drain
	Elettropompa con pressostato di sicurezza Electro pump with security pressure switch
	Valvola di non ritorno Non-return valve
	Collettore a due vie con saracinesche Two-way manifold with gate valve
	Collettore a tre vie con saracinesche Three-way manifold with gate valve
	Scaldabagno verticale Vertical water heater

ICONA ICON	DESCRIZIONE DESCRIPTION
	Doccetta / miscelatore Stern shower / mixer
	Impianto acqua dolce fredda Cold fresh water system line
	Impianto acqua dolce calda Hot fresh water system line
	Linea acqua dolce WC WC fresh water line
	Linea di ventilazione Air vent line
	Linea riempimento acqua dolce Fresh water tank filling line
	Linea aspirazione acqua dolce Fresh water suction line

5.1.1 Cold fresh water system

The pump draws the cold water from the fresh water tank and sends it to the following uses:

- Shower on stern platform;
- Bathroom services;
- Galley;
- Water heater;
- WC system;
- Chain wash.

If the yacht is moored in a marina that includes running water service, the equipment can be supplied without using the yacht's autoclave by means of the pressure from the shore system.

The connection with shore running water occurs through the water connection located inside the peak on the starboard side of the swim platform access stair's step.

A pressure reducer, located in the engine room, protects the yacht's water system against harmful pressure variations.

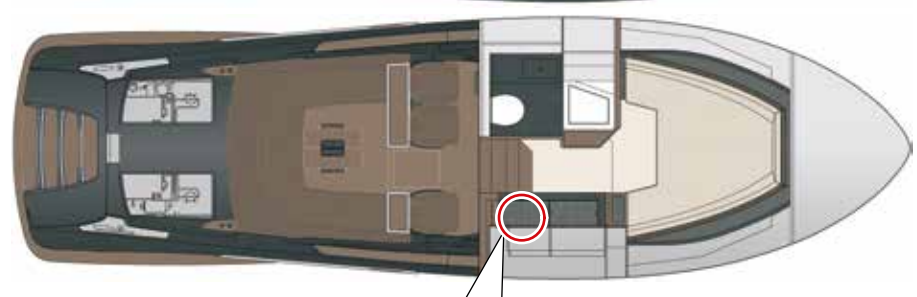
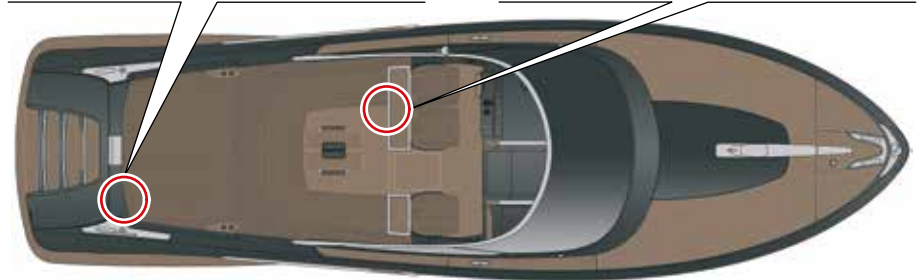
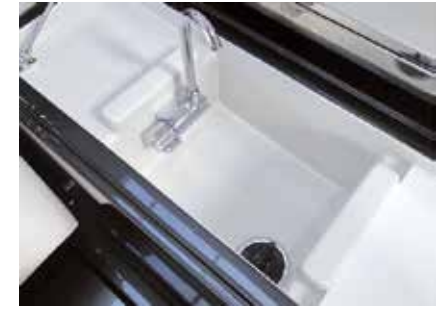

The fresh cold water reaches all utilities through the distribution manifolds, provided with check valves in order to enable the sectioning of the system in case of failure or maintenance.

The distribution manifolds are located in the lower deck dunnages.

**CAUTION**

Regularly inspect the fresh water and bilge circuits for leaks.

Repair any leaks by releasing the pressure in the system, in order to avoid damaging the furniture and the electrical equipment.

The fresh water circuit, and particularly the tank, must be sanitized periodically by pouring a specific disinfectant solution into the filler.

5.1.2 Hot fresh water system

The autoclave pump draws the cold water from the fresh water tank and sends it to the electric water heater, located on the starboard side in the technical room.

The water inside the water heater is heated and then reaches the following utilities:

- Shower on stern platform;
- Bathroom services;
- Galley.

The fresh cold water reaches all uses through the distribution manifolds, provided with check valves in order to enable the sectioning of the system in case of failure or maintenance.

The water heater is supplied at 230V delivered either by the generator or by the shore power supply; in order to activate the water heater, operate the magneto-thermal switch located on the main electrical panel.

The water heater's inlet and outlet water ducts are equipped with ball cut-OFF valves.

The inlet duct is provided with a check valve which prevents hot water back flow inside the circuit.

This valve shall be checked and replaced according to the indications given by the manufacturer.





NOTE

The water heater is not an accumulator: wait that goes up to temperature.





NOTE

For further information on use and maintenance, please refer to the manufacturer's manual.

5.1.3 Maintenance fresh water system

Component	Maintenance	Notes and precautions
Fresh water tank	Inspection and cleaning	<p>At least every month, drain the fresh water tanks completely and rinse them a couple of times with clean fresh water for change completely the water stowed in the storing tanks and at the same time to wash them too.</p> <p>Periodically pour a specific disinfectant, in the quantity recommended by the Builder, into the tanks, through the intake filler, in order to prevent the formation of bacteria in the system.</p>
Fresh water system	Inspection	<p>In case of need or of maintenance, by acting on the valves installed on the distribution manifolds, it is possible to cut out parts of the system or single utilities, without involving the operation of the general system.</p> <p>Check if along the hydraulic circuit, where possible, are present leaks due to the damage of piping.</p> <div data-bbox="1133 762 2136 991" style="border: 1px solid orange; padding: 10px; margin: 10px 0;"> <p style="text-align: center;"> WARNING</p> <p>The high temperature can cause the softening of the pipes and the following slackening of the fittings. Always check the pipes tightening, especially those located near heat sources.</p> </div> <div data-bbox="1133 1034 2136 1230" style="border: 1px solid orange; padding: 10px; margin: 10px 0;"> <p style="text-align: center;"> WARNING</p> <p>During the winter, if you do not use the yacht, it is advisable to drain all the circuits where there is fresh water to avoid cracks due to frost.</p> </div>

Component	Maintenance	Notes and precautions
Water heater	<p>Checks and cleaning</p> <p>Descaling the resistor</p> <p>Aluminium sacrificial anode</p>	<p>To obtain a good performance from the system, it is advisable to descale the resistor about every two years, according to the indications given by the Manufacturer.</p> <p>To obtain a good performance from the system, it is advisable to descale the resistor about every two years, according to the indications given by the Manufacturer.</p> <p>Replace the possible aluminium sacrificial anode every two years, according to the indications given.</p>
Autoclave pump	Inspection and cleaning	<p>The maintenance of the pump should be serviced by qualified personnel only, after having been disconnected from the power mains.</p> <p>No routine maintenance is required so long as the following precautions are taken:</p> <ul style="list-style-type: none"> • In case of freezing risk, it is necessary to empty the pump body; then refill the pump before operating it but make sure the ambient temperature is higher than the water freezing temperature. • Make sure the pump never works dry. • If the pump remains unused for a long time, it is better to empty the body and clean it. • Periodically check the efficiency of valves and filters, if any. • To Direct Current motors the brushes must be periodically checked for consumption and spring pressure. <p>Protect electric components of the pump with proper products.</p> <div style="border: 1px solid black; padding: 5px; margin-top: 10px;"> <p style="text-align: center;">NOTE</p> <p>For further information on use and maintenance, please refer to the manufacturer's manual.</p> </div>

Component	Maintenance	Notes and precautions
Autoclave pump	Inspection and cleaning	<div data-bbox="1137 268 2130 598" style="border: 1px solid orange; padding: 5px;">  <p>WARNING</p> <p>The surge tank pump is self-priming but it needs though, in order to operate, to have its body filled with liquid. For a correct use, we recommend priming first or after a long period of idling, to fill the pump body with liquid, to check the pressure inside the tank (it must have the same pressure priming the electric pump) and to verify the clockwise rotation of the pump (seen from the engine side).</p> </div> <div data-bbox="1137 644 2130 834" style="border: 1px solid orange; padding: 5px;">  <p>WARNING</p> <p>If the control panel shows the pump operating led remains always lit, but the connected utilities are not in use, check for leaks.</p> </div> <div data-bbox="1137 880 2130 1142" style="border: 1px solid orange; padding: 5px;">  <p>WARNING</p> <p>When anomalous situations occur, such as lack of water or pipes clogging, it indicates the presence of faults by means of the red light "Failure" and stops the pump. By pressing red button (reset) the system restart.</p> </div> <div data-bbox="1137 1189 2130 1366" style="border: 1px solid red; padding: 5px;">  <p>DANGER</p> <p>Before carrying out maintenance on the fresh water pump, avoid its accidental priming.</p> </div>

5.2 GREY WATER SYSTEM

The grey discharge water is collected inside the tank (1) located in the technical room.

The tank collects the discharge water from sinks and shower's bathroom; it also collects the condense water of the air conditioning system fan-coil. The tank, not being airtight, does not need any air vent.

The pump power supply magneto-thermal switch is located on the main control panel, together with a warning light that signals its operation.

The pump is automatically controlled by an electronic level switch installed inside the tank. The grey water pump (2) starts when the sensor detects a high water level and deactivates once the water level has lowered. The system is equipped with a timer which delays useless pump start ups due to yacht's roll.

The galley's basin discharges directly overboard, without any pump, through the outboard discharge located below the basin itself. The cockpit's sink and ice-maker also discharge directly overboard, on the port side.

The system is approved for navigation on Swiss lakes and is equipped with a gray water collection system also to the galley sink and the cockpit (which normally discharging directly overboard).

The system is equipped with suitable solenoid valves that interlace the taps, in case the collection box is full. The system is provided with a system that allows the suction of gray water from the platform.

The sea discharges have been plugged.

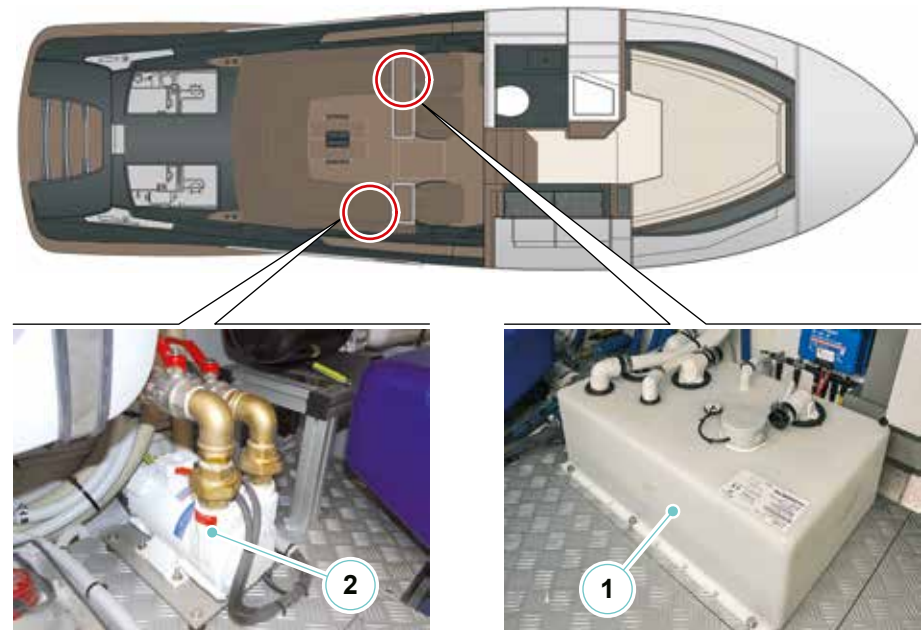



ENVIRONMENT

According to the regulations in force for navigation on Swiss lakes, grey water must be discharged exclusively by suction from the shore, through a special outlet, after activating the three way valve located in the technical room, following the instructions on the special label.

Grey water system diagram

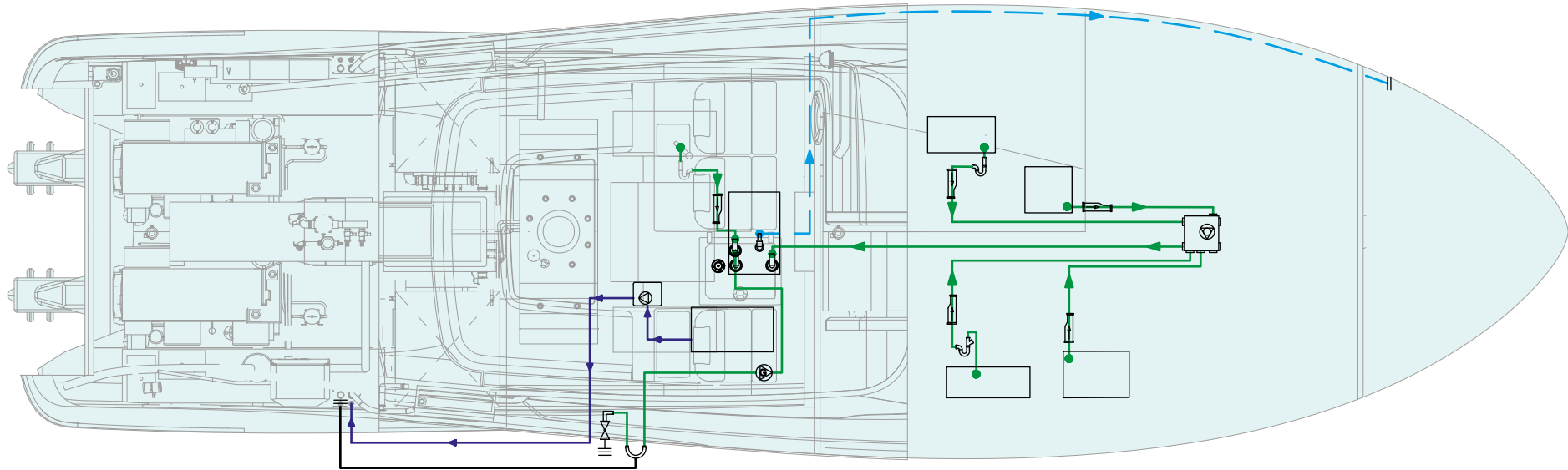

ICONA ICON	DESCRIZIONE DESCRIPTION
	Sfiato aria Air vent
	Valvola a sfera Ball valve
	Siphonbreak Siphonbreak
	Tappo scarico Drain plug
	Fan coil Fan coil

ICONA ICON	DESCRIZIONE DESCRIPTION
	Serbatoio acque grigie Grey water tank
	Scarico fuori bordo Overboard discharge
	Pompa acque grigie Grey water pump
	Vaschetta con pompa 24V e galleggiante Tank with 24V pump and float Switch for automatic emptying

ICONA ICON	DESCRIZIONE DESCRIPTION
	Sifone livello cucina Galley sink siphon
	Sifone antiodori Antiodors siphon
	Scarico fuori bordo centralizzato Centralized overboard discharge
	Sifone livello bagno Toilet sink siphon

5.2.1 Grey water system maintenance

Component	Maintenance	Notes and precautions
Grey water tank	Cleaning	<p>At least every month, drain the grey water tanks completely and rinse them a couple of times with clean fresh water.</p> <p>Periodically pour a specific disinfectant, in the quantity recommended by the Manufacturer, into the drains of sink and showers, in order to prevent the formation of bacteria in the system, and the consequent release of bad smells.</p>
Grey water draining pump	Operation check	<p>At least every month, check the status and the operation of the grey water pump, as well as its overboard drain.</p>

5.3 BLACK WATER SYSTEM

The black water system installed on board the yacht mainly consists in a black water holding tank (1) with a capacity of 38 litres (10 gals).

The black water collection tank is located in the starboard side of the technical room.

The airtight tank's air vent is located inside the chain locker.

Before being discharged overboard, the vented air flows through a special active carbon filter which eliminates bad smells.

The tank is equipped with a level switch which starts the discharge pump when it detects a high black water level, and deactivates it once the level has decreased.

The system is equipped with a timer which delays useless pump start ups due to yacht's roll.

The level switch measures the water level inside the tank and sends alarm signals to the main electrical panel and to the toilet control pushbutton panels.

The electric toilet system is supplied and protected by the magneto-thermal switch located on the main electrical panel; it must be activated in order to allow toilet operation.

Black water drain in automatic mode takes place only after the activation of the corresponding magneto-thermal switch on the main electrical panel; it is possible to drain black water manually or automatically, by pressing the selector switch on the main electrical panel.

The sea discharges have been plugged.

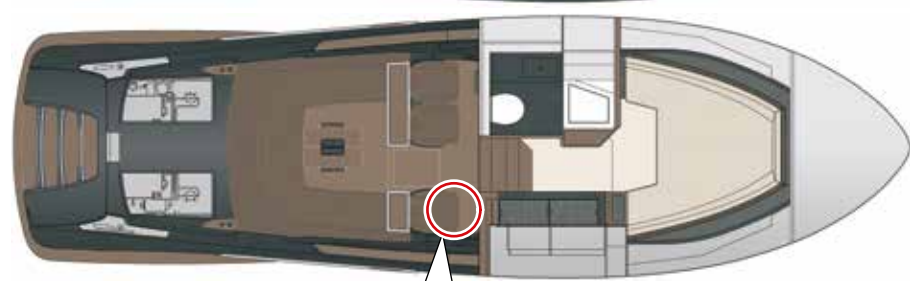
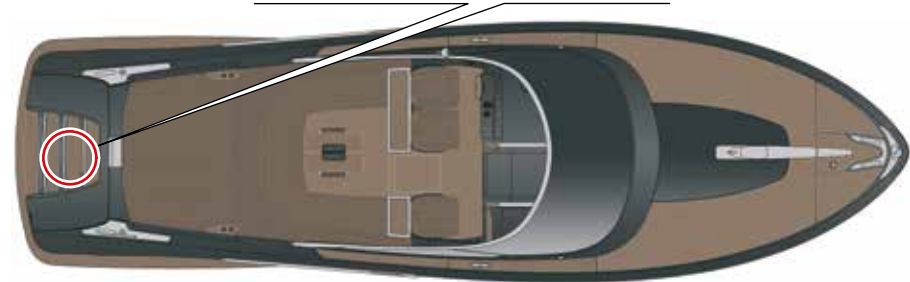

We recommend always checking the warning lights on the toilet ceiling lights and on the main electrical panel, and anyway, draining the tank before entering the harbour, to prevent being forced to return to open sea again to carry out its draining.



CAUTION

In case of yacht sinking risk, close the ball valve of the overboard drain.



ENVIRONMENT

For all pleasure yachts, drain at sea of on-board toilets is forbidden inside harbours, landings and moorings dedicated to crafts' anchor riding, and also within the limit of beaches visited by swimmers, as stated in the single decrees of the Port Authorities.



ENVIRONMENT

All pleasure yachts classified for a number of passengers exceeding the 15 units and equipped with toilets can drain the untreated sewage at sea according to MARPOL rules, only BEYOND the limit of 12 (twelve) miles from the coast, while navigating at fixed track and at the maximum speed allowed, anyway not lower than 4 knots.



ENVIRONMENT

As it is possible to automatically empty the tank, we recommend that, according to the environmental rules in force, once entered in the harbour, you set the activation of the black water pump to manual mode only. The direct overboard drain of the toilet is regulated by the rules in force in the area where the yacht is navigating. When heading for the harbour, check the tank level and, if necessary, drain the tank at open sea before entering the harbour, always carefully taking into consideration the yacht's position. Except for organic waste, only very thin toilet paper can be discharged into the sea toilets.

The black water system is equipped with a water suction system from the main deck, without using the overboard discharge pump.

Suction occurs through the special opening, located inside the aft peak allows discharging black water (2) by means of the suitable equipment available in the harbour.



CAUTION

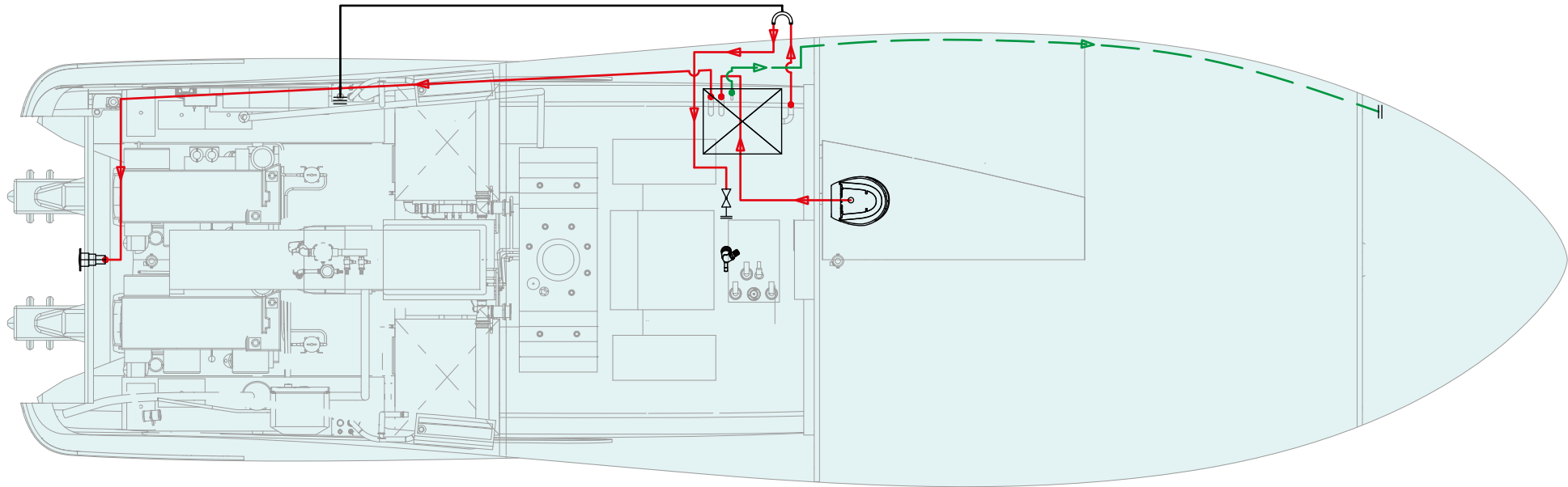

The suction outlet, located inside the aft peak, is labelled with a "WASTE" indication, in order to avoid the accidental penetration of liquids such as water or fuel.

Black water system diagram



ICONA ICON	DESCRIZIONE DESCRIPTION
⊥	Sfiato aria Air vent
⊗	Valvola a sfera Ball valve
⤿	Siphonbreak Siphonbreak
⊥	Tappo scarico Drain plug
⊥	Scarico fuori bordo Overboard discharge

5.3.1 Maintenance of black water draining system

Component	Maintenance	Notes and precautions
Black water tank	Rinse the tank (at least once a month)	<p>Fill the tank with clean water and empty it two or three times. It is advisable to periodically pour a sterilizing product into the toilet drain in order to prevent the formation of bacteria and associated unpleasant odours.</p> <div data-bbox="1137 469 2132 660" style="border: 1px solid yellow; padding: 5px;"> <p style="text-align: center;"> CAUTION</p> <p>Should deodorants or disinfectants be used, avoid abrasive substances or acids, because they could damage tubes and seals.</p> </div> <div data-bbox="1137 705 2132 896" style="border: 1px solid yellow; padding: 5px;"> <p style="text-align: center;"> CAUTION</p> <p>In case of need, break or pollution of the tanks, they can be replaced. Contact the RIVA After Sales & Service Department.</p> </div> <div data-bbox="1137 941 2132 1313" style="border: 1px solid gray; padding: 5px;"> <p style="text-align: center;">MAINTENANCE</p> <p>At least once a week check the correct operation of the:</p> <ul style="list-style-type: none"> • Toilet; • Waste water pump. <p>At least once every 3 months check the condition of the pipes and fittings.</p> <p>At least once every 6 months treat with special protective products:</p> <ul style="list-style-type: none"> • The toilet solenoid valves; • The waste water pump. <p>Thoroughly clean the waste water tank when necessary and at least once a year.</p> </div>

Component	Maintenance	Notes and precautions
Pump	Replacement of impeller and mechanical seal	<p>This is a complex operation and should only be undertaken by skilled personnel.</p> <div style="border: 2px solid yellow; padding: 10px; margin: 10px 0;">  <p>CAUTION</p> <p>The electric motor may be hot during operation. Pay attention. The electric pump must only be repaired by competent or qualified personnel, using manufacturer's spares; if this procedure is not followed, the manufacturer is relieved of any responsibility and warranty is void and null.</p> </div>

Component	Maintenance	Notes and precautions
Pump	Operation check and cleaning (at least every month)	<p>Electric pumps usually do not need ordinary maintenance, as long as some precautions are taken, which extend their lives (address to the pumps' Manufacturer).</p> <div style="border: 2px solid red; padding: 10px; text-align: center;">  <p>DANGER</p> <p>Before each intervention make sure that voltage is disconnected and that there is no possibility of accidental connection.</p> </div> <ul style="list-style-type: none"> • If there is a risk of freezing, it is necessary to empty the pump casing from the liquid and to fill it, before restarting the pump. • Make sure that the pump never runs dry. • The DC motor brushes must be periodically checked for consumption and spring pressure. • If the pump does not work for a long time, it is better to empty the pump casing and clean it. • If a filter and a foot valve are installed, check periodically for their efficiency and cleaning. • Check that the impeller is jammed, this could cause heavy damages to the electric motor; if this happens, descale the impeller and pump body. • At least once a month, have the operation of the grey/black water pumps checked, having their tanks filled with clean water until the pump activates and having the correct overboard draining checked.
Solenoid valve for WC drain	Filter	Just before each solenoid valve there is an extractable filter, which retains impurities and must be cleaned at least once a month.

5.3.2 WC operation

Moving your hand toward the wall switch, you will activate the usage indication: the touch panel will suggest you which button you should use blinking the relative icon.

This important innovative solution combine absolutely for the first time the advantage to have a two switches operating toilet and a very simple use for the guest, together with a very clean and elegant design.

Cleaning mode (temporary lock-out)

In order to avoid the accidental activation of the toilet while cleaning the glass, it's possible to temporarily deactivate the TOUCH panel.

- Touch and keep one of the buttons for 5 sec.
- All the backlight will be turned OFF for 30 sec.
- After 30 sec. the touch panel's lights will turn ON and will be operative.

Night courtesy light

The touch panel includes a night courtesy light.

Thanks to this feature, you can have a gentle blue illumination in the bathroom sufficient to avoid to turn ON the main light, that could be perceived as an interruption of the natural sleeping phase.

This function could be disabled, enabled permanently or in dynamic mode.

SETTING OF THE COURTESY LIGHT:

Permanent activation of the night courtesy light

In addition to the icons, the border of the panel could be permanently illuminated as night courtesy light.

To turn the night light ON or OFF, press and hold one of the buttons:

- After 5 sec. the panel is switched OFF. Keep touching.
- After additional 5 sec. the border backlight will flash and the new setting is recorded.



NOTE

If the Touch panel is not used for 10 hours, the border backlight will be turned OFF until next use (only if it has been set ON).

Dynamic activation of the night courtesy light

The night light can be switched on temporarily, only when necessary. When this function is active, the border backlight will remain normally OFF. Moving your hand over the panel, the night courtesy light will be activated for 2 minutes.

To activate or deactivate this function, press and hold on the buttons:

- After 5 sec. all the backlight will be turned OFF. Keep touching.
- After additional 5 sec. the border backlight will flash. Keep touching.
- After additional 20 sec. the border backlight will flash and the new setting is recorded.

**CAUTION**

We suggest not to use the residential function of the toilet, as the water inside the toilet could splash out and wet the floor due to the yacht's rolling.

**CAUTION**

Except for organic waste, only very thin toilet paper can be discharged into the sea toilets. Paper towels or napkins and sanitary towels can clog and damage the sanitary system.

**CAUTION**

Make sure that toilet are electrically powered and that the black water system is operating before using them.

NOTE

Forcing the toilet flush can cause the tank's overflowing.

NOTE

A full tank condition is indicated by the tank icon's red light. Draining the toilet can cause the tank's overflowing.

NOTE

The disabling of WC protection can cause the tank's overflowing.

**CAUTION**

The toilet outboard discharge valve must be closed when the yacht is not in use for long periods of time.

NOTE

For further information on use and maintenance, please refer to the manufacturer's manual.

5.4 SCUPPERS SYSTEM

The scupper system, by means of appropriate holes and drains, allows the quick off board flow of rain water, marine water or of other nature water, that may fall on main deck or on the sun-deck.

All waters collected by the scuppers are conveyed by means of manifold tubes, placed along the bulwarks.

The total or partial clogging of one or of more scuppers must absolutely be prevented, because it is a cause of flooding and consequent loss of stability by the yacht and its structures.



CAUTION

Always check the correct water flow towards the scuppers.
The partial or total clogging of one or more scuppers is a possible cause of damage for the yacht structure and of loss of stability.



CAUTION

Avoid that incorrectly stowed objects clog the scuppers.

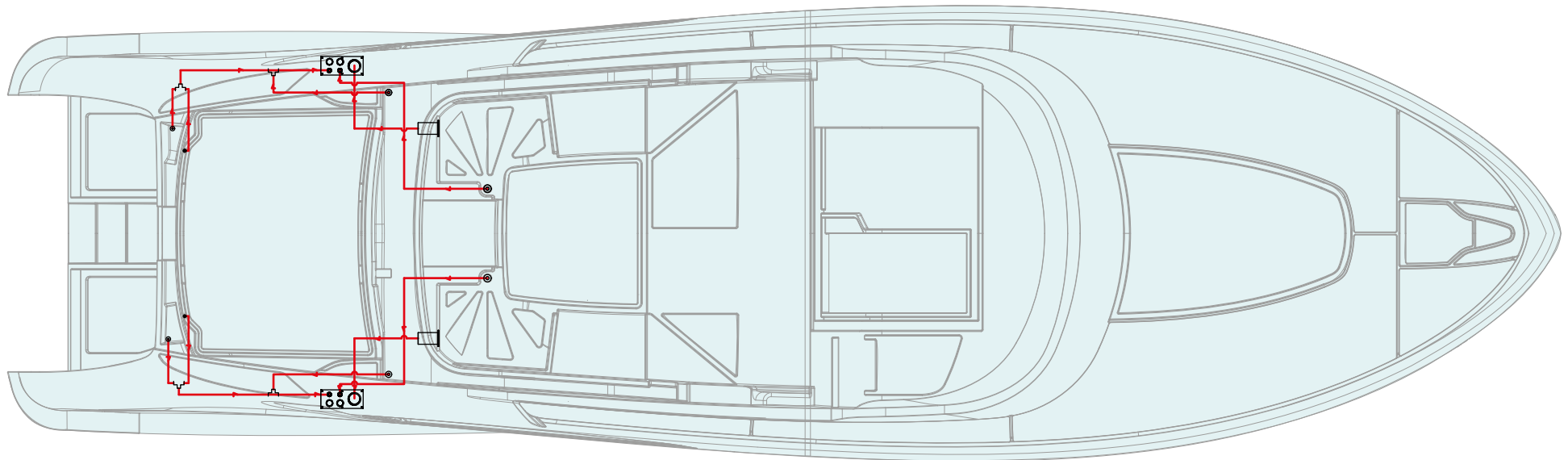

5.5 BILGE SYSTEM

The bilge suction system, manufactured according to ISO 15083 regulations, consists of three 12V diving electropumps, installed in a suitable position for the proper draining of bilges, located as follows:

- **Engine room (n°1)**
- **Technical room (n°1)**
- **Mid yacht (n°1)**

The suctions of the pumps are equipped with plastic net strainers, whose purpose is to prevent the penetration inside the circuit of foreign bodies, which may damage the pump or cause pipe clogging.

The water sucked from the bilges is sent to the overboard drains located on the yacht's sides. The diving pumps are directly connected to a battery, and thus guarantee bilge drain at any time.

Therefore, it is not necessary to activate the services battery breaker. In order to make them work, it is necessary to activate the relevant magneto-thermals located on the secondary electrical panel in the technical room.

It is possible to evacuate water from the bilges where the pumps are located either in automatic or manual mode.

The pumps' activation, in automatic mode, is controlled by floater switches (1) installed in the bilge, which activate the pumps when they detect a too high level of waters. In order to manually start the pumps, press the relevant spring push-buttons located on the helm position, making sure that the magneto-thermal switches are connected.

The upper floats (2), in the bow and stern areas of the engine room, control the activation of the "Acquallarm" alarm siren which, in the event of flooding, signals a high water level in the bilge.

The submersible bilge pumps are connected directly to the service batteries and can be operated also when the battery breaker is set to OFF, thus ensuring water evacuation even when the yacht is unattended, with the circuit breakers in the electrical panel switched ON.

The bilge high water level alarm siren, located in the helm position, is directly connected to the service batteries: therefore, for its operation, it is necessary to activate the special magneto-thermal switch located on the technical room electrical panel.



CAUTION

The system total capacity is not designed for yacht draining in case of leaks.

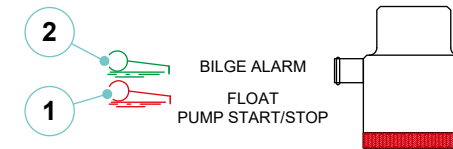

CAUTION

In case of leaks in the engine room, it is possible to suck huge quantities of water from the engine room bilge through the cooling system pumps of each engine.

**ENVIRONMENT**

Any oil or fuel in the bilge must be collected and stowed.
It is forbidden to discharge bilge water mixed with oil or fuel into the sea, because this causes serious pollution.
During maintenance operations in the engine room, it is compulsory to disconnect the magneto-thermal switches of the bilge pumps' automatic suction system, thus preventing the accidental spillage of liquids and, consequently, sea water pollution.

1. Selection area intake manifold
2. Manual bilge pump
3. Manual bilge pump actuation bar

**CAUTION**

Avoid leaving rags or other residues which could clog the suction inlets of the pumps, thus causing serious damage to them, even though the inlets are protected by filtering nets.

**CAUTION**

Check all bilge pump operation at regular intervals. Clean the pump intakes. The hull valves installed in the bow and stern peak walls must be held closed; they must be open only to drain the water from the main bilge.

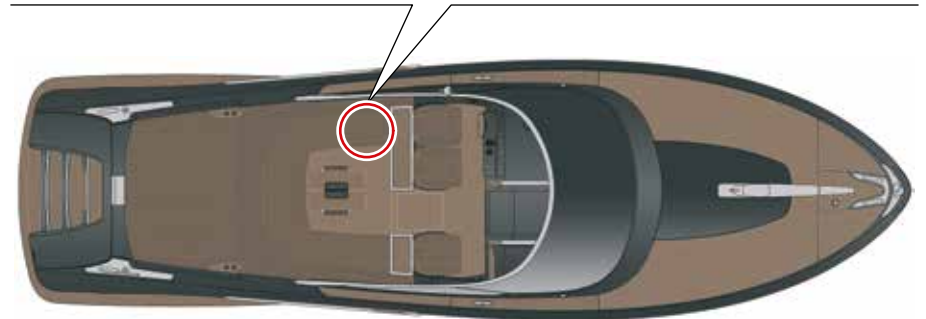
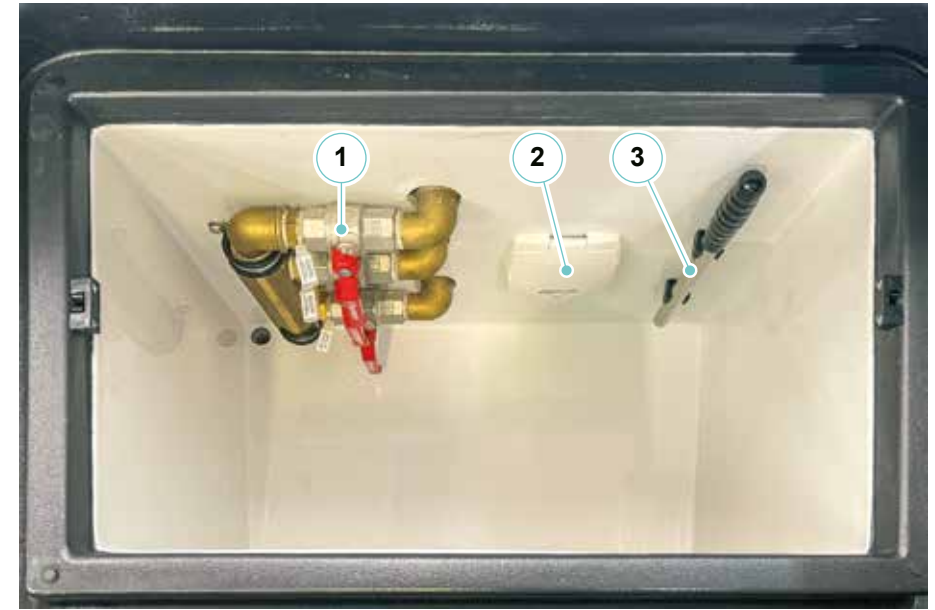

In case of malfunction of the automatic bilge pumps you can use the manual pump.

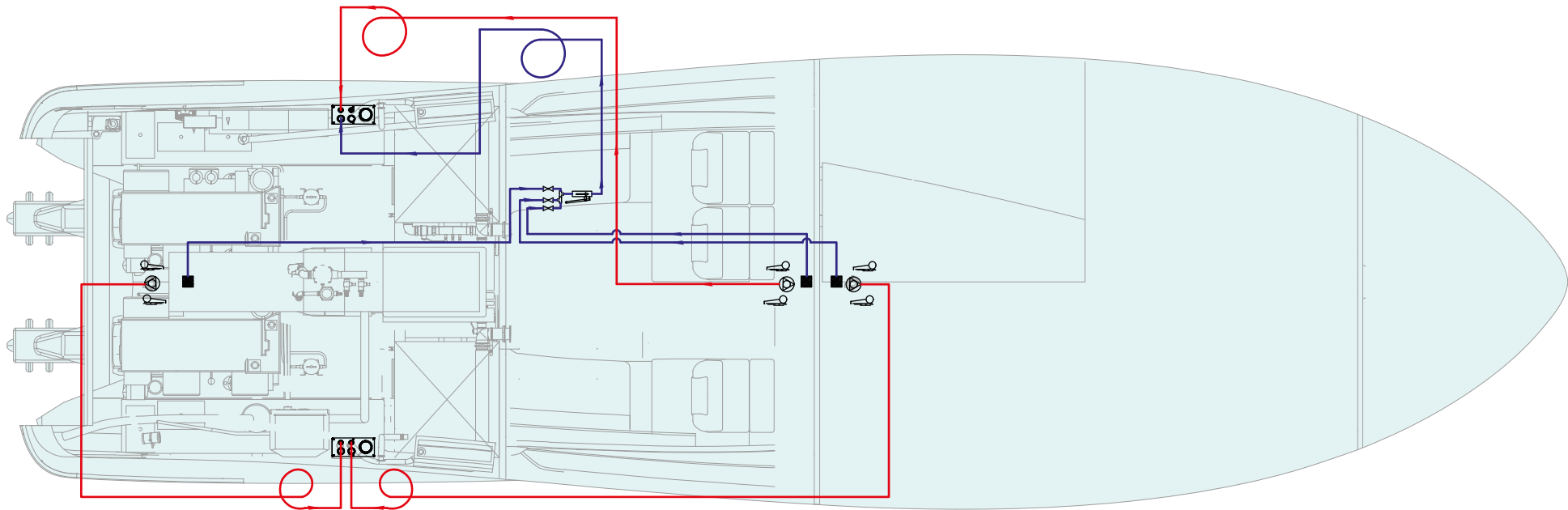

Bilge draining system diagram



ICONA ICON	DESCRIZIONE DESCRIPTION
	Pompa sentina 12V Bilge pump - 12V
	Interruttore galleggiante Float switch
	Pompa manuale Manual pump

ICONA ICON	DESCRIZIONE DESCRIPTION
	Succhieruola di sentina Bilge strainer
	Scarico centralizzato Centralized discharge
	Valvola a sfera Ball valve

5.5.1 Maintenance of bilge automatic suction system

Component	Maintenance	Notes and precautions
Bilge pumps	Operation check	<p>Check for the correct operation of the bilge pumps before each navigation.</p> <p>At least every month, check the status and the function of all installed bilge pumps as well as of the related overboard discharge.</p> <p>Pay special attention to not leave any rags or other residue in the bilge, as these may plug the pump intakes, damaging them.</p>
Bilge	Inspection and cleaning	<p>When using detergents or solvents, remember to adequately ventilate the spaces.</p> <p>Protect breathing and the eyes by using a suitable mask, and protect your hands with gloves, when using detergents.</p>
Autoclave pump	Cleaning	<p>Check the cleanliness of the pump suction protection grids.</p>

Bilge pump operation check:

This kind of electric pump does not usually need ordinary maintenance, as long as some precautions are taken to extend their good operation.

- Where a freezing danger exists, it is necessary to completely drain the bilge.
- Although the immersion pumps are designed to also work dry, it is advisable to run them under this condition as little as possible.
- Regularly check the efficiency and cleanliness of the different protection strainers.
- If the yacht is to be inoperative for a long period, it is advisable to drain the pump body and clean it.
- Check if the impeller is jammed, this should never occur because it could cause heavy damage to the electric engine; if necessary carry out impeller and pump body descaling by means of proper detergents.



DANGER

Before carrying out any maintenance operation, disconnect the magneto-thermal switches in the engine room so that accidental activation is prevented.



CAUTION

Once the checks on the bilge pumps have been completed, check that the relevant magneto-thermal switches are active again.

The operations to check the functionality of the bilge pumps are as follows:

- Check the operation of each bilge pump at least once a month, filling the bilge with clean water up to the activation of each pump and checking proper overboard pumping;
- Check the operation of each bilge pump: in manual mode, by means of the relevant push-buttons located on the synoptic panel of the main electrical panel in the helm position, or from the secondary electrical panel in the engine room; In automatic mode, by manually lifting the float switches.

**CAUTION**

Pump and component replacement must be carried out by specialized personnel, using only spare parts.

**ENVIRONMENT**

The float switches activating the bilge pumps and the alarm siren for “High water level in the bilge” contain mercury, a substance which may cause pollution. Dispose of pursuant to the laws in force.

**CAUTION**

Replacement of the pump and its components must be carried out by specialised personnel using only original spare parts.

NOTE

For further information on use and maintenance, please refer to the manufacturer’s manual.

5.6 SEAWATER SYSTEMS

Sea water directly sucked by the inner centrifugal pumps of the engines is used for engine cooling. These pumps, by means of their heat exchangers, cool down fresh water in the internal cooling circuit by absorbing transported heat.

The sea water for cooling the engine, enters through the aft foot. Many waters (harbours, rivers, coastal) contain sand and suspended matter.

In order to avoid the clogging of the heat exchanger and the intercooler, and to increase the durability of the engine cooling pump, each outlet to the sea is equipped with strainer for the external water and with shut-off for maintenance valve. Before entering into the heat exchanger, the cooling water passes through the intercooler to the charge air cooler.

The cooling sea water drawn in by the engine is sent subsequently to the inverters, for lubricant oil cooling.

The sea water for cooling the generator, the air conditioning unit and the interceptor, enters through the water intake placed on the bottom of the hull and protected by the grids.

The cooling water that is injected inside the ducts the exhaust is discharged overboard through the latter route.

The cooling water that is sent to inverters, once the lubricating oil heat absorbed, is conveyed in the exhaust of engines.

There is the possibility, in case of emergency or necessity, of removing large masses of water, if present in the bilge of the engine room, using the aspirations of the engine cooling circuit. For this operation, refer to “Intake emergency engines from the bilge”.

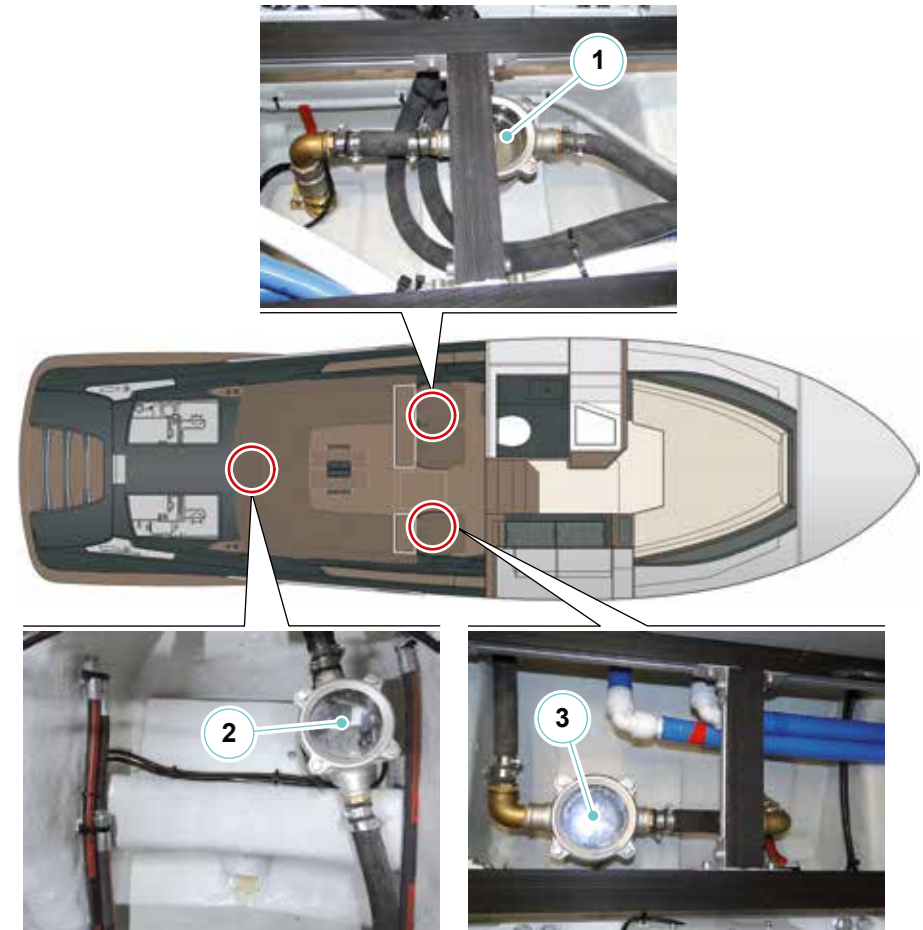

**CAUTION**

Before opening the sea cock strainer for cleaning, remember to close the cut-OFF valve in the hull.

If the yacht is not used, close as a precaution, all cut-OFF valves of the sea cocks; as soon as the yacht is reused, remember to open them.

**CAUTION**

Before cleaning the seacock filters, check that any utilities supplied with seawater are switched OFF and not in use.





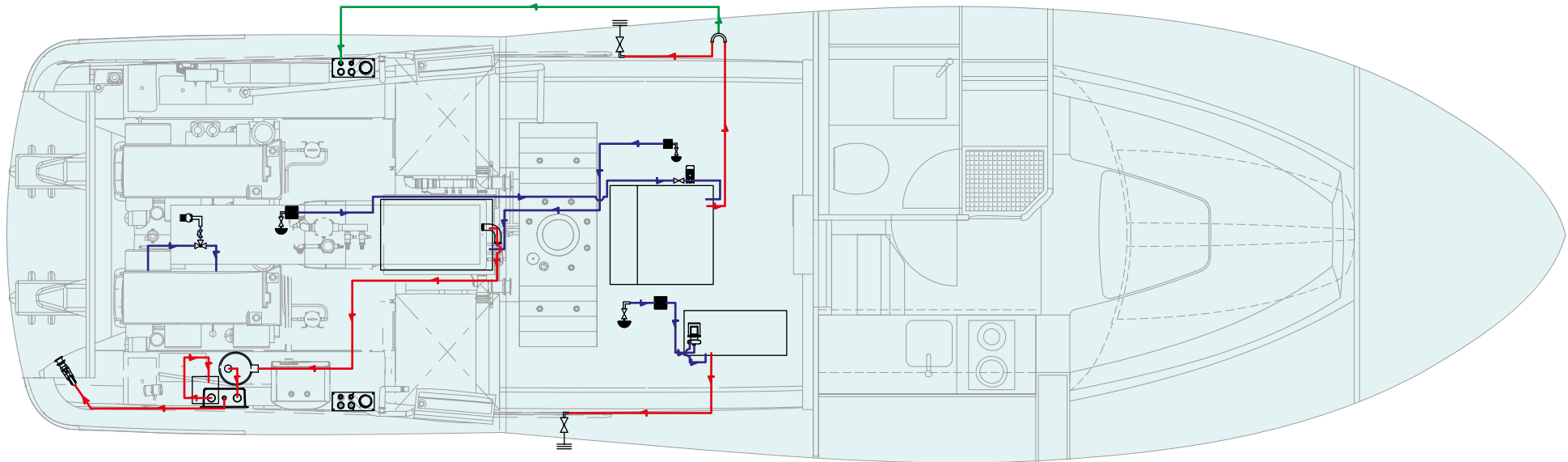

1. Generator sea cock
2. Gyroscopic stabilizer sea cock
3. Air conditioning unit sea cock

Sea water distribution system diagram



ICONA ICON	DESCRIZIONE DESCRIPTION
	Silenziatore generatore Generator muffler
	Pompa raffreddamento A/C A/C cooling pump
	Filtro Filter
	Pres a mare Sea cock
	Scarico centralizzato Centralised discharge
	Valvola a sfera Ball valve

ICONA ICON	DESCRIZIONE DESCRIPTION
	Siphonbreak Siphonbreak
	Valvola di non ritorno Non-return valve
	Scarico fuoribordo Overboard discharge
	Pompa Stabilizzatore Giroscopico Gyroscopic stabilizer pump
	Valvola 3 vie 3-way valve
	Gomito Elbow

ICONA ICON	DESCRIZIONE DESCRIPTION
	Raccordo a "T" "T" fitting
	Valvola di fondo Foot valve
	Separatore di fumi Smoke separator
	Impianto acqua mare aspirazione Sea water suction line
	Impianto acqua mare scarico Sea water discharge line
	Linea sfiato siphonbreak Siphon break vent line

5.6.1 Maintenance of sea cocks and strainers

Component	Maintenance	Notes and precautions
Seacocks and strainers	Cleaning (as required depending on the docking area, but at least every month)	<p>This operation has to be carried out outside, therefore the yacht must be in a dry dock or you can ask the intervention of a diver.</p> <ul style="list-style-type: none"> • Have the sea cocks cleaned (removal of seaweed or barnacles. If necessary have them removed with a brush). <p>Inspection and cleaning valves and filters:</p> <ul style="list-style-type: none"> • Cleaning is to be carried out more frequently if the water drawn in is particularly dirty (seaweed, mucilage, etc..). <div style="border: 2px solid orange; padding: 10px; margin-top: 10px;"> <p style="text-align: center;"> WARNING</p> <p>Before removing the filter, it is necessary to close the valve fitted to the sea cock, to prevent flooding the bilge with water.</p> </div>

Component	Maintenance	Notes and precautions
Seacocks and strainers	Cleaning (as required depending on the docking area, but at least every month)	Inspection and cleaning valves and filters: <ul style="list-style-type: none"> • Check for barnacles or corrosion on the control levers of the cut-off valves of the filter to be checked. • Clean the control levers of the valves with a brush. • Move the levers repeatedly. • Close the cut-off valve upstream the strainer. • Remove the filter cover by loosening the screws. • Remove the filter element, clean it with a brush and rinse it in water (replace as necessary). • Clean the strainer housing. • Check and, if necessary, replace the gasket of the strainer cover. • Fill the strainer with water to avoid the pumps running dry or that the system does not prime. • Reposition the strainer, the cover and tighten the nuts. • Reopen the cut-OFF valve and check whether the strainer cover is leaking.



WARNING

Before servicing the sea water lines, disable the operation of the connected utilities.
 Before restarting the utilities, make sure that the cut-OFF valve is completely open.



WARNING

During navigation, periodically check the cleanliness of the seawater filters.
 If the yacht is crossing a dirty sea area, check the condition of the strainers and proceed with their cleaning.
 Taking suitable precautions is very important to prevent damage to mechanical parts (engines, etc..), discharge systems and to not jeopardize the safety of the yacht.

Riva

RIVAMARE CENTO

ELECTRIC SYSTEM

CHAPTER 6

6.1 ELECTRIC SYSTEM

The electric system of the yacht has been designed paying the utmost attention to all aspects regarding your SAFETY and the SAFETY of your Guests and it has been manufactured using high-quality materials, fully in compliance with the rules in force.

The electric system of your yacht consists of two sections.

- Service mains supplied by a nominal current of 12V D.C.
- Service mains 230V / 50 Hz supplied from shore, or alternatively, by the power generator installed on the yacht. The generator set is supplied by a set of 12V accumulators.

The DC (12V) systems are powered by three sets of storage batteries that provide power to the engines, electrical panels, generator and bow thruster. The AC system can be supplied by the shore power system or by the on-board generator.

All the electrical services are protected by circuit breaker switches (single pole and double pole for 12V, double pole for 230V) and a ground-fault circuit breaker/switch with a sensitivity of 0,03A that protects the entire 230V AC system against accidental short-circuit contacts.

The yacht is equipped with electronic injection engines and electronic remote control systems. For this reason it is very important for the user to carry out some simple operation to prevent faults to the electric systems, which on their turn may cause problems to the propulsion system.



DANGER

The engines checking systems: accelerator and gears engagement remote controls are electronic. Their reliability is very high, but in case of a sudden black-out, it is necessary to immediately switch off the engines which is not controllable any more, by means of the relevant buttons located in the main helm position.



CAUTION

Before undertaking any navigation, check that the batteries are in good condition and that they supply the correct nominal current.



CAUTION

During navigation, the service battery and engine batteries must always be kept connected. The parallel switch on the two banks must normally be disconnected and then turned OFF.



CAUTION

If there is a malfunction of the charging alternator during navigation, turn the parallel switch between the battery banks to ON and leave it on for the shortest possible time.

**CAUTION**

Do not embark on navigation unless the engine battery switch and that of the service battery switch are both engaged and do not disengage during navigation.

**CAUTION**

Disconnect the dock power supply connections when the system is not in use.

**DANGER**

Risk of electric shock from leakage currents.
Do not swim in harbour or marine waters.

**CAUTION**

Use electric devices with double isolation or grounding.

**CAUTION**

If there is a significant and persistent drop in the voltage of one or both battery banks during navigation, check the charging efficiency of the relevant alternator.

**CAUTION**

When the engines are switched ON, the engine and service charger is automatically switched OFF to prevent them from working in parallel with the engine charging alternator.

**CAUTION**

The engine control systems: accelerator and gears engagement remote controls are electronic. Their reliability is very high, but in case of a sudden black-out, it is necessary to immediately switch OFF the engine which is not controllable any more by means of the relevant buttons located in the helm position.

**WARNING**

Do not allow the end of the shore power cord to float in the water. This may create an electric field that can cause injury or death to swimmers in the vicinity.

**CAUTION**

Do not modify the shore power cable connectors; use only compatible connectors.

The on board electrical system has been designed and installed in compliance with UNI EN ISO and RINA standards, applying the following criteria:

- All wiring, joints and line-feed protection devices such as magneto thermal breakers, RCCBs and fuses have been collected and grouped both within and on the front plates of the various on board electrical panels.
- All power lines are oversized, ducted and/or inspectable and made with flame-retardant cables laid inside special self-extinguishing sheaths; all the aforementioned lines are connected with special spring-loaded terminal blocks.
- The system is highly fragmented into sub-circuits and protected with magneto thermal breakers and fuses for each single load or homogeneous load groups in order to simplify the tracing of possible faults which, for any line, can only occur at the load and the electrical panel.

The protection of the single electric system sections is performed by automatic magneto-thermal breakers of different amperage and size, according to the absorption of the various services to be protected and by the size of cables used for their supply.

All metallic wet pieces are interlocked with equipotential connections and linked on sacrificial anodes installed on the underwater quick-work.



WARNING

Refrain from performing any modification or intervention on the system and on the panel and take advantage of experienced Companies and skilled staff. Avoid any derivations on the power lines and the addition of utilities not provided on the panel itself. If you need to assign services to the switches available, make sure that their characteristics are suitable with the device installed.



CAUTION

The parallel connection system between the batteries sets, driven by a button located in the main helm position, is used to increase the boosting power at engines start, under particularly climate conditions or charge condition, and for a short period of time.

This system must be activated only if the rocker switches connecting the engine and service battery banks are positioned to ON.

Do not use in case of faults on the batteries recharging circuits, for instance on the engines alternators. We advise to use this system only in emergency cases.



WARNING

NEVER:

- Work on the electric system while under voltage.
- Modify the electric systems of the system or relevant drawings: the installation, the modifications and the maintenance must be carried out only by a skilled marine electrician.
- Alter or modify the intensity of rated current of protections against overcurrent.
- Install or replace electric equipment or devices with components exceeding the rated current intensity of the circuit.
- Leave the yacht unattended with the electrical system powered, except for the circuits of the bilge automatic suction pumps, of the fire-fighting protection and of the alarms (directed to battery).

**DANGER**

Electrocution hazard! Turn the power OFF before removing the cover and servicing any electrical equipment internal component.

**DANGER**

We recommend, in order to operate in complete safety, to carefully read the safety rules relevant to the maintenance and contained in this manual.

**DANGER**

All electrical systems (included those at low voltage) if wrongly handled or subjected to overloads, can originate short-circuits and dangerous overheating with potential fire hazards!

**DANGER**

Before working on the charger, disconnect the shore power supply.

**DANGER**

Use the switch for the engines battery set parallel connection, only if strictly necessary for additional supply of the batteries at engine start. If you are compelled to use the “battery parallel connection”, turn OFF all electric devices so as not to jeopardize their correct operation. Disconnect them as soon as possible.

**DANGER**

Fire danger: it is normal that the transformer generates and gives out a lot of heat. Please be careful not to surround the transformer with any storage material and keep it free from obstructions to ensure that the transformer has adequate ventilation at all times. Do not stow flammable material close to the transformer.

**CAUTION**

If you are compelled to use the “battery parallel connection”, turn OFF all electronic devices, so as not to jeopardize their correct operation. In emergency conditions, use the battery parallel set for the shortest reasonable time.

**CAUTION**

RIVA suggest to examine very carefully the whole documentation delivered by the manufacturers of the various components; and for any problem relevant to maintenance, to contact RIVA After Sales & Service Department directly.

**DANGER**

The system is similar to a domestic system in terms of features and risks and, if “wrongly” used, mishandled or serviced, it statistically represents one of the most frequent reasons for fire on board.

**DANGER**

Have the internal status of the charger checked by specialised personnel at least once. Faults like loose connections, burnt wires, etc., with following risk of fire spreading, must be repaired immediately.

**WARNING**

Do not disconnect the battery master buttons with engines running or you may damage the engine alternators.

**CAUTION**

For the correct procedures of fuses replacement refer to the on-board electric manual delivered separately.

NOTE**Systems and electric circuits**

For the diagrams and the features of the electric system parts, please refer to the specific manual.

6.1.1 Maintenance of the electric system

Component	Maintenance	Notes and precautions
Equipment and circuits	Cleaning and check	At least once every six months, have the various connections of electric boards, panels and boxes checked by experienced personnel. Make sure that ground connections of electric equipment and electrical panels are tight and not oxidized. Have the absorption of the different electric motors periodically checked by skilled personnel. Check the status of the protection anodes and replace if necessary.

MAINTENANCE

At least once a week check the operation of all electrical panels.
At least once every six months:

- Check the possible presence of damaged cables;
- Protect the various contacts.



DANGER

Electric shock hazard exists in an energized electrical system. To avoid electric shock that can cause serious injury or death, turn OFF power before opening the cover and servicing any internal components of electrical equipment.



DANGER

Do not modify the electric systems or relevant drawings. The installation, the modifications or the maintenance must be carried out only by a skilled naval electrician. Inspect the system at least once a year.



CAUTION

Only a skilled naval technician can perform maintenance on the yacht's electric system.



DANGER

Before carrying out any work on the electrical system, disconnect all circuits.



CAUTION

It is forbidden to use pressurized water on light appliances installed outside.

6.2 ELECTRICAL PANELS



CAUTION

Before removing the front panel for maintenance, disconnect the shore connection.

NOTE

For a detailed description refer to the electric installation manual.

MAIN ELECTRICAL PANEL

The electrical system is controlled from the electrical panel located on the stairs leading to the cabin.

The closure of the contact of the black water pump is inhibited through a lead seal. There is no possibility to discharge black water overboard.

The following main sections have been identified, in order to make the descriptions easier:

1. Battery amperometers and voltmeters, alarm indicators and black water controls.
2. 230V line amperometers and voltmeters, generator control and power selector switch.
3. 12V uses.
4. 230V uses.



CAUTION

Always keep the safety systems powered.
Operate the battery disconnect switch for safety systems only in the event of a short circuit or an emergency.

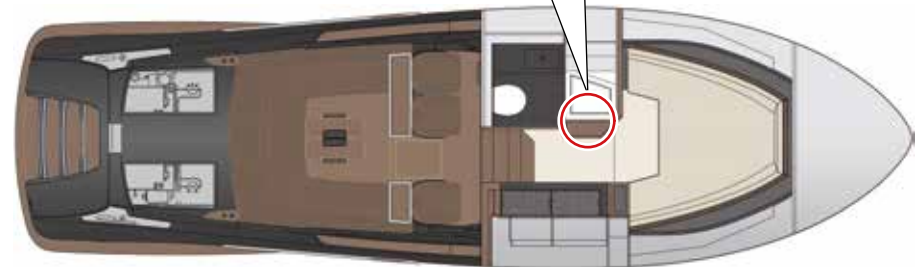

1. Battery amperometers and voltmeters, alarm indicators and black water controls



2 230V line amperometers and voltmeters, generator control and power selector switch.



3 12V uses

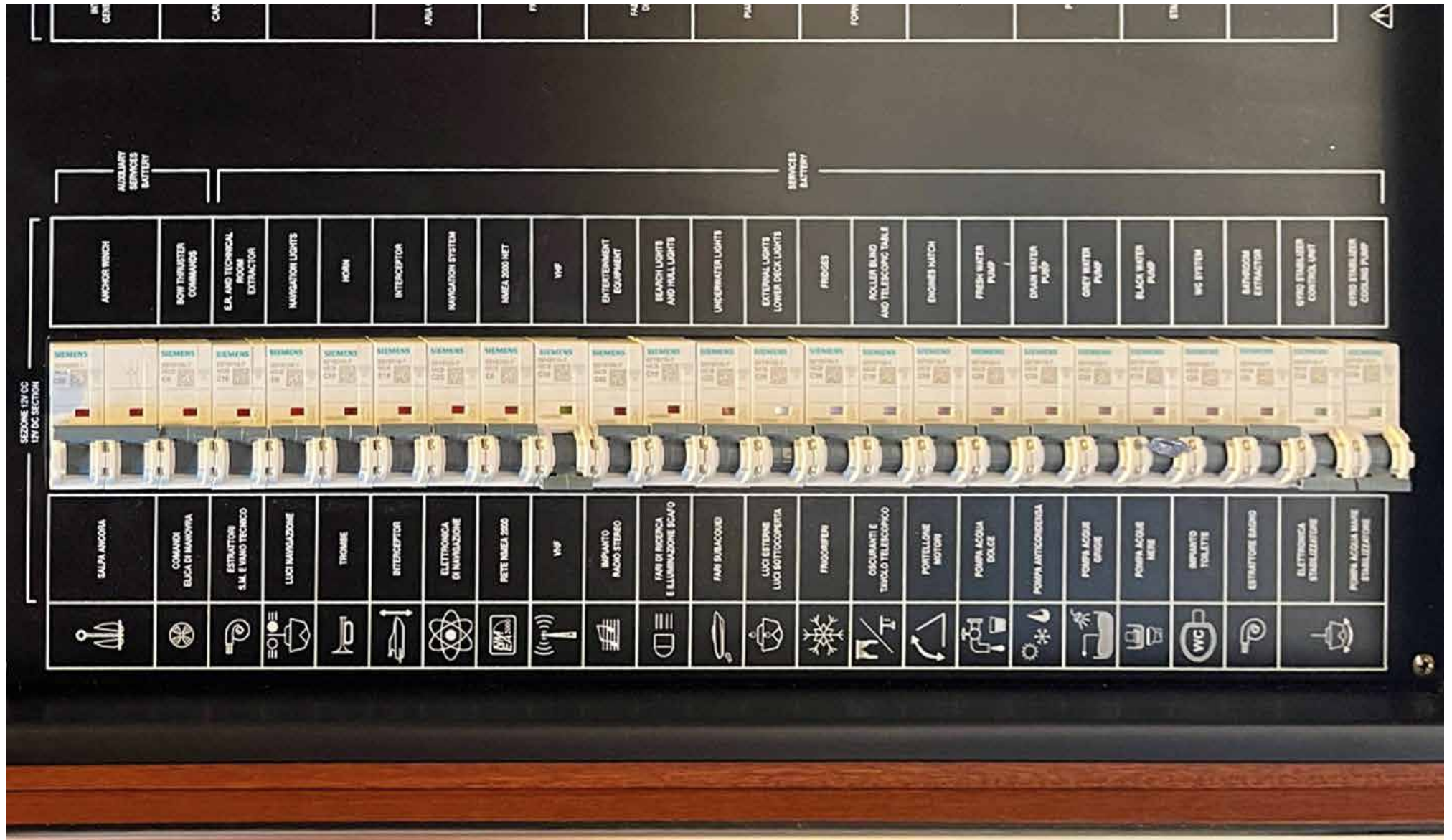

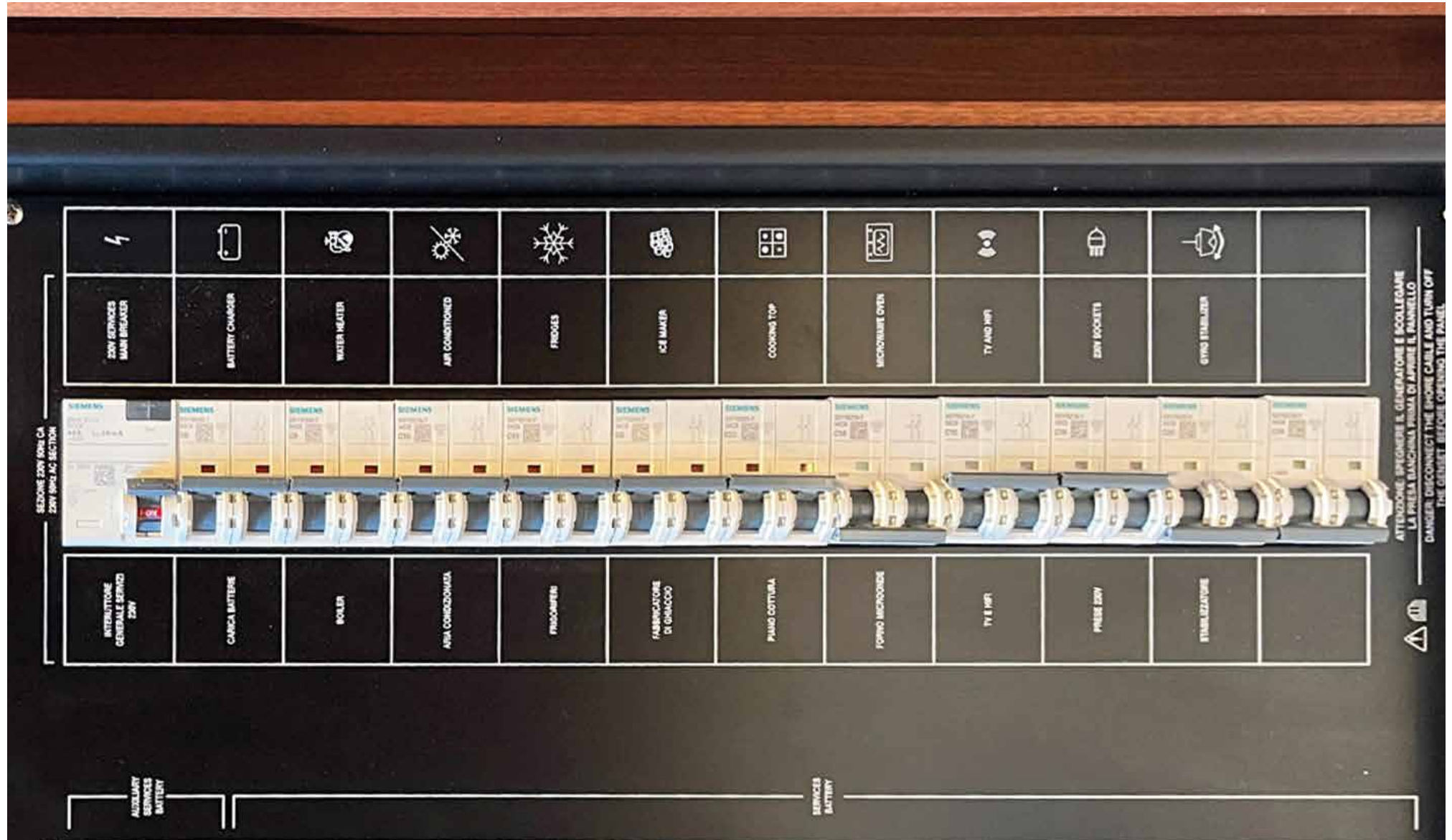

TECHNICAL ROOM ELECTRICAL PANEL

This is located at the bow end of the technical room and command:

- 12V safety system.



WARNING

Except in emergencies or extraordinary cases, always keep these switches on ON position.

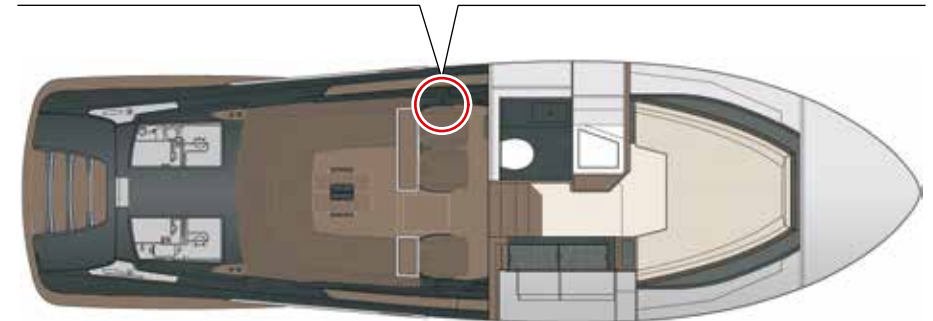

6.3 BATTERY SET

The propulsion engines' and the services' batteries of your yacht are located in the engine room, kept inside special protective boxes placed aft of the propulsion engines.

The batteries are normally recharged by the alternators driven by the main engines during their operation.

As an alternative, they can be recharged through a special battery charger supplied by the main electrical panel, from shore or by turning on the on-board generator.

The yacht is equipped with 5 batteries, divided as follows:

Description	Element number	Features element
Engine batteries	2	12V, 120Ah
Service battery	2	12V, 120Ah
Auxiliaries services battery	1	12V, 120Ah



DANGER

NEVER obstruct the air intakes of the battery boxes, as natural ventilation must always be allowed for the batteries so that they do not overheat.



WARNING

Do not lay objects on the cases containing the batteries.



WARNING

The batteries left unloaded over long periods of not operation, loose progressively their charge, until they become completely flat and get irreparably damaged.



CAUTION

A frozen battery may blow up if used or charged; do not start a Yacht with frozen battery. To prevent the battery from freezing keep it always completely charged.



DANGER

The battery releases explosive gas: do not approach sparkles or a flame nor smoke near it. If the battery is used or charged in a closed area, check for good ventilation. Do not check the battery charge by short-circuiting the terminals with metal tools: use a density gauge or a voltmeter.

**WARNING****EXPLOSION HAZARD**

Any lithium battery powered device on board must be recharged only in open air areas, connected to a suitable charging system. Also please refer to the device dedicated Use and Maintenance Manual.

NOTE

For further information on use and maintenance, please refer to the manufacturer's manual.

6.3.1 Checking and maintaining batteries

Component	Maintenance	Notes and precautions
Batteries	Battery check (accumulators)	The batteries installed are low maintenance batteries, with no special control needs: It is recommended, however, to check the status at least twice a year and whenever there is a difficulty or delaying of charging time.



CAUTION

In case of contact with battery acid, wash the contaminated part with fresh water for at least 15 minutes and consult a doctor.



CAUTION

Monitor the voltage of the engine and service batteries. During the charging phase 29.1V can be reached, this is a temporary value, well tolerated, both by the batteries and by the battery charger. This value must be monitored and, if this situation lasts for too long, the magneto-thermal breakers of the battery charger must be disconnected.



CAUTION

Remove bracelets, rings and every other piece of jewellery before working on the batteries.



CAUTION

Always keep the batteries charged and recharge them periodically even if the yacht is left unattended. If the charge level drops to the minimum, the batteries can get irreparably damaged. Check the charge status each week.



WARNING

All maintenance operations listed must be performed only by skilled personnel.



CAUTION

Stop the engine before inspecting or servicing the battery.
 Disconnect the battery cables before working on the electrical system to avoid arcing or damage to the alternator.
 Disconnect the negative (-) cable first, then the positive (+) cable.



WARNING

The battery replacement must always use the original model of battery originally furnished by the shipyard.

Carry out following checks:

- Check that the battery containers are clean and dry and that the terminals are coated with silicon grease and properly fastened. Clean and grease as required. Inspect at least every 6 months.
- Identify positive and negative cables, prior to connecting (connect the positive terminal first and then the negative, in order to avoid sparkles).

**DANGER**

Batteries may be subject to explosion hazard, with subsequent risks of serious personal injuries. Do not use open flames, smoke, cause sparks or use arc-welders in the area where batteries are located. Do not disconnect battery cables when the generator is running.

Battery acid may cause serious injuries. Wear safety goggles, gloves and protective clothing.

Do not wear any bracelet, ring or any other jewel when operating on batteries.

In case of contact with battery acid, wash the contaminated part with fresh water for at least 15 minutes and address to a doctor.

**DANGER**

Always remove the negative terminal (-) for earth connection first and connect it last.

**DANGER**

Operations on batteries must be performed by qualified personnel.

**CAUTION**

Check the condition of the batteries, making sure there are no traces of electrolytic corrosion on the poles and connection terminals; if corrosion is detected, contact servicing and replace the affected elements.

6.4 BATTERY BREAKER

Inside the crew cabin there is a panel which carries the lever switches of the batteries (battery breakers).

The battery breakers allow connecting, or cutting off, the batteries to/from their circuits.

- **Service battery breaker switch**
This switch allows cutting in or out the service battery set.
- **Auxiliaries service battery breakers**
This switch allows cutting in or out the auxiliaries service battery set.
- **Service/Auxiliaries service battery parallel connection**
If the service batteries are flat or not sufficiently charged for provide electricity to the on board uses, the battery breaker allows the parallel connection between service battery set and the auxiliaries service battery set, thus enabling the ordinary use of the uses.
- **Port and Starboard Engine battery breakers**
This switch allows cutting in or out the engines battery set.
- **Generator battery breaker switch**
This switch allows cutting in or out the generator battery and is located in the stern area of the engine room.
- **Direct devices breaker**
It allows you to insert or exclude the direct utilities such as bilge pumps and alarms.
- **Bow thruster battery breaker**
It enables or disables the power supply of the bow thruster.

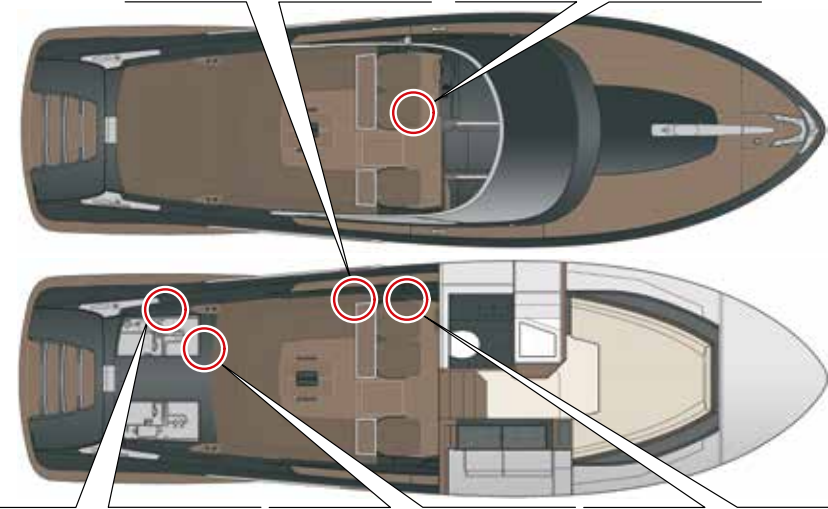

DANGER

Always keep the main breaker for safety systems and gangways in the ON position. Only disconnect in the event of maintenance or a fault.

**CAUTION**

This connection must be activated only if the engine batteries are not sufficiently charged. The battery parallel connection switch, must be activated only with buttons connecting the service battery banks and the engine banks set to ON.

**CAUTION**

Never disconnect the battery breakers with the engines running, because the engine alternators could get damaged.

Use the “Service/Auxiliaries service parallel connection” and “Engines parallel connection” battery breaker only if strictly necessary and disconnect it as soon as possible.

Leave the direct uses battery breaker always switched ON.

6.5 BATTERY CHARGER

On board your yacht there is a fully automatic and high-performing battery charger. The battery charger uses an optimized charging technique to rapidly and safely charge the batteries, while also supplying the connected uses. The charger is protected from short-circuits, overcharges and high temperatures (engine room).

On front of the battery charger, there's the monitoring panel which allows to control the operation of the battery charger and monitor the charging process.

The display in association with the charging bar shows the percentage of maximum current of the three battery systems together.

The symbol (V) in combination with charging bar shows the actual load voltage.

To switch to the "Output power" menu, press the ON/OFF button for 3 seconds.



OUTPUT POWER MENU		
LED	LED colour	Meaning
MODE	Solid orange	Output power menu
Battery 1	Solid orange	Current from 0 to 25%
Battery 2	Solid orange	Current from 25 to 50%
Battery 3	Solid orange	Current from 50 to 75%
Network communication	Solid orange	Current from 76 to 100%



CAUTION

The connection between the mains and the charger is not interrupted with the switch.



Efficiency

For correct operation, your batteries should not be discharged below 30-40% of their capacity, so, begin charging when you reach this level of charge. The battery charger is provided with a temperature sensor placed near the batteries. Depending on the temperature value detected, together with the remaining capacity value of the battery, the battery charger automatically adjusts the charging voltage according to the temperature greatly increasing the life of the batteries. Furthermore, in addition to the thermal compensation, the charger can compensate the voltage drop due to dispersion due to the connection cables. The battery charger is fitted with an integrated optical alarm function which is activated in case of special adjustment values are exceeded.

**CAUTION**

If the engines are ON, the alternators are charging the batteries; it is therefore advisable to keep the magneto-thermal of the battery charger to OFF, in order to avoid alternator damage.

**CAUTION**

Should the battery voltage drop under 9V, the battery charger will supply a current corresponding to the 25% of the maximum one and the recharge time will consequently increase.

NOTE

For further information on use and maintenance, please refer to the manufacturer's manual.

6.5.1 Battery charger maintenance

Component	Maintenance	Notes and precautions
Battery charger	Inspection charge output	<p>At least two or three times a year, have a specialist check the connection of each cable for looseness and oxidation.</p> <p>Keep the battery charger dry, clean and away from dust in order to ensure a good dissipation of heat.</p> <p>Periodically check the good condition of the cooling fan.</p>



DANGER

Do not work on the battery charger or on the electric system if they are still connected to a current supply. Disconnect the mains supply before connecting or disconnecting the battery. Modification to the electric system must be carried out exclusively by skilled personnel and only after the approval of RIVA.



CAUTION

Disconnect the shore power supply connections when the system is not in use.



CAUTION

The connection between the mains and the charger is not interrupted with the switch.



DANGER

Have the inner condition of the battery charger checked by skilled staff at least once a year. Faults like loose connections, burnt wires, etc., with following risk of fire spreading, must be repaired immediately.



CAUTION

If the engines are running, the alternators are obviously charging the batteries, so it is advisable to keep the battery charger magneto-thermal on OFF to avoid damaging the alternators.

**CAUTION**

Should the battery voltage drop under 9V, the battery charger will supply a current corresponding to the 25% of the maximum one and the recharge time will consequently increase.

NOTE

For further information on use and maintenance, please refer to the manufacturer's manual.

6.6 SHORE ELECTRIC SUPPLY

The yacht is equipped with a watertight plug with a plug-in connector, in accordance with regulations, for connection to the 230V 50Hz shore electric supply.

It is common to find sockets on the shore that are not of the same size as the one supplied or that have different amperages to those on the yacht; in this case, contact the harbourmaster's office for information on the type of amperage, the availability of a new plug or an adapter.

To supply 230V equipment with shore power supply it is sufficient to connect the electric cable to the power supply socket (1) on the shore and set the system through the switch on the electrical panel (2).

This procedure has to be carried out in the reverse order to disconnect shore power supply.

To use the electric shore power supply:

- Turn OFF the main AC shore power supply switch located on the main electrical panel.
- Turn OFF the switch on the shore column.
- Connect the shore socket cable; first connect the plug (female on the yacht) and then connect the plug (male) on the shore column.
- Turn ON the switch on the shore column.
- Turn ON the magneto-thermal on the shore.
- Check the voltage value with the voltmeter located on the main electrical panel in the salon.
- Turn (ON) the magneto-thermal on the main electrical panel.
- Before turning ON the magneto-thermals of all uses, check the correct voltages on the voltmeter.

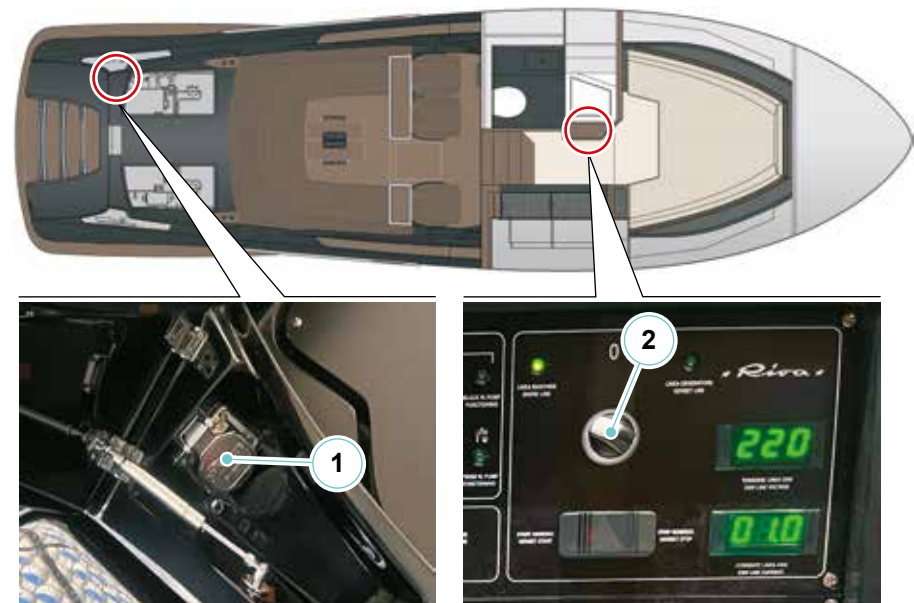

**DANGER**

Check that the shore power supply has a differential magneto-thermal protection before plugging it in.

**DANGER**

After connecting the plug to the shore, check on the voltmeter of the shore line panel that 230V 50Hz is present.

**DANGER**

Before connecting the shore socket, ensure the type of voltage and the sockets available, their integrity and the absolute absence of moisture on the wire, on the socket and on the plug.

With plug connected check that wire:

- Cannot get in traction as a result of tide variations, yacht movements, etc.;
- Cannot get crushed, etc.;
- Does not dive into water.

**CAUTION**

Do not modify connectors of shore power supply cable, use only plug compatible connectors. If the yacht power supply cable cannot be plugged into the shore socket, ask the Port Authority for an adapter. In any case, never use adapters cutting the mass conductor connection between the shore electrical system and the unit electric system.

The use of these adapters can irreparably damage the electric devices.

**DANGER**

Before carrying out any operation on the electrical system, detach all circuits and disconnect the shore power supply socket.

Before connecting to the shore power supply network, check that plug and socket are not spoiled and at any rate are perfectly dry.

NOTE

We recommend not leaving the shore cable connected when the yacht remains unattended.

**DANGER**

To reduce to the lowest the hazard of electrocution or fire:

- Open the switch for connecting the yacht to shore supply, before connecting or disconnecting the shore power supply cable;
- Connect the shore power supply cable to the intake socket of the yacht, before connecting the shore power supply source;
- Disconnect the shore power supply cable from shore power supply source first;
- Tightly fasten the lid of the shore power supply socket.

**DANGER**

Do not allow that the shore power supply cable floats in the water. It may cause an electric field that may cause injuries or death of the surrounding swimmers.

**CAUTION**

Disconnect the shore power supply connections when the system is not used.

**DANGER**

Before carrying out any intervention on the electric system, disconnect all circuits and the shore connection.

MAINTENANCE

At least once a month check the status of the outer sheath.
At least once a month check the status of the electric contacts and eventually protect them with proper products.
At least once a month check the status of the shore socket and eventually clean it.

**DANGER**

Risk of electric shock from leakage currents. Never swim in waters near harbours or marinas.

**DANGER**

Before carrying out any intervention on the electric system, disconnect all circuits (shore, generator, UPS/inverter):

- Disconnect the shore socket;
- Stopping the power generator and turn OFF the generator magneto-thermal;
- Disconnect the UPS and the possible inverter.

**WARNING**

If the indicator light on the main electrical panel is on, it means that the shore connection is inserted into the plug.

**CAUTION**

The connection must be performed under safety conditions with not powered connections and by paying attention to carry out a correct grounding.

**DANGER**

Do not leave shore power supply connected without people on board.

6.7 FUSE

On your yacht the fuses of the electrical system are located:

- **Electrical panel in the technical room:** fuses of utilities on-board.
- **Electrical panel of the engine room:** electronics protection fuses engine.

The fuses of your yacht has the following features:

- 1A
- 2A
- 3A
- 4A
- 5A
- 6A
- 6,3A
- 10A
- 12A
- 15A
- 50A
- 63A
- 125A
- 160A
- 250A
- 400A

NOTE

For their placement, refer to the wiring diagrams and Manufacturer's manual provided on board. In case of doubt, contact an expert technician.



WARNING

Where there is the necessity of having to replace a fuse, proceed to its replacement with a new one having the same characteristics in order to avoid damage to the load board.

6.8 GENERATOR

Your yacht is equipped with a generator set (1) (6kW 50Hz), operated by a diesel engine, dimensioned to satisfy the power supply requirements suitably planned in the electric balance for various navigation conditions.

The generator is fundamental when 230V equipment must be used while cruising, or when it is not possible to connect to the shore power supply mains.

The generator is located in the engine room, abaft the port propulsion engine, on a basement suitable to sustain its weight and induced vibrations.

The generator is contained in a sound-proof box, made of removable and insulating panels in painted marine aluminium. This solution allows easy access to the engine and to the alternator for maintenance and inspection, and at the same time a remarkable reduction of noise.

The generator is started using the 12V auxiliary service battery.

Aft of the generator is located the key battery switch that allows you to connect or exclude the generator starter battery.

The generator is equipped with an electronic device for automatically recharging the start up battery by means of its own alternator.

The engine is cooled down, through a cupronickel heat exchanger, by sea water sucked through an independent sea water intake, located in the technical room and equipped with a cut-OFF valve and an inspectable strainer (2).

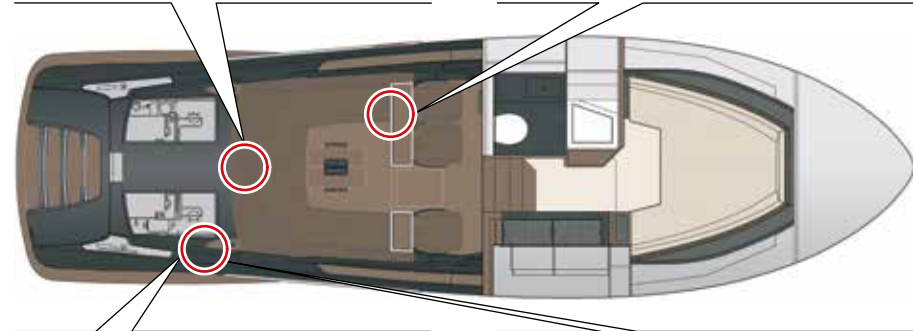
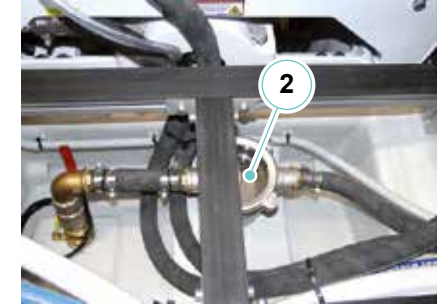

A second heat exchanger cools down the air inside a sound-proof case and the air necessary for the alternator ventilation.

The inspectable sea inlet strainer efficiently protects the cooling circuit from the harmful ingress of mud, sand and algae.

The generator draws the air necessary for combustion directly from the engine room through an opening in the stand; exhaust gases are collected and silenced, through a special muffler (4) and water/fume separator (3), inside the submersed exhaust of the port propulsion engine.

Besides exhaust gases, cooling water is discharged too. Immediately after the generator exhaust manifold there is the water injection point (raiser), where the mixture of cooling water and exhaust gas is formed.

The generator's exhaust, in addition to reducing the noise, collects the water in the exhaust pipes when the genset engine is switched OFF, preventing it from flowing into the engine through the exhaust manifold.

The water/fume separator divides the cooling water from the exhaust gas, discharging them overboards; it also further reduces the noise level, which is already reduced by the muffler.

The advantage of using this kind of exhaust is a considerable noise reduction, a lower grade of smoke of the exhaust and a reduction of the operating temperature.

The generator's start up battery can be recharged by the battery charger installed on the engine room.

The charger can only recharge the battery when the yacht's power supply is connected to the shore.

**DANGER**

Carbon monoxide poisoning. Start the generator only in a well ventilated area. The carbon monoxide, generated by the inner combustion of engines, is extremely toxic. Explosion/fire hazard. Check for the presence of fumes in the generator area.

Before beginning with any start-up procedure, it is extremely important to become "familiar" with the generator set and its controls.

You will also have to carry out an inspection, in order to remove any kind of danger, real or potential.

We therefore recommend you to carefully read the instruction manual supplied by the Manufacturer and, at any rate, to follow indications given.

- Identify the position of the emergency stop buttons, switches and other emergency systems installed on the generator.
- Knowing the specific emergency procedures relevant to the system concerned.
- Check for the correct oil level by means of the relevant dipstick.
- Check that all electric utilities are disconnected, to prevent starting the generator under load.
- Check that the water and fuel pipes are properly connected.
- Make sure that the sea water intake cut-off valve is completely open.

Start up the generator by pressing the START push-button located on the main electrical panel. Release the push-button when the generator is running. Be careful not to exceed 15 seconds continuously per attempt. Allow a break of at least 30 seconds between attempts.

Carry out a new engine running-in cycle as stated by the engine manufacturer. Heat the set engine by running it idle for about 5 minutes after start up, in order to allow the lubricating oil to reach all parts of the engine.

Otherwise, excessive wear of the moving parts may occur. Stop the generator set pressing the STOP push-button located on the main electrical panel.

**CAUTION**

Repeated start-up attempts with negative result may cause an excessive build-up of water in the draining system, with possible serious consequences for the engine.

**CAUTION**

Before stopping the generator, it is recommended to let it run for a few minutes with no load, in order to allow the engine and the alternator to gradually cool down.

Inactivity periods:

Start the power generator at least once a month.

If the power generator does not need to be used for a long time, it is necessary to proceed with the following operations:

- Change the engine oil.
- Replace the oil filter cartridge.
- Replace the fuel filter cartridge.
- Remove the injectors and insert 2 cc of engine oil into each cylinder, then let the engine run for several revolutions, manually operating on the pulley of the engine shaft. Then reinstall the injectors.
- Replace the sacrificial anodes.
- Disconnect the starting battery and place it in a dry location.
- Disconnect the sea exhaust pipe from the engine manifold.
- Clean the sea water strainer.
- Close the valve of the sea cock.
- Drain the cooling water from the muffler.

Generator sea water cooling system diagram

VISTA LATERALE
LONGITUDINAL VIEW

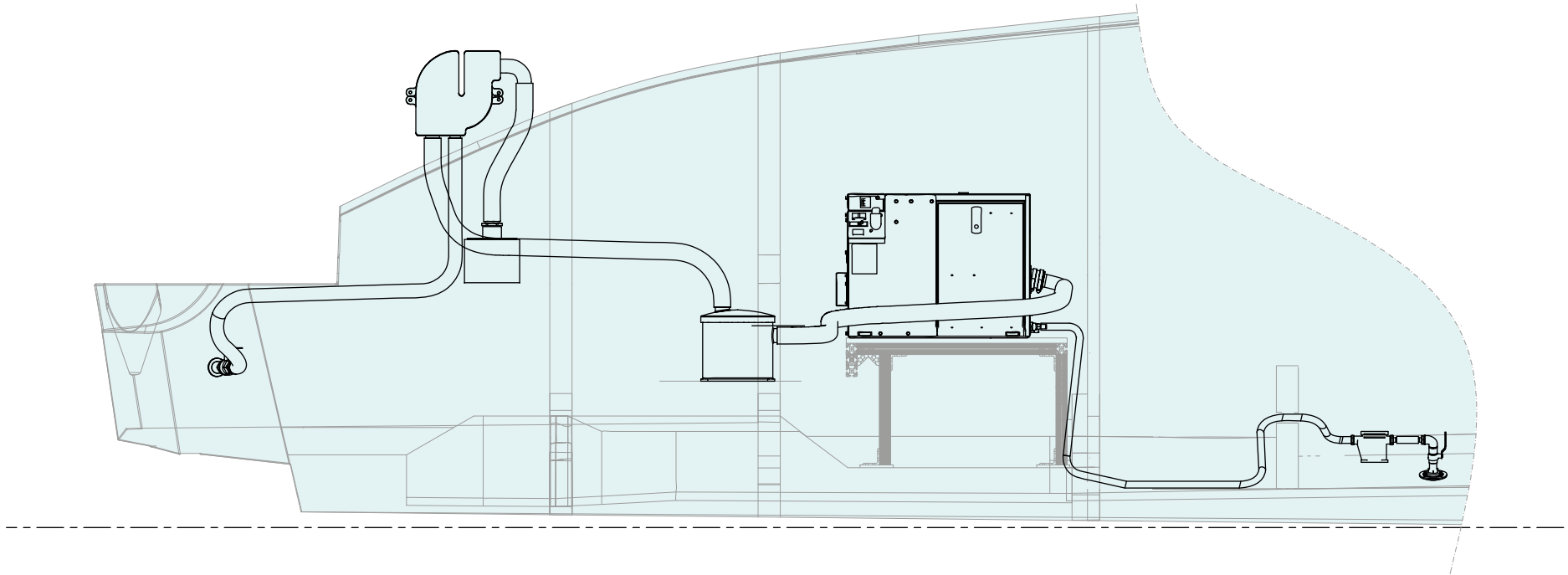

6.8.1 Generator control panel

On the power generator there is a control panel allowing to carry out the controls and the start/stop operations.
A display indicates, generator status and any detected anomalies, thus allowing the monitoring of the power generator set.



CAUTION

Before stopping the power generator, disconnect the various on-board uses supplied by it; stopping the power generator under load can irreparably damage the electronic control units of the various loads, beyond having a negative influence on the generator's operation.
However, please refer to the manual of the power generator to obtain more detailed information about the starting and stopping procedures.

NOTE

For further information on use and maintenance, please refer to the manufacturer's manual.



6.8.2 Generator maintenance

Component	Maintenance	Notes and precautions
Lubrication system	Oil specifications	Use specified oils according to Manufacturer's indication.
	Oil check	Check the oil level in the stand daily or before each start-up to ensure that the level is in the safe range. Remove the dipstick and wipe the end clean, reinsert as far as possible, and remove. Maintain the oil level between the marks (Min and Max).
	Oil change	For the oil change remove the draining hose from its holder. Position the hose in the oil collecting container. Remove the oil filling plug. Open the oil draining valve located on the engine and drain the oil completely in the container. Change oil according to intervals suggested by the Manufacturer.
	Oil filter change	Remove the oil filter by turning it counter clockwise by means of a suitable wrench. Apply a thin layer of oil to the rubber seal of the new filter. Replace the oil filter according at time intervals recommended by the Manufacturer.
Fuel system	Cleaning and replacement of fuel pre-filter	Replace fuel pre-filter at time intervals recommended by the Manufacturer.
	Cleaning and replacement of fuel filter	Close the fuel supply valve. Loosen the fuel filter by turning it counter clockwise. Remove the filter and clean the contact surface. Tighten the filter on the adapter until the seal comes in contact. Replace fuel filter within the intervals indicated by the Manufacturer.

Component	Maintenance	Notes and precautions
Cooling system	Cleaning / replacement of the air cleaner	Release the two spring clamps and remove the cover of the air intake. Clean the cover and the base with a clean cloth so as to remove the dirt. Refit the filter and the cover at the base of the filter air intake. Replace the filter at time intervals recommended by the Manufacturer.
	Cooling liquid top up	Before filling the cooling system stop the generator and let it cool down. Close the draining taps. In order to discharge the pressure turn slowly the plug clockwise up to the first stop. Remove the plug after the pressure has been completely released.
	Sea water strainer	At least once a week check for the correct water flow through the filters. At least once a month check the integrity of the filters. At least once a month clean the suction filter. At least once every six months check the condition of the cover seal.



ENVIRONMENT

Recover all waste materials (engine oil, fuel, filter, etc..) according to the rules in force concerning the special waste disposal.



CAUTION

If the oil level is not positioned between the two reference notches do not activate any device.



DANGER

Hot coolant and steams may cause heavy injuries or death.



CAUTION

Pay special attention to the coolant level. After the coolant drains, completely refill the engine coolant tank. Check the coolant level as prescribed in the Pre-start Checklist.



CAUTION

Failure to observe the oil specifications may cause inadequate lubrication/oil pressure and cold-starting difficulties.

**CAUTION**

Sea water damage. Sea water quickly deteriorates metals. Wipe up sea water on and around the generator set and remove salt deposits from metal surfaces.

**CAUTION**

Do not add coolant if the engine is still hot. Adding coolant to an hot engine can cause the cylinder block or cylinder head to crack. Wait until the engine has cooled down.

6.9 SACRIFICIAL ANODES

The submerged metallic parts of the yacht are protected against galvanic corrosions by means of anodes.

Check for their wear very frequently, as it depends also (and highly) on environmental factors like sea chains nearby, metal posts or docks, metal hulls moored nearby, electric devices, etc..

The replacement is necessary when the wear exceeds 50%.



CAUTION

Each time the yacht is lifted, check for the condition of the propeller, of the protection anodes and of the fastening system.
Replace the anode frequently.

6.9.1 Checking and maintenance of sacrificial anodes

Component	Maintenance	Notes and precautions
Sacrificial anodes	Periodical check (as necessary, according to the floating area) Assembly/disassembly	Metallic parts are protected against galvanic corrosion (caused by electrolytic currents due to the approach of different metallic bodies as steel or aluminium) by means of sacrificial anodes fitted on bottom hull, on stabilizer, on propeller shaft, etc.. The anodes' wear may depend on environmental factors as nearby chains, hulls or metallic docks, bad insulation of ground electric systems.

Periodical check

This operation must be carried out with yacht on dry dock or with the help of a diver.

Have the outer condition of the sacrificial anodes checked and have them replaced if they show evident signs of corrosion or if their volume is reduced to about 50%.

With the yacht out of the water, it is good practice to use a wire brush, to remove the surface layer of oxide and dirt on the external surface of the anodes.



CAUTION
Do not use pressurised water to clean the sacrificial anodes.



WARNING
For cleaning or inspection with the yacht in the water, disable engine start-up.



CAUTION
Failure to replace anodes will lead to corrosion on other metal parts.

Assembly/Disassembly

The sacrificial anodes are fastened to the yacht in several positions of the hull. We advise you to clean the seat of the sacrificial anode and cover with silicon the screws ends which fasten the anodes. This will ease the replacement of the anodes when worn out. We advise not to tighten the nuts fastening the anodes with glues or other materials which will hinder their removal.



CAUTION
Do not cover the contact surface between anode and hull with silicone.

Riva

RIVAMARE CENTO

PROPULSION SYSTEMS

CHAPTER 7

7.1 MAIN PROPULSION SYSTEM

The diesel engines are designed and produced with cutting-edge technology. The propulsion engines installed on board of your yacht, after accurate designing studies by RIVA, are perfectly suitable for this kind of yacht, also thanks to the high performances they are capable of providing. You will thus be able to enjoy high performance along with full reliability, to the advantage of your navigations and your and your guests' fun. The propulsion engines are provided with advanced electronics, in order to enhance the yacht's performance and reducing fuel consumption and exhaust emissions. Remember, however, that operation without problems and the expected high power may be attained only if the prescribed maintenance schedule is complied with and if recommended fuel and lubricants are used.

The electronic control system of the engines provides:

- Engine monitoring;
- Engine control;
- Automatic control of air/fuel rate;
- Acceleration torque modelling;
- Injection timing control;
- System diagnostics.

Each engine is directly flanged to its reversing gear with a joint or cardan shaft.

The engines have been installed on suitable elastic supports which absorb vibrations and enable minimum movement of the engine; in this way, the structures and the devices connected with them are not damaged.

In addition, the elastic supports allow easy adjustment of the position of the engines, either during new installation or after the expected settlement. The engines are equipped with diagnostic and monitoring electronic systems, whose aim is to check the important operating parameters of the engines and to alert the Captain in case they exceed the admitted tolerance.

ENGINE SPECIFICATIONS

Technical specifications	
Crankshaft power	294 kW (400 Hp)
Propeller shaft power	282 kW (384 Hp)
Engine speed, RPM	3500
Engine displacement	5.50 l
Engine configuration	In-line 6 cylinder
Compression ratio	1.59:1
Dry weight with DPI	780 kg (1.720 lb)

NOTE

For further information on use and maintenance, please refer to the manufacturer's manual.

7.1.1 Engine control panel

These panels are located in the cabin inside the port side cabinet. This station must be used only in case of emergency. The controls on the panel allow all procedures for yacht navigation to be executed in “Local” mode.

The engine can be started or stopped via the panel.

NOTE

For further information on use and maintenance, please refer to the manufacturer's manual.

7.1.2 Start of propulsion engines

Before starting the new or overhauled propulsion engines for the first time, carefully read the technical documentation supplied by the Manufacturers. During the first operating hours, we recommended that the engines not be run at more than 3/4 of their maximum load; initial run-in should be at variable speeds.

After this initial run-in, the engines can be gradually brought up to full output. Before starting the propulsion engines, always check that the sea water intake valves of the cooling system are completely open.

Also check that following levels are correct:

- Coolant level;
- Engine oil level;
- Fuel quantity necessary for navigation.

If necessary, fill with coolant mixture, oil and fuel.



CAUTION

Use only technical fluids approved by the Manufacturer, following the instructions provided by the Manufacturer. Engines must always be started with inverters in neutral position and throttle levers set to minimum speed.

Activate and check the correct functioning of the following utilities:

- Electronic engine starter key;
- Air extractors;
- Navigation lights;
- Horn;
- Electronic set;
- VHF.

**DANGER**

Before starting the engines, ensure that nobody is standing in the dangerous area.

NOTE

The electronic engine start system does not involve actually inserting the keys into the key slot, but simply swiping the key (E-key) on the engine ignition.



Carry out the following operations:

- Set the gearbox to neutral position by using the throttle installed in the helm position.
- Hold the E-Key in front of the panel, the system unlocks and IGNITION switches ON.
- Press and hold the “Start/Stop” button to operate the starter engine.
- Do not operate the starting engine for more than 10 consecutive seconds; if the engine has not started yet, release the push-button, wait for about 30 seconds and the operate the starting engine again.
- Once the first engine has been started, only after having verified its regular operation, start the second engine too, by following the same procedure described above.
- After engines start, verify that the oil pressure rises to normal values within 10 seconds. If low pressure condition persists, immediately stop the engines.

**CAUTION**

If you are forced to use battery parallel to start engines, it is advisable to disconnect all unnecessary equipment to avoid voltage drops.

Long idle operation may cause cooling of the engine and subsequent bluish or white smoke.

We therefore suggest avoiding long idle operation.

The slow run implies major wear of the engine mechanical parts and is the most harmful from the point of view of polluting exhaust.

7.1.3 Check after engine start up

After correctly starting the engines, it is necessary to carry out some operational checks.

- Check that, within 10 seconds from engine start, the oil pressure values stabilise.
- Check that there is no anomalous noise or excessive fume from the exhaust; otherwise, turn OFF the engines and contact RIVA After Sales & Service Department.
- Check that the alternators correctly recharge the batteries.
- Disconnect the 230V, shore cable, if still connected.
- Check for loose mooring ropes or floating objects hindering propeller movement.



DANGER

Make sure that no persons stand in front of gas exhausts and near the mooring ropes.

7.1.4 Stop of propulsion engines

Do not stop the engines immediately after a high-load operation, but let them run low (about 5 minutes) to balance the temperature differences.

The operations to be performed for engine stop are the following:

- Recall the throttle in central neutral position of the gear box;
- Press the STOP button;
- Disconnect magneto-thermal switches relevant to the engines start panel.



DANGER

Make sure that the engines cannot be restarted by unauthorized staff.

NOTE

With the engines stopped, carry out the following operations:

- Disconnect all unnecessary electric uses and check the electrical panel as well as the indications of the voltmeters and ammeters.
- Check the switches of the bilge pumps and their correct operation.
- Close the fuel supply line.
- Close the saltwater supply line.
- Do the hour meter reading and perform preventive maintenance according to the maintenance schedule.
- Check for possible leaks.
- Rinse the yacht with fresh water.
- Connect the electric supply socket from shore.
- Keep the air extractors running until they automatically stop.

7.1.5 Emergency stop of propulsion engines

Because of a mechanical or electric fault, the normal and useful procedures for stopping the engines could not be sufficient; it is therefore necessary to stop the engines with the EMERGENCY procedures.

- STOP buttons in the helm position (2):
On the main helm position there are the STOP buttons:
Press and hold them until the engines stop.
- STOP buttons in the engine room (1):
If it is not possible to stop the engines by using the stop pushbuttons located in the helm position, operate the selector control "STOP" located on the side of the engine.



CAUTION

The emergency stop causes heavy stress to the engines with consequent hazard of component damage. Use the emergency stop only in case of real emergency.



DANGER

Before restarting the engines after an emergency stop, make sure to find and to clear the reason of the fault.

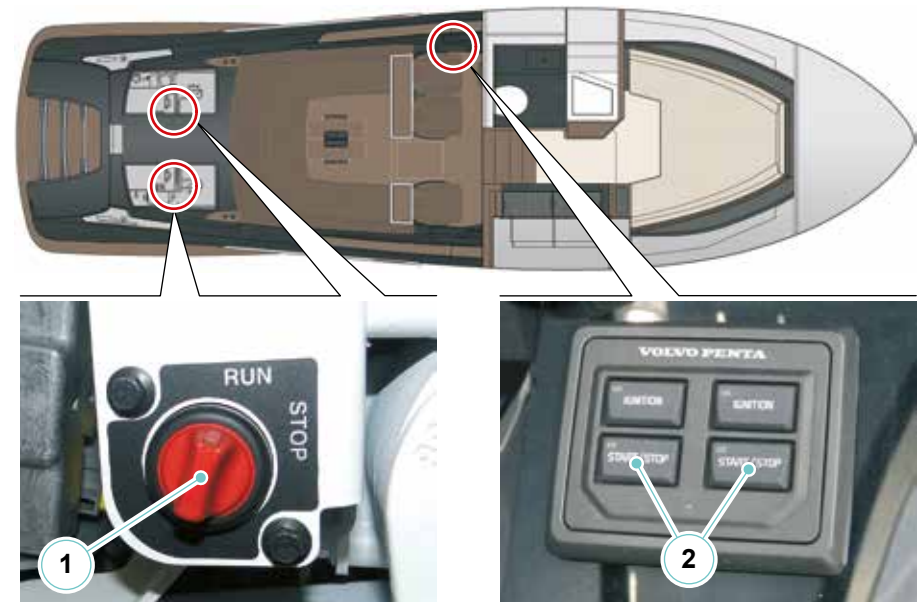



CAUTION

The engines emergency stop controls must be used only in case of real emergency.

Never use these controls during the normal engine stop procedure.

7.1.6 Propulsion engine maintenance

**DANGER**

Any maintenance intervention on the engines is to be carried out with the engines shut OFF, after they have sufficiently cooled down.

**DANGER**

Do not approach the V-belts or the engines pulleys with the hands, when the engine is running.

**DANGER**

Because of the high temperature in the engine room, oil or fuel leaks can evaporate and create a serious risk of fire. Regularly check the integrity of the system.

**CAUTION**

Only use the approved fluids indicated by Manufacturer, otherwise the warranty given by the Manufacturer is voided.

**DANGER**

A wrong use, a wrong maintenance, tampering and replacement of pieces, can cause serious damages or mortal events, beyond damaging the equipment.

The interventions on the electrical and mechanical equipment must be carried out by qualified staff after having examined the manual delivered by the Manufacturer.

**CAUTION**

It is absolutely necessary to view together with RIVA the documentation for the different components provided by the manufacturer; for any problem relevant to use or maintenance, please contact the Service Centres listed in the documents provided by the manufacturer.

Anyway, in case of need, some little interventions can be carried out by the staff on board, after consulting the operation manual.

**CAUTION**

During navigation, regularly check the cleanliness of the sea water strainer baskets.

If the yacht is navigating in a dirty sea area, check the condition of the strainers and clean them.

Caution is very important to prevent damaging mechanical parts (engines, generators, etc..), draining systems and to prevent jeopardizing the safety of the yacht.



CAUTION

Do not tamper or try to repair the injection pump or its power unit on a diesel engine. In case the lead seal is damaged, this will void the engine warranty.
Have the injection pumps or the injectors repaired only at an authorised Service Centre.



ENVIRONMENT

Dispose of waste materials (engine oil, fuel, filters, etc..) with respect for the environment and according to the rules in force.
Use only authorized disposal procedures and, in case of doubts, contact the Port Authority.

Component	Maintenance	Notes and precautions
Lubrication system	Oil level check	Check the oil level by means of the special dipstick; make sure the level is included in the allowable range (MIN - MAX). Do not start the engines if the oil level is not included between the two reference marks, as indicated in the Manufacturer's Manual.
	Oil and oil filter replacement	Replace engine oil according to time intervals and oil type suggested by the Manufacturer.
Fuel system	Cleaning of fuel pre-filter	Clean the fuel pre-filter with proper diesel oil and dry it with a compressed air jet.
	Drain of the fuel filter condensate	Each time the engine oil is changed, open the draining plugs and have the condensate flow out until only fuel comes out.
	Fuel filter replacement	Replace fuel filter within the intervals indicated by the Manufacturer.
Cooling system	Drain the cooling system	Drain the coolant only when the engine is stopped; follow the procedure indicated by the Manufacturer.
	Filling and draining	Refill with a mixture of drink water and antifreeze on ethylene glycol basis or anticorrosion agent.
V-belts	Check the belts condition	Make sure that there are no cracks, no traces of oil, no signs of overheating and no signs of wear; if so, replace them.
	Check the tension	Use the proper gauge supplied by the Manufacturer to measure the belt tension.
	Replacement of v-belts	Replace the v-belts at the intervals recommended by the Manufacturer.



Your yacht has a stern drive that transmits motion from the engine to the propellers.

Its twin propellers offer greater steering control in restricted waters and optimum performance in open waters, and also allow the yacht to glide at lower speeds to optimise its range.

The stern drive also has the task of directing the thrust of the propellers towards the desired direction.

NOTE

For further information on use and maintenance, please refer to the manufacturer's manual.

The propellers installed on your yacht are steel with a double counter-rotating propeller design.

The four blades at the front and three at the rear provide the best combination of speed, acceleration and grip.

In the event of impact with the seabed or submerged/semi-submerged objects, check the condition of the propellers immediately.

In the event of noticeable vibrations, reduce engine revolutions to a minimum and head to port for repair, as increased vibrations could cause damage to the yacht's propulsion parts and structures.

7.3.1 Propellers check and maintenance

Check the edge of the propeller frequently for dents or damage.

If deep dents, cracks or tears are noticed, they must be replaced or repaired. Mineral deposits on the propellers can be caused by a malfunctioning or missing cathodic protection system.

Remove mineral deposits on the propellers with household cleaners suitable for dissolving limescale and deposits.



DANGER

Checking, cleaning and maintenance of the propellers must only be carried out with the engine stopped and prevented from being started.

Component	Maintenance	Notes and precautions
Propellers	Periodical checks	<p>The propeller check should be performed according to the floating waters. Inspection and possible cleaning may be carried out with the yacht in a dry dock or with the help of a diver.</p> <p>Check if the propeller blades have notches, fractures, fouling or barnacles which may have a negative influence on the yacht's performance during navigation. If you notice corrosion, check the anodes conditions and replace the propellers for major failures.</p>
	Assembly/disassembly	Replace only with genuine spare parts supplied by the RIVA After Sales & Service Department.



DANGER

Make it impossible to start the engine when working on the propellers.



CAUTION

Do not replace the propellers of your yacht with other of doubtful origin.
Contact the RIVA After Sales & Service Department.
Each yacht model has its own propeller.



WARNING

Damaged propellers should be replaced immediately.
Operating the yacht with a damaged propeller should be undertaken with extreme care and only at reduced engine speeds.

7.3.2 Disassembly and reassembly of propellers

A tool for removing and fitting the propellers is supplied together with the Transom shield kit (see figure).

Dismantling

- Start the engine and set the engine throttle on reverse.
- Disable the engine and prevent its activation.
- Undo the lock nut (1) and remove the rear propeller.
- Start the engine and set the engine throttle in forward gear.
- Disable the engine and prevent its activation.
- Undo the large lock nut (2) using the special tool supplied.
- Remove the front propeller.
- Wipe the propeller shafts clean.

Assembly

- Lubricate both propeller hubs.
- Start the engine and set the engine throttle in forward gear.
- Disable the engine and prevent its activation.
- Push the front propeller onto the shaft.
- Screw on the large lock nut (2) and torque tighten to 50-70 Nm (37-52 ft·lb).
- Start the engine and set the engine throttle on reverse.
- Disable the engine and prevent its activation.
- Push the rear propeller onto the shaft and secure it with the lock nut (1). Torque tighten to 70-80 Nm (52-59 ft·lb).

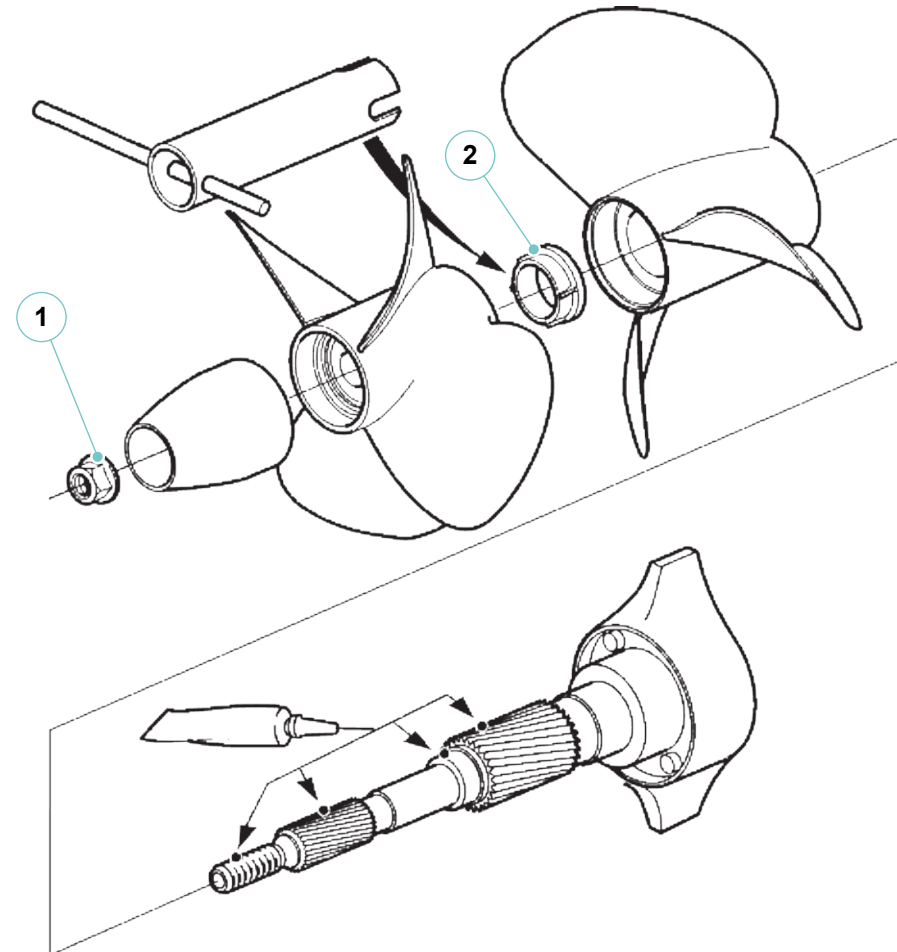

7.4 ENGINE GAS EXHAUST DUCTS

The engine fuel exhaust is integrated into the stern drive.



CAUTION

The exhaust system must be perfectly gas tight to prevent any possibility of poisoning.

Anyhow, with time, vibrations and the parts elongation caused by the heat can impair the correct tightness of the system. Therefore, frequently check the condition and tightness of the ducts.



DANGER

During engine operation, or immediately afterwards, the exhaust ducts of the engine reach very high temperatures, thus creating the risk of burning or scalding.

7.5 FUEL SYSTEM

The fuel deposit of your yacht consists of two tanks (1) installed in the engine room, close to the fore bulkhead, reinforced internally and certified and tested by RINA.

The tank's total capacity is 1000 litres (264 gals).

Inside the tank there are some antilapping bulkheads (diaphragms) in order to avoid an excessive swashing of fuel due to the wave motion of the sea.

Hermetically sealed inspection flanges are bolted on the tank, through which all fuel delivery and return passages occur.

The refuel plug (2), through which the tank is filled by gravity, and closed by a screw plug, is located on the starboard side.

The fuel intake of the yacht is equipped with a flow switch having the function to prevent undesired leaks of fuel from the plug and from the vent which may stain the bridge and pollute the surrounding waters.

The fuel bleeding from the intake ducts is collected by a tank with suitable capacity which, on its turn, will be drained automatically into the fuel tank through the relevant return duct.

While boarding, the fuel flow produces a lot of foam; if it comes out, you might think the tank is full.

Therefore, it is good to wait for a few minutes and then top up, in order to be sure that the tank has been completely filled.

The vent piping, with flame-breaking net, connects the upper part of the tank to the wind-proof discharge located on the yacht's starboard side.

NOTE

We recommend filling the tank some hours before departure; in this way, the impurities and water in the fuel will decant on the tank bottom as they are both heavier than fuel.

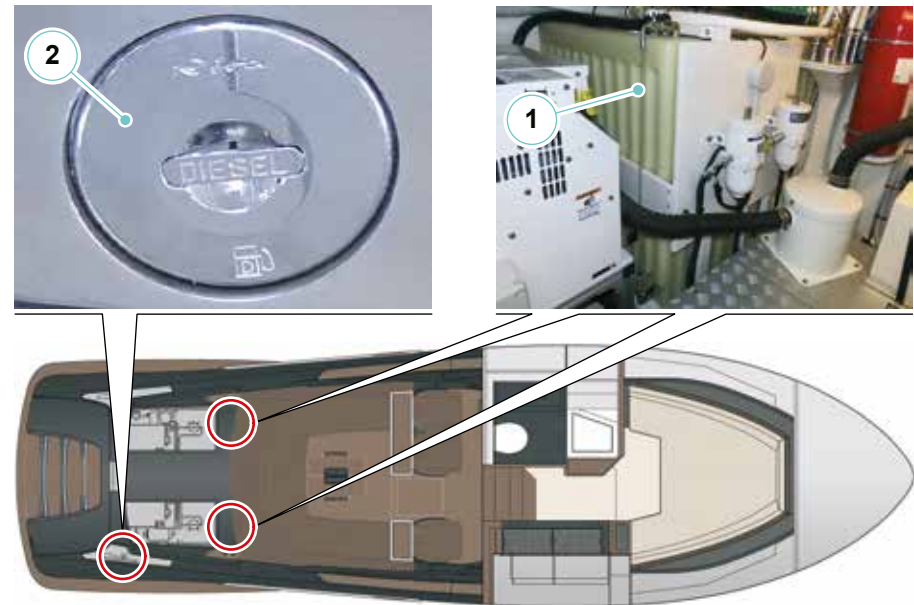

It is necessary to regularly drain the condensate water from the tank and the separator filters.

The particular shape and arrangement of the tank eases settlement of possible impurities or water which may be present in the fuel; it is advisable to carry out tank drain, by means of the special air valve, a few hours after refuel, and possibly while the yacht is stopped.

It is also advisable to connect the bleeding valves delivery to a hose, conveying the liquid into a bucket in order to avoid collecting flammable fuel in the bilge, thus preventing the formation of noxious exhalations.

The fuel level, shown on the helm position digital display, is detected by the electronic level switch installed near the tank itself.

In addition, there is a visual fuel level in the engine room on both tanks.



DANGER

Because of the high temperature in the engine room, oil or fuel leaks can evaporate and create a serious risk of fire.

Fuel leaks can cause fire. Regularly check the integrity of the system.



ENVIRONMENT

Handle water mixed with fuel and dispose of it according to the rules in force. Use only authorized disposal procedures and, in case of doubts, contact the Port Authority.



CAUTION

The inlet plug carries the indication "DIESEL" to avoid accidental input of different fuels.

To avoid damage to the system and tanks, we recommend refuel by gravity and not by pressure.

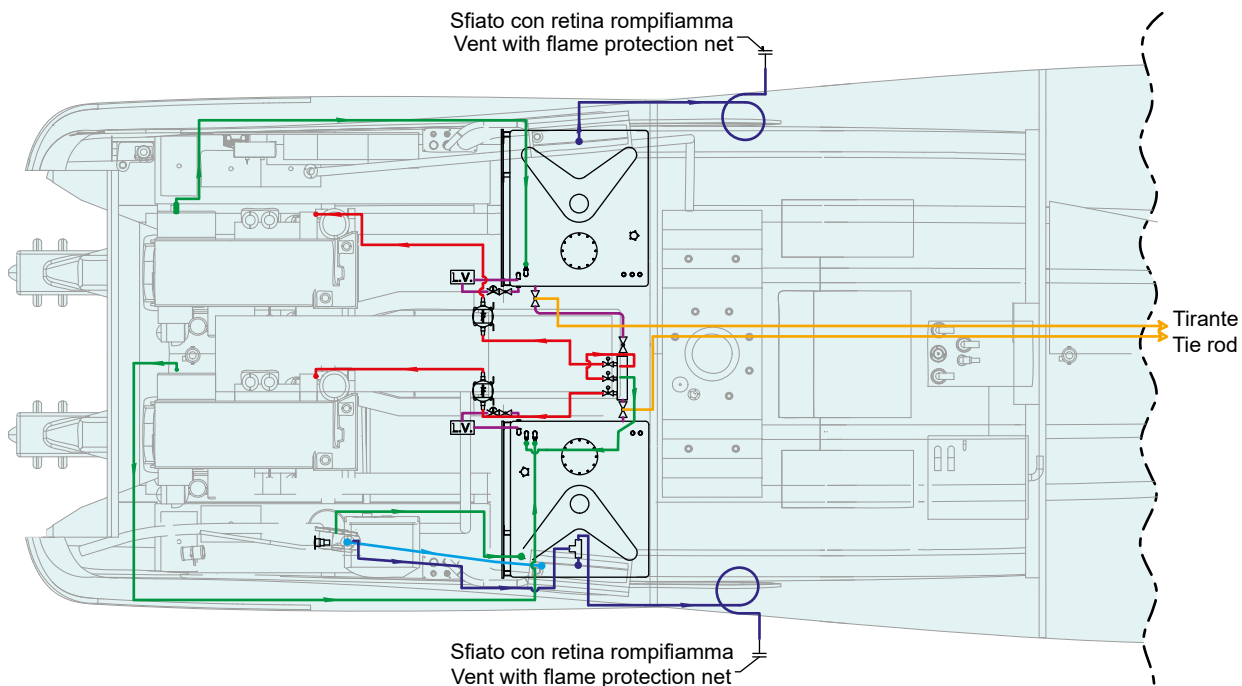

ICONA ICON	DESCRIZIONE DESCRIPTION
	Prefiltro singolo Single prefilter
	Valvola a sfera intercettazione Shut-OFF valve interception
	Interruttore di flusso Flow switch
	Rubinetto a pulsante Pushbutton valve
	Collettore mandata gasolio 3 vie 3-way manifold Diesel supply
	Valvola a sfera Ball valve
	Sfiato con retina parafiamma Vent with flame protection net
	Tappo imbarco carburante Filling cap
	Elettrovalvola mandata gasolio Diesel supply solenoid valve
	Linea di mandata Suction line
	Linea di ritorno Return line
	Linea di sfiato Venting line
	Linea di riempimento Filling line

7.5.1 Fuel quality

For the good performance of the engine installed on your yacht, fuel quality is of primary importance.

Fuel should be purchased from reliable high-sale filling stations, for both the quality and a probable short stay of fuel inside the shore tank.

The fuels:

- European Standard EN590
- DIN EN 590 (Germany)
- ÖNORM EN 590
- ASTM D975 No. 1D (USA)
- BS 2869 Part 1 Class A 1 (United Kingdom)
- BS MA 100 DMX (Marine Diesel Fuel)

are suitable to supply the engine.

If the above type of fuel is not available in some countries, follow the rules indicated in the manual relevant to the engine.

**CAUTION**

Stop the engine when refuelling.

**WARNING**

For the type of fuel to be used, follow the manufacturer's recommendations. Diesel engine require very clean fuel. Keep filters clean.

**WARNING**

If fuel containing water reaches the engine it can seriously damage the injection system. To avoid this, drain water from the fuel tank and service regularly the fuel/water separator filter.
During winter service do not use fluidity correctors.

**CAUTION**

It is recommended to empty and clean the tank periodically and at least once a year.
Remember that reused fuel must be filtered.

7.5.2 Water/fuel separator filter for engine

Maintenance and water drain from collection tank

Bleed frequency or the replacement of the filter element (1) are determined by the contamination level of the fuel.

Check or drain the water collection tank (2) daily.

The collecting cup must be drained before polluting agents reach the turbine end, i.e. when the water detector (3) sends the alarm signal indicating the need to drain water.

- After having placed a capacious collection container underneath it, open the drain to discharge containments.
- Remove the cover (4) and fill with clean fuel.
- Close the cover and tighten the T-handle (5) firmly by hand.

Replacement of filter element

Replace the element according to the schedule recommended by the manufacturer or if a lack of power is noticed. Power loss indicates that the element is indeed clogged. Other factors such as overfilled tanks or excessively contaminated fuel can also clog the filter.

- Close the seacock.
- Remove the cover.
- Remove the element by holding the handle and by pulling lightly forward with a twisting movement.
- Insert a new filter having the same filtering features of the one replaced.
- Check and, if necessary, replace the filter cover gasket. Apply a layer of clean fuel or engine oil on the seal before reinstalling it, insert the new element with a slow twisting movement downwards.
- Fill with clean fuel, then replace the cover. Tighten the T-handle manually and reopen the valve.
- Start the engine and ensure there are no leaks. Repair any leaks with engine shut OFF.

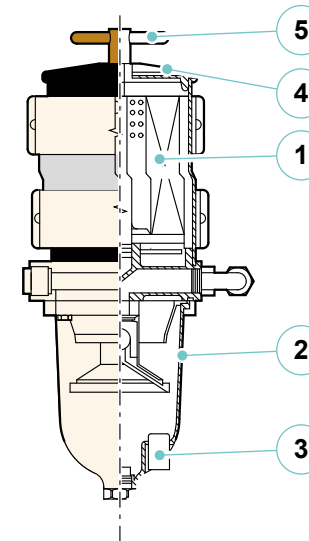

Troubleshooting procedure

The main reason for a poor start-up or lack of power is the result of a clogged filter or of an air leak in the fuel system. If the device does not prime or does not hold the idle run, or air bubbles are visible through the check glass, first of all check the cover by means of the T-handle and vent it, if it had not been closed properly. Then check all connections and lines and make sure that no fuel line is clogged with contaminants.

If the problem persists and the filter element is new, contact technical support.

**CAUTION**

The separator filter must be checked periodically as indicated by the Manufacturer in order to avoid impairing the engine's functionality.

MAINTENANCE

At least once a month check the operation. At least once a week, and anyway before each refuelling, check for the presence of water in the fuel. If necessary drain the water present. When necessary, but at least once a year, replace the cartridge of the filters.

NOTE

For further information on use and maintenance, please refer to the manufacturer's manual.

7.5.3 Fuel system maintenance

Component	Maintenance	Notes and precautions
Fuel tank	Bleeding	<p>Bleed the tank every 2 refuels and at least once a month, in order to prevent condensate water and various impurities from entering the fuel circuit. Wait some hours from refuel to allow impurities and water to deposit.</p> <p>Do not discharge bilge water containing bleed fuel into the sea, but collect it and discharge it to the appropriate areas on land for hydrocarbon disposal.</p>
Separator filters	Cleaning and purging	Bleed the separator filters at least once a month in order to drain condensate water and various impurities collected in the special lower cup. Periodically replace the filtering element, increasing frequency if necessary.

7.6 BOW THRUSTER

The bow thruster (1) is a very simple and strong device, but it requires some special care:

- The thruster must be used at a very low speed, or without fresh way;
- The Manufacturer, considering the excessive overheating, has foreseen a continuous run of max. 3 minutes. The electric engine (2) is equipped with a built-in protection magneto-thermal, which stops the electric engine, in case it overheats and starts it again once it has cooled down. You should consider this when planning the manoeuvres to carry out;
- Each time the yacht is lifted, check the condition of the thruster, of the protection anode and of the fastening system.

On the battery breaker (3), located in the technical room is a manual button with two positions:

- ON: in this position, the battery breaker may be automatically closed/opened by respectively turning ON/OFF the thruster's control panel;
- OFF: in this position, the battery breaker is always OPEN, regardless of the turning ON/OFF of the thruster's control panel.

To close the battery breaker and have the thruster powered and ready for the manoeuvre, in general, it is necessary to:

- Position the automatic battery breaker to the ON position (button "extracted");
- Close the engine battery breaker;
- Turn ON the thruster control selector by simultaneously pressing the "ON" keys.

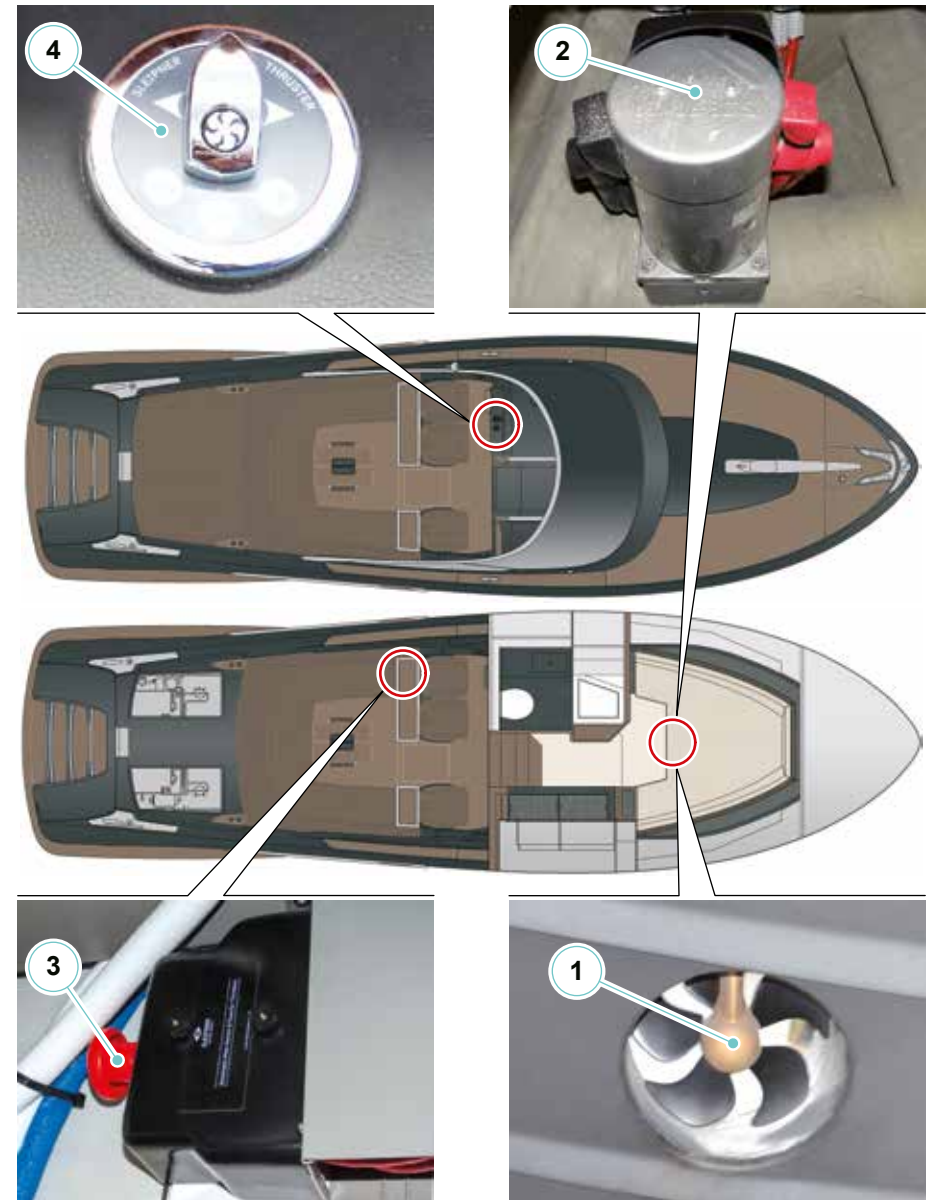

Use of the bow thrusters:

Before using the thruster, activate the battery switch. After activating the power supply, press the "ON" button on the helm position control panel (4). The warning light indicates that the device is ready for use.

The thruster motor is controlled by the control selector.

When the thruster is no longer in use, press button OFF.

Before getting on land, disconnect the switch and the battery switch.

**DANGER**

When using the thruster, be careful of any swimmers that may be in the immediate vicinity of the propeller openings.

Do not test the thruster when the yacht is outside water, unless you are sure the workers are at safety distance from the thruster tunnel.

**CAUTION**

Always disconnect the related magneto-thermal when the thruster is not in use.

**DANGER**

Always stop the thruster before carrying out checks or maintenance by disconnecting the magneto-thermal.

**CAUTION**

When the bow thruster stops supplying the thrust while the electric motor turns, there might probably be a fault in the transmission system. In this case, immediately disconnect the bow thruster.

**CAUTION**

Never activate the bow thruster longer than one second when the yacht is at dry shore, because this can damage the electric motor seriously.

**CAUTION**

When you leave the yacht, or during maintenance work on the thruster, you must turn all the battery switches on board to the manual OFF position.

**CAUTION**

In case it is necessary to replace a fuse on the system thruster, to involve a technical competent naval electrician.

Be sure to view the preliminary technical and operational documentation relative or contact RIVA After Sales & Service Department.

NOTE

For further information on use and maintenance, please refer to the manufacturer's manual.

Riva

RIVAMARE CENTO

STEERING SYSTEMS

CHAPTER 8

8.1 STEERING SYSTEM

The steering system is placed directly on the sterndrive engines. Slack pistons (1) are controlled by a joystick (low speed manoeuvres) and rudder on the dashboard and are moved thanks to the electronics of any single engine.



CAUTION

Each sterndrive has an electronic management used. In case of failure or malfunction of a sterndrive, you can keep control of the yacht using the other operational.

NOTE

For further information on use and maintenance, please refer to the manufacturer's manual.



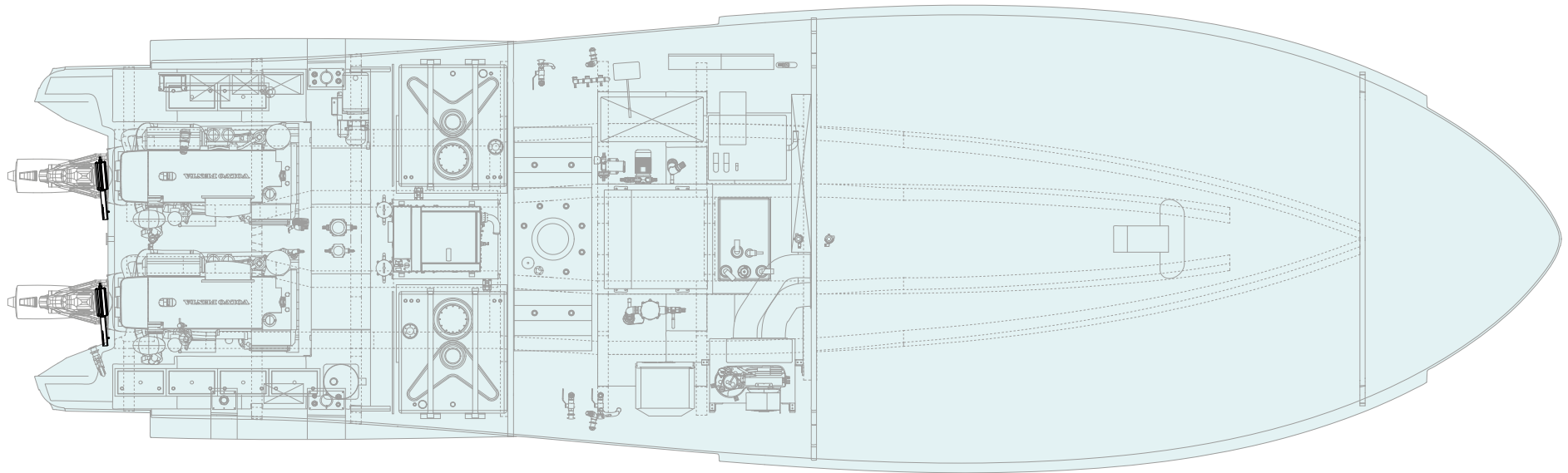

8.1.1 Trim range

Trim range is any angle between -5° and 8° . This range is used to obtain the best comfort and economy at all running speeds (from start to maximum speed).

The trim number corresponds to the drive angle in relation to the horizontal (stationary yacht).

NOTE

The lowest value can vary from yacht to yacht depending on the angle of the transom.

Beach range

Beach range is any angle between 8° and 30° .

This range is used for running at reduced speed in shallow water or where water depth is uncertain.

Tilt range

Tilt range is any angle over 30° .

It is used to lift the drive to maximum height, but not when the engine is running.

This range is used for trailering or putting the yacht on the trailer.

Power trim has an automatic stop that cuts the power when its end limit has been reached.

The stop is reset automatically when activating down trimming.



CAUTION

Operating in beach range or tilt range will cause significant loss of manoeuvrability.

Operating in Bow-up Position

The bow-up position is normally used for cruising, running in a rough sea, or running at full speed.



WARNING

Avoid excessive trim (bow-up) when crossing wakes or rough seas, the yacht's bow may rise or fall sharply, possibly injuring the yacht's passengers.

Be aware of these undesirable conditions that can occur when running in a full bow-up position:

- The yacht may tend to self-steer. You may have to compensate with the steering wheel to keep the yacht on a straight path.
- The yacht's bow will tend to raise clear of the water. This reduces forward visibility from the helm.
- Excessive bow-up trim will cause propeller ventilation resulting in propeller slippage.
- Engine RPM will also increase, but yacht speed will not increase and may even drop.

Operating in bow-down position

The bow-down position is normally used for acceleration onto plane, operating at slow planing speeds, and running against a rough sea.

**WARNING**

Avoid excessive trim-in (bow-down) when operating at speed and/or in rough seas.

The yacht's bow may dive in to oncoming waves, causing the yacht to bow steer or spin rapidly, possibly injuring the yacht's passengers.

Be aware of these undesirable conditions that can occur when running in a full bow-down position:

- The yacht may tend to self-steer. You may have to compensate with the steering wheel to keep the yacht on a straight path.
- The yacht's bow will tend to go deeper into the water, reducing ride quality.

Trim/tilt engine protection

The trim/tilt engine is protected from overheating by an internal thermal overload switch.

If the trim switch is held too long at either full up or full down, the electric motor may stop.

If the engine stops, release the trim switch and wait for 20 seconds. Then try the switch again.

8.2 INTERCEPTORS SYSTEM

To improve the yacht's performance during navigation, they have been installed on the transom two hydraulic interceptor, one on the starboard and one on the port side for variation both longitudinal and transverse alignment.

The controls are integrated into the main engines throttle with ATCS (automatic trim control system).

In the engine room, they are located on the control units with built-in oil tank. In principle, lowering and raising the interceptors is obtained, respectively a lowering and a raising of the yacht's bow.

Correct positioning of the interceptors results in a stable and ideal set-up that can increase speed while reducing fuel consumption.

In particular navigation conditions, when the effect of lateral forces of the sea, sea currents and wind, the yacht assumes a tilted position, to restore the normal conditions keeping the route, it is necessary to act on the steering wheel or with the use staggered the interceptors.



CAUTION

Interceptors are normally used during cruising, both to make it more comfortable and to achieve better performance of the yacht, according to the sea and navigation condition, and the yacht loading.



CAUTION

When using reverse gear, set the interceptors fully up, otherwise they may be damaged.

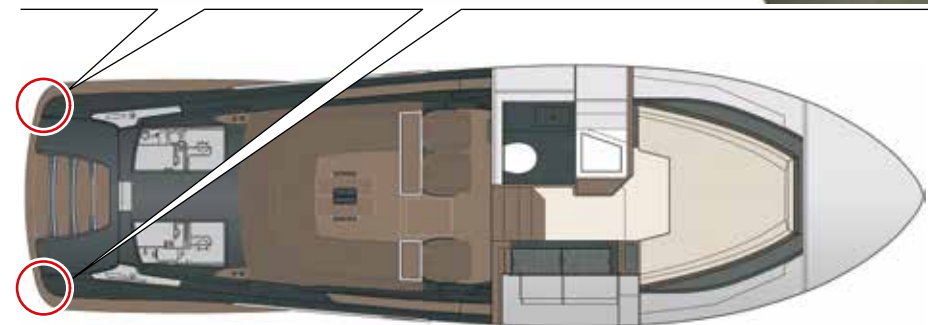

**CAUTION**

The interceptors, as well as transmission systems, can suddenly change the yacht direction if operated too rapidly or with high angles of incidence, especially with increasing yacht speed and during manoeuvres (as they are usually sized and optimized for intermediate speed). It is therefore necessary to get well familiar with their use and related devices reactions in any condition and especially at high speeds.

**CAUTION**

Interceptors can give sudden changes of direction to the yacht if they are operated too quickly. It is therefore necessary to test the response of these elements in the open sea and very carefully.

**CAUTION**

The manual use of Interceptor ("trim assist" function disabled or override), running at high speed, requires special attention and it is normally not recommended.

**DANGER**

As is good practice on a yacht, always make sure that passengers are seated before performing large adjustment manoeuvres on the interceptors, especially if you are navigating at high speed.

NOTE

For further information on use and maintenance, please refer to the manufacturer's manual.

8.3 GYROSCOPIC STABILIZER

To reduce the annoying effect of the wave-induced rolling motion, a system has been installed comprising a gyroscopic stabilizer capable of generating a rotation equal and opposite to that of the waves. The system provides a remarkable reduction of the pitch both with the yacht stationary or during navigation with low energy consumption that does not impair the quality of life on board and does not affect performance. Thanks to these important features, the device can also be kept on at night to allow a greater comfort by damping almost completely the annoying rolling motion.

The system consists of a gyroscopic stabilizer positioned in the technical room.

The gyroscopic stabilizer is controlled by means of the digital display on the helm position.



CAUTION

Have the scheduled PERIODIC INSPECTION performed by skilled personnel every two years.

NOTE

For further information on use and maintenance, please refer to the manufacturer's manual.

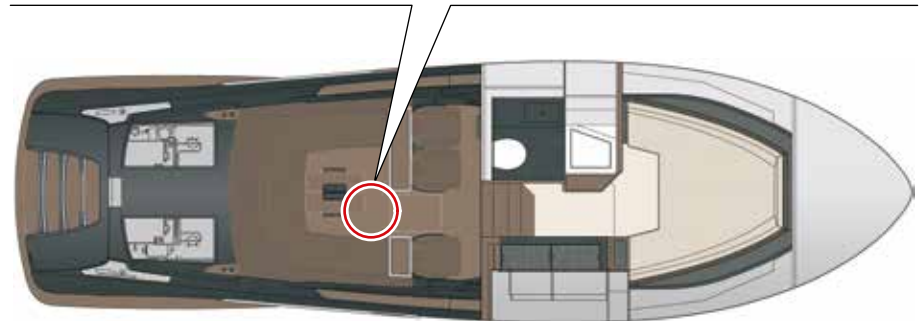

Riva

RIVAMARE CENTO

AIR CONDITIONING AND VENTILATION

CHAPTER 9

9.1 AIR CONDITIONING SYSTEM

The air conditioning system (1) installed on your engine yacht has a very high efficiency and comfort standard.

Air conditioning includes cooling and dehumidification in summer (summer cycle), heating in winter (winter cycle) and air purification, circulation and ventilation in every season. The yacht is provided with a fresh water circulation system (treated water), using a refrigerator (Frosty) with heat pump (with sea water condensation), which allows adequate air conditioning of the lower deck.



CAUTION

Clarity of the operating principle is extremely important for correct management and maintenance of the system, for locating faults and keeping the system fully efficient.



CAUTION

Before each starting of the system, make sure that the sea water intake valve (2) is open and check the cleanliness of the filter.

NOTE

For further information on use and maintenance, please refer to the manufacturer's manual.

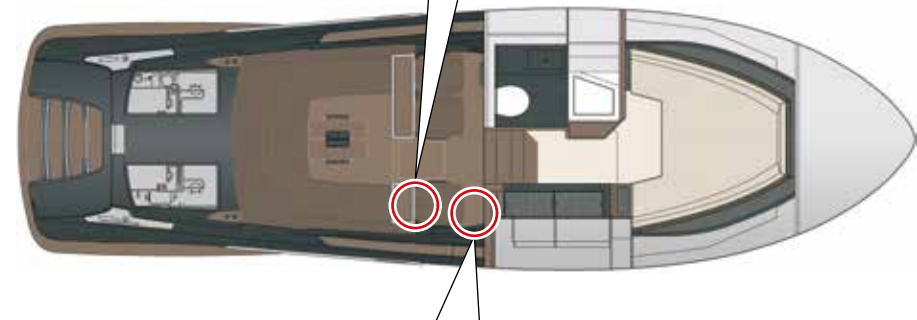
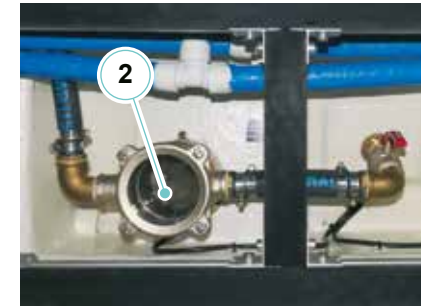

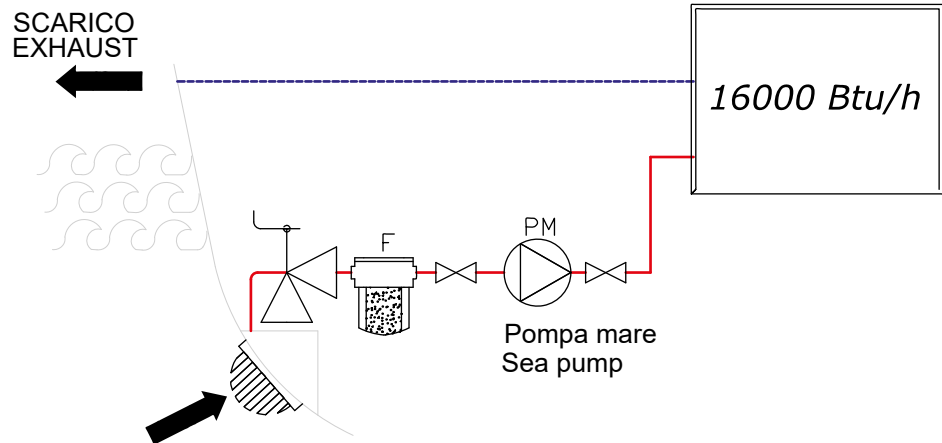
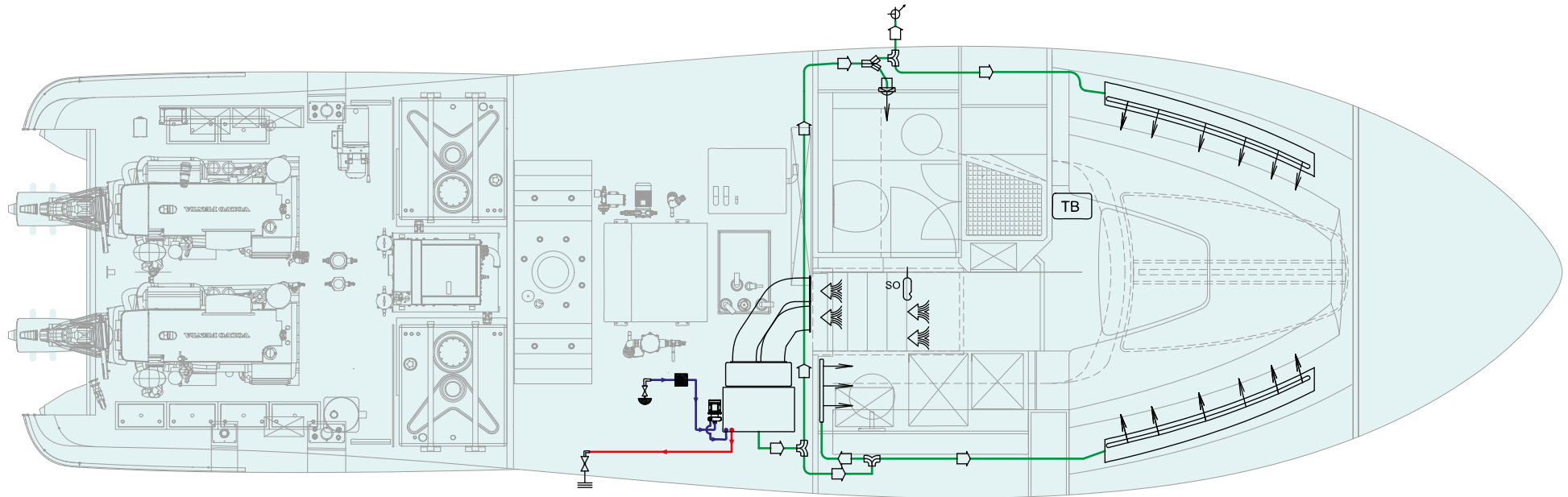

ICONA ICON	DESCRIZIONE DESCRIPTION
	Dal ponte inferiore From the lower deck
	Al ponte superiore To the upper deck
	Sonda temperatura Temperature probe
	Pannello regolazione ambiente Room control panel
	Ripresa aria Air intake

9.2 VENTILATION SYSTEM

During operation, due to their surface temperature, the engines propagate radiant heat, which must be eliminated through efficient ventilation.

Air inlet and discharge openings are positioned so as to have the air flow passing through the whole room.

The yacht's diesel engines (propulsion engines and generator) suck combustion air directly from the engine room.

The external fresh air enters the engine room and the utility room through two inlets (air intakes) located on the bulwark on both sides of the yacht.

The air extraction is of the forced type, by means of three air extractors (1) (sucking fans) which extract the hot air from the rooms.

When the engine ignition keys are set to ON, the air extractors are automatically started.

In order to start the air extractors, in manual mode and with the ignition keys set to OFF, press the start/stop push-buttons located in the helm position.

The power supply of the extractors is controlled by the SHUTDOWN system of the fire fighting system that, in case of automatic fire extinguishing system activation, or when operating the tie rod, shuts down the air extractors in order to prevent air change in the room.

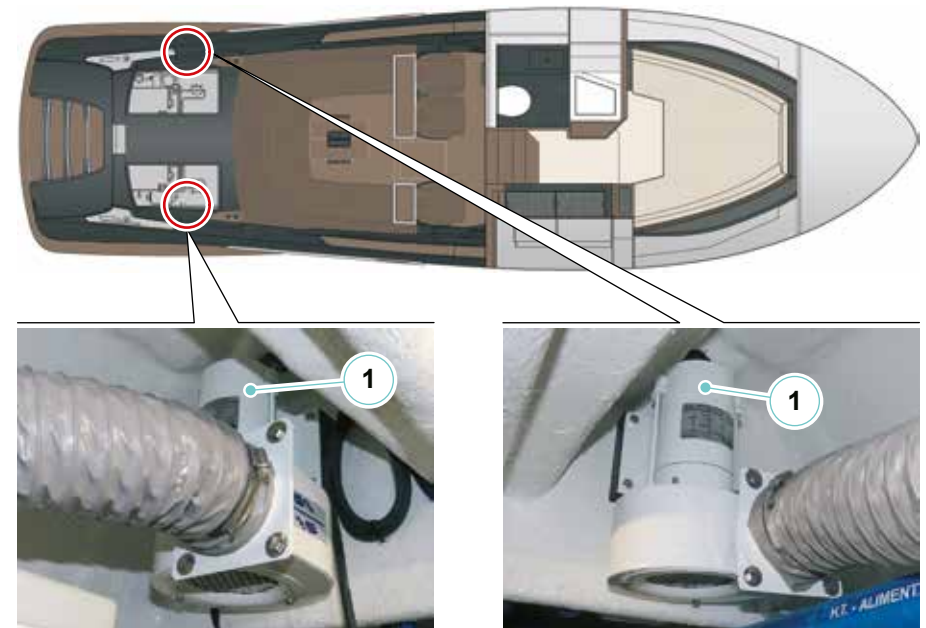

**CAUTION**

With the engines in operation the extractor must always be switched ON. It's suggested to keep them ON for at least 30 minutes, after switched OFF the engine, to eliminate the residual heat.

**DANGER****Carbon monoxide poisoning**

Fossil fuel combustion generates a high quantity of carbon monoxide. This gas is a colourless, odourless and highly toxic. When the engines and/or the generator are running, the yacht must be properly ventilated, in particular if underway at low speed, or when the exhaust fumes may blow back on board (e.g. when the yacht is shored or anchored or riding the anchor).

**CAUTION**



Do not place any type of equipment or clothing on the air extractors or in the air intakes, as this may damage the rotating parts of the electric extractors or obstruct the passage of air.

**CAUTION**

Do not accidentally obstruct the external grates with any objects (such as towels, etc..).

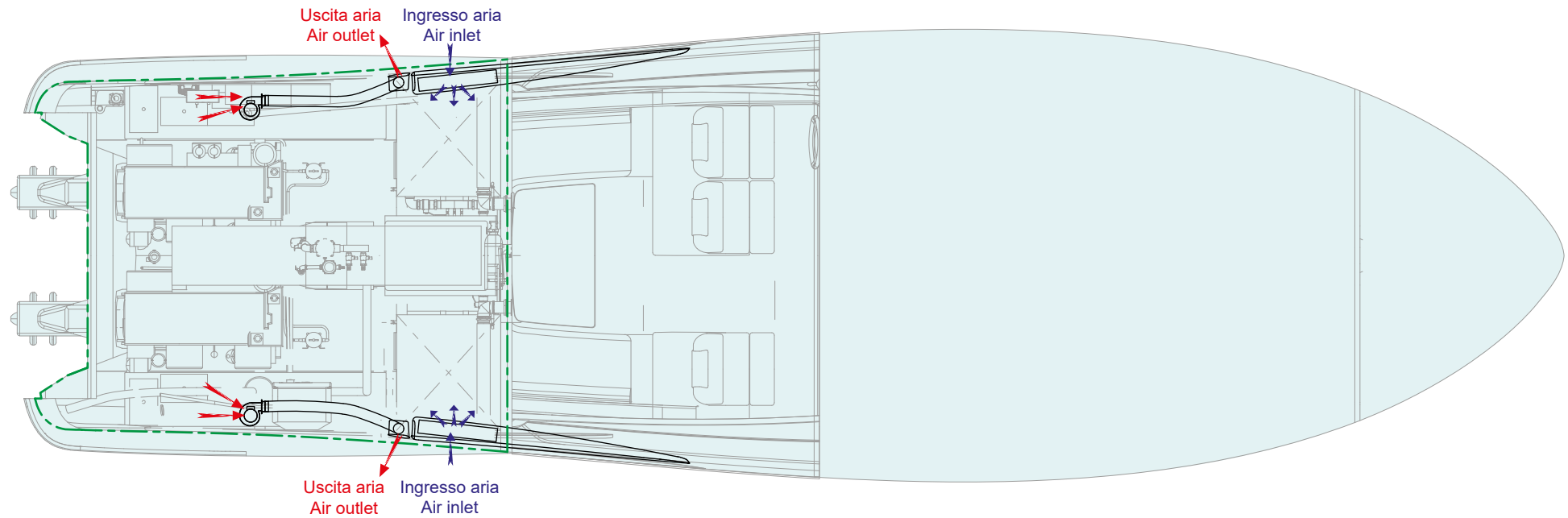
Ventilation system diagram



ICONA ICON	DESCRIZIONE DESCRIPTION
	Estrattore Extractor
	Tubo corrugato Corrugated pipe

ICONA ICON	DESCRIZIONE DESCRIPTION
	Linea uscita aria Air output line
	Linea ingresso aria Air inlet line
	Spazio protetto Protected space

Riva

RIVAMARE CENTO

AUXILIARY EQUIPMENT ON BOARD

CHAPTER 10

10.1 PREPARATION FOR MOORING

Your yacht is equipped with instruments necessary for easy and safe mooring. In addition to the windlass, the mooring equipment is located at the bow and stern and consists of:

- 2 mooring cleats at the stern of the yacht;
- The anchoring area at the bow tip contains:
 - One mooring cleat;
 - One deck fitting;
 - A locker containing the windlass.

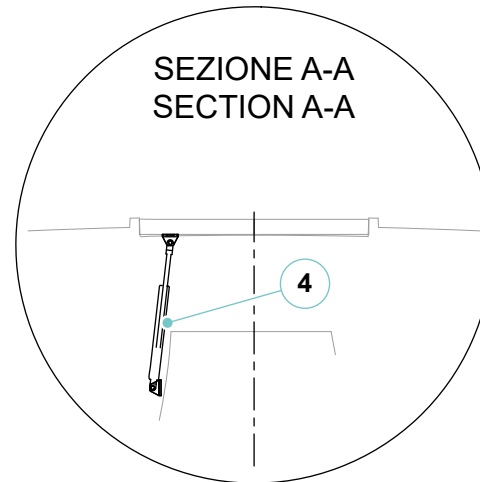
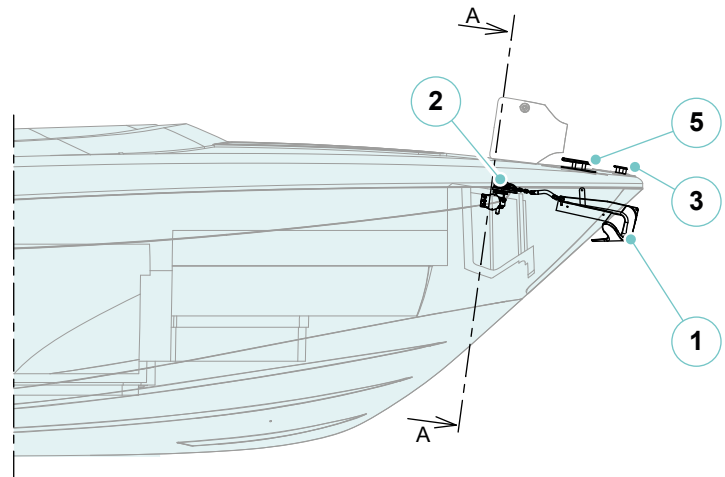

BOCCAPORTO CHIUSO
HATCH CLOSED

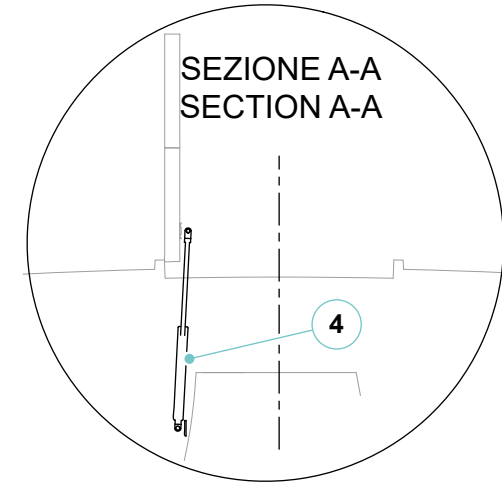

BOCCAPORTO APERTO
HATCH OPEN

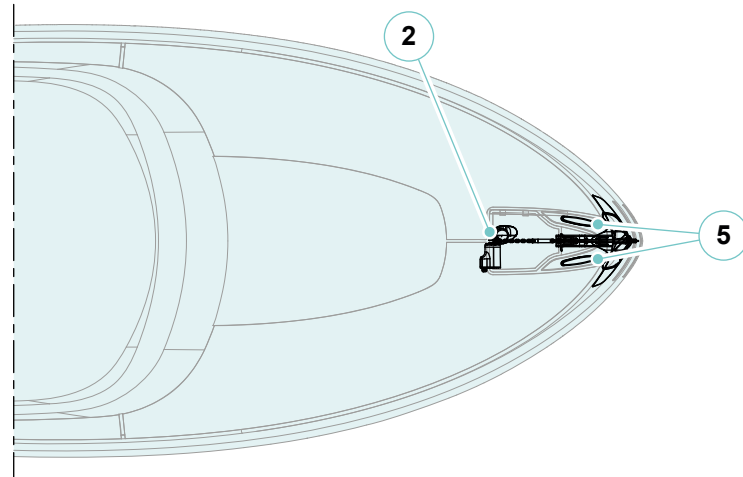

N° No.	DESCRIZIONE DESCRIPTION
1	Ancora Anchor
2	Verricello 12V Winch 12V
3	Passacime di prua Bow hook
4	Molla a gas Gas spring
5	Bitta di prua Bow cleat

10.2 ANCHOR WINCH

The yacht is equipped with an electric anchor windlass to drive the anchor housed in the bow.

The anchor chain enters the yacht and reaches the windlass, rides over the barbotin and enters the chain locker in the bow.

To power the winch it is necessary to activate the circuit breaker on the main electrical panel.

The windlass is equipped with a control for movement of the chain in both directions and a safety cable to lock the position of the chain when under way.



CAUTION

RIVA is exempted from any liability for any accidents or damage to persons or property caused by incorrect use of the device.

Anchor winch activation controls

It is possible to operate the winch positioned at the bow using the control button on the helm position or using the control panel located inside the bow locker.



CAUTION

If you intend to use the anchor, remove the chain lock safety cable.



CAUTION

Do not bring body parts or objects near the area where the chain, the line and the barbotin run.

Make sure the electric motor is not powered when acting manually on the anchor winch (also when you use the lever to loosen the clutch): people having the remote controls of the anchor winch (remote push-button panel) might accidentally activate it.



CAUTION

Lock the chain with its safety cable before setting up for navigation.



CAUTION

Do not operate the anchor winch electrically with the lever in the drum housing or in the barbotin cover.

Clutch use

The barbotin is connected to the main shaft by means of the clutch. The clutch opens (disengages) when the lever inserted in the bushing is rotated counterclockwise. When rotating clockwise, the clutch will close (engage).

Anchoring

The wind and the sea conditions highly affect an anchored yacht. Make sure the anchor is set in any situation. It is necessary to understand the principles of the chain length and its effect on the anchor performance.

The radius is technically defined as the ratio between the chain length and the vertical distance from the bow to the sea bottom.

The chain length depends on the type of anchor, on the sea bottom, on the tide, on the wind and on the sea conditions.

The chain length is 5 times the depth of calm sea; it is 7:1 in normal conditions and up to 10:1 in critical conditions.

$$\text{Radius} = \frac{\text{Chain length}}{\text{Bow height} + \text{water depth}}$$

as it is necessary to know the length of the chain to be used for mooring.

Chain length = (bow height + water depth) x radius

Anchor weighing

Start the yacht's engines. Make sure the clutch is engaged and pull out the lever. Press the control button available and start to weigh the anchor.

If the anchor winch stops without any reason, the anchor might be stuck and therefore the anchor winch thermal switch trips, due to the effect of the effort. In this case, if after several attempts the anchor winch remains stuck, we suggest to manoeuvre the yacht to release the anchor.

Check the raise of the last metres/feet in order to avoid bow damage.

Anchor lowering

Lower the anchor by means of the electric controls or manually. To carry out this operation manually, open the clutch and let the barbotin rotate freely on its shaft and the chain fall into the water. To brake the anchor chain fall, turn the lever clockwise.

To lower the anchor electrically, press the control button at your disposal. In this case the anchor lowering is perfectly controllable and the unrolling of the chain or of the line is regular.

Once the yacht is anchored, lock the chain with the safety cable.

The anchor and the chain may damage the yacht bow if the anchor winch is not operated carefully.

We suggest to carry out the operation by means of the remote control located near the anchor winch; this will allow checking the lifting and lowering speed of the chain and the entry and exit of the anchor shaft into the anchor roller.

Namely during those operations, an excessive gliding of the chain or a wrong entry or exit of the anchor shaft from the roller may cause damages to the yacht's bow.



DANGER

Do not use the on board auxiliary equipment for aims or ways other than those indicated in the manual delivered by the Manufacturer. Always deactivate the capstan winch when not in use to prevent accidental activation.



DANGER

Never get too close to moving parts to avoid danger and injury.

**CAUTION**

The anchoring area is a circle with the centre at the anchoring point and a radius equal to the chain length plus the yacht length.

The entire anchoring area must be free, in case of sudden variations of wind and/or current direction, especially in case of night anchoring.

At night, before dropping the anchor, check that the white anchor light works.

Before dropping the anchor, check the nautical charts: anchoring is prohibited in certain areas, in weeds covered sea bottom, anchoring is unsafe and harmful to the environment, on rocky sea bottom, the anchor may get stranded or lost.

Anchor the yacht with the engines running, both for safety reasons and to compensate the electrical consumption of the winch.

Check the anchoring point frequently.

The distance from obstacles or other yachts must be, at 360°, greater than the length of chain dropped.

During anchor riding it is advisable to leave the winch powered.

Do not reverse the winch rotation suddenly.

**CAUTION**

The anchor chain is fastened to the yacht by means of a line and an hook system. If it is impossible to remove the anchor from the sea bottom, this system will ease up to resume navigation.

**DANGER**

When the winch is operating, be extremely cautious of rotating parts; keep your feet, hands and the remote control cable at safe distance.

Anchoring operations

- Make sure that the engines battery breaker is ON;
- Start the main engines;
- Turn the anchor winch switch ON, on the main electrical panel;
- When the key-pad is not used, disconnect it to prevent contact oxidation;
- Before operating the windlass with the electrical control, ensure that the barbotin clutch is tight and remove the chain lock hook;
- Let the yacht move backward slowly; if necessary, use the engines;
- Lower the anchor until just below the waterline, and hold;
- Lower the anchor until it reaches the sea bottom;
- Once the anchor holds, leave the lock and the brake engaged.

**CAUTION**

Operate the anchor winch with the engines running, in order to provide the high current required and reduce the stress by slowly moving the yacht toward the anchor.

Lower and raise the anchor always by using the electrical control, after engaging barbotin and barrel. The latter can be released to drop anchor if necessary.

**CAUTION**

The chain lock must be correctly inserted when under way.

Weighing the anchor

To weigh the anchor, perform the same operations previously described above, in reverse order.

In case of wind or current, we recommend using the engines as an aid in maintaining the heading towards the anchor position to avoid damaging the bow.

Once the anchor is on board, fasten the chain stopper before resuming navigation.

**CAUTION**

Prior to departing, check that the chain stopper is properly fastened.

10.2.1 Anchor winch maintenance

Component	Maintenance	Notes and precautions
Reduction motor	Check and cleaning (before each navigation)	When you weigh the chain, after an anchor mooring in a muddy or weedy sea bottom, we advise you to wash the chain using the proper system. The outer part of the winch requires frequent washes with fresh water because very much exposed to sea salt during navigation specially with choppy sea.

Reduction motor



CAUTION

Before carrying out any maintenance operation on the anchor winch cut out electric power connected with it and remove with care the chain from the barbotin.



CAUTION

If the outside temperature is low, it is advisable to run the winch at idle (unloaded) for about a minute before use in order to warm the lubricating oil in the gear motor and increase fluidity.

Remove the layer of salt, which builds up on the anchor winch outer surfaces as soon as possible, to avoid dangerous corrosion, which could jeopardize its integrity.

Wash with fresh water and clean the surfaces, particularly those hidden and hardly reachable and into which the salt remains trapped.

At least once every two months disassemble the exposed parts, clean and check all pieces so that they do not show signs of corrosion and grease the thread of the shaft with sea grease.

In case of anchor winch long inactivity, we advise you to have the motor run idle for a couple of minutes in both directions.

If the electric motor turns with problems we advise you to clean or replace the brushes.

We strongly recommend to separate the anchor winch from the main deck at least twice a year to remove the salt deposits building up under the base.

10.3 GANGWAY

Your yacht is equipped with an electro-hydraulic aft gangway, for boarding the yacht from the shore. The movement is controlled by the synoptic panel of the helm position.

The electro-hydraulic control unit that controls the oil flow that allows moving the gangway by means of hydraulic cylinders is located in the starboard side of the technical room.

Each gangway is delivered with one remote-control units (Manufacturer advised you to required one as a reserve in case of loss).

The remote-control units are fragile electronic devices that must be kept in a dry place.

**DANGER**

NEVER start navigation if the gangway is not correctly retracted.

**DANGER**

The gangway, for boarding and leaving the yacht, shall be used only by one person at a time; make sure never to exceed the maximum capacity stated by the manufacturer.

Never operate the gangway when someone is passing on it; before activating it and during operation, make sure that no one is within its moving range.

When walking on the gangway, be cautious and keep hold to the handrail; as it is made of rope, it cannot be considered a rigid and safe support, but simply a help to keep balance.

NOTE

The gangway can be operated only with the hatch fully opened or fully closed.

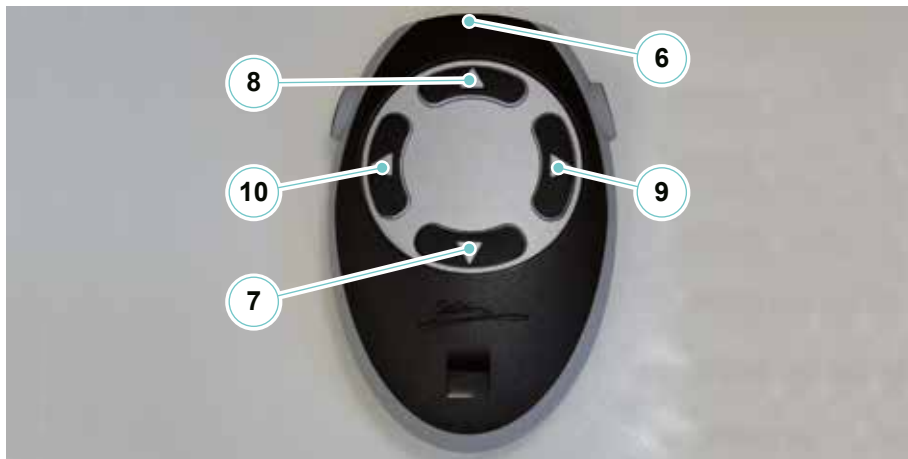
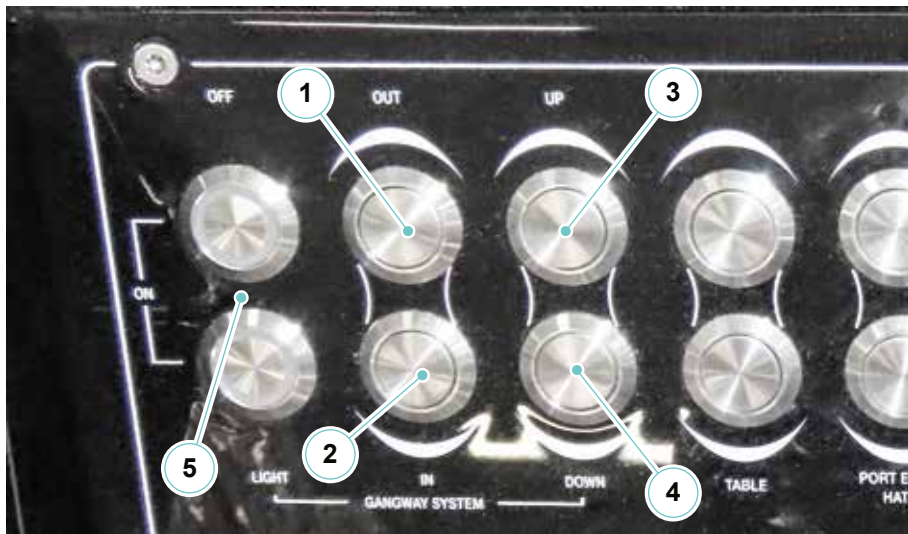

CAUTION

The hydraulic gangway, even if easy manoeuvrable, might damage people and things.
Its use is recommended only to well experienced people.

Telescopic movement buttons

1. Gangway extension
2. Gangway retraction

Gangway up/down buttons

3. Gangway lifting
4. Gangway lowering
5. Gangway lights activation

Remote controls

6. LED to confirm operates transmission
7. Operates the lowering of the gangway
8. Operates the raising of the gangway
9. Operates the retraction of the gangway and the autoalignment
10. Operates the extraction of the gangway

NOTE

The remote controls are supplied as standard and have an operating range of about 10 m (33 ft).

Manual operation of the electro-hydraulic control unit

To carry out the gangway motion by means of manual pump, proceed as follows:

- Go to the end of the desired solenoid valve and press the cap.
- Press and hold and activate the manual pump of the oil control unit in order to allow oil flow.

By shifting to the different ends of the solenoid valves you can perform all gangway operations manually.



CAUTION

In MANUAL mode it is necessary to constantly monitor the position of the gangway during movement since the end of stroke sensors are cut out to collisions and resulting damage to the system or yacht. It is necessary to check that the gangway is properly aligned with its housing in order to retract it.



DANGER

All operations must be carried out under the supervision of the operator.



CAUTION

Always pay the utmost attention to the movements of the gangway; in case of emergency, press any button of the remote control or of the panel to stop the gangway.

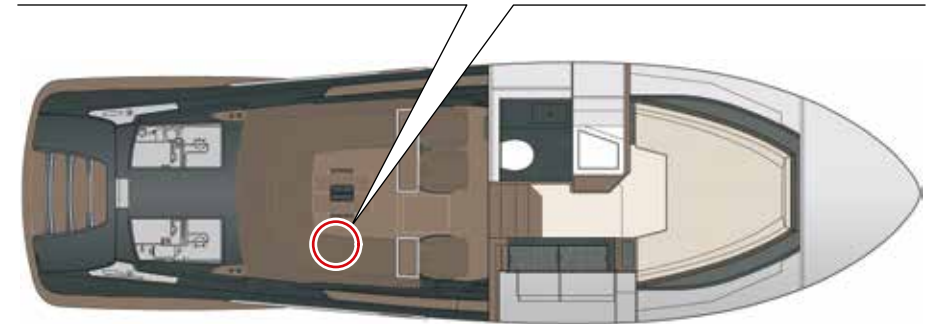

**CAUTION**

The hydraulic gangway, even if easy manoeuvrable, might damage people and things. Its use is recommended only to well experienced people.

**CAUTION**

Use and suggest to passengers comfortable shoes and eventually help them with the boarding.

**CAUTION**

RIVA declines all responsibility concerning tampering carried out by third parties on equipment installed in the Shipyard. Such tampering or unauthorized installations will not only immediately void the warranty, but may cause damage to the yacht and injuries to the people on board. RIVA declines all responsibility concerning periodical maintenance activities scheduled by the Shipyard or by Manufacturers, but not carried out, of equipment/components, for which it is necessary to refer to their own Technical Manuals.

**DANGER**

Never use the gangway to lift persons, even though the same is provided and tested to lift much heavier weights. Always make sure that the maximum load suggested by the Manufacturer is not exceeded (150 kg) [331 lb]. Never operate the gangway when someone is passing nearby. When walking on the gangway, be cautious and keep hold to the handrail; as it is made of rope, it cannot be considered a rigid and safe support, but simply a help to keep balance.

**CAUTION**

Do not use the gangway as a springboard.

**DANGER**

Never start navigation if the gangway is not correctly retracted. Make sure that the gangway, the swim platform hatch and the swim ladder are correctly closed, before undertaking the navigation.

**DANGER**

Pay attention to moving parts and to your hands.

**CAUTION**

Never use slippery products for the gangway cleaning.

**CAUTION**

Position the gangway in such a way that it cannot touch the shore, either because of the normal yacht swinging or of the tide change. Should the gangway strike against the shore, it could get seriously damaged.

**CAUTION**

RIVA declines all responsibility for any accident to persons or damage to property caused by a wrong use of the device.

MAINTENANCE

At least once a week carry out the washing with fresh water and an accurate cleaning.

At least once a month:

- Check the oil level in the control unit, when necessary top-up;
- Check the possible presence of oil leaks and bleeding;
- Check the operation of the emergency pump;
- Check the possible presence of corrosion;
- Grease the pulley gliding races of the steel cable.

At least once every six months;

- Grease the swivel pins and the gliding sleeves;
- Tighten the locking bolts.

NOTE

The check and maintenance operations must be carried out by skilled technicians, instructed about the control unit operating conditions.

NOTE

The spares must correspond to the requirements established by the Manufacturer, this is obviously ensured with the use of original spares.

**CAUTION**

Always previously announce the gangway manoeuvring when there are people on the shore.

NOTE

Always manoeuvre maintaining eye contact with the gangway.

**CAUTION**

Never manoeuvre the gangway when people are present on the shore within range of the gangway.

NOTE

For further information on use and maintenance, please refer to the manufacturer's manual.

PORTELLONE APERTO - VISTA FRONTALE
OPEN HATCH - FRONT VIEW

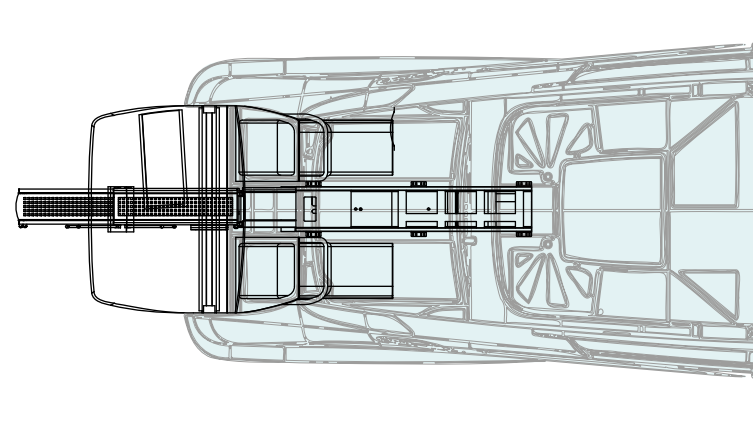
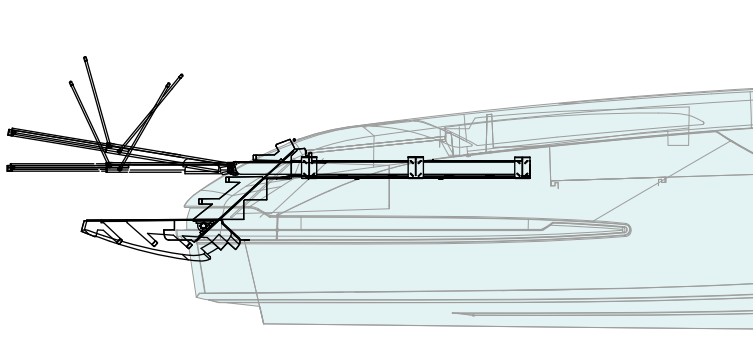

PORTELLONE CHIUSO - VISTA FRONTALE
CLOSED HATCH - FRONT VIEW

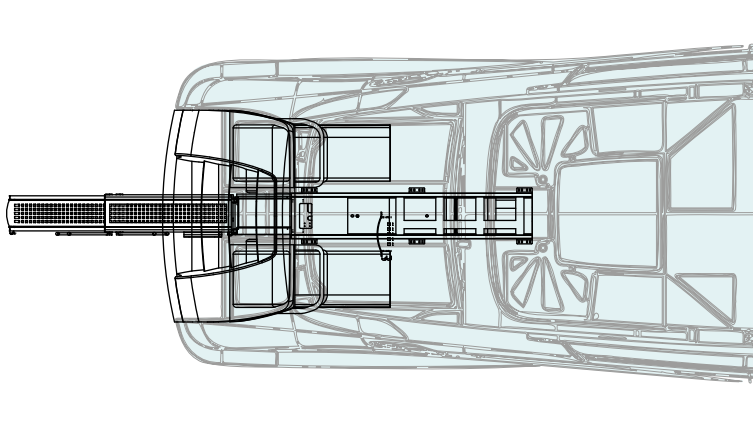
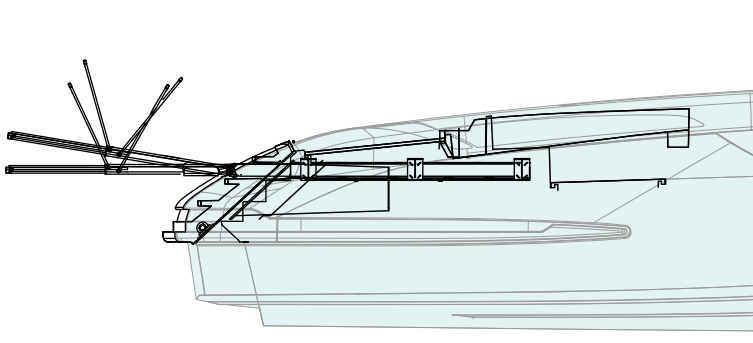

10.3.1 Gangway system maintenance

Component	Maintenance	Notes and precautions
Electro-hydraulic control unit	Oil top up	Check the oil level inside the tank every month and anyway before each navigation. Top up keeping the oil level at about three-quarters of the tank's capacity, and using the type of oil recommended by the Manufacturer.
Gangway	Cleaning	As this device is located in a very critical position compared to all other on-board equipment, being continuously in contact with water, salt and exhaust gas, they require a more accurate cleaning.



DANGER

During cleaning or maintenance operations, make sure that nobody can activate the gangway, they causing serious injury to persons, by cutting off power supply.



ENVIRONMENT

Do not discharge hydraulic oil in the sea, but in the special areas for toxic waste disposal.

NOTE

Improper use of the hydraulic systems, altering of the flow calibration, disrespect of manoeuvring procedures described in this manual relieves RIVA of all liability.

10.4 STERN PLATFORM

The yacht is equipped with a stern platform (1) which when fully open acts as a swimming platform function.

To move the stern platform use the "GARAGE" buttons (2) present in the helm position.

When the engine is switched OFF, the pushbutton lights up and remains illuminated while moving and until the hatch is closed.

When the engine is switched ON, pressing the "GARAGE" command will illuminate and a beeper will alert you that the hatch is open.

The movement are powered by a control unit (3) located in the technical room.

With the stern platform is open you can access the 2 compartments at the starboard side and port side of the yacht.

The compartment to starboard side can be contains a seabob.

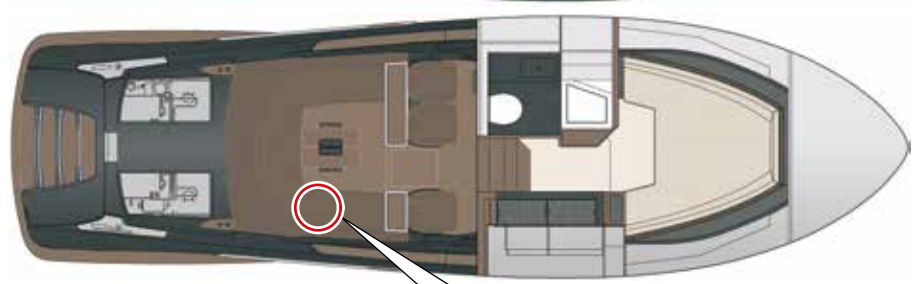

PORTELLONE CHIUSO
STERN PLATFORM CLOSED

VISTA FRONTALE
FRONT VIEW

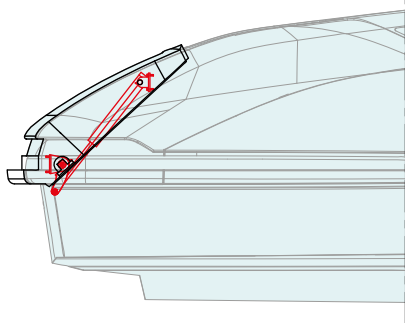

VISTA DA POPPA
STERN VIEW

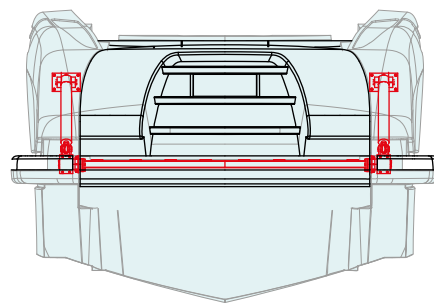

VISTA IN PIANTA
PLAN VIEW

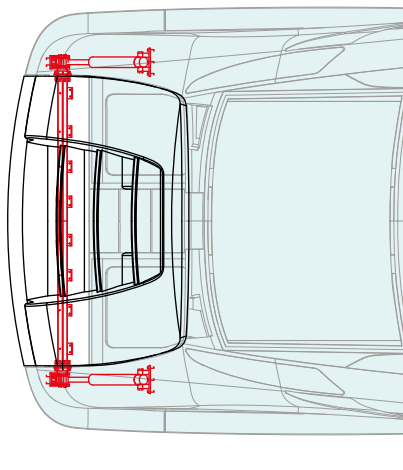

PORTELLONE APERTO
STERN PLATFORM OPEN

VISTA FRONTALE
FRONT VIEW

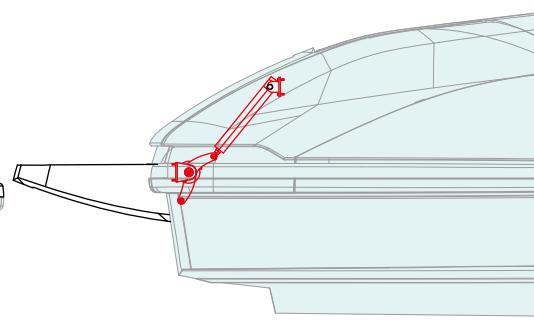

VISTA DA POPPA
STERN VIEW

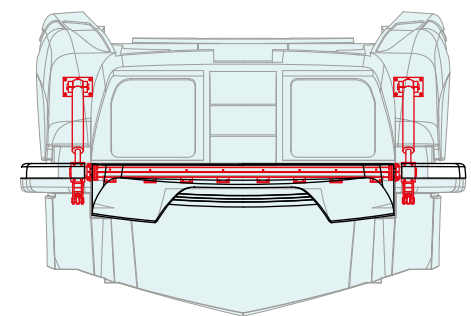

VISTA IN PIANTA
PLAN VIEW

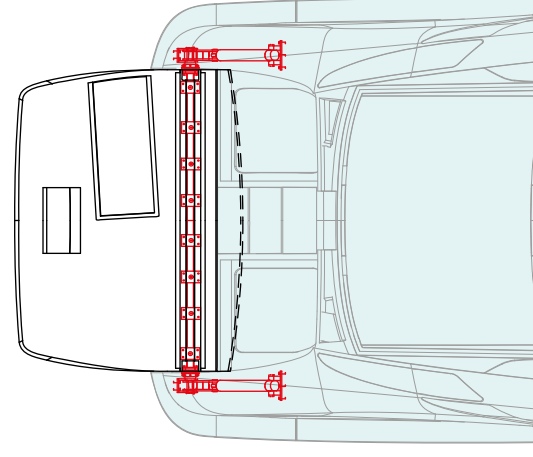

10.5 WINDSCREEN WIPER SYSTEM

To ensure proper visibility in all weather conditions, your yacht is equipped with an efficient windscreen wiper system.

The system is powered at 12V and the two wiper blades are operated by means of mechanical arms.

The windscreen wiper system is operated by a designated button on the helm position.

If you need to use the windscreen wiper system, you must first activate the circuit breaker on the main electrical panel.

10.5.1 Windscreen wiper system maintenance

Component		Maintenance	Notes and precautions
Windscreen wiper blades		Cleaning	Clean accurately with fresh water after each navigation return. Clean periodically the windscreen wiping blades using specific detergent or alcohol. Apply Vaseline oil on the blades and grease the arms springs with silicone grease.
		Replacement	Replace the windscreen wiper blades at least once a year with original spares. If necessary and if the blade rubber results to be deformed or worn out, replace them more frequently.



WARNING

During the cleaning or maintenance operation, make sure that nobody can operate the windscreen wiping system causing damages to persons.



CAUTION

Do not remove foreign bodies activating the blades when the windscreen is dry.



CAUTION

With very harsh weather, and with the freezing risk, detach first the wiping blades from the windscreen surface.
Before activating the windscreen wiping system make sure that ice has not stuck the blades on the windscreen surface; if necessary to spray an anti-freezing agent to detach them.

10.6 BIMINI

Your yacht is equipped with an electrohydraulic bimini to provide shelter for the cockpit area.

The electrohydraulic unit that controls bimini movement is located in the technical room.

To open/close the bimini, activate the relevant circuit breaker on the main electrical panel.

The bimini is moved by pressing and holding the button on the helm position; movement is accompanied by an acoustic signal.

NOTE

Do not use products containing solvents to clean the bimini canvas as these may compromise the canvas surface treatments.

NOTE

The function of the bimini is to provide protection from the sun; remove any water deposits that may form on the bimini immediately. Any water remaining between the mounts for an extended period of time can cause dirt and the permanent deformation of the fabric due to the added weight.

**CAUTION**

During bimini positioning, guests must remain seated on the sofas of the cockpit to avoid the possibility that any loss of balance might lead them to grab parts of the bimini not designed to resist abnormal stresses.

**DANGER**

During the opening / closing phase, the captain must take care to ensure that guests are not present in hazardous areas, particularly within the bimini's range of motion.

**DANGER**

Release the bimini completely by holding down the appropriate button and stop only in case of emergency or hazard.

**DANGER**

Be careful not to place hands in the bimini cavity during closure.

**CAUTION**

Never open the bimini during navigation.
Only open when the yacht is stationary so as to avoid a "sail effect", which could damage the structure or cause injury to persons.
Do not open the bimini in adverse weather conditions.

**CAUTION**

Never press the bimini closing button without removing the fore and aft fastening straps.



CAUTION

When washing the yacht, never direct high-pressure water jets onto the canvas surfaces as doing so may deform the seams.

NOTE

For further information on use and maintenance, please refer to the manufacturer's manual.

BIMINI CHIUSO
CLOSED BIMINI

BIMINI APERTO
OPEN BIMINI

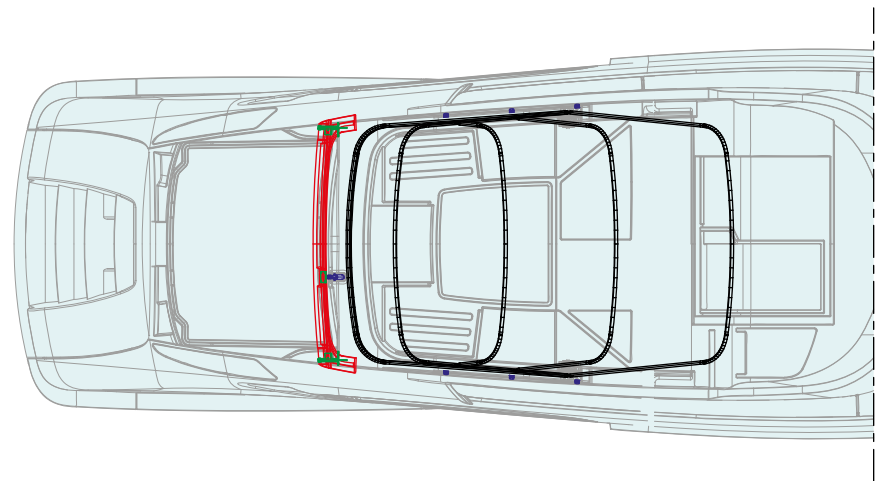
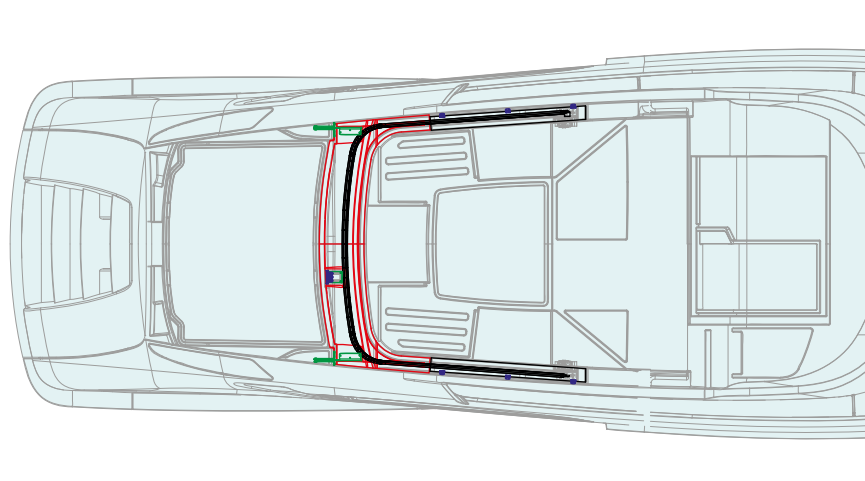
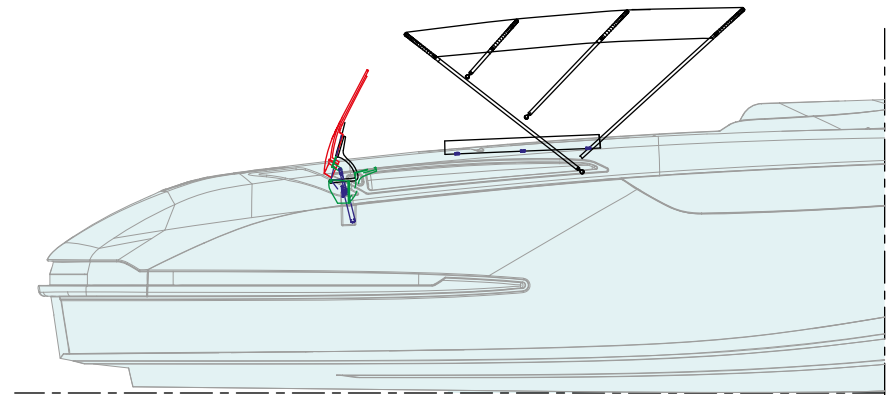
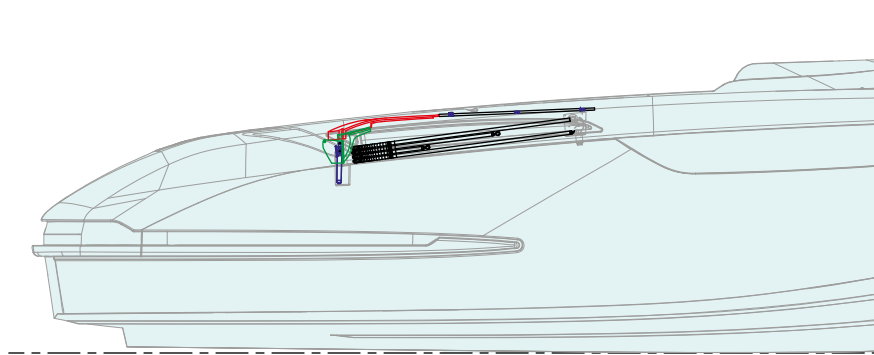

10.7 COCKPIT TABLE

In the stern cockpit there is table that can be adjusted in height using electric actuators.

The table controls are located on the synoptic panel of the helm position.



DANGER

Moving parts: be alert, always keep hands and feet at a safe distance. Do not insert any object between the structure and its seat.



CAUTION

Do not sit on the table while it is in motion.
This could compromise the functioning.



DANGER

During cleaning or maintenance operations, make sure that nobody can activate the table, because this can cause heavy injuries to persons; we recommend disconnecting the electric power supply.

NOTE

For further information on use and maintenance, please refer to the manufacturer's manual.

10.8 SWIM LADDER

The yacht is equipped with a swim ladder which allows easy access from the sea to the stern platform, and vice versa.

The swim ladder is placed inside the stern platform structure, in order not to cause obstruction during navigation.

For the swim ladder extraction proceed as follows:

1. Open the stern platform;
2. Turn the ladder block (1) to release it;
3. Pull the ladder (2) from its seat.

The swim ladder does not require ordinary maintenance; anyway, being particularly exposed to sea corrosion, it is advisable to wash it accurately with fresh water after each use.

Inhibition sensor limit switch manual ladder and acoustic alarm

To extract the manual swim ladder located inside the hatch, the hatch must be opened.

When the swim ladder is removed, a position sensor prevents the closing of the hatch to avoid damaging the yacht.

In the case the sensor has a malfunction and inhibit the closure of the hatch, in the engine room has been installed a sensor by-pass command that allows to close the hatch after checking the effective closure of the swim ladder:

- A person must to monitor the progress of the movement to avoid possible interference between the swim ladder not completely closed and the closing seat of the aft hatch.
- The activation of the sensor by-pass command is signalled by an acoustic alarm which remains constantly active until the by-pass command is deactivated.



**CAUTION**

Make sure that the swim ladder is correctly extracted and positioned before going down to water.

**CAUTION**

Never use the swim ladder when the engine is running.

**CAUTION**

Pay attention because the ladder can be slippery. Ensure a safe grip before reboarding.

**DANGER**

Pay attention to moving parts and to your hands.

**DANGER**

Risk of electric shock from leakage currents. Never swim in waters near harbours or marinas.

**DANGER**

Never start navigation with the swim ladder not correctly retracted and locked.

**WARNING**

For a safe use of the yacht, when you are stopped at open sea and you are alone on board, always keep the swim ladder open.

SCALA BAGNO CHIUSA
CLOSED SWIM LADDER

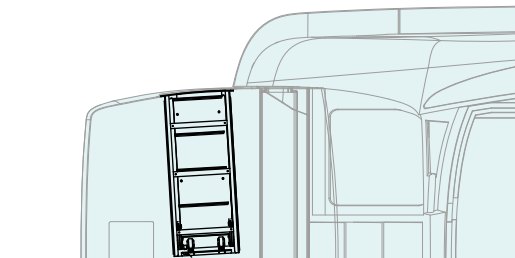
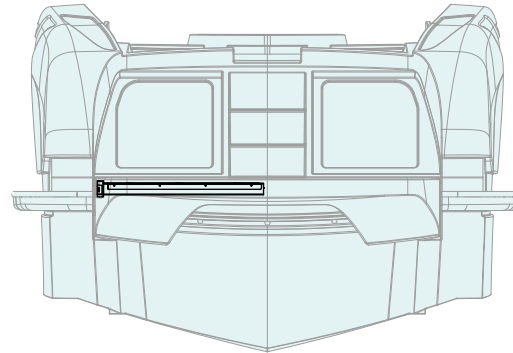
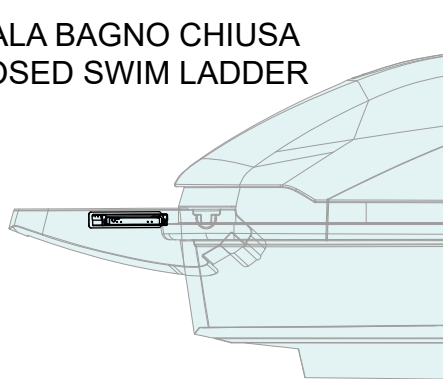

SCALA BAGNO APERTA
OPEN SWIM LADDER

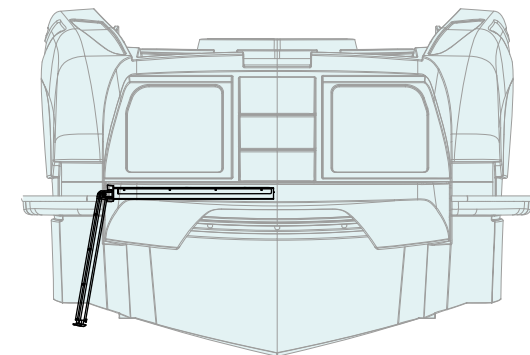
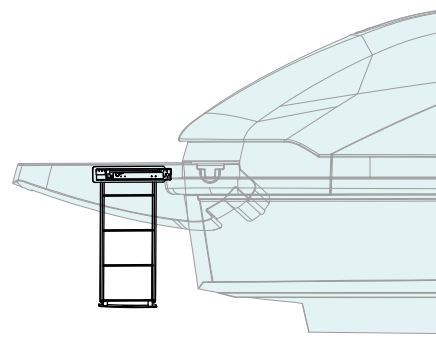
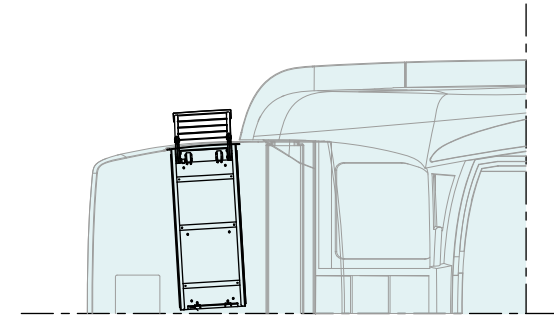

10.8.1 Swim ladder maintenance

Component	Maintenance	Notes and precautions
Swim ladder	Cleaning	The swim ladder are located in a particular position compared to all other on-board equipment, because they are continuously in contact with water, salt and exhaust gas, they require therefore a more accurate cleaning.



CAUTION

RIVA declines all liability for any accident to persons or damage to property caused by a wrong use of the device.

Riva

RIVAMARE CENTO

INFORMATION FOR USE

CHAPTER 11

11.1 GENERAL INFORMATION

This part of the manual describes some basic rules to keep in mind at all times in order to enjoy your yacht safely.

- Make sure that safety equipment is perfectly efficient and available to each passenger.
- Keep a safe distance.
- Check that all yacht safety equipment on board is in good condition and no maintenance activity is overdue.

NOTE

The manufacturer provides some of the international equipment required the owner will have to equip the yacht with devices required by national laws.

- In case of using the fixed fire-fighting system: do not ventilate the engine compartment, until the fire has been completely extinguished.
- Ventilate the engine compartment before entering. Ventilate the lower deck compartment before entering, if portable extinguishers have been used.
- When operating the gangway, be sure that nobody is in the way.
- Oils, used filters, emulsions, coolants and electrolytes are all harmful products: avoid contact with the skin and dispose of them carefully.
- In the engine compartment, be cautious with hot and moving parts.
- Wear hearing protection when entering the engine compartment.
- Do not use open flames and do not smoke, when handling fuel or lubricants.
- Do not scatter fuel in the environment.
- Change the fresh water in the tank frequently and treat with bactericides.
- Do not exceed speed limits in harbours or confined waters.
- Reduce speed in the proximity of other yachts or swimmers.
- Adjust speed according to sea conditions.
- Reduce speed before entering the engines room. Modify the course, if necessary.

- Before connecting the shore power socket, make sure that the switches on the panel in the engine compartment are not activated.
- Before leaving the yacht, turn the battery breakers OFF.
- Handle hot oils carefully, in order to prevent serious burns.
- Do not work on engines, shaft lines and generator without first disabling their start-up.
- Do not inhale exhaust fumes: risk of serious injuries or death.
- Do not work on generator electrical panels when the generator is running: electrocution hazard.
- Before disconnecting a battery, check if the battery charger is operating. If it is, disconnect it and remove the negative wire first and then the positive one. When reconnecting the battery, follow the same steps in reverse order (the positive wire first and then the negative one).
- Replace any part showing signs of corrosion immediately.
- Do not disconnect the batteries while the generator or propulsion engines are running.



DANGER

The responsibility for the operation of each boat lies solely with the owner. It is the Owner's direct responsibility to ensure, prior to departure, that the safety equipment required by law is present on board and fully functional.



DANGER

We recommend that you read the safety instructions in this manual carefully before you set off on your voyage and before operating the various on-board devices.

11.2 PRECAUTIONS FOR HARSH CLIMATES

Regularly check that all equipment and machinery containing water is protected with the correct proportion of non-toxic antifreeze.

If the outside temperature is below or close to 0°C (32°F), the fresh water and sea water systems run the risk of freezing.

Piping and hoses may break from freezing and this could lead to the yacht sinking.

Systems prone to freezing also include freshwater and saltwater cooling systems.

For more information on the maintenance and service requirements of your yacht and its equipment, and for special information about maintenance in cold weather, see the sections in this manual that refer to the single components, devices and equipment, but be sure to consult the User Manuals provided by the Manufacturers for specific information.

11.2.1 Cooling system

The antifreeze liquid is advised for all kinds of climates: it increases the working temperature range, lowering the freezing point and increasing the boiling point.

When the temperature comes close to 0°C (32°F) it is necessary, in order to avoid the risk of freezing, to make sure that the cooling lines are filled with antifreeze mixture. If not, replace the cooling liquid with such a mixture.

Before filling the system with antifreeze mix, it is necessary to wash the cooling circuit.

Engine cooling systems should be filled with a mixture of 60% water and 40% antifreeze throughout the year to ensure protection against corrosion and freezing down to -27°C (-17°F).

At the beginning of the cold season, the antifreeze content of the coolant must be checked and increased according to the expected outside temperatures.



ENVIRONMENT

Concentrated coolant must be treated as special waste.

When disposing of used coolant, abide by the regulations of the local authority.

NOTE

For information concerning the type of anti-freeze or additive to be used, please refer to the technical documentation supplied by the Manufacturer.



CAUTION

Do not use only water as a cooling liquid, as it is corrosive at the engine operating temperatures and does not protect suitably against boiling and freezing.



CAUTION

We recommend you to use technical liquids approved by the system Manufacturer. Always avoid antifreeze concentration to drop below 40% in volume. Replace the whole cooling liquid according to the schedule indicated by the Manufacturer.

11.2.2 Fuel system

With low temperatures, diesel fuel can form some solidified paraffin suspensions which can clog the fuel filters; making the normal engine supply impossible.

Fuel as per European standard EN590 guarantees fluidity up to 0°C during the summer period, and up to -20°C during the winter period.

**WARNING**

There is a special type of fuel for countries subject to very low temperatures.

**CAUTION**

Do not add petrol to fuel, in order to avoid serious engine damage.

NOTE

For further information on use and maintenance, please refer to the manufacturer's manual.

11.3 PREPARING FOR NAVIGATION

Preliminary checks

Below are some important points to consider when preparing for departure:

- Check that the safety equipment on board is operational, in good condition and conforms with the regulations of the place of destination;
- Check that the bilge pumps on board are working properly;
- Check the cleanliness of the seawater filters; if they are dirty, close the seacock valves at right angles to the pipe, remove and clean the traps, reinsert them by carefully closing the filters, then reopen the seacock valves.



CAUTION

After reopening the valves, check that there are no leaks.

- Check the tension of the V-belts on the motors; restore correct tensioning if necessary;
- Check the engine, inverter and generator oil levels; top up if necessary;
- Check the engine and generator coolant levels; top up if necessary;
- Check the cleanliness of the fuel system separator filters;
- Check the hydraulic oil levels; top up if necessary;



CAUTION

To check and top up fluids, please refer to the specific manuals provided by the manufacturers.

- Check the liquid levels (fuel, freshwater) in the tanks;
- Check that moving parts on deck and below deck are properly secured;
- Check that the load distribution is such as to maintain the correct trim of the yacht.



DANGER

The owner of the yacht must ensure that all persons on board are familiar with the location of the safety systems (fire extinguishers, life raft, life jacket, etc..) and the correct way to use them.



DANGER

It is advisable to always carry out safety equipment checks before each voyage; these checks are useful not only for checking the condition of the equipment but also for memorising the locations and procedures for use. This short task may prove very useful in case of need.

- Check the operation of the stern drive.
- Check the operation of the interceptor.
- Operate both interceptors. When not in use, these should be left in the neutral position.
- Check that the navigation lights are switched ON and the horn is working.
- Check the proper function of the anchor windlass.
- Check the efficiency of the on-board instrumentation.
- Check the hatches are closed.
- Check the operation of the bilge pumps and their indicators.
- Ease the yacht's moorings and check that there are no obstructions to unmooring.

- Check that the engine compartment extractor is operational.
- Check that no inflammable or improper materials have been stowed in the engine compartment.
- Check that the sea inlet valves for engine cooling, generator, air conditioning and fire-fighting system are open.
- Check that the engine and generator cooling circuits are in operational mode (valves open).
- Check that the engine and generator fuel circuit is operational (valves open).
- Start the generator and, after a few minutes of pre-heating, give the electric charge to the generator by activating the utilities from the main control panel.
- Disconnect the shore power socket.
- Engage the engine and service battery breaker switches.
- Check the charge status of the batteries via the electrical panel; recharge if necessary.
- Engage the 12V utilities on the electrical panel.
- Disconnect unused utilities, after ensuring their correct operation.
- Start the engines with the throttle in “neutral” position.

**CAUTION**

The battery charger must be switched OFF when the engines are running.

11.3.1 Weather

Learn to understand weather patterns and signs of change.

Bad weather and sea conditions can cause an uncomfortable and unsafe situation.

Here are a few basic weather-related rules:

- Check the forecast and sea conditions before leaving and while underway;
- A sudden change in wind direction or speed, or an increase in wave height indicates deteriorating weather;
- If a storm approaches, immediately seek a safe harbour;
- If a storm hits, head the bow of your yacht into the wind;
- If you encounter fog, determine your position, set a safe course, slow down and alert other boats of your presence with a sound signal.

11.4 FIRST PERIOD OF USE

During the first period of yacht operation, in addition to the normal maintenance and check operations indicated in this manual, we recommend carrying out the following additional operations and more accurate checks.

The duration of this period varies according to the frequency and use modes, but are in any case suitable to allow a correct run-in of all systems and components on board.



WARNING

We recommend consulting the technical documentation provided by the Manufactures of the various on-board systems and components; they can indicate operations, checks and specific times not included in this Manual.

Following the first period of use, the hereunder listed additional operations and checks, should be performed at longer time intervals, although in any case, they play an important role for the safeguarding and reliability of the yacht and navigation safety.

- It is recommended that new or overhauled engines should not be operated above 75% of their maximum load and at variable speeds. After this initial run-in, the engine should be brought up to full output gradually.
- After starting each engine, check for the correct circulation of the cooling water inside the circuit.
- Before the engines start, check the correct tension of the V-belts.
- Check the possible presence of unusual noises from the engines exhaust.

- During navigation monitor constantly the temperatures and operation pressures of the devices on board.
- Check, by means of indicators installed on the electrical panel, the correct charge condition of the batteries starting the engines and the utilities. Moreover, the engine alternators must correctly charge the batteries.
- Check the efficiency of the stern drive and interceptors.
- Before and after navigation, check the correct oil level in hydraulic systems.
- After the generator start, wait several minutes before loading it. Bring it slowly to maximum performance monitoring its correct operation.
- Check the correct load level of all extinguishers (fixed and portable) installed on board; the indicator needle on the pressure gauge should be set in the green range.
- Check the indicator of the main pressure gauge for possible pressure drops inside the system.
- Before and after navigation, check the correct operation of all bilge pumps on board.



DANGER

Before performing the listed checks and maintenance operations, we recommend carefully reading the Safety Rules relevant to maintenance, contained in this Manual.



WARNING

Should more or less serious faults be noticed, contact the RIVA After Sales & Service Department as soon as possible.

**CAUTION**

RIVA declines all responsibility regarding tampering carried out by third parties on equipment installed in the Shipyard. Such tampering or unauthorized installations will not only immediately void the warranty, but may cause damage to the yacht and injuries to the people on board.

RIVA declines all responsibility concerning periodical maintenance activities scheduled by the Shipyard or by Manufacturers, but not carried out, on equipment/components, for which it is necessary to refer to their own Technical Manuals.

11.4.1 Engine drive

Despite the yacht's efficiency and high performance, the use of this yacht requires careful and responsible conduct.

The minimum gliding speed is influenced by the displacement, the distribution of the weights on board, the position of the interceptors and the conditions of the sea. An excellent compromise between transfer speed, comfort and consumption is obtainable with about 1500/2000 rpm less than the maximum allowable revolutions.

Do not keep the propulsion engines at idle for a long time; in this way they do not become "dirty" or overheated.

Avoid harsh accelerations or decelerations to avoid excessive stresses for the engine turbines.

When the yacht reaches the cruising speed, the engine check instruments should set to constant values.

If the instruments show contrasting or abnormal indications during continuous run, check for failures of the systems or of the equipment and contact RIVA After Sales & Service Department.

**CAUTION**

Set the speed of the yacht and the interceptors position according to the conditions of the sea and the prevalent direction of the waves; in this way the structure of the yacht does not undergo to useless stresses and the passengers can enjoy more comfort during navigation.

In the passage between displacement and gliding navigation there is a critical phase to be carried out as quickly as possible, as it is characterized by high consumption and more vibrations; it also causes a very deep wake.

**DANGER**

It is absolutely forbidden to perform reverse run with one of the two engines stopped.

This operation is allowed only in case of life danger for the persons on board and for the safety of the yacht itself, however when the engine is running it should not run higher than 1000 rpm.

**WARNING**

Avoid prolonged use of engines at low speeds to avoid overheating of the exhaust pipes due to reduced cooling water circulation.

11.4.2 Refuelling

Fuel must be loaded through the fill inlet located on the starboard side.

The filler cap is marked "DIESEL" to prevent the accidental introduction of improper liquids.



CAUTION

Gravity refuelling and not pressure refuelling should be used to avoid damage to the system.

Before loading fuel:

- Shut down the engines and generator.
- Prevent access to the area near the fill inlet and vents.
- Have a fire extinguisher and hydrocarbon absorbent material at hand.
- Wet the area near the fill inlet with water.
- Check that the vents are free.
- Determine the required amount of fuel to be loaded.
- Open the lid of the fill inlet.
- Check that the supply pump is of suitable size.
- Insert it into the fill inlet, holding it firm.

During refuelling, air vents must be monitored to ensure that there are no accidental fuel leaks due to the formation of foam or air pockets. When refuelling is almost complete, it is advisable to proceed with frequent breaks to allow any foam to dissipate.

Once refuelling is complete, screw the fill inlet cap back in and use absorbent material to dry any fuel droplets that may have leaked.

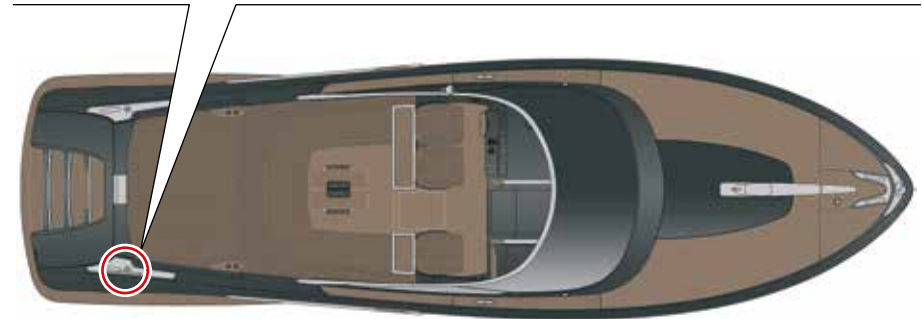

**ENVIRONMENT**

Do not dispose of fuel in the environment to avoid causing pollution. Dispose of waste contaminated by fuel in accordance with applicable regulations.

**DANGER**

Fuel leaks create a fire and explosion hazard.

**CAUTION**

It is suggested that you refuel upon returning to port to allow the fuel to cool down without forming condensation. Bleed the tank after every 2 or 3 refills.

**CAUTION**

Stop engines and generator when refuelling.

**CAUTION**

For the type of fuel to be used, follow the manufacturer's recommendations. Diesel engines require very clean fuel. Keep filters clean.

**DANGER**

The fuel is flammable and explosive.

During refilling:

- Smoking is prohibited.
- The use of naked flames is prohibited.
- Mobile phones must be switched OFF.
- Do not leave the yacht unattended.
- Do not leave the propulsion engines and generator running.

Failure to comply with these precautions may result in fire with the risk of serious damage to persons or property.

11.5 WATER SUPPLY

Proceed as follows:

- Ensure the yacht is properly moored; we suggest stopping the engines, if running.
- The water supply nozzle is located at port side of the yacht.
- Loosen the filler cap and insert the hose (it must have suitable dimensions).

At the end of filling, remove the hose and tighten the filler cap.



CAUTION

Frequently change the water in the fresh water tank and disinfect it with suitable products if necessary. Avoid leaving the tank completely full if there is a risk of freezing.
Do not leave the yacht unattended while filling.



CAUTION

The filler cap is marked "WATER" to avoid accidental introduction of different liquids.
To avoid damage to the system and tanks, we recommend replenishing by gravity and not by pressure.



CAUTION

Before refilling the fresh water tank, check that the water coming from the shore system is drinkable.

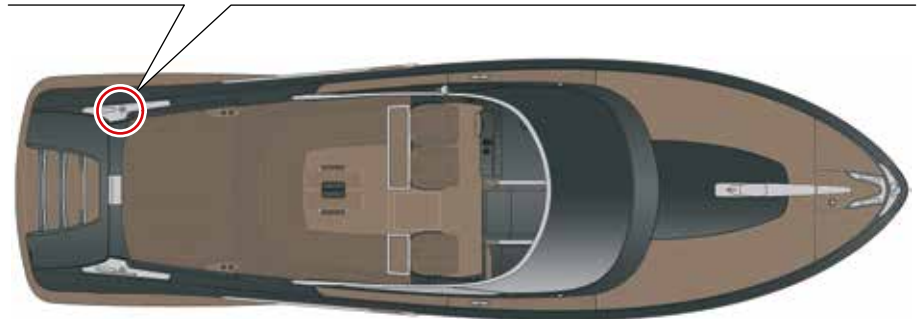

11.6 MOORING AND UNMOORING



CAUTION

Before starting the unmooring manoeuvre, ensure that engines, stern drive, rudders and bow thruster are working properly. During such manoeuvres, the Captain should prevent any unpleasant noise, and/or wake that might bother other people. Before unmooring, make sure that all doors, hatches, etc., are closed.



WARNING

Before starting the manoeuvre, make sure that people on board, especially children, do not obstruct operations and that they stay in suitable places.



DANGER

Check with extreme care that no one on board is in danger (with legs or arms outside the edge, in precarious balance or moving on wet or slippery surfaces) and that the fenders are well positioned and fastened.

The thruster must be used at a very low speed or without overheating; at a higher speed, more precise reactions are obtained with the staggered use of the engine throttle.

The ability to exploit these excellent qualities depends mainly on the “familiarity” the Captain has with his yacht.

Manoeuvre at a reduced speed to allow the necessary reaction time, so that you can better assess the situation at any given moment and, in the event of unforeseen circumstances, to avoid damaging your yacht or those of others.

Before unmooring check following:

- There should be no other boats manoeuvring;
- The mooring lines must not be snagged;
- The fenders should be in place and well secured (in the event of wind or undertow, equip a passenger with fenders to avoid damage);
- There must be no floating objects or loose lines that could damage the propellers;
- The shore power cable must be disconnected and stowed.

11.6.1 Leaving the mooring

The yacht is steered by turning the wheel, which moves the stern drive. If necessary and/or when manoeuvring in restricted waters, the yacht can be manoeuvred using the engine.

Bear in mind that the effect of the rotation of the stern drive is proportional to the propeller rpm and the yacht's momentum, and particularly in forward gear; as a result, with high rpm and high speed, the effect of the rudder is high, while with engine in neutral and low draft, the rudder angle reaction is greatly reduced.



WARNING

Before casting off the mooring, disconnect the cable connecting to the shore charging point.



CAUTION

It is the Owner's/the operators' responsibility to make sure that the mooring ropes, the towing ropes, the anchor chain, the anchor lines and the anchor are suitable for the intended use of the unit, i.e. the resistance of the ropes or chains must not exceed 80% of the resistance to breaking of the relevant strength point.

11.6.2 Mooring manoeuvre

Before returning to port, stop in open water and test the stern drive and thruster. Also check:

- The mooring lines and fenders must be ready for use;
- That the mooring berth and the berthing course are free from incoming, leaving or moored yachts or yachts with the signal of unsteered yacht at shore;
- Check that on the main electrical panel, all necessary uses are supplied. Disconnect unnecessary uses;
- That interceptors are lifted;
- That the yacht hook is easily accessible and does not hinder any passage;
- Check the operation of the audible warning devices;
- In case of at-night mooring, have a torch light (possibly operating) handy;
- That the passengers will not interfere with operations and, if participating, they know whom to listen to and what to do;
- That bilge are empty;
- That mooring ropes and fenders are correctly arranged.

If the yacht is moored with the stern towards the shore, tug on the stern lines and on the deadweight until it approaches the shore.

If the yacht is moored side on, tug on the bow and stern lines so as to approach parallel to the shore.

Once moored:

- Stop the engine;
- Make sure the lights on the helm position are switched OFF;
- Turn OFF any unnecessary electrical utilities and check the general configuration of the electrical panel;
- Check the proper operation of the bilge pumps;
- Stop the generator once the necessary cooling time has elapsed;
- Check bilge and dry it;
- Rinse the yacht with fresh water;
- Connect shore electric power supply.

Before leaving the yacht, check following:

- Lower deck lights are not powered;
- Ensure that navigation lights and external lights are switched OFF;
- Ensure that the anchor light is powered;
- Ensure that unnecessary devices are not powered;
- Ensure that devices in use are powered; (bilge pumps);
- Ensure that the shore plug is properly connected and the cable cannot be damaged;
- Disconnect battery breakers;
- Make sure that the devices (life jackets, yacht hook, torches, etc..) are in their correct positions;
- Ensure that all bottles and containers with flammable liquids are properly sealed;
- Make sure that no food residues are left around (they could rot or clog scuppers etc..);
- The gangway is in the right position and properly fastened;
- Ensure that mooring is correct (in case of bad weather conditions, tighten the mooring lines as much as possible and check the distance from other yachts is appropriate; ensure fenders are properly fastened, etc..);
- Ensure that sea water intakes are closed;
- That lower deck compartments are properly closed;
- Ensure that engine compartment hatch is closed.

11.6.3 Mooring without people on board

If the yacht is moored and left unguarded, operate as follows:

- Close sea cocks and overboard drain valves of sea water circuits.
- Check the condition of the electrical panel and disconnect all unnecessary uses.
- Ensure that all portholes and hatches are closed in all areas on board.
- Ensure that the mooring is in appropriate safety conditions.
- Ensure that the bilges are clean.
- Check that the grey and black water tanks is empty.
- Ensure that the fuel suction lines are shut OFF.



CAUTION

The electric power supply from shore must be disconnected, especially if the yacht is left unguarded for a long period.

It is necessary to recharge the batteries periodically.

Overboard outlets and drain pipes should be regularly checked, in order to ensure good buoyancy.

The electric system should be regularly checked, in order to prevent fires on board.



CAUTION

Inform the harbour arrangement manager of the on-board fire extinguishing system.



CAUTION

Disable the yacht's autoclave.

11.7 OPERATION AND PRECAUTIONS AT SEA

- During navigation do not unlock the chain stopper because you can seriously damage the yacht bow.
- Maintain a safe speed for the sea conditions, visibility, and when near other yachts.
- Do not exceed speed limits in harbour and confined waters.
- Follow all navigation rules applicable to the waters in which you are operating.
- Obtain plastic laminate reference cards for the Navigation Regulations and keep them handy on the helm position.
- Consult charts for information on locations of reefs, rocks, shoals, or other hazards to make sure that the yacht is not at risk of grounding or collision with fixed or floating structures.
- Frequently check that your route ahead and around the yacht is unobstructed (no yachts or objects in the expected route or approaching your yacht).
- Frequently confirm the yacht's position as you cruise, using all available aids, such as charts, visual observations and bearings.
- Before night navigation, make sure that navigation lights and search lights are operational. Ensure that the correct navigation lights are turned on for operation at night. Do not keep the anchor riding light on while the yacht is navigating.

- Use navigation lights in all conditions of reduced visibility, such as fog and rain and at all times between sunset and sunrise.



WARNING

When navigating at night, visual sharpness is crucial for a safe passage. To avoid collisions, reduce speed at night to compensate for limitations of visibility. Avoid switching on inner lights that may affect the captain's night vision.

- Know the characteristics of the sea bottom prior to anchoring. Keep well clear of other anchored yachts.
- During anchoring, pay special attention to avoid the rotating parts of the winch and take precautions when handling the anchor chain as it comes off the winch. Caution is needed to avoid injury to hands and fingers. Pay attention to ensure that your feet and legs do not get caught in the anchor rod.
- While the yacht is navigating, all persons on board must be seated in the designated seating areas in order to prevent injury due to falls caused by yacht movements with rough sea and in active wake areas or in the event of sudden changes in yacht speed or during manoeuvring. No one must be in the aft area when the yacht is under way.



WARNING

For comfort and safety, reduce the speed in the presence of waves.

**WARNING**

Persons entering the engine compartment when the yacht is navigating should be aware of the hazards of the yacht's motion and their potential exposure to high ambient temperatures, hot equipment components and operating machinery within the engine compartment.

Prior to entering the engine compartment, set the yacht on the most comfortable heading for sea and wind conditions. Persons in the engine compartment should maintain communication with the Captain.

**CAUTION**

To avoid heavy injuries or even death caused by hazards in the engine compartment, avoid the contact with hot and/or moving parts, while you are working in this area, wear proper safety clothing and also safety goggles and safety gloves. Be very careful around hot or moving parts. Wear hearing protection if the engines are running.

**DANGER**

It is forbidden to carry out sudden manoeuvres at high speed. This can result in accidents to persons on board.

**DANGER**

It is forbidden to stand or sit in the bow area during navigation.

**DANGER**

It is absolutely forbidden to perform reverse run with one of the two engines stopped. This operation is allowed only in case of life danger for the persons on board and for the safety of the yacht itself, however when the engine is running it should not run higher than 1000 rpm.

Observing the following guidelines will improve comfort, minimize noise inside the yacht, avoid damage and assist in the proper operation of the yacht.

- Do not run the engines at idle longer than necessary.
- Avoid sudden accelerations and decelerations, which create stress on engine turbochargers.
- Run at idle for a few minutes before shutting down the engines, to allow a gradual cool-down.
- Once the yacht is at cruising speed, the engine instrumentation readings should remain steady. However, if, during normal operating conditions, the engine gauges show abnormal or contradicting values, investigate for possible systems and/or equipment problems or failures (stop the engines).
- Monitor the control panel gauges and system condition alerts frequently.
- Once in open waters and well clear of other yachts, increase the engine rpm gradually, until the desired speed is reached. Adjust the interceptor positions for the best performance.
- Adjust the speed to accommodate sea conditions.
- Check the engine exhausts. Very black smoke means in particular dirty filters or unburned fuel, due to improper calibration of injection pumps or injectors. Very white smoke may mean presence of water in the fuel. Bluish smoke may mean abnormal oil combustion.
- In case of abnormal vibration, reduce speed and run at slow rpm until the cause of the vibration is determined. If the vibration is severe, take the engines out of gear. It may be necessary to check the propeller condition.

- Perform a visual inspection of the bilges periodically.

For the supply of fuel to consider the distance that we intend to cover.

**WARNING**

While the yacht is cruising, all persons on board must be seated in the designated seating areas in order to prevent injury due to falls caused by sudden yacht movements in active wake areas or in the event of sudden changes in yacht speed or during manoeuvring. No one should be seated on the stern area or on the bow area when the yacht is cruising.

11.8 SUGGESTIONS FOR NAVIGATION UNDER SPECIAL CONDITIONS

11.8.1 Navigation with bad weather conditions

It is very important during navigation in harsh weather, to make sure that all pieces of furniture, hatches, and mobile parts, are duly fastened or stowed, to avoid damages and above all to avoid hurting persons on board.

The reliability of machinery assumes even greater importance in adverse weather conditions.

The following table shows the maximum speed allowed in function of the wave height, in order to safeguard the yacht structural integrity.

Speed (knots)	Wave height in metres
10	0,80
11	0,70
12	0,63
13	0,56
14	0,51
15	0,47
16	0,43
17	0,39
18	0,37
19	0,34
20	0,32
21	0,30
22	0,28
23	0,27
24	0,26
25	0,24
26	0,23

Speed (knots)	Wave height in metres
27	0,22
28	0,20
29	0,20
30	0,19
31	0,19
32	0,18
33	0,17
34	0,17
35	0,16
36	0,16
37	0,15
38	0,15
39	0,14
40	0,14



WARNING

RIVA declines all responsibility for the improper use of the yacht, in relation to the wave height conditions.



WARNING

Before undertaking navigation, it is necessary to be aware of the sea and weather conditions you will find along the transfer route and in the area you want to reach.

Beaufort Scale	Descriptive Term	Wind speed		Probable wave Height (metres)	
		m/sec	knots	average	max
0	Calm	0 - 0,2	fino a 1	-	-
1	Light air	0,3 - 1,5	1 - 3	0,1	0,1
2	Light breeze	1,6 - 3,3	4 - 6	0,2	0,3
3	Gentle breeze	3,4 - 5,4	7 - 10	0,6	1,0
4	Moderate wind	5,5 - 7,9	11 - 16	1,0	1,5
5	Gentle wind	8,0 - 10,7	17 - 21	2,0	2,5
6	Fresh wind	10,8 - 13,8	22 - 27	3,0	4,0
7	Strong wind	13,9 - 17,1	28 - 33	4,0	5,5
8	Gale	17,2 - 20,7	34 - 40	5,5	7,5
9	Strong gale	20,8 - 24,4	41 - 47	7,0	10,0
10	Storm	24,5 - 28,4	48 - 55	9,0	12,5
11	Violent storm	28,5 - 32,6	56 - 63	11,5	16,0
12	Hurricane	over 32,7	over 64	14,0	-

11.8.2 Navigation with one only engine

The yacht is driven by two powerful propulsion systems designed to operate together and at the same time.

In case of failure of one of the propulsion systems, you may navigate with only one engine.

In this case, we recommend that you:

- Shut OFF the failed propulsion engine;
- Set the position of the steering wheels in the opposite direction of the failed propulsion system; in case the steering wheels cannot contrast the asymmetric push of the operating system, lower the interceptor on the side of the failed system, or reduce the speed;
- Head to the nearest landing at a reduced speed;
- Keep the yacht at a speed that allows you the best manoeuvrability.

In case one engine stops due to a failure and the stern drive is in idle position, during navigation keep a constant eye on the oil temperature of the stern drive connected with the failed system.

Should the temperature increases excessively over 80°C (176°F), lock the propeller shaft by engaging the stern drive: in this way the resistance will be higher, because the stern drive is jammed, but oil will not overheat.



WARNING

The yacht has been designed to navigate driven by two engines; please remember that it is possible to navigate with one engine only in case of emergency and for a very short time.



DANGER

It is absolutely forbidden to perform reverse run with one of the two engines stopped. This operation is allowed only in case of life danger for the persons on board and for the safety of the yacht itself; however when the engine is running it should not run higher than 1000 rpm.

11.9 TOWING THE YACHT

In case the yacht needs to be drawn or towed, fasten the towing lines as shown in the figure, in order to distribute the load evenly and pull in the middle.

The towing rope length depends on the sea conditions, and must be adjusted in such a way to limit the pulling forces without damaging the deck fittings.



WARNING

During towing, keep a constant eye on the water temperature, the oil pressure of the propulsion engines and maintain a suitable speed for the type of operation.



DANGER

Do not approach and do not carry out any kind of intervention on transmission during the towing because propeller can turn.



**WARNING**

In case it is necessary to tow another yacht, do this under calm sea and calm wind conditions only, and tow yacht with a displacement not exceeding 50% of your yacht displacement; in case of emergency, if towing is not possible, give help by taking on board people of the other yacht, as many as permitted and possible, and reach the nearest harbour. Anyway, inform immediately the Port Authority.

**WARNING**

Towing navigation can be carried out continuously for 8 hours, provided that you constantly monitor the stern drive oil temperature, which must not exceed 80°C (176°F). If temperature exceeds 80°C (176°F), stop navigation and wait until the temperature lowers. When the engine is shut off, the throttle position is unimportant.

**CAUTION**

Always draw other yachts or let your yacht be towed at low speed. Never exceed the speed of the drawing yacht when you are being towed.

**CAUTION**

Fasten your yacht to a towing rope so that it can be released when loaded.

**CAUTION**

It is the Owner's/operators' responsibility to make sure that the mooring ropes, the towing ropes, the anchor chain, the anchor line and the anchor are suitable for the intended use of the yacht, i.e., the resistance of the ropes or chain must not exceed 80% of the resistance to breaking of the relevant strength point. The Owner should also determine which action is necessary when fastening a towing rope on board.

**CAUTION**

Do not stand near the ropes during drawing (or towing) operations, a rope that breaks can be extremely dangerous ("whip lash effect").

**DANGER**

When towing, the propeller is kept rotating by the water flow. We recommend not carrying out any kind of service on the propulsion devices.

11.10 YACHT STEERING RULES

Yacht in sight

We can consider three ways of encountering another yacht on the water:

- Meeting;
- Crossing;
- Overtaking.

Normally, the yacht with less manoeuvrability has the right-of-way.

Stay clear of the yacht and pass to its stern.

The yacht, that has the right-of-way, is called the “privileged yacht”.

This yacht can maintain speed and course.

The “burdened yacht” is the yacht, which must adjust her course and/or speed as required to keep clear of the privileged yacht.

Meeting

When meeting another yacht proceeding on a parallel course, both yachts shall adjust the speed accordingly and keep on course.

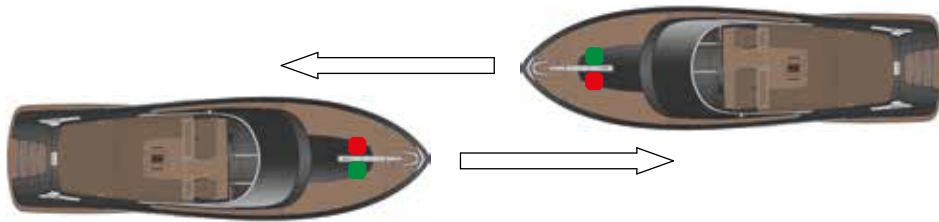

When two power-driven yachts are meeting on reciprocal or nearly reciprocal courses so as to involve risk of collision each shall alter its course to starboard so that each shall pass on the port side of the other.

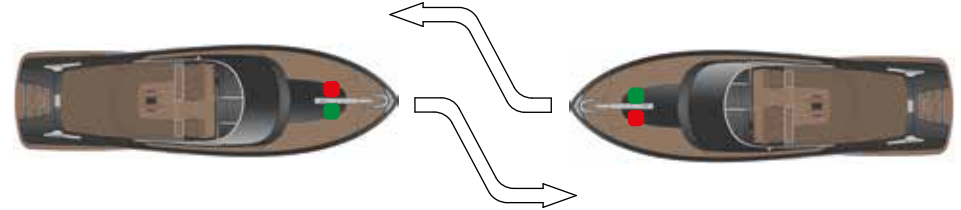

Crossing situation

When two power driven yachts are crossing so as to involve risk of collision, the yacht which has the other on its own starboard side shall keep out of the way and shall, if the circumstances of the case admit, avoid crossing ahead of the other yacht.

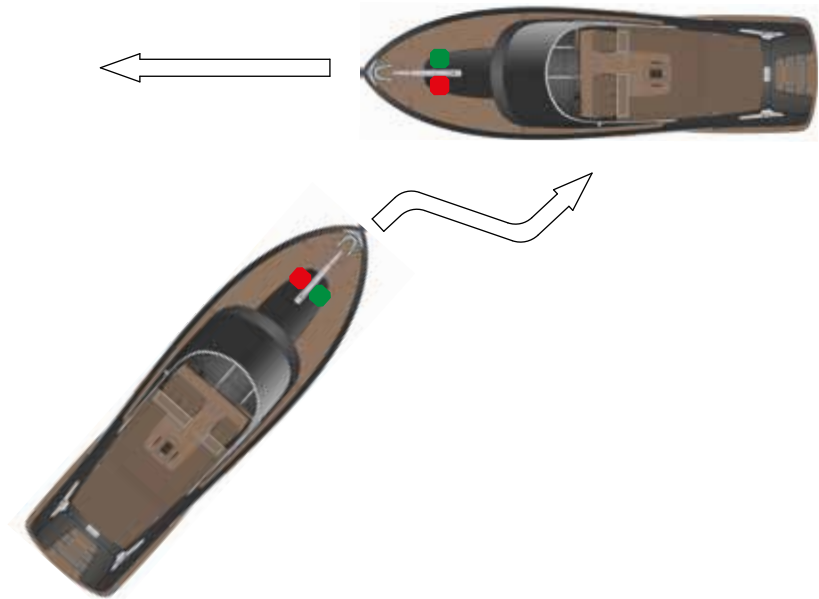

Overtaking situation

An overtake is defined as when one yacht comes from a direction of over 22.5 degrees aft, with respect to the yacht that it intends to overtake, in order that the stern lights can be seen but none of the side lights.

If you find yourselves overtaking a slower yacht, which is in your path, you are the burdened yacht. Make any adjustment necessary to avoid collision and pass either to port or starboard. Signal your intent to do so by sounding your horn twice if passing on the port and once if passing on the starboard.

The yacht being overtaken by another, takes precedence over the latter and thus must maintain the same route and the same speed no pull or manoeuvre.

The yacht that has the bow within a 135° angle (formed by the yacht stern light) is considered the yacht that can be reached.

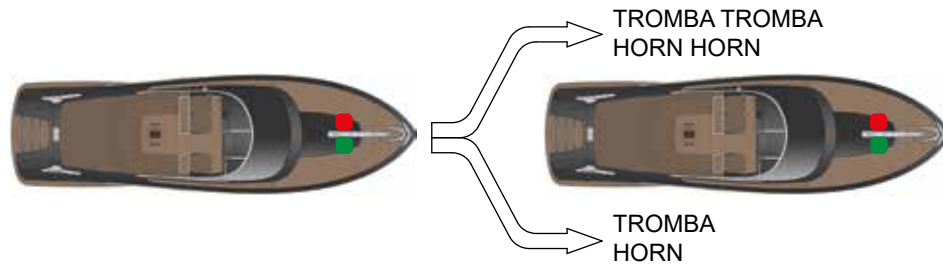

CAUTION

Having the right of course does not relieve you from the responsibility of avoiding a collision.

Responsibility between yachts

It is necessary to observe the following regulations, except when in conflict with other rules:

Mechanically propelled yachts, when underway, should keep the course clear for:

- Boats that are unable to steer.
- Boats with limited manoeuvrability.
- Boats engaged in fishing.
- Sailing boats.

Boats engaged in fishing, when underway, should keep the course as clear as possible for:

- Boats that are unable to steer.
- Boats with limited manoeuvrability.



CAUTION

Boats with limited manoeuvrability generally have the right of way. In the event of an impending collision, prudence shall take precedence over the right of way.

11.11 PREPARATION FOR ANCHORING



CAUTION

If the anchor has to be used, unlock it, check the wildcats clutch engagement and test the operation of the anchor winch from the helm position.

We remind you that the anchor winch system has no end stroke safety controls, therefore we suggest you to handle “manually” the last chain metres, by means of the apparatus positioned in the bow windlass locker, when this is near the hawsehole or when it is calculated to wind almost the entire chain.

To avoid overheating of the anchor winch, it is advisable to help recovering it, by moving slowly the yacht toward the chain, without approaching it too closely, so as not to damage the hull.

We recommend washing the chain after anchoring on muddy or algal seabed, during its recovery.



DANGER

Do not bring body parts or objects near the area where the chain or the lines are running. Make sure the electric engine is not supplied when acting manually on the anchor winch or when using the lever to release the clutch, as other people on board could operate the windlass from other helm position.

11.12 HAULAGE AND LAUNCH

Preliminary operations

Before proceeding with the operations for haulage or launch, check:

- No one is on board;
- There are no objects free to move;
- All doors and hatches are closed;
- All on-board equipment is disconnected and the possibility of activation is prevented.



DANGER

Haulage and launch operations should be carried out only by skilled personnel.

Always use the anchoring points to lift the yacht; if you must use the hull straps (not recommended), do not place them on stern drive. Use a spacer to keep the straps at an angle greater than the beam of the hull.



CAUTION

Bleed the mechanical seals each time the yacht is hauled / launched.



CAUTION

Always check the balance and stability of the yacht when lifting.



**CAUTION**

The lifting belts must be connected to the designated points; check that the belts are not folded or twisted.
Lifting hooks should be tight; lifting should be carried out gradually.

**DANGER**

Never stand near or below the yacht during hauling and launching operations.

Lifting the yacht

Before lifting, check the yacht's stability: the centre of gravity of the yacht depends on the loads and their position on board.

**CAUTION**

The lifting equipment used must be in good condition.
Lifting belts must not show wear.

When on the ground, the yacht must be positioned on supports of sufficient number and position to fully support its weight.

The inclination of the hull must be as "natural" as possible: this is to allow the on-board liquids to maintain a normal level and for rainwater to be properly discharged.

**CAUTION**

RIVA declines all liability for damage to property or persons if the operations are not carried out as described.

RIVA declines all liability for the position of the lifting bands, the support on the ground of the yacht and the positioning of the support points if carried out by third parties.

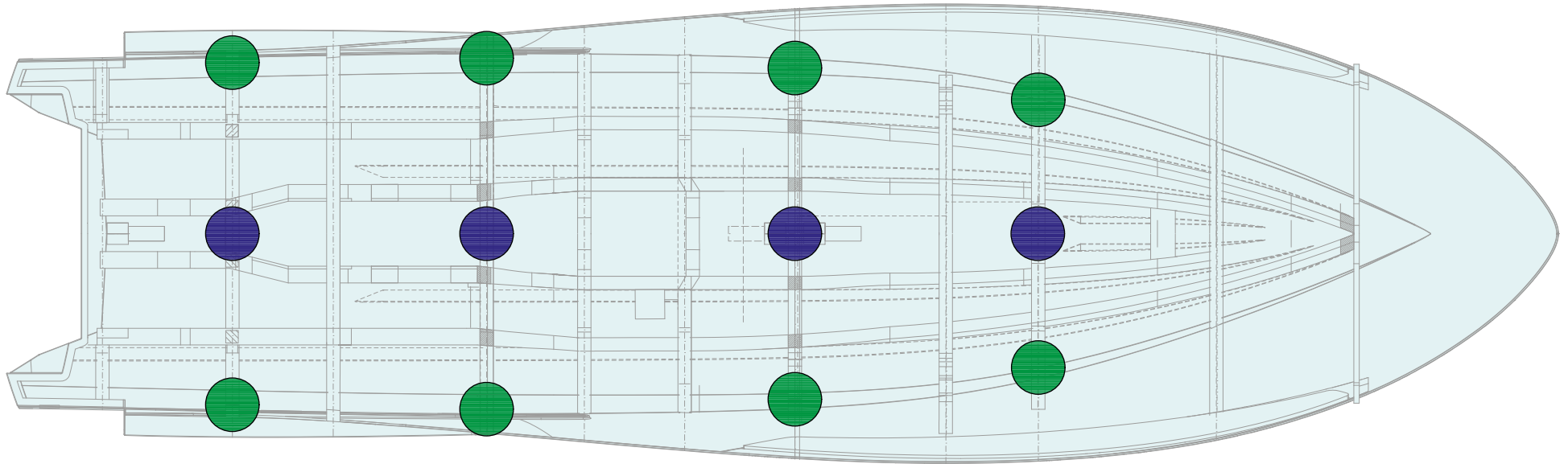



Riva

RIVAMARE CENTO

Riva

RIVAMARE CENTO

HULL AND FURNITURE MAINTENANCE

CHAPTER 12

12.1 GENERAL MAINTENANCE OUTLINES

The yacht is equipped with a large number of sophisticated devices and systems, which require not only a certain care when it comes to use, but also regular maintenance to obtain correct operation.

One of the factors that might cause problems or faults, is usually the irregular use of the yacht and because of this, of the on-board devices.

Daily checks and regular maintenance are important for maintaining equipment/components in the best working order and efficiency.

If the regular maintenance schedule is not correctly followed, the equipment's performance can deteriorate, causing reduced efficiency, a shorter life and the occurrence of unexpected problems which can compromise safety at sea.

The maintenance schedule is based on time intervals or running hours.

In case of a long period of inactivity (for example, during winter), it is advisable to lay up the yacht, possibly under cover.



CAUTION

Some general information about ordinary maintenance tasks, their schedule and procedures is provided herein with.

For further specific information referring to maintenance schedule, see Manufacturer Manuals of on board devices/components, issued by the various Manufacturers.



CAUTION

Look over the maintenance safety rules contained in this manual in order to act with the maximum safety and follow the indications here below.



CAUTION

During the replacements, remove the parts with care and order, in this way the assembly operations are as easy as possible.

Make sure to install genuine spare parts, in this way the system efficiency is not altered.

Sometimes the use of non-genuine spare parts may cause the withdrawal of the Manufacturer's warranty.

**CAUTION**

Check periodically that all equipment containing water is filled with the correct quantity of anti-freeze.

If the outside temperature drops below 0°C, all water systems are exposed to the risk of freezing and consequent breakage.

Systems especially subject to risks of freezing are all systems and devices containing either fresh or sea water.

**WARNING**

Before carrying out any maintenance and adjustment operation on the yacht, turn all necessary safety devices on and consider informing all personnel, in particular persons operating nearby. In particular, place warning signs in the areas concerned and prevent any device, if operated, from causing unexpected hazardous conditions, thus endangering the persons on board and/or property.

To avoid pollution, do not scatter any type of waste in the environment, and only use the dedicated disposal areas in the harbours.

**CAUTION**

When working in the engine compartment, switch magneto-thermal switches of the bilge draining pumps OFF, to prevent that fuel, lubricants and other liquid spilling causes sea pollution.

**CAUTION**

RIVA declines all responsibility for the installation and operation of electric, electronic or mechanical equipment improperly installed by third parties in a manner not authorised by the Shipyard.

RIVA declines all responsibility with regard to tampering carried out by third parties on equipment installed in the Shipyard. Such tampering or unauthorized installations will not only immediately void the warranty, it may also cause damage to the yacht and injuries to the people on board. RIVA declines all responsibility concerning regular maintenance operations scheduled by the Shipyard or by Manufacturers, but not carried out, on equipment/components, for which it is necessary to refer to the relevant Technical Manuals.

12.2 LONG PERIODS OF YACHT INACTIVITY

Following list only represents a general guide to give the customer an idea of the ordinary maintenances which should be carried out when the yacht remains stationary for a rather long period without being used.

We recommend carefully checking the instruction manuals of the single devices, because they often contain detailed information and very important specifications relevant to the maintenance of each device.

The following instructions NEVER REPLACE the specific instructions concerning each single device and issued by the device's Manufacturer.

- **Engines**
Before winter time let fresh water flow into the sea water circuit, check the antifreeze liquid, the sacrificial anodes against the galvanic currents, remove salt build-ups and spray protective agents.
Carry out the scheduled maintenance of the propulsion engines, indicated in the Use and Maintenance section.
- **Generator**
Use same procedure as for the engines.
- **Stern drive**
Carry out the scheduled maintenance for stern drive.
- **Batteries**
Check the liquid level and regularly charge the batteries, protect the terminals with Vaseline grease; the best solution would be to disconnect the batteries from the system and to charge them regularly with a separate battery charger, but this is not always possible on yachts.
- **Sun-deck cushions**
Remove all cushions and store them in a dry and ventilated place.
- **Aluminium and steel**
Wash all metallic parts with fresh water and protect by rubbing with a rag soaked into Vaseline oil.

- **Wood and interior upholstery**
Cover the cushions of sofas with sheets and above all cover all windows with the relevant covering sheets, so that as little light as possible is projected inside, because the UV-rays fade the wood and tissue colours.
- **Main deck**
Wash with water and neutral soap and treat with proper products. Sandpaper if strictly necessary.



CAUTION

DO NOT USE mechanical or forced water jet equipment (e.g. pressure washers, etc..) to wash the deck, as this force alters the wood and the caulking sealants (it detaches the microparticles) causing damage in some cases even radical (e.g. detachment of the staves).



CAUTION

DO NOT USE alkaline-based or acid-based detergents or aggressive detergents (soda, solvents, ammonia, etc..) to wash the deck; their aggressive degreasing action corrodes the wood (it eliminates its natural water repellency and whitens its natural colour), while the caulking sealant modifies its physical-chemical qualities, softening the surface, damaging the waterproofing, sealing and anchoring of the deck.

- **Sacrificial anodes**
Check wear and if necessary replace the sacrificial anodes.
- **LOG Transducer**
Pull out the propeller, clean it and apply the proper propeller plug.
- **Windscreen wiper**
Wash with fresh water and lubricate with Vaseline oil.

- **Anchor winch**
Protect the electrical components with a suitable protective spray and lubricate with silicon grease clutch and Barbotin.
- **Air conditioning**
Before winter:
 - Let fresh water flow in the sea water system.After winter:
 - Check the anti-freeze mixture in the fresh water circuit: top-up or replace it if necessary (perform replacement at least every two seasons).
 - Carry out the maintenance operations suggested by the Manufacturer.
- **Grey water tank**
Pour into the washbasin and shower drains sterilizing products.
Empty the tank and clean verifying the floating efficiency.
- **Black water tank**
Pour a sanitary product containing Paraformaldehyde into the WC and rinse the tank with this mix a couple of times. Drain the tank completely.
- **Bow thruster**
Protect the electrical components with a proper spray, check the oil level, and the sacrificial anode. If necessary, replace the anode.
- **Electro-hydraulic control units**
Protect with the proper sprays and check the oil level.
- **Fire extinguishers**
Check the loading condition and expiry date for regular inspections. Check also the correct positioning and preservation of every single extinguisher on board.
- **Safety equipment**
Check the correct positioning and the expiry dates of the self-inflatable means, flares etc..
- **Water tank**
Wash with disinfectant, drain the fresh water circuit, especially if frost is forecasted.
- **Fuel tank**
Cleaning by means of a decanter especially if there are traces of water in the fuel.
- **Engine compartment**
As for the engine compartment, we suggest carrying out a general cleaning, by removing all traces of salt drifts on devices and protect all electric, mechanic and hydraulic devices, by spraying them with protective agents.

General checks:

- Tidy the cabin, clean it and inspect all the on board wells.
- Check all hatches seals and lubricate their contact with appropriate silicone lubricant.
- Inspect the outer hull and all components: propeller, anodes, supports, interceptors, sea cocks, bow thruster.
- Carry out laying up of the yacht in a sheltered and dry place. If the yacht is stationed outside, cover it with a waterproof sheet, in such a way that allows ventilation. Otherwise the formation of damaging moisture could be helped.
- Wash the yacht with fresh water.
- Check all systems and fastenings on the yacht: damages, wear, cracks are signs of unsuitable use. Repair the damaged equipment. If necessary, fit new ones.
- Check the efficiency of scupper holes and that they are not clogged so as to cause the leaking of the bilge system.
- Check the fastening of the partial or total covering of the yacht.
- Disconnect all unnecessary utilities.

**DANGER**

During recharge the batteries produce explosive gas. Do not approach to recharging area with naked flames or sparkles.

Avoid wrong connections; never connect a positive terminal (+) with a negative one (-).

12.3 RE-USE OF THE YACHT AFTER A LONG INACTIVITY

Engines:

- After the winter, check engines oil, stern drive and replace them if necessary. Check oil and fuel filters and replace them if necessary.
- Adjust the tension of the alternator belts of the propulsion engines.
- Fill the fuel tank. Vent the air of the fuel system.
- Start propulsion engines.



CAUTION

After a long period of yacht inactivity, carry out all above-listed operations and following checks:

- Check the condition of all hoses and connections of the steering system, interceptors, swim ladder, etc..
 - Start the engines.
 - Stop the engines.
 - Clean fuel filters. Replace engine oil filters and add oil to the engines if necessary.
 - Check all bilge pumps and their operation.
 - Check the operation of the black water and sea water pumps.
 - Check the operation of all on-board instruments used for navigation.
- Let the engine run at middle speed for some minutes, before letting them run at full speed.

Generator:

- Start the engine of the generator.

Hull:

- Verify the hull.
- Have the bottom hull accurately cleaned, as well as the stern drive and interceptors with brushes (with water) or a jet-cleaner (dry) to remove seaweed and scales.
- Check the paintwork condition of the hull. If necessary, have 2 coats of suitable antifouling paint applied by specialized personnel.



Propellers and anodes:

- Check the status of the propellers and replace them if necessary.
- Check the conditions of the sacrificial anodes; if necessary, replace them.

Batteries:

- Check the batteries charge, and that their terminals and housings are dry and clean.

12.4 HULL MAINTENANCE

Problem	Cause	Corrective action
Bottom hull	Periodical cleaning and check of antifouling treatment (as required according to stationary area, but at least every three months)	<p>The length of the anti-fouling effects depends mainly on the conditions of the waters where the yacht is stationed.</p> <div style="border: 1px solid yellow; padding: 10px; text-align: center;">  <p>CAUTION</p> <p>When removing the old antifouling, do not use sandblasting methods, as this may damage the gel-coat surface and the anti-osmosis resin applied by the Manufacturer. As suggested by the antifouling manufacturers, use paint removers or, as an alternative, wet sanding.</p> </div>
	Check/restoration	The Shipyard uses high-quality ant-fouling paint and applies two layers.
	Preparation of the surface of an already treated yacht	<div style="border: 1px solid yellow; padding: 10px; text-align: center;">  <p>CAUTION</p> <p>Bad maintenance condition (barnacles, etc..) may cause cavitation and damage stern drive, propellers, etc..</p> </div> <div style="border: 1px solid yellow; padding: 10px; text-align: center; margin-top: 10px;">  <p>CAUTION</p> <p>Small areas of paint may peel off from the propellers even after a short period of operation.</p> </div>
	Washing of the yacht	Wash at each re-entering from navigation. Only use neutral and biodegradable products in case of dirt stains.
External coated parts	Cleaning	Do not use abrasive or cutting means. Wash at each re-entering from navigation.

Problem	Cause	Corrective action
Exposed metallic parts	Cleaning	<p>Wash with fresh water and dry with moistened (wash leather) cloth.</p> <p>When re-entering from navigation, wash with plenty of fresh water, especially the handrail base, the windows, the skylights, etc..</p> <div style="border: 2px solid yellow; padding: 10px; margin: 10px 0;"> <p style="text-align: center;"> CAUTION</p> <p>Also in presence of rusty spots, ALWAYS AVOID using brushes or abrasive rags on metal parts. Such a treatment would scratch the surface, damage the polishing of metal parts and reduce their mechanical features.</p> </div>

12.4.1 Bottom hull

Antifouling treatment

If scales build up on the hull, this causes notable speed reduction and with time may damage the “gel-coat”. When you choose an antifouling paint for your yacht, it is important that you find the proper product, suitable for your yacht and for the waters in which you are going to navigate. Contact the RIVA After Sales & Service Department.

Check/restoration

The cleaning and checks have to be carried with yacht at dry shore or with the help of a diver.

Have the repairs done only with yacht at dry shore.



WARNING

To clean or check the yacht in water, disable engines and generator ignition.



CAUTION

There are some hull areas (fastening area of stern drive, submerged drainage areas, around the thruster tunnel, etc..) where operations can be carried out after hull pressing; in these areas, fillers are usually used which, over time, may produce local faults, like bubbles or small cracklings. These little faults do not impair the hull’s mechanical strength at all. To repair them just sandpaper the area, remove the bubbles, and apply fillings suitable for the bottom hull.

- Have the bottom hull accurately cleaned, as well as the stern drive and interceptors with brushes (water) or a jet-cleaner (dry) to remove seaweed and scale.
- Check the paintwork situation of the bottom hull. If necessary, have 2 coats of suitable antifouling paint applied by specialised personnel.

Preparation of the surface of an already treated yacht

Carefully check the old anti-fouling paint to see if it is still good or if it needs a new layer. Make sure that the new product is compatible with the old one. Contact the RIVA After Sales & Service Department. If the old antifouling is crusty, thick and tends to scale off, then remove it and start the treatment as for a new yacht.



CAUTION

Antifouling is poisonous and should never be burnt, use only authorized disposal procedures and in case of doubts contact the authorities in charge. The sandblasting operations and removal of antifouling must be carried out with suitable clothes and protections.





WARNING

During the application of antifouling, make sure that following parts of the bottom hull are not painted:

- Depth sounder transducer;
- LOG speed sensor propeller;
- Sacrificial anodes;
- Stern drive.



Problem	Cause	Corrective action
Wood and upholstery	Regular cleaning	<p>The worst enemies of these materials are light and moisture; to protect them, they must be kept away from direct light as much as possible and the interior must be ventilated as soon as the weather conditions allow. The use of external awnings is extremely important because there is no species of wood, either natural or dyed, which, when exposed to the sun's rays, does not undergo a change in colour.</p> <p>The woods used for the yacht's fittings are exclusively natural-based materials carefully selected and the painting cycles with which they are treated comply with environmental regulations. Furniture made of wood, precisely because of the natural origin of both the material and the treatments, may be subject, if not properly treated and maintained, to:</p> <ul style="list-style-type: none"> • Colour variations due to exposure to direct and continuous light. It is advisable to shade the heavily exposed parts; • Retention of dirt if not cleaned promptly, given the characteristic absorbency of wood fibres. It is recommended to use non-aggressive products; • Scratches and marks if in contact with sharp or metallic objects, due to the inevitable relative "softness" of the wood. <p>Despite the painting cycles developed after many years of experience, wood remains a "living" material, and therefore subject to movement and settlement.</p> <p>Scratches caused by bumps must be repaired immediately, to avoid the blackening of the wood below. The technical staff of the RIVA After Sales & Service Department will advise you about the maintenance level you have to apply at the end of each season's use. Correct maintenance will allow you to avoid deterioration which is expensive to repair.</p> <div style="border: 2px solid yellow; padding: 10px; margin-top: 10px;"> <p style="text-align: center;"> CAUTION</p> <p>The extremely fine finish of glossy varnished woods is waterproof, but it is also delicate and requires proper maintenance. Such surfaces must therefore be dried after use or after rain and must be washed and maintained regularly.</p> </div>



Problem	Cause	Corrective action
Wood and upholstery	Regular cleaning	<div data-bbox="1420 288 1659 368" style="text-align: center;">  CAUTION </div> <p data-bbox="954 384 2123 520">Upholstery and wooden parts: the leather and wooden parts have to be treated as natural products, subject to colour alteration, particularly if the necessary precautions for good maintenance are not taken. RIVA therefore reserves the right to evaluate any problems and its own responsibility according to case.</p> <div data-bbox="1429 584 1648 616" style="text-align: center;"> MAINTENANCE </div> <p data-bbox="954 624 2123 687">At least once a week, carefully wash and clean all teak outside parts, and at least once a year perform a protective treatment with suitable products.</p> <div data-bbox="1420 759 1659 839" style="text-align: center;">  CAUTION </div> <p data-bbox="954 855 1122 887">Current use:</p> <ul data-bbox="954 895 2123 1031" style="list-style-type: none"> • Do not walk or jump on the cushions; • Prevent the cushions from turning yellow due to direct exposure to sunlight; • Prevent the absorption of water or moisture by not leaving the upholstery exposed to bad weather, particularly during periods of inactivity. <p data-bbox="954 1038 1077 1070">Cleaning:</p> <ul data-bbox="954 1078 2123 1174" style="list-style-type: none"> • Remove ordinary dirt with a warm water solution and neutral soap: do not use detergents or solvents; • Dry with a soft rag, not leaving any residues. <p data-bbox="954 1182 1133 1214">Preservation:</p> <ul data-bbox="954 1222 1962 1286" style="list-style-type: none"> • Store clean and dry upholstery in a cool, ventilated room with no moisture; • Do not place heavy objects on upholstery when stored.



Problem	Cause	Corrective action
Teak	Regular cleaning	<p>The characteristic of teak is its resistance to weathering and therefore, it does not require maintenance. Over time, teak tends to assume a particular silver colour that may not appeal; in this case, to maintain the original colour of the teak, it needs to be treated regularly with specific products (e.g. teak wonder).</p> <p>If the wood has smears that cannot be removed with normal washing, it is necessary to sand the wood to remove stains, and then repaint with wonder teak.</p> <p>You must use fresh water and manual brush (no hard bristles) at least once a day. This will remove any machinery, common dirt from feet and shoes, and normal environmental salt. This process, if carried out regularly, allows constant maintenance of your teak and caulking. In this case only time and wear will naturally deteriorate this product.</p> <div data-bbox="878 647 2074 839" style="border: 2px solid yellow; padding: 10px; text-align: center;">  <p>CAUTION</p> <p>Do not clean the teak with stiff brushes, as even rubbing the grain lengthways can damage the softer grain of the wood.</p> </div> <p>Non-black caulking may not behave in the same way as the black one. Any aesthetic issues, such as surface mildew, colour variations, dirt in the caulking are not defects and may be prevented with regular maintenance and service on the teak surface and caulking.</p>
Leather cushions	Regular cleaning	<div data-bbox="878 1038 2074 1161" style="border: 2px solid gray; padding: 10px; text-align: center;"> <p>NOTE</p> <p>For correct cleaning and care of the leather cushions, refer to the use and maintenance document provided in the annex to this manual.</p> </div>

Problem	Cause	Corrective action
Ceilings Panels	Regularly check the flatness of the panels and / or any discontinuities or steps between the ceiling panels	<p>Whenever the ceilings are disassembled, it is compulsory to check the status of the Fit Lock or/ and 3M Dual Lock fastening systems, breakage of the teeth, and/ or the entire system.</p> <div style="border: 2px solid orange; padding: 10px; margin: 10px 0;"> <p style="text-align: center;"> WARNING</p> <p>Do not install Fit Lock or 3M Dual Lock ceiling panels with damaged fastening systems, due to a possible reduction of their retention power. Damaged parts must absolutely be replaced with new ones.</p> </div> <p>In order to be sure that the ceilings have been reassembled correctly, check flatness with the other ceiling panels and the absence of discontinuities and steps between one ceiling panel and the others.</p>



Problem	Cause	Corrective action
<p>Light alloys and stainless steel</p>	<p>Regular cleaning</p>	<p>It is a good rule to accurately wash the entire yacht after each navigation, in particular all metal parts that may be damaged by sea water. Have plenty of fresh water sprayed on handrail, windows, skylights, rub rail, anchors, cleats and ladder. Protect all metal parts with Vaseline oil periodically.</p> <div data-bbox="880 435 2076 523" style="border: 1px solid black; padding: 5px; text-align: center;"> <p>MAINTENANCE At least once a year check the fastening of all metallic parts of the yacht.</p> </div> <div data-bbox="880 568 2076 754" style="border: 2px solid yellow; padding: 10px; text-align: center;">  <p>CAUTION Never use brushes or abrasive rags on metallic fittings, not even on rusty spots, scratches on the surface result in a less shiny appearance and diminish the mechanical features.</p> </div>

Problem	Cause	Corrective action
Outer furniture and cushions	General care and cleaning guide	<div data-bbox="882 264 2076 496" style="border: 1px solid yellow; padding: 10px;"> <p style="text-align: center;"> CAUTION</p> <p>Do not keep exposed to UV (solar light) for a long time without protections: when do not in use, take care to remove the cushions and stow them in a cover place or, if weather is good (not in raining days), you should cover the cushions to prevent deterioration.</p> </div> <div data-bbox="882 539 2076 978" style="border: 1px solid yellow; padding: 10px;"> <p style="text-align: center;"> CAUTION</p> <p>When not in use, remember to remove the sun-bathing cushions from their seats and to let them dry, so that no water or humidity remains between the cushions and the surface underneath.</p> <p>When washing the yacht or in case of rain, remove the cushions and stow them dry in a covered place.</p> <p>When possible, protect from direct exposure to the sun and/or to night humidity and/or weather.</p> <p>Make sure the external coating is not deteriorated and that the cushions do not absorb water.</p> </div>
	Cleaning and preserving	<p>Wash with fresh water at each re-entering from navigation, do not use hydro-cleaners, brushes or abrasive sponges.</p> <p>Let dry well in all its parts, especially the resting ones.</p>

Problem	Cause	Corrective action
Windscreen/windows	Regular cleaning	<div data-bbox="943 268 2130 491" style="border: 1px solid yellow; padding: 10px; margin-bottom: 10px;">  CAUTION Rags and chamois leathers used for cleaning glass must be replaced at least every 3 months. The inner side of windows and windscreen can be cleaned with non-aggressive and non-acid detergents for glass and a soft or paper cloth. </div> <div data-bbox="943 539 2130 762" style="border: 1px solid yellow; padding: 10px; margin-bottom: 10px;">  CAUTION If, after a normal cleaning, some traces of dirt or light scratches remain, do not try and remove them with mechanical means or using aggressive detergents, solvents or abrasive products. Contact RIVA After Sales & Service Department. </div> <div data-bbox="943 810 2130 1281" style="border: 1px solid yellow; padding: 10px;">  CAUTION For cleaning the outer side of windows and windscreen: <ul style="list-style-type: none"> • Evenly wet the whole surface of the glass with plenty of fresh water. • Use a neutral detergent or a delicate commercial product (not alkaline) diluted in fresh water. • Spread the solution with a soft and clean cloth. Frequently rinse the cloth in order to prevent deposits of dust or dirt particles which could scratch the glass or its glazed coating. • Rinse the soapy surface with plenty of fresh (or distilled) water. • We recommend drying the glass with chamois leather only. For cleaning the windows and windscreen it is possible to use the same type of detergent used for internal cleaning (non-aggressive and non-acid). </div>

Problem	Cause	Corrective action
Windscreen wiper and washer	Regular cleaning (as required)	Wash them carefully with fresh water and coat with Vaseline oil; grease the spring with silicone grease. Check the rubber blade conditions regularly, and replace the blades if worn; this prevents bad visibility problems.
Windscreen and deckhouse glass	Inspection of seals	<div style="border: 2px solid yellow; padding: 10px; text-align: center;">  <p>CAUTION</p> <p>At least once every 6 months check the condition of the glass seals. If you feel that the seals have deteriorated due to a wear, please contact RIVA After Sales & Service Department.</p> </div>
Light fittings	Regular cleaning	DO NOT use alcohol-based products to clean the light bodies.
Instrumentation and navigation lights	Regular cleaning (as required)	<p>Use clean wet rags for cleaning.</p> <div style="border: 2px solid black; padding: 10px; text-align: center;"> <p>MAINTENANCE</p> <p>At least once a week, check the operation of the navigation lights. At least once a week, carry out careful cleaning of glasses and headlights. At least once every six months, check the presence of corrosion in the connections of the navigation light cables. At least once every six months, tighten the cable connections of the navigation lights.</p> </div> <div style="border: 2px solid yellow; padding: 10px; text-align: center; margin-top: 10px;">  <p>CAUTION</p> <p>Do not use chemical or abrasive products.</p> </div> <p>After navigation, cover instrumentation and equipment.</p>

Problem	Cause	Corrective action
Metal parts and connectors	Regular cleaning (as required)	Grease connectors and metal parts of the devices installed and exposed to moist and salty environment to prevent oxidation; pay particular attention to the above-mentioned components of the stern drive, control units, etc..
Fenders	Regular cleaning (as required)	Always keep all the fenders and their sleeves clean by washing regularly with fresh water, in order to prevent the salt deposited on them from scratching the paint of the hull.
Auxiliary deck equipment	Cleaning and preserving	Wash with fresh water and neutral products after each cruise. Protect against oxidation by cleaning the surfaces with a vaseline oil-moistened cloth.
Main deck	Cleaning and preserving	Daily wash using soft brushes with neutral products and fresh water. In case of surface damage or scratching, consult the Shipyard before undertaking repair. Do not use solvents or corrosive products. Polish metallic parts as described above.

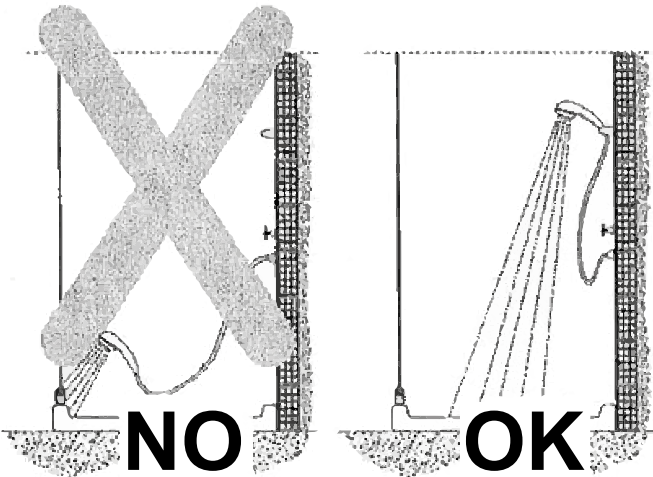
Problem	Cause	Corrective action
Shower	Checking and replacing gaskets	<div data-bbox="880 268 2076 459" style="border: 1px solid yellow; padding: 10px;">  <p>CAUTION</p> <p>Carry out periodic maintenance and/or replacement of the shower box seals, in order to prevent water leakage.</p> </div> <div data-bbox="880 499 2076 1369" style="border: 1px solid yellow; padding: 10px;">  <p>CAUTION</p> <p>The shower enclosures are made in such a way as to avoid water leaks outside the enclosure, under normal conditions of use of the shower. However, they do not have a watertight seal.</p> <div data-bbox="1153 758 1803 1236" style="text-align: center;">  </div> <p>The functionality of the shower cubicles is subject to the use for which it was designed; the water tightness is therefore conditioned by the correct use.</p> </div>

12.6 MAINTENANCE AND CARE OF VARNISHED WOODEN PARTS

Wood is a natural material, and for this reason, its aesthetic characteristics may change over time and depending on climate conditions (surface shrinkage, changes in colour and dimensions, etc.). The natural origin of this material means that each product possesses unique features that enhance its handcrafted character.

Caring for the wood on your boat is an act of love and respect for your vessel. From old panels that tell stories to new surfaces ready for future adventures, looking after the wood is key to maintaining the timeless elegance of our RIVA yachts.

Below are some essential tips that RIVA considers fundamental for the correct maintenance of your yachts.

To preserve the beauty of our yachts, whether dealing with aged wood or brand new surfaces, it's essential to adopt a dedicated care regime.

The maintenance of these parts includes cleaning, inspecting for hidden damage, sanding, and applying protective varnishes or oils. Regular check-ups are important to keep the wood in excellent condition and extend its lifespan.

Let's go through the key steps for caring for wooden surfaces:

- **Regular cleaning of surfaces.**

Regular cleaning is essential to maintain the wood's appearance. Use gentle detergents, preferably those specifically made for marine surfaces, to remove dirt, dust, and salt deposits that can damage the wood over time. Do not use pressure washers or high-pressure tools. Always wash with fresh water only, using a soft brush or scrubbing brush. Brush across the grain to avoid scoring the surface, then dry with a soft, dry cloth.

- **Inspection of the condition of the varnish and repair of damaged areas.**

Carefully inspect the wood for any signs of damage such as cracks, scratches, grooves, or mould. If the surface is still in good condition, a simple clean and possibly a light touch-up with a clear protective varnish will suffice.

If, on the other hand, the varnish is damaged or deteriorated, follow these steps:

1. **Sanding:** Use fine sandpaper to remove damaged areas and even out the surface;
2. **Cleaning:** After sanding, remove dust with a damp cloth or compressed air;
3. **Varnish application:** Varnishing is one of the most important steps in wood care. Apply even coats of high-quality marine varnish. Consider using polyurethane-based products for better durability and resistance to the elements, or choose exterior-grade varnish (e.g., water-based enamels or specific synthetic varnishes);
4. **Clear coat application:** After applying coloured or protective varnish (except on decks with maple inlays), apply a layer of clear coat. This layer serves to protect the underlying varnish from external elements such as moisture, UV rays, and temperature fluctuations, helping to prevent damage or fading. It also adds a glossy or satin finish to enhance the appearance.
5. **Drying and curing:** Allow each layer of varnish and clear coat to dry fully, according to the manufacturer's recommended times. Proper curing is crucial for achieving optimal hardness and long-lasting protection.

- **Inspection of the condition of silicone seals and repair of damaged areas.**

Deterioration of silicone (sealants) used on wooden parts of the boat can compromise the integrity of joints and cause water ingress, potentially damaging the wood. Here are some signs that indicate a deterioration of the silicone surface or sealed joints:

- Visible cracks or fissures;
- Warping or shrinkage;
- Colour no longer shiny and uniform but faded or opaque;
- Loss of elasticity;
- Accumulation of mould or algae;
- Water infiltration near sealed areas;
- Roughness or dustiness.

If one or more of these signs is present, remove the old silicone and replace it with a new layer of sealant. Ensure the surface is thoroughly cleaned before reapplying to guarantee good adhesion and prevent future leaks.

Timely replacement of silicone is important for maintaining the boat's integrity and protecting the wood from moisture damage.

- **Protection and precautions**

- Remove dirt, algae and salt with fresh water and a soft brush to prevent damage and deterioration;
- Regularly inspect wooden surfaces to identify and address any problems promptly, preventing more serious damage from occurring;
- Check that the silicone seals are uniform and that there are no cracks or degradation on the surface or in the joints;
- Avoid prolonged exposure to standing water;
- During the winter period or when the boat is not in use, use protective covers to reduce the exposure of the wood to the elements and temperature changes.

Summary table of operations:

Operation	Frequency	Description
Regular cleaning of the wood surface	At each use	Remove dirt, algae and salt with fresh water and a soft brush to prevent damage and deterioration.
Check for cracks or deformations	Quarterly	Regularly inspect the wood for cracks or deformations that could compromise the safety or durability of the wood.
Inspection of the varnish and finish	Quarterly	Check for damage or wear to the varnish and finish. Sand and reapply varnish as needed.
Checking the condition of the silicone seals	Every six months	Check that the silicone seals are uniform and that there are no cracks or degradation on the surface or in the joints.

Any restoration work on the boat must be carried out exclusively by authorised RIVA After Sales & Service Department using trained personnel.

Following the above recommendations is essential for maintaining the basic condition of the vessel and for upholding the boat's warranty.

12.7 SPEED MULTISENSOR (LOG) MAINTENANCE

Problem	Cause	Corrective action
LOG - speed multisensor with valve	Regular check - Ordinary Maintenance	<p>As indicated in the Manufacturer's manual.</p> <div style="border: 1px solid black; padding: 5px; margin-top: 10px;"> <p style="text-align: center;">MAINTENANCE</p> <p>At least once every six months check the correct operation. At least once every six months check the connection of the cables. At least once every six months check the propeller and grease the outer Log.</p> </div>

Riva

RIVAMARE CENTO

TROUBLESHOOTING

CHAPTER 13

13.1 GENERAL NOTES

The yacht is equipped with a large number of complex devices and installations.

These require regular checks and maintenance to keep their operation correct.

One of the factors that might lead to problems or faults, is usually the irregular use of the yacht and, as a consequence of this, of the on-board devices.

In order to analyse a malfunction it is appropriate to ask the following questions:

- Is the malfunction caused by a human error?
- Is the malfunction due to bad weather conditions?
- Is the malfunction due to a device failure or to a fault of another external device, but in some way connected to the first one?
- At what stage does the malfunction occur: at the start, at steady state, at device switch OFF?
- Does the malfunction occur repeatedly; if yes in which way?
- What does the malfunction imply from an operating point of view?
- Does the malfunction trigger any signals (luminous and/ or acoustic: sirens, buzzers, etc..) and/or messages on a display and/or anomalous noises (like whistles, beats, buzzes, etc..) and/or anomalous smells (burning smell)?
- Does the malfunction interfere with the operation of other devices?
- Is the malfunction a real apparent fault (that is, it can be cleared after a device reset and following switch ON)?

The best, most complete answer we can give to the previous questions, will give us a malfunction analysis.

This section of the Manual analyses the most likely causes, that may lead to the malfunctioning of a component of the main components/devices on board. For any possible analysed cause, a corrective action is advised, in order provide a solution to the problem that is as effective as possible.



WARNING

We recommend, in order to operate with peace of mind, in full safety, taking good note of the Safety Rules relevant to Maintenance described in the "SAFETY RULES".



WARNING

Corrective actions may only be carried out by specialised and authorised personnel.
RIVA declines all responsibility for proposed corrective actions carried out by unskilled personnel.



CAUTION

For more detailed information, please refer to the various Manufacturer's Service Departments or contact the RIVA After Sales & Service Department directly.

13.2 PROPULSION ENGINES

For further information, please contact RIVA After Sales & Service Department.

Problem	Cause	Corrective action
1. Engine does not turn when starter is actuated <ul style="list-style-type: none"> - Battery - Starter - Engine wiring - ECU Engine Control Unit - Engine - Start-interlock limit switch 	<ul style="list-style-type: none"> • Low or defective • Defective cable connections • Defective engine wiring or starter • Faulty • Loose plug-in connections • Gear locked (engine cannot start manually) • Limit switch not installed or defective • Defective wiring 	<ul style="list-style-type: none"> • Charge or replace (see Manufacturer's documentation) • Check that cable connections are properly secured (see Manufacturer's documentation) • Check that cable connections are properly secured, contact Service • Contact Service Department • Check plug-in connections • Contact Service Department • Check limit switch • Check wiring
2. Engine turns but does not fire <ul style="list-style-type: none"> - Starter - Engine wiring - Fuel system - ECU Engine Control Unit 	<ul style="list-style-type: none"> • Poor or defective starter rotation • Faulty • Not vented • Faulty 	<ul style="list-style-type: none"> • Charge or replace battery (see Manufacturer's documentation) • Contact Service Department • Check vent • Contact Service Department

Problem	Cause	Corrective action
<p>3. Engine fires unevenly</p> <ul style="list-style-type: none"> - Fuel injection equipment - Engine wiring - Fuel system - ECU Engine Control Unit 	<ul style="list-style-type: none"> • Defective injector • Faulty • Not vented • Faulty 	<ul style="list-style-type: none"> • Replace • Contact Service Department • Check vent • Contact Service Department
<p>4. Engine does not reach full-load speed</p> <ul style="list-style-type: none"> - Fuel supply - Air supply - Fuel injection equipment - Engine wiring - Yacht - Stern drive - Propeller 	<ul style="list-style-type: none"> • Shut OFF • Fuel pre-filter clogged (water/fuel separator) • Fuel filter clogged • Air cleaner clogged • Defective injector • Defective injection pump • Faulty • Yacht too heavy • Yacht's trim position • Marine growths on hull, propeller, stern drive • Stern drive position • After propeller replacement: propeller too small/large 	<ul style="list-style-type: none"> • Open shut-OFF valve before fuel pre-filter (water/fuel separator) • Replace • Replace • Check air cleaner clogging indicator • Replace • Replace • Contact Service Department • Check yacht's load condition, reduce load if necessary • Trim yacht • Trim yacht • Clean • Align stern drive • Replace only with original spares

Problem	Cause	Corrective action
5. Engine speed not steady - Fuel injection equipment - Speed sensor - Fuel system - ECU Engine Control Unit	<ul style="list-style-type: none"> • Defective injector • Defective injection pump • Faulty • Not vented • Faulty 	<ul style="list-style-type: none"> • Replace • Replace • Contact Service Department • Vent • Contact Service Department
6. Charge-air temperature too high - Coolant - Intercooler - Engine	<ul style="list-style-type: none"> • Incorrect coolant concentration • Contaminated • Air intake temperature too high 	<ul style="list-style-type: none"> • Check coolant properties • Contact Service Department • Check fans and ventilation air supply
7. Charge air pressure too low - Air supply - Intercooler - Turbo charger exhaust	<ul style="list-style-type: none"> • Air cleaner clogged • Contaminated • Faulty 	<ul style="list-style-type: none"> • Check air cleaner clogging indicator • Contact Service Department • Contact Service Department
8. Coolant leaks from intercooler - Intercooler	<ul style="list-style-type: none"> • Leaking, major coolant discharge 	<ul style="list-style-type: none"> • Contact Service Department
9. Exhaust gas black - Air supply - Fuel injection equipment - Yacht	<ul style="list-style-type: none"> • Air cleaner clogged • Defective injector • Defective injection pump • Overload 	<ul style="list-style-type: none"> • Check air cleaner clogging indicator • Replace • Replace • Contact Service Department

Problem	Cause	Corrective action
<p>10. Exhaust gas blue</p> <ul style="list-style-type: none"> - Engine oil - Exhaust turbocharger, piston rings, cylinder liner 	<ul style="list-style-type: none"> • Too much oil in engine • Oil separator clogged • Faulty 	<ul style="list-style-type: none"> • Drain engine oil • Replace • Contact Service Department
<p>11. White exhaust gas</p> <ul style="list-style-type: none"> - Engine - Fuel system - Intercooler 	<ul style="list-style-type: none"> • Not at operating temperature • Water in fuel • Leaking 	<ul style="list-style-type: none"> • Run engine to reach operating temperature • Check fuel pre-filter (water/fuel separator filter) and drain pre-filter • Contact Service Department

13.3 STERN DRIVE

For stern drive troubleshooting, please refer to the specific manual provided by the manufacturer.

13.4 BATTERY CHARGER

For further information, please contact RIVA After Sales & Service Department.

Problem	Cause	Corrective action
1. No output voltage from the charger	<ul style="list-style-type: none"> AC voltage not supplied 	<ul style="list-style-type: none"> Check installation Check fuse valve, replace if necessary
2. Battery charger does not operate	<ul style="list-style-type: none"> AC voltage not supplied Input voltage too low The battery charger will not operate below 160/80V 	<ul style="list-style-type: none"> Check installation The AC green LED should light up, if power is supplied Check fuses or circuit breakers Check the input voltage
3. The battery charger does not operate, while mains voltage is present	<ul style="list-style-type: none"> Mains frequency could be too high or too low The frequency must be within 35-66 Hz 	<ul style="list-style-type: none"> Check the input frequency Check
4. Batteries not fully charged	<ul style="list-style-type: none"> Charge current too low Current to load too high Charge time too short Battery temperature too low Defective battery (short circuit in cell) 	<ul style="list-style-type: none"> See "charge current too low" Decrease the battery load Replace the battery Use temperature sensor Replace the battery
5. Battery loses charge quickly	<ul style="list-style-type: none"> Battery capacity reduced because: <ul style="list-style-type: none"> - Wastage - Sulphating/stagnation 	<ul style="list-style-type: none"> Replace batteries Charge/discharge several times, this might help, otherwise replace batteries

Problem	Cause	Corrective action
6. Batteries are warm	<ul style="list-style-type: none">• Defective batteries (short circuit in cell)• Battery temperature too high• Charge voltage too high	<ul style="list-style-type: none">• Replace batteries• Use temperature sensor• Check the switches setting

13.5 USES

For further information, please contact RIVA After Sales & Service Department.

Problem	Cause	Corrective action
1. A connected utility will not receive power supply	<ul style="list-style-type: none">• Power line fuses blown• Wiring disconnected• Connections oxidised maintenance	<ul style="list-style-type: none">• Check the line and replace the fuses• Check wiring connections• Check and carry out proper maintenance

13.6 FUEL SYSTEM

For further information, please contact RIVA After Sales & Service Department.

Problem	Cause	Corrective action
1. Irregular fuel supply to engines	<ul style="list-style-type: none">• Circuit valves closed or not fully open• Filters clogged	<ul style="list-style-type: none">• Check/Open• Clean

13.7 WASTE WATER DRAINING SYSTEM

For further information, please contact RIVA After Sales & Service Department.

Problem	Cause	Corrective action
1. Improper drainage of the waste water tank	<ul style="list-style-type: none">• Circuit valves closed or not fully open• Lack of maintenance• Abnormal pump operation	<ul style="list-style-type: none">• Check/open• Carry out maintenance• Check

13.8 FRESH WATER SYSTEM

For further information, please contact RIVA After Sales & Service Department.

Problem	Cause	Corrective action
1. No water to outlets	<ul style="list-style-type: none"> • Circuit valves closed or not fully open • Tanks empty • Pump not receiving electric power supply • Protection pump mode 	<ul style="list-style-type: none"> • Check/open • Fill the tanks and bleed the circuit • Check • Reset
2. Pump starts even with outlets closed	<ul style="list-style-type: none"> • Circuit leaking 	<ul style="list-style-type: none"> • Leakage remove
3. The pump gets continuously on/off	<ul style="list-style-type: none"> • The tank has no air inside the membrane 	<ul style="list-style-type: none"> • Contact the Service Department

13.9 BILGE PUMPS

For further information, please contact RIVA After Sales & Service Department.

Problem	Cause	Corrective action
<p>1. Bilge pump does not run. No water pumped</p>	<ul style="list-style-type: none"> • Wire connections • Blown fuse 	<ul style="list-style-type: none"> • Check wire connection integrity, make sure wire connections are not corroded • A visual check may not be enough, a slight pull on each wire will indicate if wires are still connected • Check to ensure that no wire joints are hanging down into the water • Check the correct fuse size (fuse size is printed on the side of the bilge pump) • If fuse size is correct, check the impeller through the inlet opening to be sure it is not jammed or stuck with debris
<p>2. Repeated blown fuse</p>	<ul style="list-style-type: none"> • Fuse rating or clogged impeller 	<ul style="list-style-type: none"> • Re-check fuse to verify compliance to pump specifications • Also examine impeller area and clean any obstructions
<p>3. Pump runs without water output</p>	<ul style="list-style-type: none"> • Airlocking/cavitating • Pump strainer and impeller area clogged with debris 	<ul style="list-style-type: none"> • Inspect and reposition hose for short vertical discharge • We suggest installing pump below water line to ensure sufficient water flow • Faulty or clogged check valve may add to pump air locking • Disconnect pump and clean outside of strainer, clean debris around impeller, and reattached and re-hook wiring

Problem	Cause	Corrective action
4. Pump shaft corroded	<ul style="list-style-type: none"> Electrolysis, cracked housing 	<ul style="list-style-type: none"> Inspect pump housing for cracks which can cause leakage into engine cavity causing corrosion Possible incorrect current running through wiring causing corrosion.
5. Pump stays on after water is pumped out	<ul style="list-style-type: none"> Wire connections may be incorrect, automatic pumps may have faulty circuit, possible electrical short 	<ul style="list-style-type: none"> On bilge pumps check for correct positive and negative battery connections
6. Nozzle breakage	<ul style="list-style-type: none"> Hose clamp fastened too tightly 	<ul style="list-style-type: none"> Suggest using plastic style hose clamp, do not use PVC hose
7. Pump impeller spins backward	<ul style="list-style-type: none"> Check wiring 	<ul style="list-style-type: none"> Switch wiring for correct polarity
8. Wires overheated, melted insulation	<ul style="list-style-type: none"> Incorrect fuse size, possible jammed impeller 	<ul style="list-style-type: none"> Inspect & clean impeller area of any debris Make sure that impeller is free to rotate Check to make certain correct fuse rating is installed REPLACE ALL DAMAGED WIRING

13.10 GENERATOR

For further information, please contact RIVA After Sales & Service Department.

Problem	Cause	Corrective action
<p>1. Fluctuating or low oil pressure</p>	<ul style="list-style-type: none"> • Oil level too low • Dirty oil 	<ul style="list-style-type: none"> • Stop the generator immediately and top up with suitable oil • Replace dirty oil with new suitable oil
<p>2. Cooling water temperature too high</p>	<ul style="list-style-type: none"> • Excessive load • Air in the cooling circuit • Coolant low level or wrong mixture • Sea water intake is obstructed or sea water intake strainer is clogged 	<ul style="list-style-type: none"> • Reduce the load • Bleed the circuit • Restore the cooling water level and correct percentage • Clean sea cock and strainer
<p>3. Black smoke</p>	<ul style="list-style-type: none"> • Engine compartment insufficient ventilation • Excessive load • Unsuitable fuel • Cooling water temperature too high • Lack of maintenance 	<ul style="list-style-type: none"> • Check that air intakes are not obstructed • Reduce the load • Replace with suitable fuel • See step 2 • Have the scheduled maintenance operations carried out

Problem	Cause	Corrective action
<p>4. Blue smoke</p>	<ul style="list-style-type: none"> • Excessive oil • Dirty oil • Lack of maintenance 	<ul style="list-style-type: none"> • Discharge the excess oil by draining oil filters • Replace dirty oil with new suitable oil • Have the scheduled maintenance operations carried out
<p>5. White smoke</p>	<ul style="list-style-type: none"> • Cold generator • Generator with too low load 	<ul style="list-style-type: none"> • Let the generator warm up • Increase the generator load
<p>6. Lack of power</p>	<ul style="list-style-type: none"> • Engine compartment insufficient ventilation • Fuel filter clogged • Unsuitable fuel • Cooling water temperature too high • Lack of maintenance 	<ul style="list-style-type: none"> • Check that air intakes are not obstructed • Clean • Replace with suitable fuel • See step 2 • Have the scheduled maintenance operations carried out
<p>7. Excessive or unusual noise</p>	<ul style="list-style-type: none"> • Insulation cover not properly fastened • Leakage from the exhaust • Exhaust not properly fastened • Lack of maintenance 	<ul style="list-style-type: none"> • Check • Check the exhaust • Check the exhaust • Have the scheduled maintenance operations carried out

13.11 BOW THRUSTER

For further information, please contact RIVA After Sales & Service Department.

Problem	Cause	Corrective action
1. The electric motor does not turn and the warning light on the control panel is OFF	<ul style="list-style-type: none"> No electric power supply 	<ul style="list-style-type: none"> Check that the main magneto-thermal switch has been activated Check the status of the fuses of the control and main current; if necessary, replace them Possible presence of a short circuit; check the cables
2. The electric motor does not turn and the warning light on the control panel is ON	<ul style="list-style-type: none"> Presence of a foreign body in the tunnel, which blocks the thruster 	<ul style="list-style-type: none"> Check and eliminate the cause of the block
3. The motor turns too slowly	<ul style="list-style-type: none"> The battery is insufficiently charged Poor brush contact Presence of seaweeds or fishing line stuck in the thruster 	<ul style="list-style-type: none"> Adequately charge the batteries Replace the blades Proceed to clean
4. The motor turns (too) quickly but there is no propulsion	<ul style="list-style-type: none"> The safety pin has broken due to the presence of an object in the tunnel 	<ul style="list-style-type: none"> Replace the safety pin and eliminate the cause of the block of the thruster

13.12 GANGWAY SYSTEM

For further information, please contact RIVA After Sales & Service Department.

Problem	Cause	Corrective action
<p>1. The system does not react to the controls</p>	<ul style="list-style-type: none"> • Flat battery • Fuse 	<ul style="list-style-type: none"> • Verify that the battery of the sender is loaded or correctly inserted • Verify that the self learning of the sender code has been carried out • Check that the hydraulic control unit is correctly supplied; check for the integrity of the fuse
<p>2. The gangway does not move smoothly</p>	<ul style="list-style-type: none"> • The hydraulic power unit has a thermal protection 	<ul style="list-style-type: none"> • Wait until hydraulic power unit is disconnected (about 5 minutes) and retry handling on the adjusting trimmer (shift few degrees each time), if the problem continues, also with trimmer at bottom scale (clockwise) address to service department

Riva

A FERRETTIGROUP BRAND