

Riva

OWNER'S MANUAL

AQUARRIVA *special*

This manual has been drafted in compliance with standard UNI EN ISO 10240.
Any reprinting, either in whole or in part, without prior written approval by **FERRETTI S.p.A.** is strictly prohibited.
This manual has been issued by **FERRETTI S.p.A.**



A FERRETTIGROUP BRAND

Registered offices:

Via Irma Bandiera, 62
47841 Cattolica – Rimini – Italy
Tel. +39.0541.839611
Fax +39.0541.839625

Administrative headquarters:

Via Ansaldo, 7
47100 Forlì – Italy
Tel. +39.0543.474411
Fax +39.0543.782410
www.ferrettigroup.com

www.riva-yachts.com
customerservice@riva-yachts.com

1- FOREWORD

1.1 GENERAL INFORMATION 2
 1.1.1 Introduction to the use of the manual..... 2
 1.2 MANUAL INTRODUCTION..... 3
 1.2.1 Service request procedure - warranty..... 6
 1.3 KNOW YOUR RESPONSIBILITY AS OWNER..... 7
 1.4 NOTICES 8
 1.5 SPECIFIC SAFETY WARNINGS 9
 1.6 CERTIFICATION, CLASSIFICATION AND IDENTIFICATION 10
 1.6.1 Yacht identification specifications 11
 1.7 LOAD-CARRYING CAPACITY..... 12

2- SAFETY

2.1 SAFETY RULES AND WARNINGS 16
 2.1.1 Use-related rules..... 18
 2.1.2 Maintenance rules..... 20
 2.1.3 Fire prevention rules 25
 2.2 NOTES ON THE ENVIRONMENT 28
 2.2.1 Regulations for waste disposal 29
 2.3 SAFETY EQUIPMENT 30
 2.3.1 Arrangement of safety equipment..... 31
 2.3.2 Arrangement of fire prevention equipment..... 32
 2.3.3 Self-inflatable life raft 33
 2.3.4 Individual life jacket..... 36
 2.3.5 Life buoy 38
 2.3.6 First aid kit..... 39
 2.3.7 Signalling rockets..... 40
 2.3.8 Emergency boarding system 41
 2.3.9 Portable fire extinguishers 42
 2.4 MAN OVERBOARD RECOVERY 45
 2.5 ESCAPE ROUTES..... 46
 2.5.1 Abandonment of the yacht..... 48
 2.6 FORBIDDEN AREAS 49
 2.7 FIRE-FIGHTING SYSTEM..... 53

2.7.1 Engine compartment fire protection system..... 54
 2.7.2 Maintenance engine compartment fire protection system 57
 2.7.3 Essential restoring for resuming navigation 59
 2.8 ALARM DEVICES 60
 2.9 NAVIGATION LIGHTS AND DAYLIGHTS SIGNALS 61
 2.9.1 Navigation lights..... 61
 2.9.2 Daylights signals 64
 2.10 MANDATORY SAFETY EQUIPMENT 67
 2.11 LOCATION OF SAFETY PLATES..... 68
 2.12 SCHEDULE..... 69

3- DESCRIPTION OF THE YACHT

3.1 MAIN DIMENSIONS AND CHARACTERISTIC DATA..... 72
 3.2 GENERAL YACHT LAYOUT AND SECTORS..... 75
 3.3 MAIN DECK 76
 3.4 LOWER DECK..... 80
 3.5 ENGINE COMPARTMENT..... 81

4- HELM POSITION

4.1 HELM POSITION 84
 4.1.1 Upper section..... 87
 4.1.2 Port section 89
 4.1.3 Starboard section..... 90
 4.1.4 Port side section 92
 4.2 INSTRUMENTATION 94
 4.2.1 VHF-DSC Radiotelephone..... 94
 4.2.2 Engine control levers 96
 4.2.3 Steering wheel 96
 4.2.4 Chartplotter 97
 4.2.5 Thruster control panel..... 97

5- WATER SYSTEMS

5.1 FRESH WATER SYSTEM..... 100
 5.1.1 Cold fresh water system 103

5.1.2	Hot fresh water system	103
5.1.3	Maintenance fresh water system	104
5.2	BLACK AND GREY WATER SYSTEM	107
5.2.1	Maintenance of black water draining system	112
5.2.2	WC operation	115
5.3	SCUPPERS SYSTEM	116
5.4	BILGE SYSTEM	118
5.4.1	Maintenance of bilge automatic suction system	121
5.5	SEAWATER SYSTEMS	122
5.5.1	Maintenance of sea cocks and strainers.....	124
6-	ELECTRIC SYSTEM	
6.1	ELECTRIC SYSTEM	128
6.1.1	Maintenance of the electric system.....	132
6.2	ELECTRICAL PANELS	133
6.3	BATTERY SET	137
6.3.1	Checking and maintaining batteries.....	139
6.4	BATTERY BREAKER	141
6.5	BATTERY CHARGER	143
6.5.1	Battery charger maintenance.....	144
6.6	ELECTRIC SHORE POWER SUPPLY	146
6.7	FUSES	148
6.8	SACRIFICIAL ANODES	149
6.8.1	Checking and maintenance of sacrificial anodes.....	150
7-	PROPULSION SYSTEMS	
7.1	MAIN PROPULSION SYSTEM	152
7.1.1	Engine control panel	153
7.1.2	Start of propulsion engines	154
7.1.3	Checks after start of propulsion engines.....	156
7.1.4	Stop of propulsion engines	157
7.1.5	Emergency stop of propulsion engines.....	157
7.1.6	Engine maintenance	158
7.2	GEARBOX	161

7.2.1	Gearbox checks and maintenance	162
7.3	SHAFT LINE	164
7.3.1	Propeller shaft and through-hull seal	164
7.3.2	Mechanical shaft seal	165
7.3.3	Shaft line checks and maintenance	166
7.4	PROPELLERS	168
7.4.1	Propellers check and maintenance.....	168
7.5	ENGINES EXHAUST SYSTEM	171
7.5.1	Maintenance of the engine exhausts	172
7.6	FUEL SYSTEM	173
7.6.1	Fuel quality.....	176
7.6.2	Water/fuel separator filters for engines	177
7.6.3	Fuel system maintenance	179
7.7	BOW THRUSTER	180
8-	STEERING SYSTEMS	
8.1	STEERING SYSTEM	184
8.2	INTERCEPTOR	186
8.3	GYROSCOPIC STABILIZER (OPTIONAL)	188
9-	VENTILATION	
9.1	ENGINE COMPARTMENT VENTILATION SYSTEM	190
10-	AUXILIARY EQUIPMENT ON BOARD	
10.1	PREPARATION FOR MOORING	194
10.2	ANCHOR WINCH	196
10.2.1	Anchor winch maintenance.....	200
10.3	ENGINE HATCH SYSTEM	201
10.4	WINDSCREEN WIPER SYSTEM	201
10.4.1	Windscreen wiper system maintenance	202
10.5	BIMINI	203
10.6	COCKPIT TABLE (OPTIONAL)	205
10.7	SWIM LADDER	206

11- INFORMATION FOR USE

11.1	GENERAL INFORMATION	210
11.2	PRECAUTIONS FOR HARSH CLIMATES	211
11.2.1	Cooling system	211
11.2.2	Fuel system.....	212
11.3	PREPARING FOR NAVIGATION	213
11.3.1	Weather	214
11.4	FIRST PERIOD OF USE.....	215
11.4.1	Engine drive.....	216
11.4.2	Refuelling.....	217
11.5	WATER SUPPLY.....	219
11.6	UNMOORING AND MOORING	220
11.6.1	Leaving the mooring	221
11.6.2	Mooring manoeuvre.....	221
11.6.3	Mooring without people on board.....	222
11.7	OPERATION AND PRECAUTIONS AT SEA.....	223
11.8	SUGGESTIONS FOR NAVIGATION UNDER SPECIAL CONDITIONS.....	226
11.8.1	Navigation with bad weather conditions.....	226
11.8.2	Navigation with one only engine	228
11.9	TOWING THE YACHT.....	229
11.10	YACHT STEERING RULES.....	231
11.11	PREPARATION FOR ANCHORING.....	233
11.12	HAULING AND LAUNCHING.....	234

12- HULL AND FURNITURE MAINTENANCE

12.1	GENERAL MAINTENANCE OUTLINES	238
12.2	LONG PERIODS OF YACHT INACTIVITY	240
12.3	RE-USE OF THE YACHT AFTER A LONG INACTIVITY	242
12.4	HULL MAINTENANCE	243
12.4.1	Bottom hull	244
12.5	GENERAL MAINTENANCE	245
12.6	MAINTENANCE AND CARE OF VARNISHED WOODEN PARTS.....	254
12.7	SPEED MULTISENSOR (LOG) MAINTENANCE	257

13- TROUBLESHOOTING

13.1	GENERAL NOTES.....	260
13.2	PROPULSION ENGINES	261
13.3	GEAR BOX	265
13.4	BATTERY CHARGER.....	268
13.5	USES	270
13.6	FUEL SYSTEM	271
13.7	WASTE WATER DRAINING SYSTEM.....	272
13.8	HOT/COLD FRESH WATER SYSTEM.....	273
13.9	BILGE PUMPS.....	274
13.10	ELECTRO-HYDRAULIC STEERING SYSTEM.....	276
13.11	BOW THRUSTER	277



Riva

AQUARRIVA *special*

Riva

AQUARRIVA *special*

FOREWORD

CHAPTER 1

1.1 GENERAL INFORMATION

NAME OF THE YACHT _____ **AQUARIVA Special**
 TYPE OF YACHT _____ **MOTOR YACHT**
 PROJECT CATEGORY _____ **B**



CAUTION

Category B: A category B yacht is considered suitable to operate with winds of Beaufort force equal to or greater than 8 and significant wave height up to 4 metres. While such conditions typically occur on extended offshore voyages, they may also arise on coastal areas where shelter is not always readily available. These conditions may also be experienced on inland seas of sufficient size to generate a particular wave height. Depending on the weather conditions, winds can blow up to about 27 m/s.

1.1.1 Introduction to the use of the manual

Prior to operate the yacht and the equipment on board, read the manual carefully, in order to acquire an adequate familiarity with the systems and their operation, so as to avoid hazard to personnel and risks of costly damages.

A great passion for sea and the prestige of this yacht are elements that encourage constant and regular maintenance to ensure long periods of cruising, a long life span and an ensuing improvement in safety.

The maintenance operations described in the manual are simple, but should be performed by authorised and qualified technical staff only, according to standard procedures and in compliance with national and international regulations.

For specific interventions it is advisable to request the service of specialized technicians or contact our Service Department.

For an easy and quick consulting, the manual is subdivided in the following sections:

- FOREWORD
- SAFETY
- DESCRIPTION OF THE YACHT
- HELM POSITION
- WATER SYSTEMS
- ELECTRIC SYSTEM
- PROPULSION SYSTEMS
- STEERING SYSTEMS
- VENTILATION
- AUXILIARY EQUIPMENT ON BOARD
- INFORMATION FOR USE
- HULL AND FURNITURE MAINTENANCE
- TROUBLESHOOTING



CAUTION

Please keep this manual carefully in a safe, dry and easily accessible place for an easy consultation. When you decide to change the yacht, deliver this manual to the new owner in its integrity.

1.2 MANUAL INTRODUCTION

The documentation provided by RIVA to the Owner consists of two types of documents:

- The “**Owner’s Manual**”, edited by experienced professional staff in compliance with the regulations in force;
- The **Technical Document Collection**, concerning the on-board devices/systems (engines, air conditioning, etc..): it consists in a series of independent manuals, delivered by the relevant Manufacturer and/or Suppliers.

The Owner’s manual is the Main Document and must be read in whole, in any case before considering the documents in the Technical Document Collection.

The associated Technical Documentation Collection makes up the set of the Reference Documents that are required to complete the information provided in the Owner’s Manual.

Since these documents are independent and aimed at giving information on specific single components, it is necessary to refer to them when indicated by the Main Document.



CAUTION

RIVA recommends carefully reading the whole documentation delivered by the Manufacturers of the various components.

For all problems concerning the use and the maintenance of components you can refer directly to the Service Departments listed in the documents delivered by the Manufacturers.

Anyway, in case of need, some little interventions can be carried out by the staff on board, after consulting the operation manual.

This manual has been realized by RIVA in their mother language (Italian) and translated into other languages, to satisfy the customer’s requirements, and has been issued with the purpose of assisting you with the use of your yacht in full safety and with complete satisfaction.

This manual contains a detailed description of the yacht, of the systems and devices installed and practical information about its use and maintenance.

Always use trained and competent people for maintenance, repair and modifications. The changes that may affect the safety features of the yacht should be evaluated, carried out and documented by competent people. The manufacturer of the yacht can not be held responsible for changes that are not approved.

We recommend that you carefully read through this manual so as to become familiar with its contents before starting to cruise for the first time.

If this is your first yacht, or if this is a type of yacht that you are not familiar with, for your safety and to ensure your maximum satisfaction, make sure you have acquired sufficient experience about how to use and operate the yacht, before “taking the command”.



CAUTION

Make sure that the conditions of wind and sea correspond to the design category of your yacht and that you and your crew are capable of manoeuvring the yacht in such conditions.

Even when your yacht is classified accordingly, the conditions of sea and wind corresponding to design categories A, B and C ranging from storm conditions for category A to the conditions of wind and sea strong for the upper limit of category C, exposed to the dangers of a tidal wave or a wind gust.

These are therefore dangerous conditions, where only a competent crew, coached and trained on well-maintained yacht can operate satisfactorily.

THIS MANUAL MUST BE STORED AND WILL ALWAYS BE ON THIS YACHT AT EVERY TRANSFER OF PROPERTY.
SANCTIONS ARE ENVISAGED IF THE YACHT IS NOT EQUIPPED WITH THE "OWNER'S MANUAL".

IN CASE YOU LOSE OR DAMAGE THIS MANUAL, **RIVA** WILL ALWAYS BE ABLE TO SUPPLY YOU WITH A NEW COPY OF IT.



CAUTION

RIVA declines all responsibility for any damage to third parties due to discrepancies between the manual and reality.



CAUTION

This manual contains pictures of details not representing completely our yacht or with colours not corresponding to your arrangements. This is mainly due to the fact that it is possible to encounter problems during the realization of details' photos, like bed covers and sofas, which are defined only shortly before yacht delivery and therefore when the manual itself has already been issued.



CAUTION

In some countries, a license or permit to drive are required or specific regulations are in force.

This yacht may be conducted exclusively by authorized personnel to command and to the conduct of pleasure yacht in relation to the same class of the yacht.



CAUTION

All yachts, regardless of their strength, may undergo serious damage if used improperly.

This is not compatible with safe navigation.

Always adjust the speed and course of the yacht under the terms of sea.



CAUTION

If the yacht is equipped with a life raft, carefully read the operating manual. The yacht should have on board the appropriate safety equipment (life jackets, safety line, etc..) depending on the type of yacht, to the weather conditions, etc..

This equipment is mandatory in some countries.

The crew should be familiar with the use of all safety equipment and emergency manoeuvring (man overboard recovery, towing, etc..), cruising schools and clubs regularly organize training sessions.



CAUTION

All persons should wear a suitable buoyancy aid (life jacket / personal flotation equipment) when they are on the deck.

Note that, in some countries, it is a legal requirement to always wear a buoyancy aid that complies with the applicable regulations.

1.2.1 Service request procedure - warranty

The extensive RIVA service network is glad to provide you with any information regarding issues not addressed by the manual. Customers may contact Dealers, Sale Offices, Service Centres or directly:

RIVA AFTER SALES & SERVICE DEPARTMENT
 Via Ansaldo 7 - 47100
 Forlì - Italy
 Tel +39 0543 474445
 Fax +39 02 70058589
 customer.service@riva-yacht.com

RIVA has carefully selected all main components and accessories installed aboard your yacht, choosing among the most reliable manufacturers who, by offering a wide service network, also guarantee a speedy availability of spare parts.

 **CAUTION**

For all aspects related to the warranty of the yacht, please exclusively refer to what indicated in the sale agreement and in the warranty certificate in which all warranty conditions applicable to the purchased product are specified.

 **CAUTION**

The maintenance operations described in the manual are simple, but should be performed by authorised and qualified technical staff only, according to the standard procedures delivered by the devices Manufacturers and in compliance with national and international regulations. We suggest contacting the RIVA After Sales & Service Department.

 **CAUTION**

RIVA declines all responsibility for damage due to improper preservation and poor maintenance.

 **CAUTION**

RIVA declines all responsibility for the installation and operation of electric, electronic or mechanical equipment improperly installed by third parties in any unauthorised way by the Shipyard.

 **WARNING**

RIVA declines all responsibility concerning tampering carried out by third parties on equipment installed in the Shipyard. Such tampering or unauthorized installations will not only void the warranty, but may cause damage to the yacht and injuries to the people on board.

 **WARNING**

Equipment and devices: engine, winch, extractors and other devices are guaranteed by their manufacturers, who will service them directly through their service points. In case of need, the RIVA After Sales & Service Department will support your requests in order to provide you with a quick service and to guarantee the respect of the applicable rules. Upon yacht purchase, the Owner must send the Warranty Certificates of the relevant Manufacturers, in order to start the warranty period. RIVA will not be liable for undelivered Warranty Certificates.

1.3 KNOW YOUR RESPONSIBILITY AS OWNER

As owners of a yacht, it is your responsibility to be aware of several laws and rules applicable to navigation, operation and equipment of your yacht.

Personal flotation devices and other safety equipment must be approved by the Coast Guard and / or other organizations dealing with rules relating to safety. If approved, an adhesive will indicate on equipment itself.

Member States may impose additional requirements.

It is necessary that you know the rules that relate to your areas of action.

It is the responsibility of the owner and / or operator of the yacht to know the rules of navigation and safety and navigational practices.

Take up time to read the Nautical Rules of Navigation (COLREGS) that are found in the publication of the Coast Guard "Navigation Rules - International and Internal". CG-169 must be on all the length of more than 39 feet boats. Study the techniques of navigation and safety practices to run your yacht and its equipment.

You are the key person in ensuring the safety of your passengers, the crew and the yacht. Take up time to read the chapter on Safety in this manual for important information regarding the safety procedures.

Each yacht owner or operator must be well informed about the yacht and its systems.

Since you are responsible for the operation of your yacht, we provide you with information about these topics.

For every system on board we have planned a detailed description, including diagrams where appropriate, as well as information about the Maintenance and troubleshooting.

A variety of instruction manuals, courses and videos to help you to improve your knowledge of navigation rules, navigation, operation of the yacht, naval electronics operation, Maintenance, etc..

1.4 NOTICES

To highlight particularly significant sections and/or to indicate some important requirements, some symbols have been defined as follows.



CAUTION

It indicates a reminder to apply certain safety measures or to avoid certain unsafe practices that could lead to personal injury or damage to the yacht, to its components or to the environment.



WARNING

It indicates the existence of a possible hazard that may lead to personal injury or death, if proper safety precautions are not taken.



DANGER

It indicates the existence of a serious hazard that could involve a high probability of death or of serious injury if suitable safety precautions are not taken.



ENVIRONMENT

This symbol draws your attention to the possible hazards of environmental pollution.

NOTE

Draws your attention on information and important memos.

MAINTENANCE

This symbol indicates the maintenance schedules on the various on board devices.

1.5 SPECIFIC SAFETY WARNINGS

They integrate the general safety notice and are aimed at providing specific information about the nature of possible dangers.

Fire hazard:

To indicate a specific fire hazard.



DANGER
The cause of fire breaking is described here.

Electric shock hazard:

To indicate a specific electrocution risk.



DANGER
The cause of electrocution is described here.

Burn hazard:

To indicate a specific burn hazard.



DANGER
The cause of burn is described here.

Forbidden areas:

To forbid the access, the transit or the stay in a dangerous area.



DANGER
This area describes the forbidden area: for forbidden areas are meant dangerous places or the approaching to mechanical moving parts.

1.6 CERTIFICATION, CLASSIFICATION AND IDENTIFICATION

RIVA yachts undergo rigid and accurate tests required by the International Authorities in charge, in order to obtain a CLASSIFICATION CERTIFICATE.

The RIVA AQUARIVA Special yacht, on which you are about to cruise, has obtained the RINA S.p.A. (REGISTRO ITALIANO NAVALE) classification after supervision of the hull lamination, of the reinforcement structures, of the power system and of the safety equipment on board.



CAUTION

Always keep the plates readable and, if deteriorated or altered, address to RIVA for replacement.

NOTE

Builder's plate: Part of the information is provided on the manufacturer's plate affixed to the yacht.

The significant wave height is the average height of the waves that make up the highest third of the same, which is approximately wave height estimated by an experienced observer. Some waves know no twice this height.

In the figure aside you will find two plates shown in detail: Manufacturer plate and yacht identification code plate.

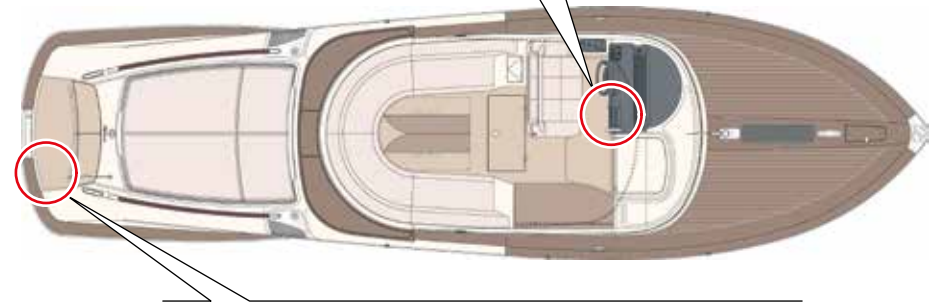
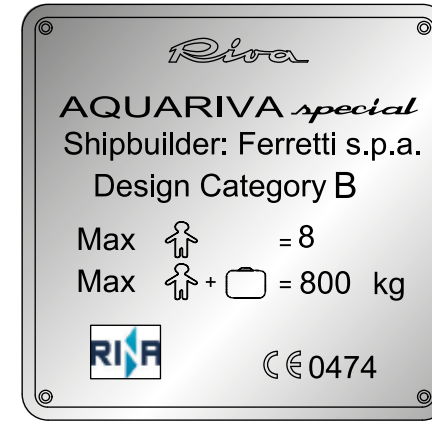

1.6.1 Yacht identification specifications

Manufacturer	FERRETTI S.p.A.
Model	AQUARIVA Special
Type of yacht	MOTOR YACHT
Identification number CIN (Craft Identification Number)	IT-FERRAVX0B626
Navigation class	B (navigation in the open sea: wind force can be equal to or less than 8 and the height of the waves up to 4 metres)
Certification forms	B+C+A1 (sound emission)
Classification	“CE” conformity in accordance with the standards set out by Directive 2013/53/EU

1.7 LOAD-CARRYING CAPACITY

Maximum number of passengers	no. 8 (RINA S.p.A. class.)
Maximum load recommended by the Manufacturer	800 kg (1.764 lb) (persons + luggage)
Safety equipment (standard)	no. 8
Berths	no. 2
Located in:	no. 2 in the cabin at the bow (double bed)



WARNING

Do not exceed the maximum recommended number of persons. Regardless of the number of person on board, the total weight of persons and equipment must never exceed the maximum recommended load. Always use the seats/seating spaces provided.



CAUTION

Make sure that safety equipment is perfectly efficient and available to each passenger.



CAUTION

The maximum load carrying-capacity includes the weight of all persons on board, all their luggage and personal effects and any other equipment not included in the unladen displacement.



CAUTION

When the yacht is being loaded, never exceed the maximum load carrying capacity.
Always take great care when loading the yacht and try to distribute the loads evenly so as to keep the correct trim.
Avoid placing heavy loads in the upper part to not reduce the stability.



CAUTION

The maximum load recommended by the manufacturer excludes the mass of the contents of the fixed fuel and water tanks when full. It must exceed the total load that can be added to the displacement to download and dry yacht.



CAUTION

The standard safety equipment furnished by the Shipyard is for the maximum amount of passengers.
Always check that the quantity of the above-mentioned safety equipment is at least equal to the number of boarded passengers.



CAUTION

Changes in the arrangement of the on-board masses, such as the addition of weights at the top, a structure, or the replacement of components with different specifications, can significantly affect the stability, trim, and performance of the yacht.

In such cases, contact RIVA After Sales & Service Department.

Riva

AQUARRIVA *special*

SAFETY

CHAPTER 2

2.1 SAFETY RULES AND WARNINGS

Your yacht has been designed paying the utmost attention to all aspects regarding your safety and the safety of your guests. However, all personnel on board must be instructed and aware about some precautions to be adopted at all times.

For this purpose, it is advisable that all people on board carefully read the guidelines contained in this manual, as well as the signs installed on the yacht and, in particular, all safety notices.

The time spent in reading such instructions will prevent unpleasant accidents; it is always too late to remember what was supposed to be done, after the fact. Remember that you are responsible for your safety and the safety of your passengers, and that you may jeopardize the safety of other boats.

Please make sure you are perfectly aware of the main safety rules:

- During normal operation or any activities on the yacht, keep passage-ways and escape routes in proper conditions, in order to avoid hazards to people's safety;
- Always perform regular inspections of hull conditions, power system, safety equipment, and systems on a regular basis;
- Always check the fuel level before cruising and compare the tanks' capacity with the engines' consumption and the length and the expected type of cruise;
- Check the expected weather conditions in your cruising area;
- In any case, always act according to common sense.

Safety is also "in the hands" of all those on board, who should be instructed and aware of some precautions to be adopted all times:

- Move carefully around the yacht because its stability may be suddenly affected by the sea waves;
- Persons on board must know the location of life jackets and the location of fire extinguishers (see safety equipment) and of the life raft;
- All passengers must be aware of the risks caused by the fires and the correct way to proceed in the event a fire should occur;
- Everybody on board must be able to release and launch the life buoy and the life raft at sea;
- The engine compartment must be properly ventilated when the engines are running or during cooling; the air vents must therefore always be open and free of obstruction.
- Access to the engine compartment must be allowed only to authorized personnel, aware of possible dangers like:
 - Moving mechanical parts;
 - Hot parts and components;
 - Circuits with pressurized, hot or irritating fluids;
 - Circuits with flammable fluids;
 - High noise when engines are running;
 - Possibility to shift important valves for navigation safety unintentionally.

Do not tamper with, disconnect, eliminate or by-pass the safety devices installed on your yacht. Periodically check their real efficiency in time to ensure that they can be used in case of need. Failure to meet such requirements may lead to serious risks to the health and safety of passengers.



CAUTION

Personnel performing any type of intervention must be properly qualified and follow the instructions of the equipment manufacturer. Failure to comply with these requirements may cause damage to your yacht and/or injury to people.



DANGER

When the yacht is being loaded, never exceed the maximum load carrying capacity. Always take great care when loading the yacht and try to distribute the loads evenly so as to keep the correct trim. Avoid placing heavy loads in the upper part to not reduce the stability.



CAUTION

Always place the necessary attention while navigating, especially in adverse weather conditions or breaking waves.

Take steps to ensure that objects or items which are not stored away or raised cannot: move during navigation; hinder transit; prevent the opening of internal doors; fall on persons on board; suffer damage; prevent the rapid location of necessary items in the event of an emergency.



DANGER

Carbon monoxide poisoning

Adequate ventilation of the yacht is required when the engines are running when navigating at low speeds or in conditions where fumes may re-enter the hull.



DANGER

The personnel in charge of the yacht must not be under the influence of alcohol, drugs or narcotics.



DANGER

It is absolutely forbidden to remain on the external decks outside protected areas during navigation.

2.1.1 Use-related rules

Your yacht has been realised with the utmost care by RIVA to grant the best possible reliability and safety to the persons on board.

It is anyway necessary to remember that these conditions, even if necessary, are nevertheless not sufficient, as reliability and safety are based upon strict and continuous observance, by the Owner and his/her Guests, of the so-called "On-board Ethics".

"On-board Ethics" means all those behaviour rules which all persons on board must strictly observe in order not to jeopardize the product that the Builder realised with so much care and professionalism.

Naturally, behaviour rules to be observed on board differ depending on the activity to be carried out.

Distribute loads so as to maintain the correct trim, do not overload the yacht, especially at bow and stern.

Observe the rules to prevent a sea collision and the speed limits, moreover pay always the highest attention during navigation.

The Captain, after having duly collected information on the yacht's operation and controls, should at first try and simulate some test manoeuvres with the aid of the Shipyard personnel, to familiarize with the controls and be aware of the typical reactions of this yacht.



DANGER

The responsibility for the operation of each boat lies solely with the captain.

It is the captain's direct responsibility to ensure, prior to departure, that the safety equipment required by law is present on board and fully functional.

The main operational steps, such as getting underway, navigation, anchoring and mooring must be carried out and verified scrupulously. In particular, all pre-departure procedures must be strictly followed.

All refuelling phases must be carried out taking all the precautions necessary to guarantee safety and to prevent even the smallest spillage of products which could pollute the surrounding environment.

When navigating near harbours, beaches and docks, observe the directives issued by local port authorities, particularly as to the speed; high speed can originate waves which can jeopardize the safety of the environment and of people.

Before lowering the anchor in free waters, check it it is allowed and verify the type of sea bottom, to prevent damaging or upsetting the surrounding marine habitat balance.

When entering and exiting, make sure that steps, handles and shoe soles are clean and dry.

In order to prevent the risk of injury, the instruments in the helm position must only be used from the correct piloting position.

**DANGER**

Do not use the yacht if the safety equipment is inoperative. Failure to meet this requirement may originate serious risks for the safety of your yacht and of your passengers.

**CAUTION**

Close portholes, windows and skylights while navigation, especially in poor weather conditions. Also, make sure that you have closed or locked doors to prevent collisions with objects or people.

**CAUTION**

Avoid sudden manoeuvres at high speed.

**CAUTION**

For greater safety and comfort, reduce speed in the presence of waves.

**CAUTION**

Any changes in the disposition of the masses on board, such as the addition of weights on top, a structure or the replacement of components with different specifications, can significantly affect the stability, trim and performance of the yacht. In these cases, contact RIVA After Sales & Service Department.

**DANGER**

Do not remove or alter the protections of moving parts, adopted by the manufacturers of the utilities on board and by the shipyard, when using the yacht.

2.1.2 Maintenance rules

In this section important information is given to enable you to operate the various components of the yacht without any hazard.

Periodical maintenance, including daily inspections, are important to keep the equipment/components in the best possible efficiency conditions.

Failure to comply with the maintenance plan may lead to unforeseen problems that can reduce safety at sea.

Read and understand all the information contained in the various technical manuals provided before undertaking any action or operating any systems. If you are not sure of aspect of the work to be done, please contact RIVA After Sales & Service Department that of the device manufacturer.



DANGER

Always operate with caution, care and under safety conditions.



ENVIRONMENT

Any maintenance operation must be carried out in the strict respect of the surrounding environment. Take all necessary measures to avoid that even one single “oil drop” may be spilled: the protection of our environment starts with this type of attention.

NOTE

Before carrying out maintenance and adjustment operations on your yacht, activate all safety devices provided and evaluate if it is necessary to inform all persons on board. In particular, according to the regulations in force, place warning signs in the areas that can be affected by the activity and prevent accessibility to any device or equipment that, if enabled, could cause hazardous conditions endangering persons on board and/or property. Maintenance and adjustment operations must be carried out by qualified, authorized personnel that shall provide for all necessary protections according to the regulations in force.

NOTE

Persons performing maintenance operations in barely accessible or dangerous areas must provide for their own safety and that of any other persons involved, in compliance with existing workplace safety regulations. If necessary, wear individual protection means required by the task to be performed.

During navigation, access to the engine compartment must be limited to authorized and properly equipped personnel only.

Inspect the sea water system inlets and outlets as well as the bilge systems. These checks are vital to ensure the yacht buoyancy.

Do not perform any maintenance operations or adjustments other than those indicated and/or suggested by the Manufacturer. If necessary, contact RIVA After Sales & Service Department for more precise instructions.

NOTE

Keep all parts of the yacht clean using the methods and specific products indicated by the manufacturer.

Use only oils and greases recommended by the manufacturer.

Use only original spare parts to replace worn parts.

Before maintenance or commissioning of the yacht or any component part, carefully read the instructions for use.

**DANGER**

The use of faulty lifting attachments can be the cause of accidents; check therefore their efficiency. Ensure the compliance of hoisting gears with local norms and their suitability for the job to be performed.

The use of unsuitable clothing can cause accidents; do not wear flapping clothes that could be easily caught by the moving parts of the yacht. Wear protective clothes suitable with the kind of work to carry out.

Keep OFF from taking alcohol or drugs before and during the work.

Insufficient information may cause accidents. If two or more persons are working simultaneously on the same machine, make sure that each of them is aware of the operation carried out by the others. Therefore, prepare a working plan so as to avoid any interference or hazard.

Before starting an engine, get other persons away from hazardous areas. Failure to comply with these precautions may cause serious injury, and even death.

When performing maintenance operations inside the engine compartment, you must make sure that the engine cannot be started from the helm position by unauthorized persons.

**DANGER**

Keep the entire work area, in particular the area around the engine and stairs, free of oil and grease stains.

Injury due to slipping may have serious consequences.

Oil leakage at operating pressure can cause injury: before disconnecting or connecting the hoses, stop the engine and operate the controls to release the residual pressure. Prevent the engine start when the hoses are disconnected.

When the outer temperature falls below 4°C inside the ducts where water flows, there is the risk that the water freezes inside them and, thus, that breaks occur.

Incorrectly mounted and/or damaged and/ or worn gaskets and O-rings can cause damage; replace them immediately.

**DANGER**

The battery produces explosive fumes; do not approach with flames and sparks nor smoke in its vicinity. If the battery is used or charged in a closed area, make sure good ventilation is provided. Do not check the battery charge status by short-circuiting the terminals with metal tools (the battery may explode): use a hydrometer or voltmeter. The electrolyte contained in the batteries is extremely corrosive: while charging or handling of the batteries, we recommend protecting your skin, eyes and clothing. Always use safety glasses and gloves. If the electrolyte gets into contact with the skin, rinse as soon as possible by washing with water and soap. If eyes are involved, immediately rinse with plenty of water and then ask for medical assistance.

Move away from the working area or adequately protect possible flammable materials, which could catch fire from sparkles.

Possible sparks produced by the electric system may cause explosions and fires. Avoid starting the yacht in the presence of flammable materials, liquids, vapours or flammable powders.

Fuel is flammable and explosive: do not approach with flames, do not smoke while refuelling or while working on the engine. Carry out refuelling with engine shut OFF. Failure to comply with these precautions may cause fires with hazard of serious damage to property and injury to persons.

**DANGER**

Suspended loads may fall and injure you. Do not walk or work under lifted devices not sufficiently and safely supported.
Due to moving mechanical parts, when working on the shafting and on engines parts, absolutely prevent starting of the latter.

**DANGER**

Before performing tasks on the electric system, always cut OFF power supply on the whole system or on the component on which you are operating, in order to prevent risks of shocks or electrocutions.
If necessary, first disconnect the negative cable from the battery and then connect it last to prevent short circuits.

**DANGER**

Precautions to safeguard your health:
Oil, fuel and antifreeze are toxic substances: do not swallow.
These substances also contain dangerous contaminating agents which may cause damage to the skin.
Protect your eyes from accidental splashes of toxic substances by using safety goggles.
Store products and technical fluids for yacht operation (such as anti-freeze) only in containers that cannot be mistaken for beverage holders.
Due to long and repeated contact with engine oil of any type, the skin can degrease and dry out with consequent irritation or even inflammation.

**DANGER**

Avoid long and repeated contact of the skin with toxic substances.
Protect the skin with suitable protective products or with safety gloves.
Clean the skin by washing it thoroughly with water and soap. A valid help can come from special hand detergents and a brush. Do not use any fuel, thinners or solvents to clean the skin.
After cleaning, treat the skin with special greasy cream.
Change oil-soaked clothes and shoes.

**DANGER**

If an accident occurs despite all precautions, seek medical advice immediately.

**DANGER**

Coolants are hot. When engine temperature is high, the cooling system is under pressure and, by removing the heat exchanger plug, the hot liquid can come out as a jet!

Wait for the system to cool down, then very slowly rotate the cap and vent the system pressure.

Always cover the cap with a cloth when performing this operation.

NOTE

RIVA declines all responsibility for the installation and operation of electric, electronic or mechanical equipment improperly installed by third parties in a fashion not authorised by the Shipyard.

RIVA declines all responsibility concerning tampering carried out by third parties on equipment installed in the Shipyard. Such tampering or unauthorized installations will not only immediately void the warranty, but may cause damage to the yacht and injuries to the people on board.

RIVA declines all responsibility concerning periodical maintenance activities scheduled by the Shipyard or by Manufacturers, but not carried out, on equipment/components, for which it is necessary to refer to their own Technical Manuals.

2.1.3 Fire prevention rules

Before operating the yacht, the captain must be familiar with the following fire prevention regulations.

The yacht must always be equipped with portable extinguishers, located as shown in the diagram "Arrangement of safety equipment".



DANGER

On all yachts, fire is a major danger.
All fire prevention measures must be followed scrupulously.

It is the direct responsibility of the captain of the yacht to do the following:

- Having fire-extinguishers and fire-fighting systems overhauled by the date shown on the label of each single extinguisher and have them replaced, as required by the rules in force, with other extinguishers of equivalent or even higher capacity;
- Informing the crew about the location and use of fire extinguishers and fire-fighting systems and escape routes;
- Ensuring that fire extinguishers are also available.

NOTE

The engine compartment of this yacht is equipped with a dedicated fire extinguishing system.



DANGER

Never:

- Obstruct passageways and the escape routes;
- Hinder access to safety devices, such as fuel valves, electrical switches, etc.;
- Obstruct access to fire extinguishers;
- Leave the yacht unattended, when burners or heat generating equipment are on;
- Use naked flames;
- Modify electric or fuel supply systems, without consulting RIVA beforehand;
- Smoke near or when handling flammable materials;
- Do not stow highly flammable materials near heat sources;
- Stow flammable material in the engine compartment. Non-flammable materials may be stowed only if properly rigged, so they do not accidentally come into contact with rotating engine parts, or obstruct access to the engine compartment.

Keep the bilges dirty and fail to inspect them frequently for possible oil or fuel leakage.

NOTE

Carefully read the prescriptions regarding the fire-extinguishing system and its use.

**DANGER**

In case fire breaks out in proximity to electrical equipment, do not use water, use the manual dry-powder fire extinguishers only. After using the extinguishers, leave and ventilate the area immediately before re-approaching it, in order to prevent asphyxia and physical harm. Clean out any fire extinguishing powder out very carefully.

In addition to these requirements, RIVA recommends the following:

- Avoid smoking lower deck, especially in the engine compartment.
- Avoid pouring liquids into the bilge and keep it clean, especially around the engine compartment. If there is fuel leakage from the engines, proceed as follows:
 - Stop all engines immediately;
 - Locate the leak cause and, if possible, repair it after closure of supply valves;
 - Dry and clean the bilge before restarting the engines, without draining at sea or in the harbour;
 - Do not stow flammable items in proximity to heat sources, like engines, halogen lamps, etc..;
 - Should the yacht leak, try to remedy with plugs and/or rags, if possible, from outside;
 - In case a system of the yacht breaks, close all hull valves, locate and repair the leak if possible. Remember to reopen all hull valves not involved.

NOTE

The Captain of a pleasure yacht must be perfectly aware of the basic fire fighting techniques and how to use the extinguishers.

**DANGER**

In case of fire on board, try to electrically insulate the area concerned by disconnecting all AC and DC input magneto-thermal switches to avoid feeding fires and short circuits.

**DANGER**

In case of the risk of the yacht sinking, close the fuel and black waters valves.

Regular and correct maintenance of the systems and prudent behaviour of all passengers are indispensable measures for preventing any risk of fire.

Nearly all fires, if detected early, can be extinguished easily.

For these reasons, it is necessary to carry out preventive surveys on a regular basis and identify all possible fire sources, and in particular:

- Check the proper operation of all main equipment/systems;
- Visit all compartments and in particular the engine compartment frequently;
- If a system does not work correctly, identify the failure and take the appropriate corrective actions;
- Operate all systems and equipment as specified.

If a fire is detected, identify and remove the cause, if possible, (e.g. in case of a short-circuit, cut-off the electrical system), extinguish the fire promptly and be vigilant to make sure that the fire does not break out again.



CAUTION

The ability to operate the fire extinguishers properly can ensure the success of the operation.
 It is vital that the fire fighting operations are performed by people competent in this type of emergencies.
 It is in any case necessary to be aware of the minimum fire-prevention and fire-fighting rules; the first defence is to prevent fires before they start spreading.



WARNING

EXPLOSION HAZARD

Any lithium battery powered device on board must be recharged only in open air areas, connected to a suitable charging system. Also please refer to the device dedicated Use and Maintenance Manual.

The following table contains the classification of the fire types:

Comparison between fire classes

American	Europe/Australia/Asia	Fuel/Heat source
Class A	Class A	Ordinary fuels
Class B	Class B	Flammable liquids
	Class C	Flammable gases
Class C	Class E	Electric appliances
Class D	Class D	Combustible metals
Class K	Class F	Cooking oil or fat

It is very important to use the correct extinguishing agent according to each fire class; normally, water can be used only for class A fires, together with chemical extinguishing agents (portable or fixed devices).

Each yacht owner/operator/master must be well informed and proficient regarding the measures to be adopted in the event of a fire and the applicable fire-extinguishing methods.

2.2 NOTES ON THE ENVIRONMENT

Environmental pollution is caused by three kinds of polluting agents:

- Water polluters;
- Air polluters;
- Soil polluters.

Non oily and black waters (containing only human organic waste) can be discharged into the open sea. In the port area, these must be collected in special tanks and then unloaded either by removal at open sea or by means of appropriate fixed shoreside or truck-mounted emptying systems.

Soil pollution is also caused by discharging waste at shore.

International regulations regarding recreational craft essentially provide for the following:

- During navigation it is forbidden to discharge any non biodegradable product, either of food or commercial origin, into the open sea.
- In ports, normal waste is considered to be similar to urban waste and therefore can be enclosed in plastic bags and disposed of in designated waste bins.
- Special waste must be disposed of into suitable containers or, if these are not available, it must be delivered to local waste disposing areas, in compliance with the norms in force, issued by the local Port Authority.



ENVIRONMENT

During navigation, do not dispose any on-board waste at sea, but keep it and dump it on waste containers ashore.

Remember that it is forbidden to dump oils and fuels into the sea; therefore, it is recommended to clean the engines' bilges by using absorbent materials to be disposed of later on into dedicated containers.

- The following waste is considered special waste:
 - Water and oily mixtures (e.g.: bilge water)

- Oils (fuel, additives and lubricants)
- Poisonous chemical substances (like battery acids, paints, thinners and the relevant containers)
- Spray cans containing C.F.C. gas
- Batteries
- Spent flares
- Expired pharmaceutical products
- Products containing lead or asbestos
- Etc..
- Fuel and oil leaks
- Waste discharge and disposal
- Excessive noise
- Wake / wake from board
- Exhaust fumes
- Paints, detergents and other agents

Please remember that, according to legislation, until such waste is delivered to suitable disposal areas, you will be considered as possessors and therefore indictable in case of unlawful discharge.

Should specific cases be missing in the harbour area, the Authority in charge for the disposal is the Port Authority section "Waste Disposal".



CAUTION

During navigation, it is always necessary to behave suitably and to respect the safety and the comfort of your guests and of persons on nearby yachts. Therefore:

- Avoid excessive noise;
- Do not leave the engines running for long periods without moving off;
- Do not cruise at high speed or beyond the permitted limits when leaving or entering harbours, marinas, etc., to prevent causing excessive wash or wave motion.

2.2.1 Regulations for waste disposal

The rules governing the discharge of waste (MARPOL 73/78) apply to all boats with no limits on tonnage and service, including recreational craft. The regulations apply to the entire Mediterranean Sea.

When moored in a harbour, always check that your yacht is not a source of pollution. The environment must be respected and safeguarded, preventing risks for the life of aquatic flora and fauna. It is good practice to leave no trace behind you, to respect laws on safety and environmental protection. Do not discharge bilge waste, oily residues, fuel or other liquids overboard. Solid waste and used engine oils should be deposited in the containers provided near the berths.



ENVIRONMENT

It is absolutely prohibited to throw plastics, synthetic cables, fishing nets, waste bags, floating packaging materials, paper, rags, metals, bottles, galley utensils and similar waste into the sea. Non comminuted or un-ground food waste can only be disposed of beyond 12 miles.



CAUTION

It is forbidden to discharge toilets or sealing tanks near the shore or in any prohibited area. Use the harbour or marina suction systems to empty the sealing tank before setting cruise.



ENVIRONMENT

Always consider and comply local and international laws against marine pollution (MARPOL). It is always necessary to respect the rules of good yacht conduct.



CAUTION

Within the 12 nautical miles off the coast it is forbidden to discharge the black water tank at sea: it is necessary to keep the exhaust pump OFF, excluding the activation automatism if present.

Although discharge at sea, except in special areas, of a wide range of ship-generated garbage is permitted at specified distances from the nearest land, preference should be given to disposal at shore reception facilities.

2.3 SAFETY EQUIPMENT

All persons on board must know the location and use of the safety equipment.



CAUTION

The diagram shows the position indicated by the manufacturer for safety equipment; therefore represents a useful guide the placement and number.

To adapt and place the safety equipment in accordance with local, national, and international laws.



CAUTION

Please note that the above mentioned safety systems must comply with local and international navigation laws.



CAUTION

The Captain is required to inform the crew on the yacht about the safety equipment, whether in case of fire or in case of sinking and listing.



CAUTION

Make sure that safety equipment is perfectly efficient and available to each passenger.





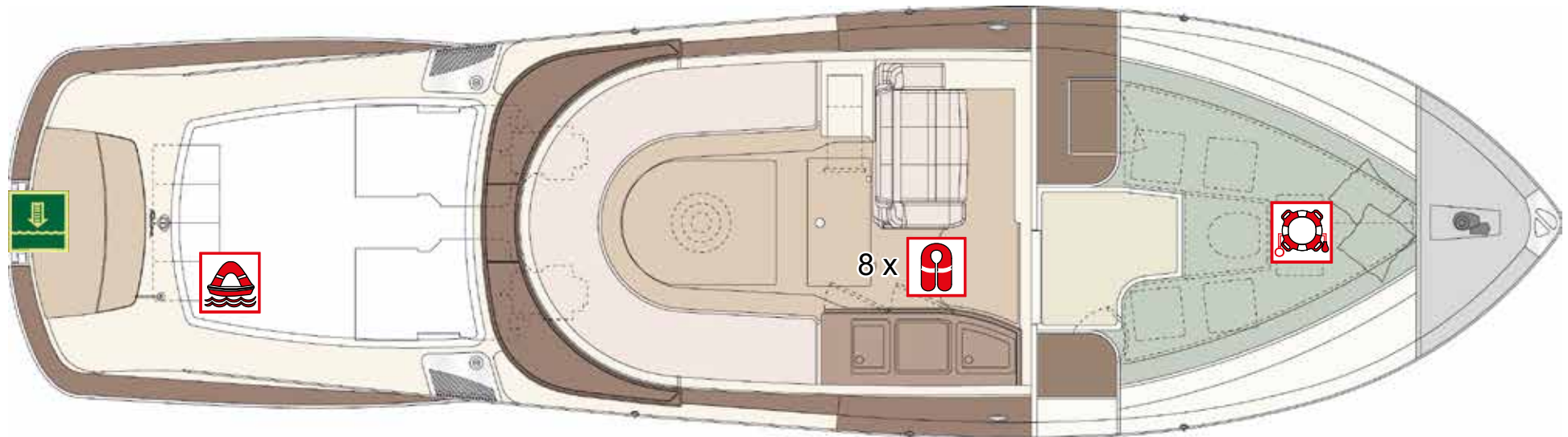

DANGER

Periodically inspect the wear conditions of safety equipment and check servicing or replacement dates, so that the equipment is always in perfect working order.

2.3.1 Arrangement of safety equipment



ICONA ICON	DESCRIZIONE DESCRIPTION
	Giubbotto salvagente per adulto con fischietto Life jackets light and whistle for adult
	Salvagente anulare con luce e cima galleggiante Life buoy with lifeline and light
	Zattera 8 posti Life raft 8 places
	Mezzo di risalita a bordo Emergency boarding system

2.3.2 Arrangement of fire prevention equipment

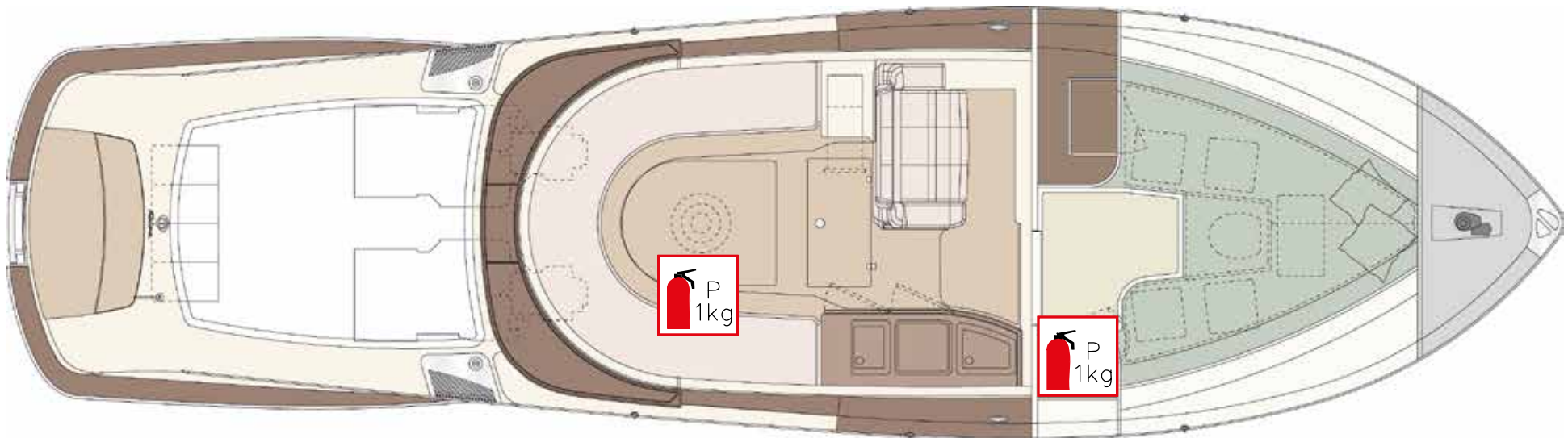

ICONA ICON	DESCRIZIONE DESCRIPTION
	<p>Estintore portatile a polvere 1Kg A-B-C RINA 5A/34B Portable powder fire extinguisher 1Kg A-B-C RINA 5A/34B</p>

2.3.3 Self-inflatable life raft

Self-inflatable life raft (1) must be used only in case of real emergencies, requiring the abandonment of the yacht.

The yacht must in fact be abandoned in case of a serious sinking hazard, or in case of fire becoming out of control.

In all other cases careful evaluation is necessary, because to leave the own yacht, even though on a self-inflatable life raft, could mean a more difficult identification the rescue team.

As a matter of fact, the search for the shipwrecked will start exactly from the last known position of the yacht.

NOTE

The validity of self-inflatable life raft is limited: check its expiry date on the certificate provided by the Manufacturer.

NOTE

Self-inflatable life raft can be overhauled at authorized Centres that shall extend the validity of the certificate. Sanctions are provided if this rule is not respected.



WARNING

Before any trip, check that there are no impediments to its immediate use.



In case the use of self-inflatable life raft becomes necessary, perform the following operations:

- Shut the engines down and put on the life jackets;
- Perform the distress call using the VHF device;
- Unwind the line for 3 or 4 metres; secure it firmly to a fixed point of the yacht and throw the self-inflating life raft into the sea from the leeward side;



WARNING

Check that the anchoring line is always well fastened to the yacht.

- Unwind the lifeline completely, then give a strong and decisive pull; the raft will open in a couple of minutes;
- Board by jumping directly from the yacht into the life raft;
- If you launch the distress call and receive an answer, prepare for a relatively short wait; assess whether or not to cut the restraint line. If you have not had the opportunity to make a distress call or have not been answered, prepare for a long wait; in this case, plan for survival, taking the following items, as well as the equipment included in the kit: floating smoke signals and rockets, a knife, drinking water and energy foods that do not cause thirst. Before boarding the raft wear all possible garments, except for shoes that could injure other shipwrecked persons or damage the life raft;
- If somebody falls overboard, help him/her to up into the life raft; throw the life buoy with line, if necessary;
- Make sure that everybody is on board, take the knife out of its sheath, and cut the line that ties the life raft to the yacht;
- Move quickly away from the sinking yacht, using the oars;
- When the overpressure valves have stopped hissing, close them by tightening the safety plugs.



DANGER

If the life raft opens upside down, jump into the water and roll it over, by pulling the special rope.

If the life raft does not open after the first pull, repeat the operation two or three times. If the life raft still does not open, jump into the water and, keeping a hand on the container, pull the emergency line strongly. If the life raft still does not open, cut the container open with a knife and operate the opening device directly (by pulling the life line).

The oars with which it is equipped are only suitable for minor manoeuvres.

- The life raft is fitted with stabilisers and a floating anchor, for improving its stability and drift. The stabilisers give stability to the raft. Keep the floating anchor into the water. The anchor prevents excessively rapid drifts.
- When the life raft is towed, weigh the floating anchor on board.
- With very high waves and strong wind there is the risk that the raft may overturn: shift the weight of persons on board towards the side tending to lift.
- If the life raft all does capsize, roll it over and return on board. If the sea is rough, it is advisable to wear the life jackets all the time. If the raft deflates, inflate it again from time to time using the relevant inflating device provided with the raft.
- If air blows out of a hole, use one of the plugs stowed inside the repair kit.
- You can perform minor repairs, by using the glue provided with the kit. Clean the torn area and the repair pad, spread both with the glue. Hold the pad for thirty seconds, pressing from the centre outwards, in order to eliminate any air bubbles.
- Hold down for a little time and inflate again, after one hour.



DANGER

All persons on board must know the position in which the self-inflating life raft is stored and the correct procedures for use.



DANGER

With very high waves and strong wind there is the risk that the raft may overturn: shift the weight of persons on board towards the side tending to lift.
If the life raft all does capsize, roll it over and return on board.

2.3.4 Individual life jacket

This kind of life jacket assures, by means of a suitable distribution of the floating material, the support of a body with the face out of water, apart from the position taken by the body when diving in the water.

These life jackets must be worn correctly and firmly tied by means of strong laces.

It is important to learn, particularly for children, how to float in water with the life jacket.

To avoid energy waste it is necessary to float by keeping legs and arms folded as far as possible and tight to the body to maintain the heat.

The individual life jacket is equipped with an orange whistle, fastened to the jacket by means of a safety cord.

The whistle is particularly useful to indicate the wearer's position when the weather conditions do not allow sufficient visibility (bad weather, fog, etc..).

The individual life jacket has to be worn under following circumstances:

- When you navigate through sandbanks or tide reefs;
- At first sign of bad weather;
- When visibility is limited;
- When you navigate with rough sea;
- When you navigate alone;
- At any time with children beyond 10 years of age.



CAUTION

The yacht must be equipped with a number of individual life jackets equal to the number of persons present on board. All persons boarded must know the location of the life jackets, how to wear them, how to tie them properly to the body, and where the whistle is located.



DANGER

If you are to choose a life jacket for a child, take care about for the correct size and that smaller children do not slip out of them once in water. We recommend that all children wear an individual life jacket when they move on the yacht.



CAUTION

CARING FOR AND INSPECTING THE LIFE JACKETS

The life jackets must be handled with care so that they are able to save your lives whenever necessary. Check that all the belts, braces and buckles are in good condition and firmly secured on a regular basis. Make sure that all the seams are steadfast and that any welded or glued part adheres perfectly. Check that the reflecting strip, whistle and light are firmly secured and that the light battery has not yet expired.

MAINTENANCE

Wash in warm soapy water after use.

Dry thoroughly.

Store in a dry, ventilated area away from direct sunlight and harmful chemicals.

Check the lifejacket regularly to make sure it is in good working condition.



CAUTION

Do not use the life jackets as pillows.

Practice of their use before you start navigating.

For people with problems may not be suitable.

With waterproof clothing or similar you can not reach the optimal use.

The use of lifejackets does not guarantee total safety and the final rescue of the wearer, but it does support in water for a long period.

2.3.5 Life buoy

The life buoy is equipped with a lifeline of 30 m and with an automatic light buoy.

The life line is not twistable and it is orange in order to be easily seen in water.

At least once a month:

- Check the fastening of the floating line;
- Check the loading condition of the batteries of light buoy;
- At least once every 6 months check the status of the floating line.



CAUTION

All crew and passengers must know the location of the life buoy.



CAUTION

The captain must ensure that the crew and passengers are familiar with the use of the life buoy:

- How and where to throw it;
- How to behave in case of “man overboard”.

2.3.6 First aid kit

The first aid box must be kept on board of class A crafts qualified for navigation“ with no limits from the coast”.

The container must be rigid, floating and with watertight closure.



ENVIRONMENT

It is forbidden to discard medicines at sea, even if expired. Treat medicines as special waste and therefore in accordance with the disposal procedures envisaged by the Country in which you are staying/ transiting.

This is the minimum quantity of medicines recommended for the Owner to keep on board:

- Disinfectant for external use;
- Ammonia;
- Bandages of various sizes;
- Plasters;
- Medicated plasters;
- Cotton wool;
- Scissors;
- Compressed hydrophilic gauze of various sizes;
- Compressed Vaseline gauze of various sizes;
- Tourniquet;
- Splints for fractures.



DANGER

Remember to check the expiry date and **availability** of the products contained in the first aid box at regular intervals.

Remember to store those medicines, which need to be kept in cool places in the fridge.

Inform all passengers of this.

Keep the first aid box in a place free from moisture and away from heat sources, easily accessible, quickly reachable in case of need and far from the reach of children.

2.3.7 Signalling rockets

Pleasure yacht are obligated to carry 4 manual rockets with red light and 4 manual orange smoke signals as required.

Always verify the legislation of the Country in whose waters the yacht is going to navigate.

- The signalling rockets have a limited lifetime; it is also necessary to check their expiry date and eventually to replace them.
- The floating smoke signals, visible up to 4 km, have to be used with the daylight, to indicate the correct position.
- The red light rockets, visible up to 10 km, are designed for night use, but they can also be seen during the day.
- Before using the signalling rockets, always wait for the arrival of an air plane or to see persons on the shore or on other crafts.
- Store the signalling rockets far from flammable liquids and from other fuels.
- As the content of the signalling rockets absorbs the moisture, make sure to have them located in a dry and accessible place.
- All persons boarded must know the place of the signalling rockets and the method of use.
- Carefully follow the activation instruction for all signalling rockets.
- Each month, and anyway before each navigation, check that they can be used immediately without obstacles.



DANGER

Keep the signalling rockets far from heat sources, such as flammable liquids or naked flames, and out of the reach of children.



DANGER

Once the signalling rocket has been lit, never direct it towards persons, there is a risk of burns and scalds.



WARNING

The signalling rockets have a limited lifetime, indicated on their containers. Once expired, contact the rockets suppliers which offer a disposal service. Do not light them unless necessary, because they can activate the Emergency Services.

2.3.8 Emergency boarding system

If you are in the water and in case of emergency or fall, you can use the safety "ladder" (1) and grip (2) located under the aft platform to get back on board the yacht safely and easily.

To do so, unlock the ladder and pull it up until you can place it into vertical position.



WARNING

After the use of the ladder for climbing on board, place it back to its correct position and lock it.
The boarding aid is a safety device and must be used only in case of emergency.



DANGER

It is the responsibility of the captain, when the yacht is manned but not under way, to ensure the possibility of returning on board by extracting the safety ladder.

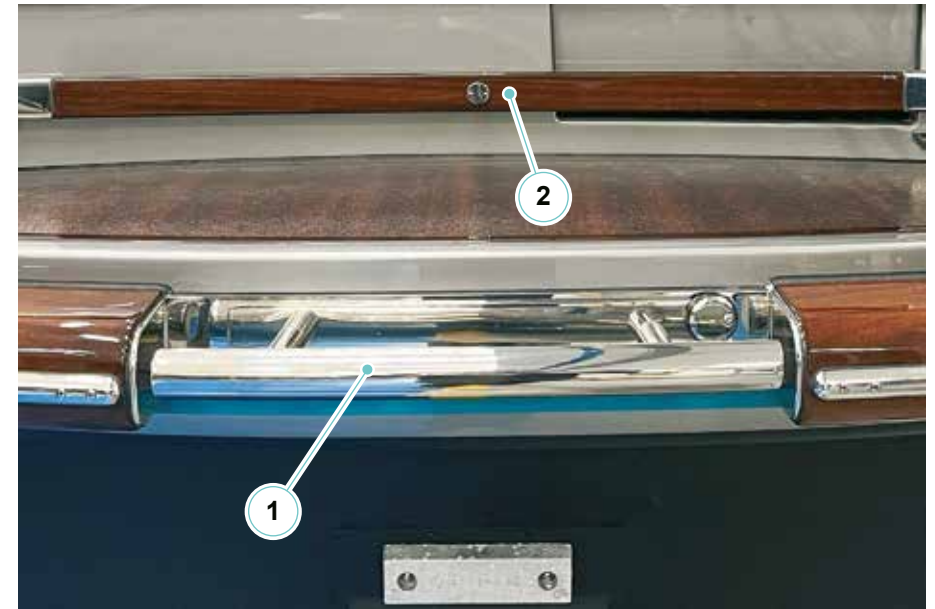

2.3.9 Portable fire extinguishers

Portable fire extinguishers are provided on board the yacht; these are designed to be transported and used by hand and comply with applicable regulations.

The fire extinguishers have been placed in visible and easily accessible positions, and the position is indicated by special plates applied by RIVA.

The use of a fire extinguisher requires a certain familiarity with it, but some theoretical-practical rules can facilitate its handling:

- Make sure that the safety pin against accidental discharge, has been removed;
- Always direct the extinguisher towards the bottom of the flame;
- Do not stand but try to bow as far as possible;
- Do not hit the fire from above;
- Shift the fan-shaped jet slowly from one side to the other of the flame;
- Act immediately before the temperature becomes too high;
- Always stay windward;
- If the material burnt is wood, paper or tissue, after the fire has been extinguished, pour on water to prevent any further spread of flames;
- Always act dressed, avoiding loose clothing or similar;
- Head the yacht so that the fire is leeward;
- Persons not engaged with the fire fighting must gather windward from the fire area and if necessary, disembark on a rescue device (tender, rubber dinghy, self-inflatable life raft), that must be linked to the yacht with a line, in order also to embark the persons engaged with the fire fighting;
- If the fire is big the operators must abundantly wet their clothing;
- The engines must be shut-OFF immediately and the fuel must be cut-OFF;
- Isolated objects in flames must immediately be thrown overboard;
- All openings that can allow air to penetrate through the flames must be closed;
- After using the extinguisher to fight fire in closed spaces, ventilate the space carefully, prior to entry, and remove powder deposits.



DANGER

The person in charge of the yacht must make sure that all passengers know the locations and how to operate the fire extinguishers on board correctly.



CAUTION

We advise regularly checking the charge status (visual check of pressure gauge and weight) and also its overhauling, according to the rules in force in the country whose flag the yacht flies.



DANGER

Pay particular attention during the cleaning and cooling operation because the components are still hot and can generate burns or scalds.

The arrangement of portable fire extinguishers is shown in the “Fire extinguisher location” diagram above.



CAUTION

All fire extinguishers should be checked at least every 12 months by qualified staff and in any case, after each navigation. Even after a partial use, the extinguishers should be recharged by authorized personnel.

Riva

The extinguisher should be kept in a good condition and the charge indicator, located on the pressure gauge, must always be positioned in the green field.

Keep the extinguishers in a vertical position.

After the use of a dry-chemical fire extinguisher, carefully clean the parts that came in contact with the powder because it is highly corrosive.



WARNING

For further information relevant to the use of the different systems and equipment, see the various manufacturers manuals, delivered separately.

AQUARIVA *special*

Portable fire-extinguishers maintenance

Component	Maintenance	Notes and precautions
Portable fire extinguishers	Checks and tests	<p>Check the state of charge of each fire extinguisher at least once every 12 months, and in any case before each journey at sea, by means of the installed pressure gauge. The fire extinguisher is correctly charged when the weight value is as stated on the fire extinguisher's tag, and the charge indicator on the pressure gauge is in the green area.</p> <p>If they are found to be discharged or insufficiently charged, or at least every 10 years, have qualified technicians:</p> <ul style="list-style-type: none"> • Check the condition of the container (cylinder); • Refill the extinguishing medium; • Carry out a hydrostatic test. <p>Have fire extinguishers recharged even after partial use.</p> <div style="border: 1px solid black; padding: 5px; margin-top: 10px;"> <p style="text-align: center;">MAINTENANCE</p> <p>At least every 12 months, and, in any case, before each journey to sea, check the state of charge of the fire extinguisher.</p> <p>At least every 10 years, and in any case before each journey to sea, check the external state of the fire extinguisher.</p> <p>At least every 6 months check the fastening of the fire extinguisher.</p> </div>

2.4 MAN OVERBOARD RECOVERY

Recover a man overboard before possible hypothermia or drowning.
Rescue is a combination of actions: reach the man overboard, establish a contact and bring him/her on board.

- Keep a visual contact with the man overboard.
- Slow down and go towards the man overboard. At night, direct the best light source available towards the man overboard.
- Launch the life buoy into the sea, towards the man overboard, and fasten it to the yacht by means of a line. It shall be used as a further reference to the rescuers.
- When approaching the man overboard, stop the yacht or slow down.
- When you are near the man overboard, stop the engines with the gear engaged, in order to avoid that the propellers continue rotating.
- Help the man overboard board the yacht.

NOTE

If the victim presents drowning symptoms, give specific assistance.
In case of serious danger, immediately make a distress call.

2.5 ESCAPE ROUTES

In order to cope with the different emergency situations that could require the abandonment of the yacht (fire, collision with sinking hazard, etc..) in the quickest and safest way, the rules in force require an “escape plan” informing about the safest as well as quickest paths for taking shelter and reaching the “muster stations”, located outdoors, from which it will be easier to leave the yacht.



CAUTION

Always keep the escape routes, dry, free and accessible.



CAUTION

The stairs must be carefully used during navigation.



DANGER

The on-board personnel must ensure that escape routes and paths are always free and accessible.

NOTE

All people on board must be aware of the risks and dangers that they can meet when aboard the yacht.
In particular, they must know which are the safest escape routes under different emergency conditions.



DANGER

According to the nature and position of the danger or fire source, to choose very carefully the safest and most suitable escape route.



DANGER

For safety reasons, the engine compartment access doors must be kept closed at all times and in all situations.
They must only remain open when in use.



ICONA ICON	DESCRIZIONE DESCRIPTION
	Via di fuga primaria Primary escape route
	Mezzo primario di fuga Primary mean of escape

2.5.1 Abandonment of the yacht

When you must abandon the yacht, swim against the current or windward.
The fuel leaks float in the direction of the current and can catch fire.
When you have taken shelter, count the person present on the yacht and help people in need.
Take advantage of the distress call.

Keep all people gathered in order to facilitate the rescue operation.

2.6 FORBIDDEN AREAS

On board the yacht some areas are “dangerous“, and need plenty of care, and possibly require wearing protective equipment, in order to safeguard the integrity of people on board.



DANGER

During navigation, the risks relating to any hazardous area increase significantly; we recommend scrupulously observing the safety rules indicated in this manual.

The areas are following:

- Engine compartment: area with a high level of noise, presence of moving components, hazard of burns, hazard of stumbling and falling. The access to the engine compartment is only allowed to trained and expert crew, prepared for the risks and equipped with proper safety devices, if necessary;
- Aft platform and bow area: outer area not protected by rails against falling into the sea. During navigation the access to this area is forbidden. Accessing and staying in this area is allowed only when the yacht is idle and with the engines shut OFF.

When underway, passengers can stay in the cockpit, preferably remaining seated. When moving, passengers shall use the special handrails installed in the cockpit.

In case of fall overboard, following rescue devices can be used:

- Life buoy;
- Individual life jacket;
- Emergency boarding system.

The following diagram marks out the dangerous areas, with different colours according to the risk level, where utmost care must be paid.



DANGER

Be careful when the deck is slippery.

NOTE



It is responsibility of the Captain to inform all persons on board about dangerous areas when they exist, possible areas temporarily forbidden when maintenance operations are being carried out, as well as about the correct behaviour to be adopted in the above-mentioned areas, also according to weather and sea conditions.

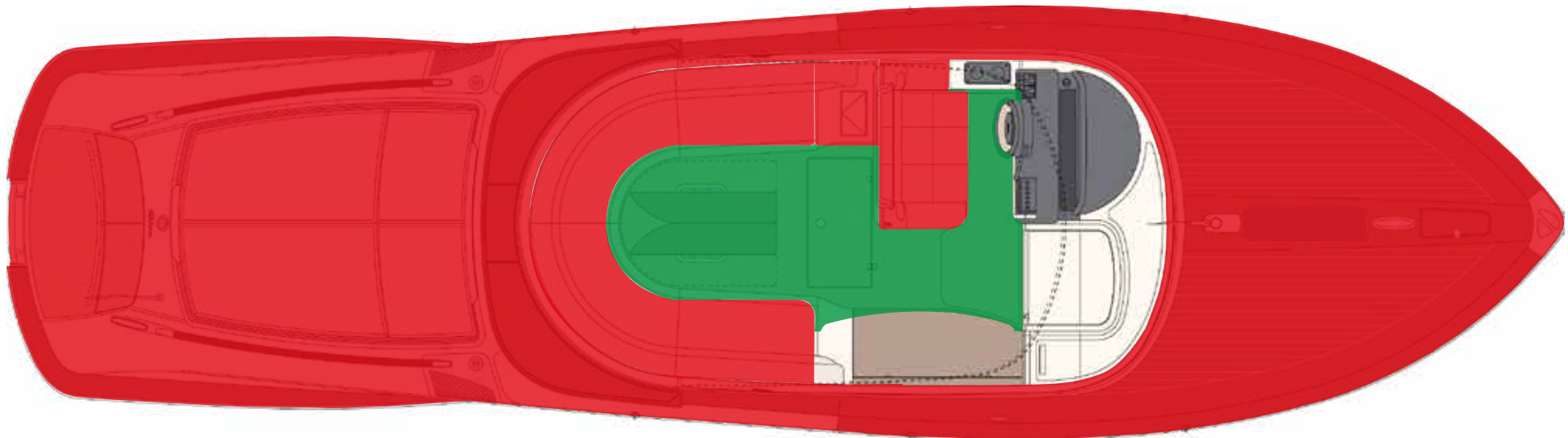

CAUTION

All the areas where there is polished fibreglass are no-step areas.



ICONA ICON	DESCRIZIONE DESCRIPTION
	<p>Ponte di lavoro: Area del ponte utilizzabile per il normale transito o sosta, quando le condizioni della navigazione e del mare lo permettono.</p> <p>Working deck: Deck area for normal transit or stopping when navigation and sea conditions so allow.</p>
	<p>Area interdetta: Area non utilizzabile in navigazione.</p> <p>Forbidden areas: Area not usable while at sea.</p>

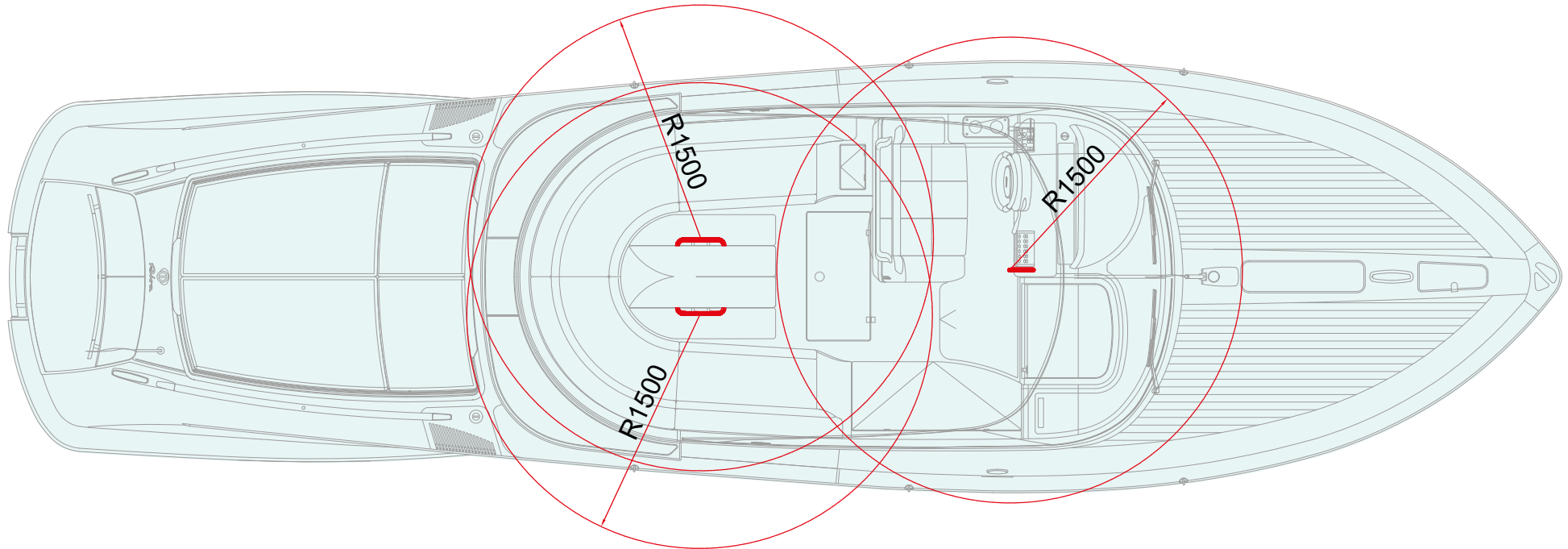

ICONA ICON	DESCRIZIONE DESCRIPTION
■	Maniglia Handle

Hooking points in the working deck area

Hooking points were provided on board the yacht in order to be able to move around safely.

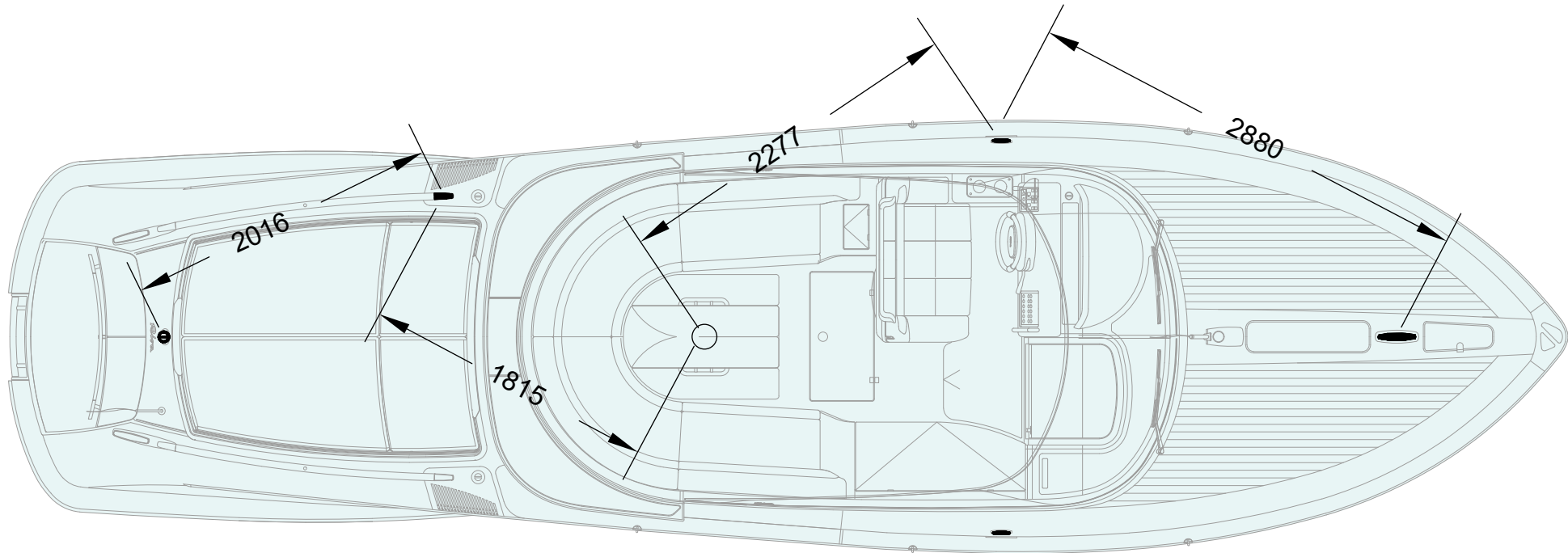

ICONA ICON	DESCRIZIONE DESCRIPTION
■	Punto di aggancio Hooking point

2.7 FIRE-FIGHTING SYSTEM

RIVA has made every effort, both as regards design and construction, to minimize the risk of on-board fires.

Once the fire has been extinguished, it is important to identify the cause that triggered it (if this has not already been done previously) and, if possible, to eliminate it, or at least to take proper corrective actions.

Fire-fighting protection of the yacht is made up as follows:

- Fixed NOVEC gas fire-fighting system (for protecting the engine compartment);
- Portable powder extinguishers;
- Safety plates.

NOTE

The equipment described above must only be used for its envisaged purpose.
No other use is allowed under current rules.



DANGER

Do not store flammable materials such as gas bottles, fuel containers, spray cans, etc.. in the engine compartment or near heat sources.
These objects must be stored in ventilated rooms and, if possible, on the outside.

2.7.1 Engine compartment fire protection system

The yacht is equipped with a fixed fire protection system to protect the engine compartment, which complies with regulatory requirements. The fire protection system consists of one NOVEC automatic gas extinguisher (1) located inside the engine compartment.

The NOVEC fire fighting system installed on board has been designed to complete the discharge in a few seconds from the activation. In this way it is possible to reduce the time in which the fire can develop and expand, thus causing damages.

Delivered, the NOVEC reaches all areas of the protected room (engine compartment), does not damage the most delicate equipment and does not leave residuals.

It allows avoiding also the costs inherent to cleaning and operation restoration, therefore it allows resuming immediately the activities on-board.

The discharge is automatically activated by means of a sprinkler, installed on the bottle and filled with liquid that, when the room's temperature increases, expands and breaks the sprinkler itself, causing system activation.

In the event that the discharge does not activate automatically, use the release (2) located near the helm position to manually activate the fire protection system after removing the safety pin.



DANGER

The extinguisher cylinders are provided with a safety pin. Make sure that such pin has effectively removed. Otherwise, in case of a fire, the extinguisher will be locked, preventing activation of the discharge, with subsequent serious damages to the yacht, and even her sinking.

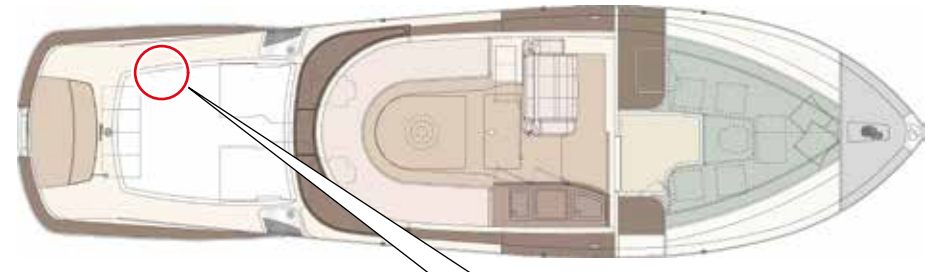

The NOVEC fire protection system is managed by an electronic control unit. In the event of a fire in the engine compartment, the extinguisher discharge is activated and the control unit stops the propulsion engines, the engine compartment extractors and the electrical system.



DANGER

The automatic fire fighting system that protects the engine compartment and the system room may not start under particular fire conditions and, therefore, it is **ALWAYS COMPULSORY TO MANUALLY OPERATE THE FIRE FIGHTING CONTROL TIE RODS.**



CAUTION

If a fire is detected, it is necessary to manually operate the system, without waiting for the automatic activation, in order to minimise the damage.

On the helm position, there is a warning light (3) indicating the charge status of the extinguisher located in the engine compartment.



CAUTION

The engine compartment is equipped with a fixed fire prevention system. To avoid asphyxiation, leave the area before system discharge. After discharge, ventilate the area before entering.

Engine compartment fire extinguishing system diagram

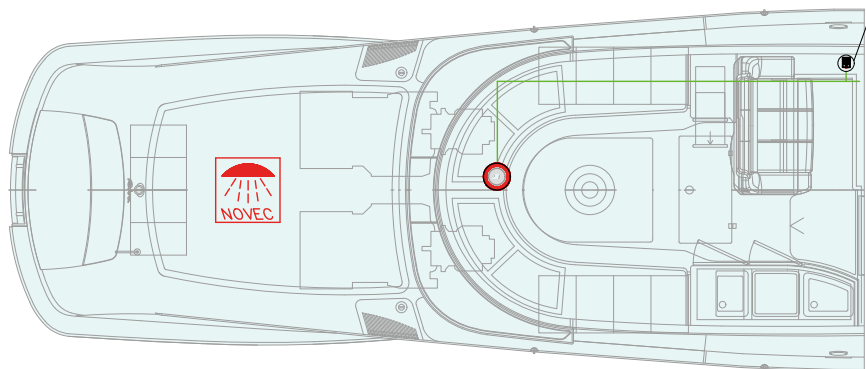
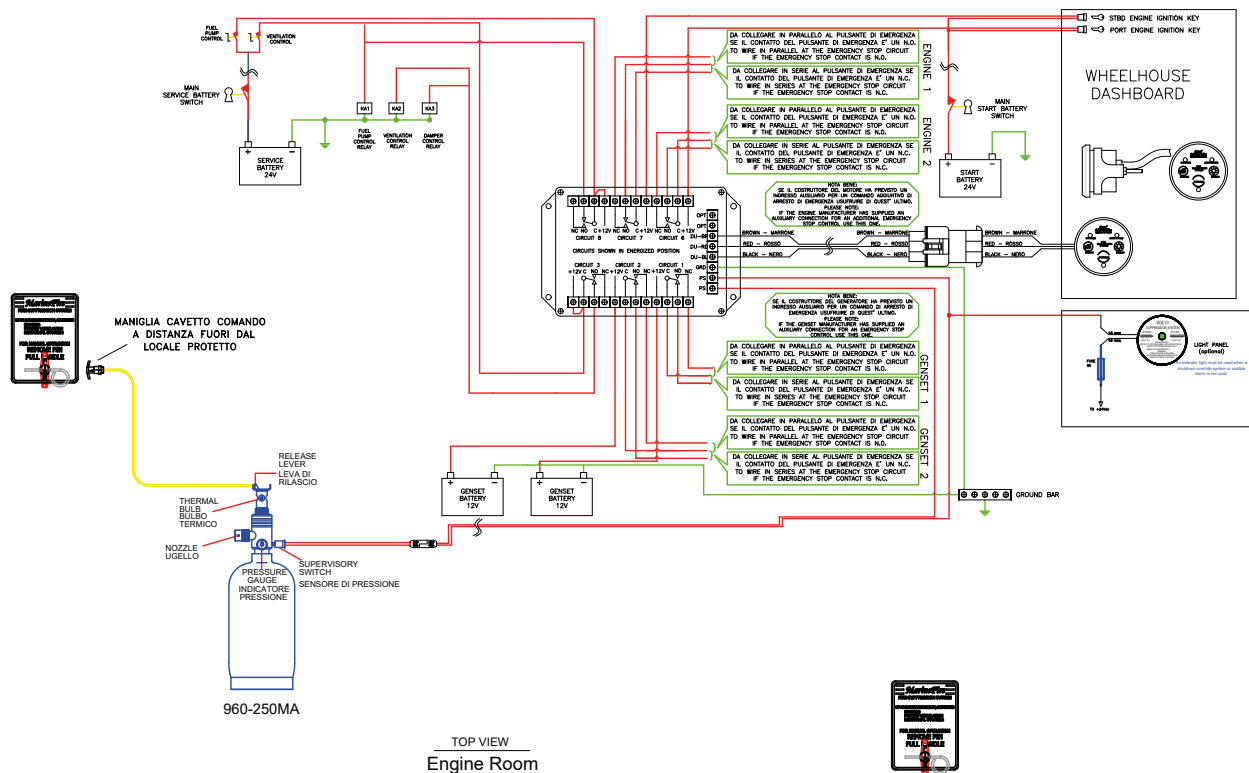

ICONA ICON	DESCRIZIONE DESCRIPTION
	Spazio protetto da NOVEC Space protected by NOVEC
	Allarme acustico e luminoso Acustical and flash alarm

2.7.2 Maintenance engine compartment fire protection system

Have the system overhauled by a qualified service centre according to the manufacturer's instructions.

Check the discharge indicator before use, to make sure that the fixed fire-fighting system has not been discharged.

Check the status of the fire prevention system from the helm position control panel (green charge light ON).

The fixed fire prevention system must be examined at least once a month and in any case before each journey to sea.

- For corrosion.
- To ensure that access to the controls is not obstructed.
- To ensure that the cylinder is securely positioned.
- To ensure that the pull cable is not broken, slack, damaged or kinked.
- To make sure that the cable connections are fastened properly.
- To make sure that the system has not discharged.



CAUTION

The extinguisher CONTAINS TOXIC CONCENTRATED CHEMICAL AGENTS AND SUB PRODUCTS FOR FIRE FIGHTING. Avoid inhaling fumes or long exposure to them.

THE ACCIDENTAL DRAIN DURING USE OR INSTALLATION CAN CAUSE SERIOUS INJURIES. Never let it drop down. Keep it far from extreme heat.



DANGER

The presence of the safety pin inserted prevents the activation of the manual discharge (by means of tie rods).



CAUTION

Carefully read the instruction manual. Before attempting any installation, removal, activation or maintenance of this device.



CAUTION

During maintenance operations, pay attention not to break the flasks unintentionally, in order to prevent accidental cylinder releases.



CAUTION

Check that at environment temperature the cylinders pressure gauge is set to correct actuation position indicated by the supplier.

MAINTENANCE

At least once a month, and in any case, before each navigation, check the charge status of the fire extinguisher.

At least once a month, and anyway before each navigation, check the external condition of the fire extinguisher. At least every 6 months check the fastening of the fire extinguisher.

Component	Maintenance	Notes and precautions
HFC227 gas fire extinguisher	Checks and tests	<p>Check the charge status by means of the pressure gauge installed on the cylinder. The charge status can also be checked also by measuring the cylinder weight.</p> <p>The extinguisher is properly charged when the pressure and weight values comply with the specification reported on the extinguisher tag.</p> <p>Before installing, weigh the extinguisher (bracket excluded) and record the date and weight on the special tag.</p> <p>Check the weight (bracket excluded) every six months: if the weight has decreased with respect to the previous checks, recharge or replace the extinguisher.</p> <p>Have the preservation status of the container (cylinder) checked by qualified technicians at least at the beginning of each season.</p>



DANGER

Accidental discharge of the fire extinguisher during handling or installation may cause serious injury. Insert the safety pin on the valve again until the installation or the check has been completed.
Protect your eyes during maintenance and installation operations.



DANGER

Once maintenance and installation have been completed, remove the safety pin from the extinguisher valve.



DANGER

During maintenance operations, pay attention not to unintentionally break the flask, because, even if the safety pin is inserted, if the flask breaks, the fire-fighting system activates.

2.7.3 Essential restoring for resuming navigation

If the fire-fighting system of the engine compartment has been activated and a fire has been extinguished, it is necessary to restore the essential conditions for navigation, in order to autonomously reach the nearest harbour in which to carry out the due checks.

To resume navigation, the ventilation system of the engine compartment and the fuel system of the propulsion engines must be brought back to normal working condition.



DANGER

Restoring the fire-fighting system with the aim of resuming cruising is an advisable operation only when the fire has not caused damage to the structure or to critical systems of the yacht.

In such a case, or should you have any doubt, it is essential to wait for rescue without resuming navigation.



DANGER

The operations for restoring the fire fighting system must be carried out directly from the engine compartment; therefore, before carrying out any operation, carefully read the safety instructions reported in the this manual.



CAUTION

Once the fire prevention system is restored, the extinguisher will be empty and no longer effective in the event of fire.

Once back in port, the fire extinguisher must be recharged by authorised personnel.

2.8 ALARM DEVICES

High temperature detection system installed on the yacht is an essential surveillance component for preventing any fires that may occur during operation.

This system consists of a detector positioned in the engine compartment. In the event of high temperature in the engine compartment (above 57°C), the detector activates the alarm siren and the light located on the helm position.

The temperature detection system is directly connected to the batteries, allowing its operation also while the yacht is left unattended and when the battery breakers are OFF.

2.9 NAVIGATION LIGHTS AND DAYLIGHTS SIGNALS

2.9.1 Navigation lights

The rules relevant to the navigation lights must be observed from sunset to dawn and during this period no other lights must be visible except the lights that cannot be exchanged for those specified in this manual.

Although the lighting system is preset by the Manufacturers, the Owner/Captain has the responsibility for the observance of the local rules.

Please note that the local and international rules relevant to lighting can slightly vary, we suggest therefore to gather information about the local rules of your area.

Night navigation requires more precaution.

All rules are applicable but apart from the right of course, it is advisable to slow down and to keep the proper distance from other boats.

It is a good rule to remember that bright lights reduce visibility at night.

Red/green lights (red to port, green to starboard)

Visibility range 112° 30' each.

Shown by any moving yacht and caused by any reason.

Anchor riding light (white)

Visibility range 360°, can be seen from any point of the horizon.

Seen from every anchored or under navigation yacht, or in specific circumstances.

The anchor light is stowed inside engines compartment when not in use.



CAUTION

The positioning of the navigation lights is optimised by adapting the regulatory requirements to the geometry of the yacht, providing lights where they are most easily visible.

Non-steering lights (N.U.C. = Not Under Control) and a bell are not included in the on-board equipment.

The fitting of lights and sound signals is subject to the approval of the Flag Administration where the yacht is registered.



WARNING

Navigation lights, shapes and sound signals.

Where navigation lights, shapes and sound signals are installed, they must be in conformity with COLREG 1972 (II International Regulations for Preventing Collisions at Sea) or CEVNI (European Code for Inland Waterways). Regulations depending on the case.

MAINTENANCE

At least once a week check the operation of the navigation lights.

At least once a week carry out accurate cleaning of glasses and headlights.

At least once every six months check the presence of corrosion in the connections of the navigation light cables.

At least once every six months, tighten the cable connections of the navigation lights.

The use of lights during the various situations of use of the yacht during night navigation are illustrated below:

- **Navigation:** red/green lights and anchor light ON.
- **At anchor:** anchor light ON.



CAUTION

For the use of navigation lights, the installation of the mast with the anchor light is required. It takes over the function of the mast head and stern light at the same time during navigation.



CAUTION

Solvents may damage the lens of the navigation lights. The lights must exclusively be cleaned with fresh water not containing solvents or abrasive substances. Remove the bulbs before the application of any paint.

NOTE

Before undertaking any navigation, the Captain should make sure that all navigation lights are operating correctly. Use the navigation lights in compliance with the regulations in force.

In order to install the anchor light mast, remove the plug of the support base, located on the main deck fore of the windscreen; be sure to store it in a safe place.

Fully insert the lights mast into the base of the support, making sure that the contacts in the base and in the lights mast coincide; check that the red/green lights are directed towards the bow perpendicular to the axis of the yacht.

To supply the navigation lights (red/green lights and anchor light), it is necessary to activate the button located on the panel in the helm position. The helm position carries the switch of the navigation or anchor riding lights. The navigation lights are provided with a ventilation system used to allow compensation and humidity escape. The ventilation system must not be clogged with grease, dirt or other materials.

The anchor light mast is normally placed in the engines compartment, with suitable hooks.



CAUTION

When the light mast is removed from its navigation position, store it onto the dedicated supports. Never leave the support base (electric connection) uncovered, but completely insert the relevant cover cap.



DANGER

During the installation operations of the anchor light mast, proceed with care on the main deck, side walk-arounds, because of the slippery surfaces.



CAUTION

The lights must exclusively be cleaned with fresh water not containing solvents or abrasive substances. Solvents may damage the lens of the navigation lights.



DANGER

Never use the lights mast as a handhold.

2.9.2 Daylights signals

In order to increase the safety of people on board, the manufacturer has provided the installation of a mast for daytime shapes, in accordance with Directive 2013/53/EU.

NOTE

The combined use of shapes, sound signals and navigation lights increases the visibility of the yacht, reducing the risk of collisions.

Daytime signals have the same function as navigation lights but are more visible during the day than navigation lights.

Depending on the situation, appropriate signalling templates shall be used.

Hereunder is a list of the most common ones to adopt after installing the relevant mast:

- Boat at anchor:



- Non-steering boat:



- Stranded boat:



- Boat with limited manoeuvrability:



- Boat to trailer or towed:



Navigation lights, sound signals and daylight signals

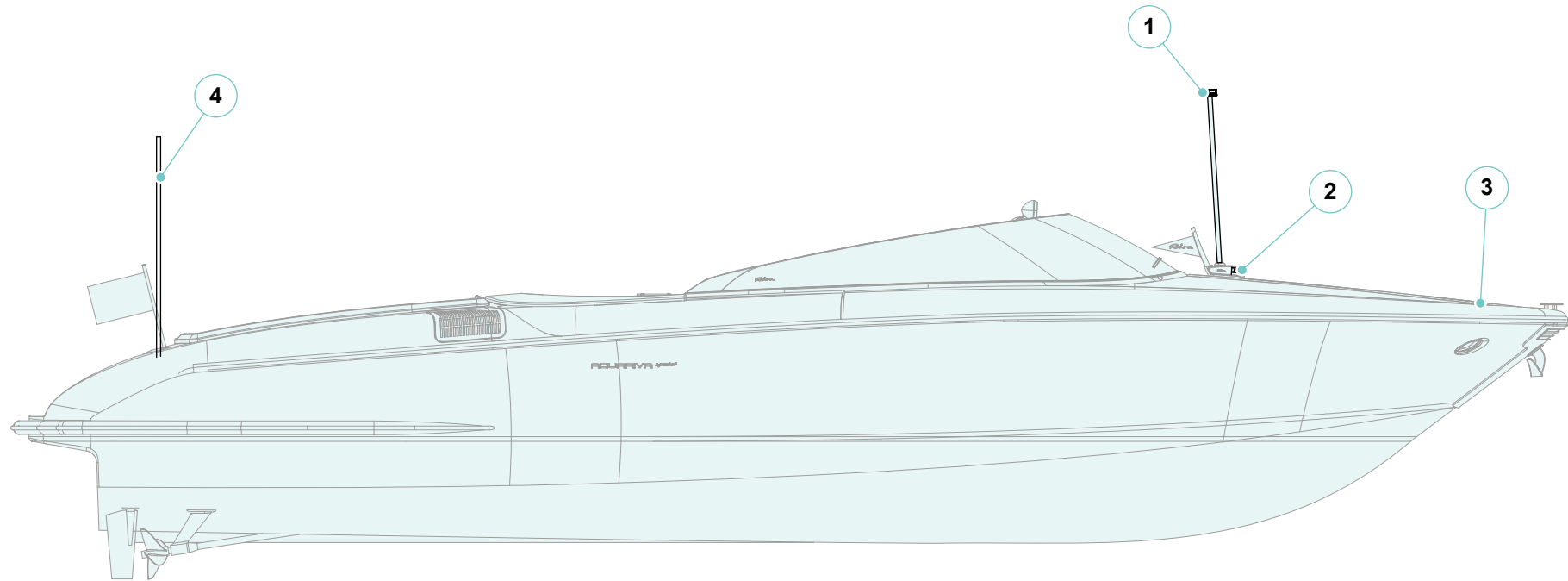

ICONA ICON	DESCRIZIONE DESCRIPTION	VISIBILITÀ DESCRIPTION
1	Fanale di fonda 360° White anchor light 360°	2 nm
2	Fanale bicolore rosso / verde 2x112,5° Bicolor red/green navigation light 2x112,5°	1 nm
3	Fischio elettromagnetico Electromagnetic whistle	/
4	Albero segnali diurni Mast daylight signals	/

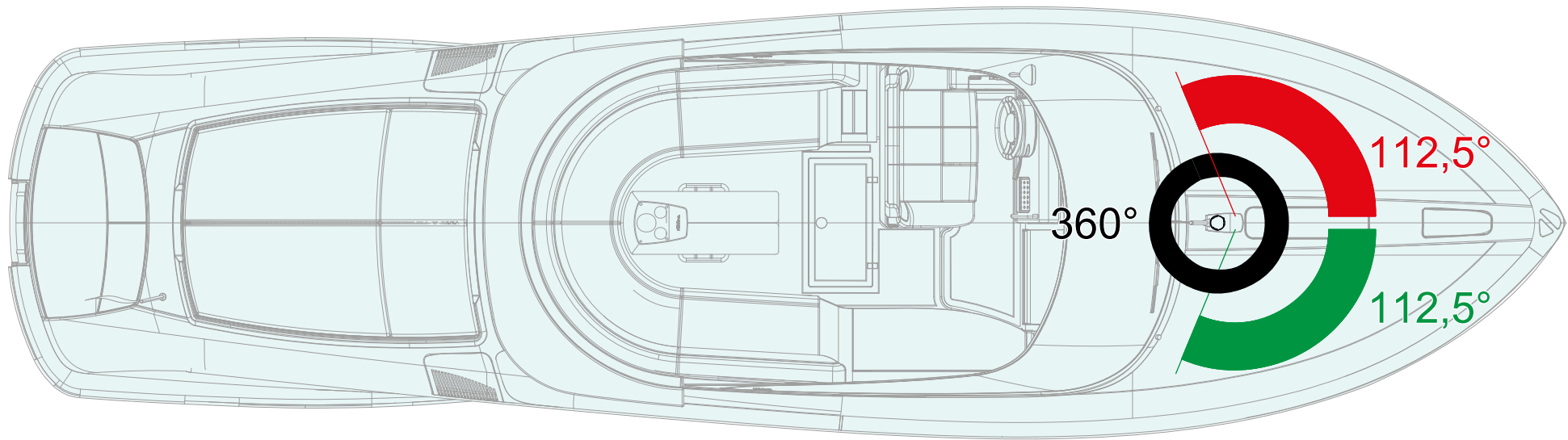

ICONA ICON	DESCRIZIONE DESCRIPTION
R	Rosso Red
B	Bianco White
V	Verde Green

2.10 MANDATORY SAFETY EQUIPMENT

In order to ensure proper safety conditions of the yacht, the Owner is obliged to maintain the yacht in good working order and state of repair, as well as to provide for the replacement of equipment, life-saving equipment and safety equipment that present deterioration or defects that may compromise proper function.

In addition to the equipment provided by RIVA, the Owner is responsible for providing the yacht with any further system and safety/marine equipment required by the rules in force in the nation where the yacht is used, according to weather and sea conditions and to the distance from safe harbours along the intended course.



DANGER

Rescue equipment must be arranged so as that when it is launched there are no obstacles to free floating and must be equipped with proper fitting allowing for quick release from the yacht when at sea.
The Owner is responsible for equipping the yacht with some of the equipment listed.

NOTE

Refer to the local Port Authorities for instructions and changes of the Safety Rules in force in the country where you are.



WARNING

The safety systems must comply with local and international navigation laws and must be periodically reviewed by specialised companies within the dates indicated on the systems themselves.

2.11 LOCATION OF SAFETY PLATES

The plates applied on the yacht are used to point out special risks: each plate is located on the part of the yacht which can be a source of risk. Before working with or on this part of the yacht, read the safety warning carefully.

Keep all the plates clean and readable, replace them if missing or damaged.

The extinguisher positioning plates are located close to the extinguishers.



CAUTION

It is prohibited to remove or damage the safety plates on the yacht.

2.12 SCHEDULE

Minimum rescue facilities and safety equipment to be kept on board of yachts and pleasure yachts with no limit of distance from the shore and with expiry date.

	2027	2028	2029	2030	2031	2032	2033	2034	2035
Self-inflatable life raft (for all persons on board)									
Individual life buoy (for each person on board)									
Life jacket with rope (floating type)									
Light buoy									
Smoke buoy									
Red light hand fires									
Red signal rockets with parachute									
Compass and deviation schedules									
Nautical charts									
First aid kit									
RTF inspection									
Property tax									
Insurance									
License (pilot)									
Portable fire extinguishers									
Fixed fire extinguisher in the engine compartment									
E.p.i.r.b.									



Riva

AQUARRIVA *special*

Riva

AQUARRIVA *special*

DESCRIPTION OF THE YACHT

CHAPTER 3

3.1 MAIN DIMENSIONS AND CHARACTERISTIC DATA

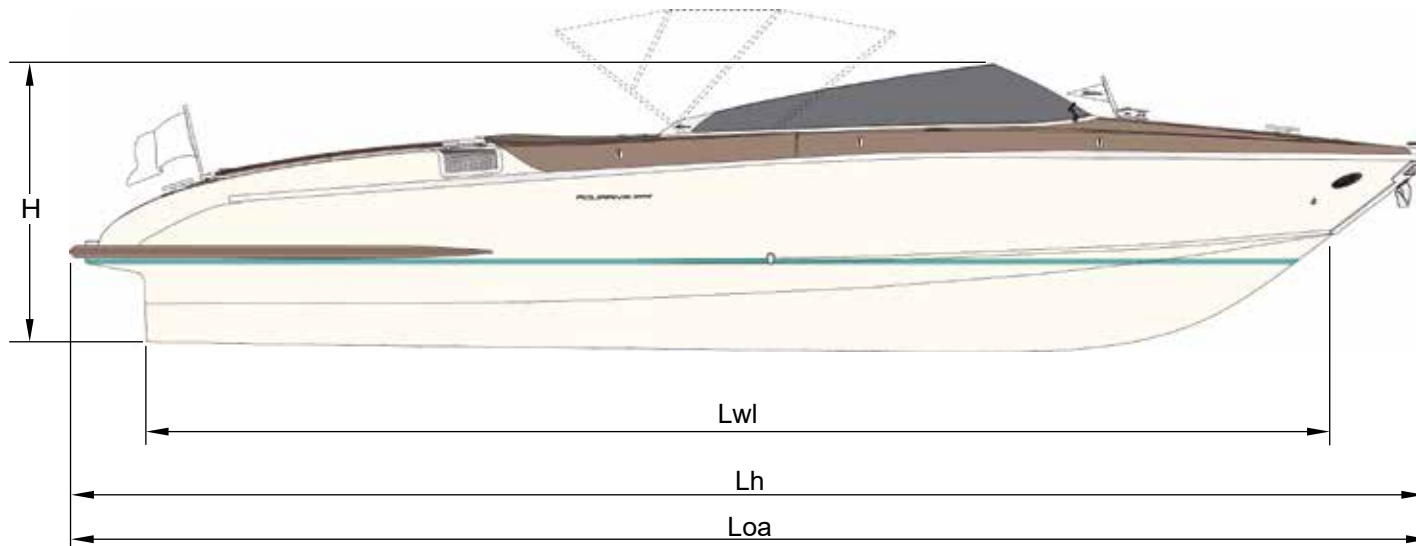

(Loa) Overall length	10,07 m	33 ft 0 in
(Lh) Hull length	9,92 m	32 ft 7 in
(Lwl) Waterline length (boat fully laden)	8,40 m	27 ft 7 in
Maximum beam	2,80 m	9 ft 2 in
(H) Overall height from keel to windscreen	2,22 m	7 ft 3 in
Pulpit and stern platform	0,15 m	0 ft 6 in
Depth under propellers (boat fully laden)	0,96 m	3 ft 2 in
Displacement unladen	5200 Kg	11464 lbs
Displacement laden	6700 Kg	14771 lbs

Technical data		
Hull type		16.5° deadrise variable convexity monohedron hull with spray rails
Construction material		GRP
Propulsion	Model	Yanmar 8LV-370
	Configuration	8 V-cylinders
	Power	370 mhp (272 kW)
	rpm	3800
	Dry weight	435 kg (959 lb)
Inverter	Displacement	4,46 lt (272 cu.in)
	Model	ZF90IVTS
	Fuel tank capacity	(lt) approximately 480 lt - 127 gal
	Water tank capacity	(lt) approximately 130 lt - 34 gal
	Black water tank capacity	(lt) approximately 36 lt - 9,5 gal
Total weight of liquids (full tanks)	(kg) approximately 646 kg (1424 lb)	
On board electric power supply	(V)	230 V single phase shore power
	(V)	12 V from batteries
Batteries	Engines (n°)	2 x 12V 134ah
	Services (n°)	1 x 12V 134ah
Bilge pumps	Engine compartment (n°)	2
	Cabin (n°)	1



CAUTION

RIVA yachts are designed to obtain a correct transversal trim with full optional equipment, as well as spare propellers and shafts.
If the yacht is not provided with full optional and with spare propellers and shafts, some weights are inserted to correct the transversal trim.
The above-mentioned weights can be removed or displaced as soon as the yacht is provided with a new equipment.



CAUTION

Bilge water should be kept to a minimum.
Stability is reduced by any weight added high up.
In the event of rough seas, doors, cabinets and doors must be closed to reduce the risk of flooding.
Breaking waves are a serious stability hazard.

NOTE

The technical specifications and the performances indicated are merely indicative, do not constitute an offer with the value of a contract in any way, and are referred to standard models of the motor yachts built by the Shipyard in the European version.
The only technical indications or descriptions with contract value for the purchaser are those relevant to the specific yacht purchased and contained in the sale documents.



WARNING

When loading the yacht, never exceed the maximum recommended load.
Always load the yacht carefully and distribute loads appropriately to maintain design trim (approximately level).

3.2 GENERAL YACHT LAYOUT AND SECTORS

This chapter contains a general description of the yacht and is supported by a set of illustrations thanks to which it is possible to easily locate the main areas and the different devices.

Advice and information on the correct use of the various instruments are also given.

The structure of the yacht has been divided as follows:

- Main Deck;
- Lower Deck;
- Engine compartment.

The yacht is provided with both electronic and mechanical devices and instruments; some of these are provided with their own user's manuals.

The information contained therein are an integral part of this Owner's Manual.

3.3 MAIN DECK

The main deck consists of a large outdoor area for open-air leisure.

The spacious, comfortable sofas in the cockpit and the aft sundeck are fitted with outstanding accessories.

Along with the areas designed to ensure optimal comfort for owner and guests, the main deck contains utilities and equipment for navigation, mooring and anchoring.

1. Means for re-boarding
2. Shoreside waste water discharge outlet
3. Shore electrical connection and fresh water fill inlet
4. Aft sundeck and access door to engine compartment
5. Port fuel fill inlet
6. Bimini seat cover
7. Cockpit sofa
8. Captain's seat
9. Adjustable spotlight
10. Helm position
11. Cabin hatch
12. Anchoring zone
13. Cabin access companion hatch
14. Service cabinet
15. Up/down cockpit table (optional)
16. Starboard fuel fill inlet
17. Raft compartment
18. Attachment ring for water skiing
19. Stern mooring cleats
20. Utility cabinet

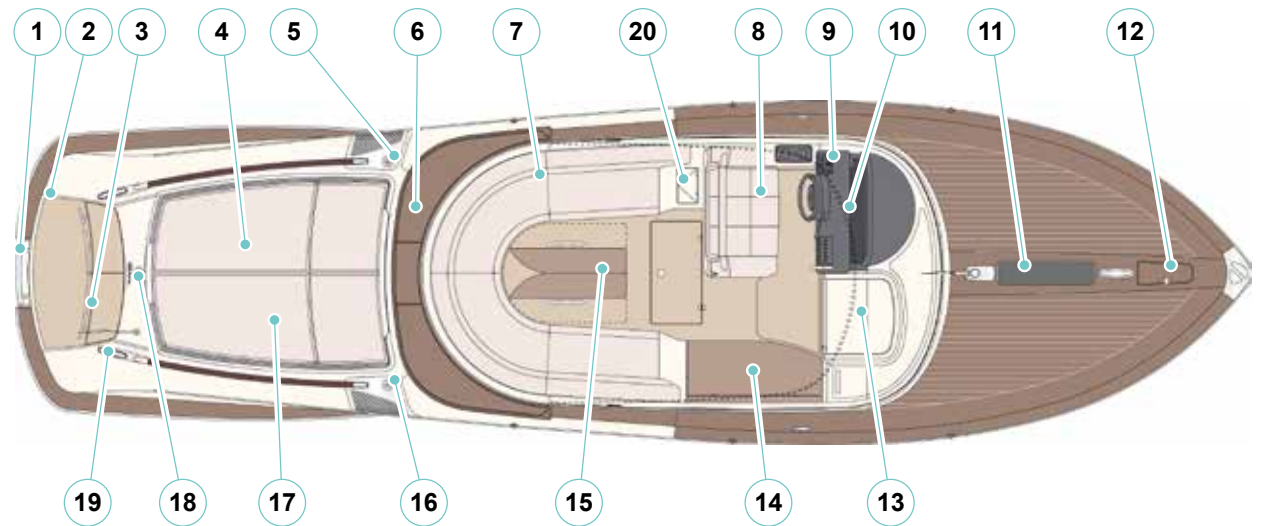

Riva

The cockpit area of the main deck contains a large area richly furnished for the social and convivial life of the Guests.

A comfortable sofa extends across the entire deck width with an interposed table.

The position of the cockpit table can be adjusted using the buttons on the helm position.

Lowering the table creates a sunbathing area in the cockpit.

Your yacht is equipped with an electrohydraulic bimini that serves as a sunshade for the cockpit when opened.

Movement of the bimini is controlled from the buttons on the helm position.

The cockpit zone is provided with important safety devices.

Under the cushions of the port cockpit sofa, for of the life raft storage peak, there is a compartment containing the individual life jackets.

To reach the life jackets, after removing the cushions, it will be necessary to lift the fibreglass panel by means of the relevant recess.



CAUTION

While removing the mobile parts described above, pay special attention not to hit and/or scratch the yacht.

Also pay attention in order to prevent passengers from standing in dangerous areas, especially in the area where operations are being carried out.

AQUARRIVA *special*

Fore of the cockpit there is the helm position, where all main yacht steering and control instruments are installed.



All manoeuvres, operations, navigation control, telecommunications and surveillance of the yacht are conducted from the helm position.



DANGER

Only allow authorized and qualified personnel to use the devices installed in the helm position.

The personnel operating the yacht during the various activities on board must not be under the influence of alcohol, drugs or narcotics.



Riva

The companion hatch, located between the helm position and the starboard side service cabinet, provides comfortable stair access to the cabin.

At the far end of the bow there are the necessary equipment for anchoring and mooring, and a wide peak containing the anchor chain.

AQUARRIVA *special*

Towing hook for water-skiing

The towing hook (1) has been installed on the aft transom for water-skiing.

The towing hook has been carefully dimensioned for water-skiing only, it is forbidden to use it for other purposes.



DANGER

Access to the sun-deck is not allowed while underway.

Water-skiing must be practised only during the day, with calm sea and under favourable weather conditions, keeping a distance of more than 200 m (656 ft) from the 1360 M.M. line in front of the beaches and more than 100 m (328 ft) from cliffs dropping sheer to the sea.

The captain must always keep their eye on the towed skier by means of the rearview mirror, and must always be assisted by another expert swimmer. During the different phases of the exercise, the distance between the yacht and the water-skier must never be lower than 12 m (39 ft). The start and stop of the water-skier must be carried out only in waters free from swimmers and yachts, i.e. inside the relevant corridors; the side safety distance between a yacht towing a water-skier and the other swimmers must be higher than the length of the towing cable.



DANGER

It is forbidden to tow more than two people at a time.

NOTE

We recommend reading the rules regulating water-skiing before practising it.



3.4 LOWER DECK

From the cockpit, the companion hatch and stairs give access to the cabin.

The cabin is composed of a double bed that occupies the entire fore section. The toilet is located beneath the bed.

Beneath the aft sundeck are electrohydraulic doors giving access to the engine compartment.

1. Cabin access companion hatch
2. Cabin bed
3. Toilet
4. Engine compartment



3.5 ENGINE COMPARTMENT

The engine compartment can be accessed through the hatch located under the stern sun decks.

The hatch is electrically operated and activated using the buttons on the helm position.

To supply the hatch push-buttons, it is necessary to activate the magneto-thermal switch located on the 12V utility electrical panel.

The engine compartment has been arranged as tidily as possible with machines and pipes, by installing the auxiliary machinery as far as possible on resilient, to absorb vibrations.

The engine compartment is provided with a watertight bulkhead; all tube passages towards the bow, and vice versa, are installed on the watertight bulkhead.



CAUTION

Entry into the engine compartment is permitted only to authorised personnel who are familiar with the operation of the installed components.



DANGER

The high operating temperatures of the engines create very hot areas within the engine compartment which maintain a high temperature for extended periods of time. Before accessing the engine compartment, wait for these areas to cool and take all appropriate precautions.



DANGER

Access to the engine compartment is not permitted when under way.



CAUTION

Do not introduce any object/material into the engine compartment that may move freely in the event of heeling during navigation.

1. Fresh water tank
2. Engine seawater filter
3. Fuel pre-filter
4. Main engines
5. Marine inverter
6. Fuel tank
7. Waste water discharge pump
8. Waste water tank
9. Batteries
10. Fire extinguisher
11. Fresh water pump
12. Water heater
13. Fuel shut-off valve
14. Battery charger
15. Exhaust gas muffler
16. Service battery breaker
17. Engine battery breaker
18. Gyroscopic stabilizer (optional)

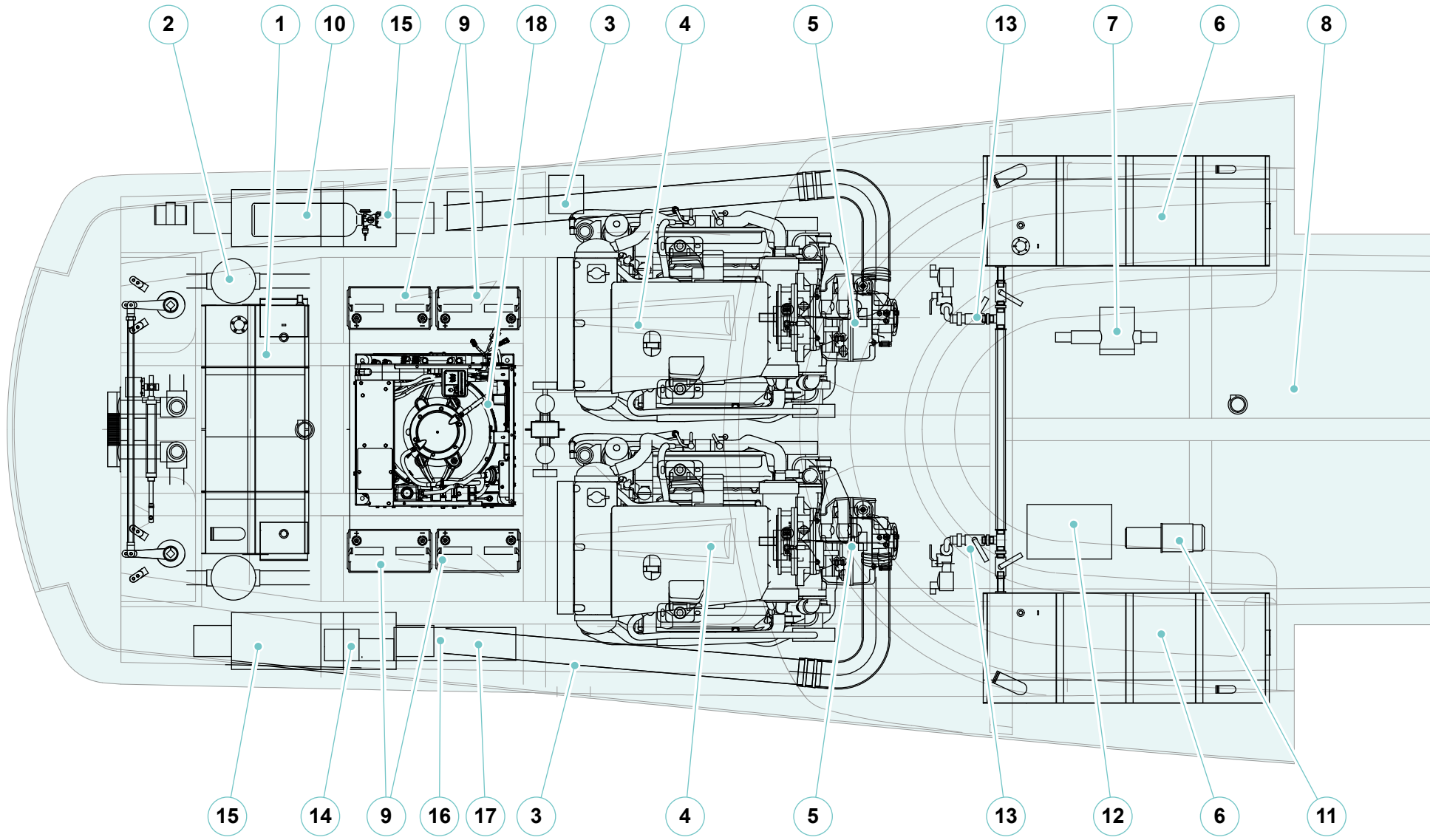

Riva

AQUARRIVA *special*

HELM POSITION

CHAPTER 4

4.1 HELM POSITION

Your yacht is equipped with a helm position located on the port side of the main deck.

The helm console is divided into four sections:

1. Upper section
2. Port section
3. Starboard section
4. Port side section



CAUTION

Herewith only general information for first start-up is given: in order to practice and for the specific use of the individual systems, see the manufacturers' manuals or contact RIVA After Sales & Service Department.



CAUTION

It is a good rule to keep the instruments clean by washing them with wet and clean rags, avoid using chemical products or abrasive ones. After navigation, it is advisable to cover instrumentation and equipment.



CAUTION

The helm position must be used only by the Captain or by the crew members authorised by the same.
The accidental activation of the controls installed in the helm position is a source of danger for the boat and its passengers.

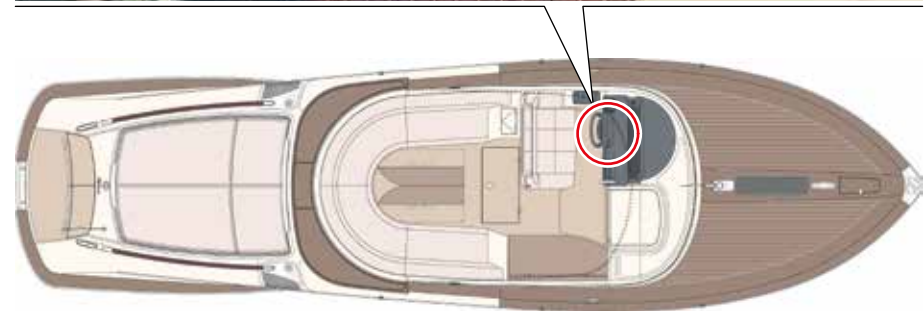



CAUTION

All electric appliances for navigation, whose parameters can be configured and set by software through the control panel, have been configured and tested upon delivery.

These operations must only be carried out by authorised technical personnel.

Any modification of the preset configurations can alter the operation and reliability of the concerned system.

Appliances must be used by the personnel in charge of driving the yacht and of using the systems.



CAUTION

Refer to specific manuals concerning the electronic and electric instrumentation on board.

Observe the instruction given meticulously.

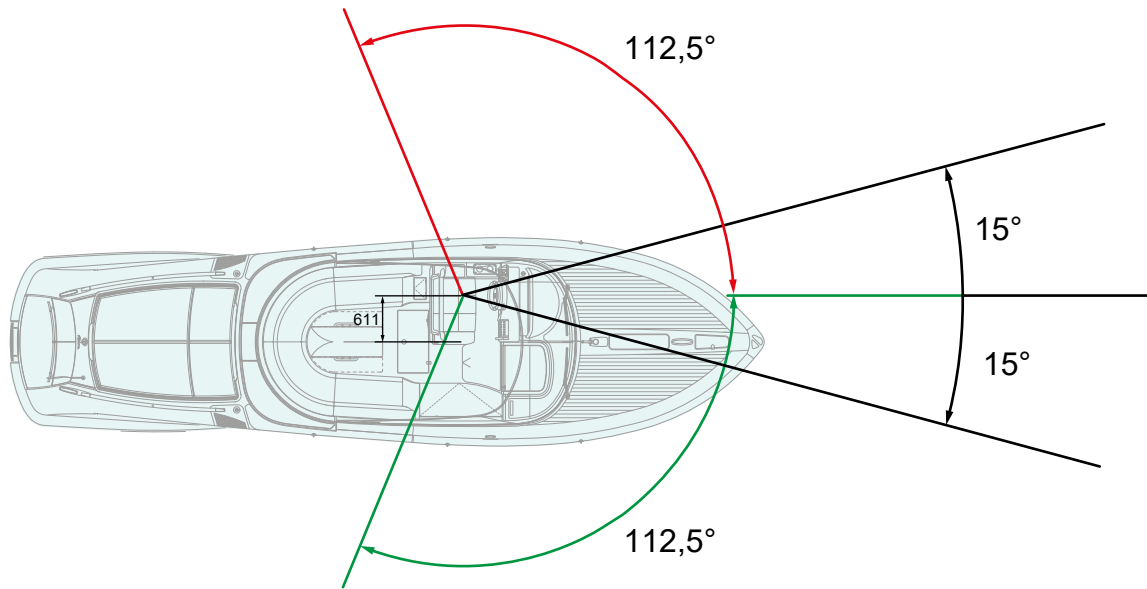
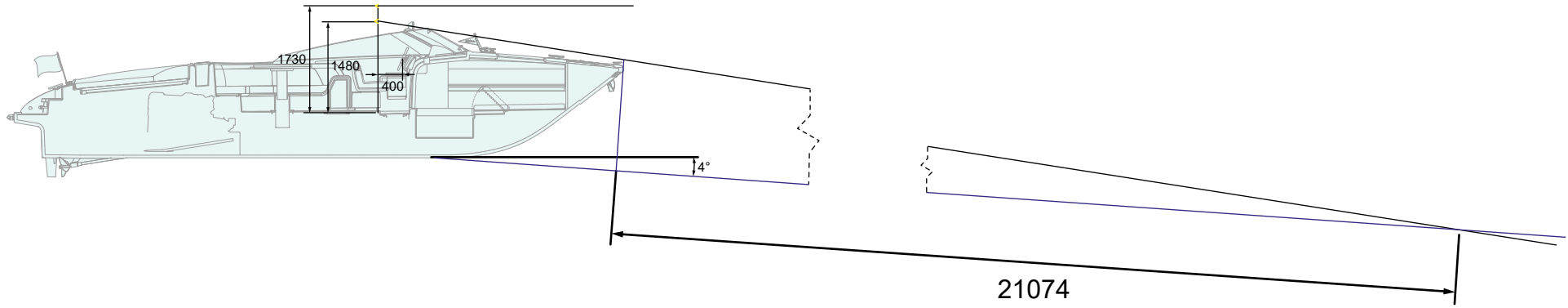

4.1.1 Upper section

Standard version:

1. Fresh water level indicator
2. Port fuel filter water alarm warning light
3. Port engine water thermometer
4. Port gearbox oil pressure gauge
5. Port engine oil pressure gauge
6. Port engine speed indicator with hour counter
7. Compass
8. Starboard engine speed indicator with hour counter
9. Starboard engine oil pressure gauge
10. Starboard gearbox oil pressure gauge
11. Starboard engine water thermometer
12. Port riser high temperature warning light
13. Fuel level indicator
14. Starboard riser high temperature warning light
15. Starboard fuel filter water alarm warning light

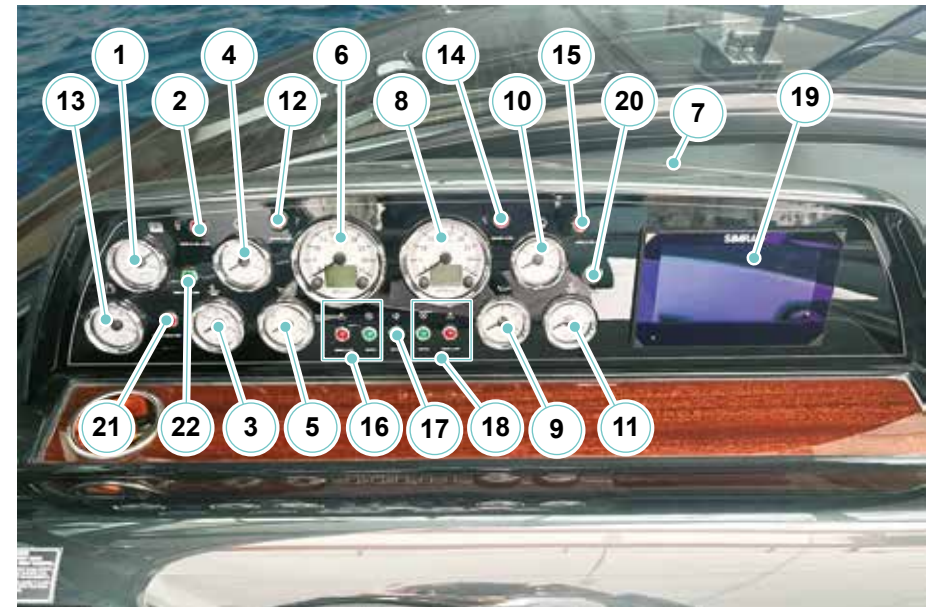

16. Port engine warning lights:

- Port gearbox neutral position
- Port engine alarm

17. Second speed warning light

18. Starboard engine warning lights:

- Starboard gearbox neutral position
- Starboard engine alarm

19. Chartplotter

This device allows displaying, in a clear and quick way, what is happening around the yacht, in order to facilitate navigation.

20. Engine compartment air extractor warning light

21. Bilge pump cockpit activation warning light

22. Freshwater pump activation warning light

Optional version:

23. Digital display



4.1.2 Port section

- 1. Engine sync activation push button**
- 2. Engine warm-up activation push button**
- 3. Port engine emergency stop button**
- 4. Starboard engine emergency stop button**
- 5. Port ignition panel, engine start and stop**
These allow the port propulsion engine to be switched ON and OFF.
- 6. Starboard ignition panel, engine start and stop**
These allow the starboard propulsion engine to be switched ON and OFF.
- 7. Steering wheel**
Allows you to steer the yacht.
- 8. Engine control levers**
Allow you to control the engines and inverters.
- 9. Battery parallel activation button**

NOTE

The electronic engine start system does not require the actual insertion of a key into the key slot, but it is only necessary to swipe the key (E-key) on the ignition panel of the engines.
For further information on use and maintenance, please refer to the manufacturer's manual.

- 10. Manoeuvring thruster activation push button**
- 11. Throttle push button**
- 12. Digital chain counter**



4.1.3 Starboard section

1. Hull lights activation button

Pressing the button activates the hull lights.

2. Cockpit lights button

Pressing the button activates the cockpit lights.

3. Engine compartment door open / close buttons

These allow you to open or close the access door to the engine compartment.

4. Bimini open / close buttons

These allow you to open or close the bimini.

5. Windlass operating buttons

These allow you to raise or lower the anchor.

6. Navigation lights activation button

Pressing the button activates the navigation lights (if installed).

7. Anchor light activation button

Pressing the button activates the anchor light, if installed).

8. Searchlight activation button

Pressing the button activates the searchlight.

9. Windscreen wiper activation button

Pressing the button activates the windscreen wipers.

10. Sound signal activation button

Pressing the button activates the sound signal.

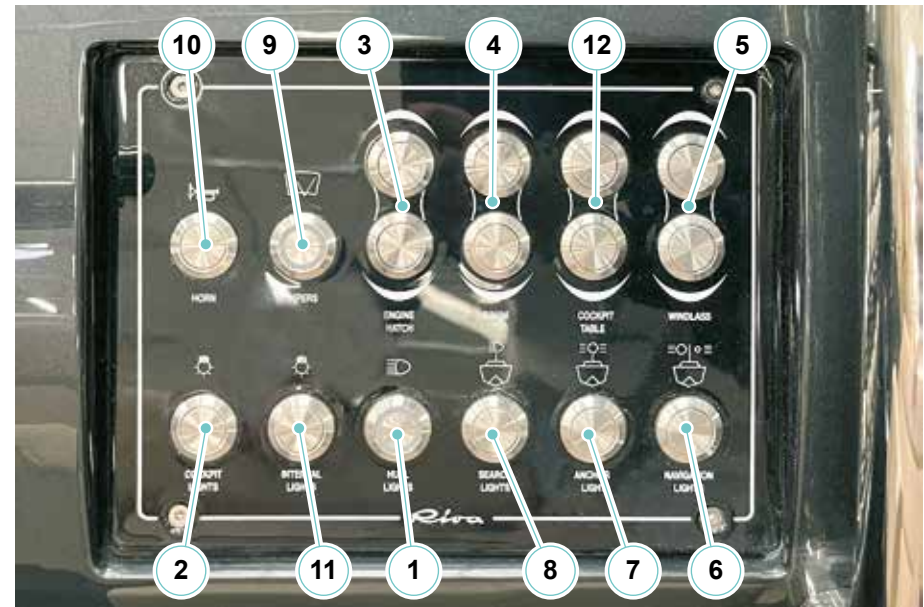

11. Internal lights activation button

Pressing the button activates the internal lights.

12. Cockpit table up/down buttons

Allow you to raise and lower the table in the cockpit.

4.1.4 Port side section

1. Bow bilge high water alarm light

Indicates the presence of high water in the bow bilge.

2. Engine compartment extinguisher charge status light

The light indicates the charge status of the extinguisher in the engine compartment.

- Light ON: extinguisher charged.
- Light OFF: extinguisher spent.

3. Engine compartment bilge high water alarm light

Indicates the presence of high water in the engine compartment bilge.

4. Bow bilge pump status indicator light

Indicates the status of the bow bilge pump.

- ON: pump running.
- OFF: pump not running.

5. Bow bilge pump activation button

Enables or disables the operation of the bow bilge pump.

6. Engine compartment fore bilge pump status indicator light

Indicates the status of the engine compartment fore bilge pump.

- ON: pump running.
- OFF: pump not running.

7. Engine compartment fore bilge pump activation button

Enables or disables the operation of the engine compartment fore bilge pump.

8. Engine compartment fore bilge pump status indicator light

Indicates the status of the engine compartment fore bilge pump.

- ON: pump running.
- OFF: pump not running.

4 - HELM POSITION

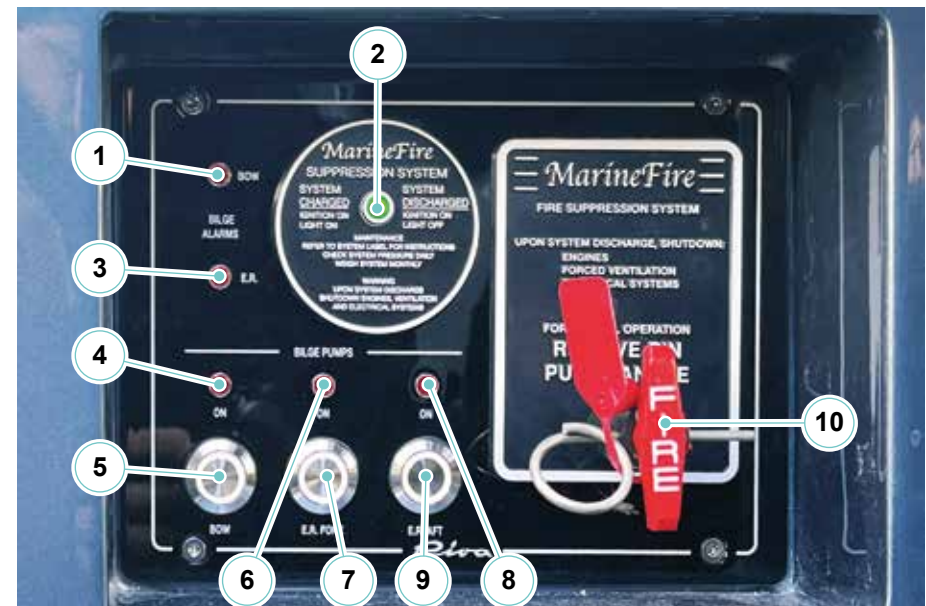
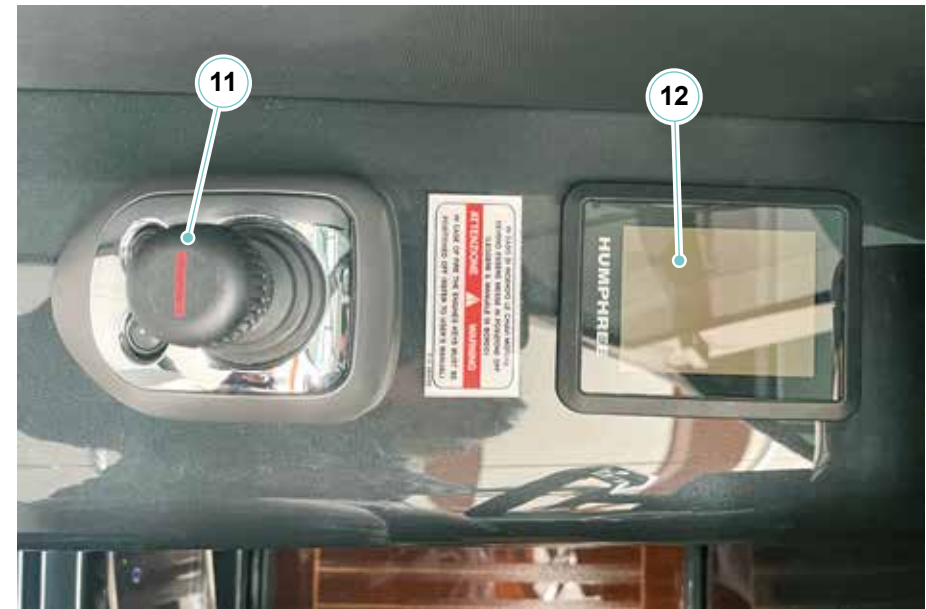

9. Engine compartment aft bilge pump activation button

Enables or disables the operation of the engine room aft bilge pump.

10. Engine compartment extinguisher discharge activation tie rod

Activates discharge of the fire extinguisher in the engine compartment.

11. Engines and thruster control joystick (optional)

It allows to manoeuvre at low speed by controlling engines and thruster separately.

12. Interceptor control panel

These allow to control the functioning of the interceptor.

4.2 INSTRUMENTATION

4.2.1 VHF-DSC Radiotelephone

The VHF device allows communication on channels dedicated to Port Authority, rescue and radio stations.

To ask for rescue it is necessary to use the suitable **VHF/FM** channel: after each hour, as a legal rule, follow 6 minutes of silence, from minute 0 to minute 3 and from minute 30 to minute 33, so as to enable a better listening of the distress communications.

If the VHF is used, the distress call must be preceded and ended by the wording "**MAYDAY, MAYDAY, MAYDAY**".

It is therefore necessary to give your position, the yacht's name, the kind of damage and the kind of help you require (medical, mechanical, etc..).



CAUTION

Perform the "**MAYDAY**" rescue call, only in case of real need.

If, listening to the distress channel, a distress call that has not yet received an answer is picked up, it is possible to send a "**MAYDAY RELAY, MAYDAY RELAY, MAYDAY RELAY**", forwarding the communication of the person who requested rescue.

It can in fact happen that the distress call, carried out on the open sea or by means of a poorly powered sender, is not received by the rescue team. Acting as a spokesman, you can help the message reach its destination successfully.



CAUTION

Perform the call "**MAYDAY RELAY**" only if there is a reasonable certainty that the message has not been collected by the rescue team so as not to engage the distress channel uselessly.

The use of the standard procedure avoids creating confusion and shortens the transmission time. In case of danger, use only the phonetic alphabet recommended.

The VHF device is a vital and important communication line; please remember some fundamental rules:

- No transmission should be performed without reason;
- Listen before transmission so as to avoid interference with other senders;
- For distress calls, use and hold the best possible wireless contact;
- Always use your call identification or the name of the yacht in order to make yourself identifiable. The use of names or family names is not allowed;
- Send short and clear messages;
- For distress calls it is important to give the yacht's position, the kind of danger, the time passed in water, the kind of yacht and the number of persons involved;
- For other calls, once the contact with the person called has been established, transfer the call on an operation channel;
- Cut out transmission if required by a coastal station;
- Retune the radio when the call is ended.

To use the radiotelephone:

- Turn the ON/OFF/volume control on the top of the radio clockwise.
- The radio will enter standby mode. This is indicated by the Amber LED flashing once every 5 seconds, signalling that the radio is ready for use.
- Adjust the volume control to select the desired volume level.
- Using the channel buttons ensure that the correct channel is selected.
- When a valid signal is received, the LED will light steady green and audio will be output from the radio speaker.
- When finished using the radio, switch it OFF by turning the ON/OFF/volume control until it clicks and the radio is switched OFF.

MANUAL DISTRESS CALL:

- Select the distress channel by pressing key 16/9 or by scrolling the channels with the volume keys.
- Press the transmission key (PTT) on the radiotelephone and make the call.

MAYDAY - MAYDAY - MAYDAY THIS IS:

Repeat the yacht's name for 3 (three) times.

MAYDAY THIS IS:

Repeat the yacht's name.

AT POSITION:

Specify the position of the yacht.

SPECIFY THE DISTRESS CAUSE:

- Release the (PTT) transmission key.
- Wait for the reply for a few seconds.
- If you do not receive any reply, repeat the message at regular intervals, until receiving a reply.
- When you receive an answer, continue the conversation:
 - Hold down (PTT) while talking.
 - Release (PTT) while listening.
- It may be required to switch to a working channel.

NOTE

For further information on use and maintenance, please refer to the manufacturer's manual.



WARNING

For the selection of channels and activation of the particular functions of the radiotelephone, please refer to the specific manual supplied by the manufacturer.

4.2.2 Engine control levers



The engine control levers are a system designed to manage the engine revolutions and the inverter gears by means of electrical signals.

With the levers to the central position, the engines turn at idle and the inverter is in neutral.

Moving the levers to the first level up engages the gear; moving the levers higher increases engine revolution, thereby increasing yacht speed.

The same procedure moving the levers downwards engages the reverse gear.

The aft lever controls the port engine; the fore lever controls the starboard engine.

NOTE

For further information on use and maintenance, please refer to the manufacturer's manual.

4.2.3 Steering wheel

The steering wheel is connected to a hydraulic pump which uses hydraulic drive systems (cylinders) to move the rudders.

NOTE

For further information on use and maintenance, please refer to the manufacturer's manual.

4.2.4 Chartplotter



CAUTION

The electronic chart is an aid to navigation, designed to facilitate the use of authorized steering charts, not to replace them. Only official steering charts and notices to mariners contain all information needed for the safety of navigation and, as always, the Captain is responsible for their proper use.

MAINTENANCE

At least once a week carry out the cleaning of the display.
At least once every six months check the connection and the presence of corrosion on the cables.

NOTE

For further information on use and maintenance, please refer to the manufacturer's manual.

4.2.5 Thruster control panel

The thruster control panel consists of an activation button (ON/OFF) and a bidirectional lever (starboard/port).

The joystick controls the 12V electric motor that rotates the bow thruster.

To make the thruster controls operational, the relevant magneto-thermal must be activated.

NOTE

Remember to disconnect the power supply of the system when manoeuvres are ended or during normal navigation.



DANGER

During the bow thruster operation, pay attention to possible swimmers or small yachts which may be close to the thruster tunnel.

Always stop the thruster before undertaking inspection or maintenance tasks by disconnecting the switches and possibly also the battery terminals.

NOTE

For further information on use and maintenance, please refer to the manufacturer's manual.

Riva

AQUARRIVA *special*

Riva

AQUARRIVA *special*

WATER SYSTEMS

CHAPTER 5

5.1 FRESH WATER SYSTEM

The fresh water system consists of a 130-litre tank (1) in the engine compartment.

The tank is filled by means of a gravity fill inlet (2), located at the stern of the yacht.

The freshwater filler cap is secured to the structure by a steel cable to prevent it from being lost or dropped overboard.

The tank is equipped with an air vent and an electronic level switch that transmits level indications to the corresponding instrument on the helm position.

From the tank, freshwater is sucked in by the autoclave pump (3), located in the engine compartment, through a suction line.

The autoclave, protected and powered by the magneto-thermal circuit breaker located on the main 12V utilities switchboard, ensures, with the help of a check valve, the continuous presence at constant pressure of freshwater throughout the system.

The supply of power to the autoclave is indicated on the helm position multifunction display.

A filter is installed upstream of the autoclave to prevent dirt and suspended particles from reaching the pump and potentially causing damage. Periodically check the filter and clean if necessary.

Downstream of the autoclave, the fresh water system is divided into two parts:

- Cold water;
- Warm water.

In the event of technical issues, please refer to the autoclave unit user manual or contact the service centre.





CAUTION

Before refilling the fresh water tank, check that the water supplied by the dock fresh water system is drinkable.



CAUTION

The fresh water circuit, and particularly the tanks, must be sanitized periodically by pouring in the case a specific disinfectant solution. We recommend in any case that the water coming from the on-board system not be drunk.



CAUTION

Regularly inspect the fresh water and bilge circuits for leaks. Repair any leaks by releasing the pressure in the system, in order to avoid damaging the furniture and the electrical equipment.



CAUTION

The pressure regulator at pumps output is set at the factory; do not modify.



CAUTION

The inlet plug is marked "WATER" to avoid accidental introduction of different liquids. To avoid damage to the system and tanks, we recommend replenishing by gravity and not by pressure.



WARNING

It is a good norm to optimise the use of water, especially if navigating at open sea!

Fresh water system diagram

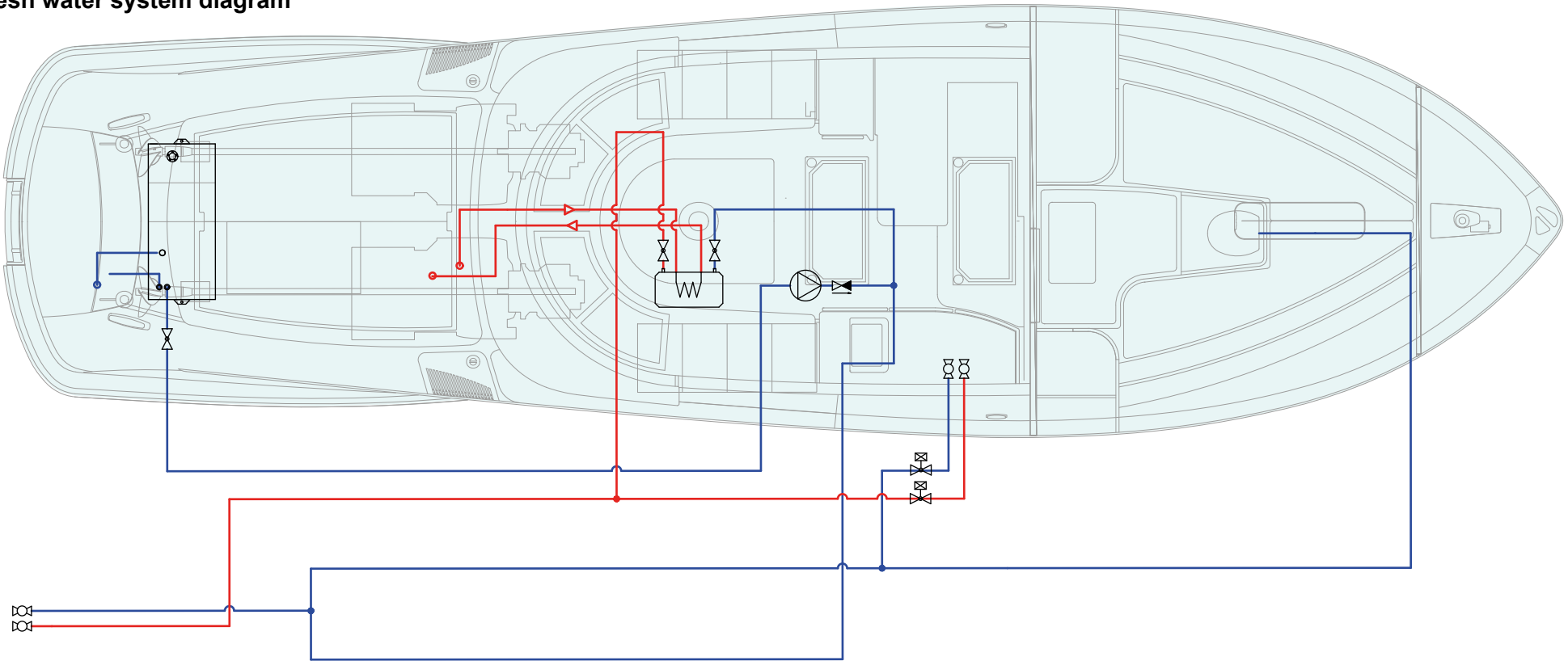

ICONA ICON	DESCRIZIONE DESCRIPTION
	Impianto acqua dolce fredda Cold fresh water circuit
	Impianto acqua dolce calda Hot fresh water circuit
	Valvola a sfera Ball valve

ICONA ICON	DESCRIZIONE DESCRIPTION
	Pompa Pump
	Rubinetto Tap
	Valvola di non ritorno Check valve

ICONA ICON	DESCRIZIONE DESCRIPTION
	Elettrovalvola Solenoid valve
	Boiler Water heater

5.1.1 Cold fresh water system

The system is kept under pressure by a autoclave pump.

The pump supplies the system by drawing water from the tank; the water flowing through pipes and manifolds supplies following services:

- WC;
- Windscreen wiper;
- Water heater;
- Cockpit sink;
- Stern shower.



WARNING

Before activating the system, ensure the proper position opening/ closing of the manifold valves: valve open, lever parallel to input hose, valve closed, lever perpendicular to input hose.

5.1.2 Hot fresh water system

The autoclave pump takes the cold water from the fresh water tank and sends it to the electric water heater, located under the cockpit.

Water contained in the water heater is heated via a heat exchanger fed with coolant from the main starboard engine. The water then reaches the following utilities:

- Aft shower;
- Cockpit sink.

The water inlet and outlet lines from the water heater can be shut OFF by means of ball valves.

NOTE

The water heater is not an accumulator: wait that goes up to temperature.



CAUTION



Periodically inspect the freshwater circuit and bilges to identify any leaks. Repair leaks by removing pressure from the system to avoid damage to furniture and electrical equipment.

The fresh water circuit, and in particular the tank, must be periodically sanitised by pouring a specialist disinfectant solution through the inlet nozzle.





NOTE

For further information on use and maintenance, please refer to the manufacturer's manual.

5.1.3 Maintenance fresh water system

Component	Maintenance	Notes and precautions
Fresh water tank	Inspection and cleaning	<p>At least every month, drain the fresh water tanks completely and rinse them a couple of times with clean fresh water for change completely the water stowed in the storing tanks and at the same time to wash them too.</p> <p>Periodically pour a specific disinfectant, in the quantity recommended by the Builder, into the tanks, through the intake filler, in order to prevent the formation of bacteria in the system.</p>
Fresh water system	Inspection	<p>In case of need or of maintenance, by acting on the valves installed on the distribution manifolds, it is possible to cut out parts of the system or single utilities, without involving the operation of the general system.</p> <p>Check if along the hydraulic circuit, where possible, are present leaks due to the damage of piping.</p> <div data-bbox="1070 762 2074 991" style="border: 1px solid orange; padding: 10px; margin: 10px 0;"> <p style="text-align: center;"> WARNING</p> <p>The high temperature can cause the softening of the pipes and the following slackening of the fittings. Always check the pipes tightening, especially those located near heat sources.</p> </div> <div data-bbox="1070 1034 2074 1225" style="border: 1px solid orange; padding: 10px; margin: 10px 0;"> <p style="text-align: center;"> WARNING</p> <p>During the winter, if you do not use the yacht, it is advisable to drain all the circuits where there is fresh water to avoid cracks due to frost.</p> </div>

Component	Maintenance	Notes and precautions
Autoclave pump	Inspection and cleaning	<p>The maintenance of the pump should be serviced by qualified personnel only, after having been disconnected from the power mains.</p> <p>No routine maintenance is required so long as the following precautions are taken:</p> <ul style="list-style-type: none"> • In case of freezing risk, it is necessary to empty the pump body; then refill the pump before operating it but make sure the ambient temperature is higher than the water freezing temperature. • Make sure the pump never works dry. • If the pump remains unused for a long time, it is better to empty the body and clean it. • Periodically check the efficiency of valves and filters, if any. • To Direct Current motors the brushes must be periodically checked for consumption and spring pressure. <p>Protect electric components of the pump with proper products.</p> <div style="border: 1px solid black; padding: 5px; margin-top: 10px;"> <p style="text-align: center;">NOTE</p> <p>For further information on use and maintenance, please refer to the manufacturer's manual.</p> </div>

Component	Maintenance	Notes and precautions
Autoclave pump	Inspection and cleaning	<div data-bbox="1077 268 2069 608" style="border: 1px solid orange; padding: 10px;">  <p>WARNING</p> <p>The surge tank pump is self-priming but it needs though, in order to operate, to have its body filled with liquid.</p> <p>For a correct use, we recommend priming first or after a long period of idling, to fill the pump body with liquid, to check the pressure inside the tank (it must have the same pressure priming the electric pump) and to verify the clockwise rotation of the pump (seen from the engine side).</p> </div> <div data-bbox="1077 651 2069 842" style="border: 1px solid orange; padding: 10px;">  <p>WARNING</p> <p>If the control panel shows the pump operating led remains always lit, but the connected utilities are not in use, check for leaks.</p> </div> <div data-bbox="1077 885 2069 1161" style="border: 1px solid orange; padding: 10px;">  <p>WARNING</p> <p>When anomalous situations occur, such as lack of water or pipes clogging, it indicates the presence of faults by means of the red light “Failure” and stops the pump.</p> <p>By pressing red button (reset) the system restart.</p> </div> <div data-bbox="1077 1204 2069 1390" style="border: 2px solid red; padding: 10px;">  <p>DANGER</p> <p>Before carrying out maintenance on the fresh water pump, avoid its accidental priming.</p> </div>

5.2 BLACK AND GREY WATER SYSTEM

The waste water system installed on board the yacht consists primarily of one 36-litre waste water holding tank located under the cockpit.

Grey waste water is collected inside the tank located in the bilge of the cockpit.

The sea discharges have been plugged.

The system vent is located on the port bow. Before being discharged outside, the vented air passes through a special filter to eliminate unpleasant odours.

The level switch in the tank analyses the water level inside the tank and sends alarm signals to the main electrical panel.

The electrical WC system is powered and protected by the circuit breaker located on the main electrical panel; this must be activated for the electrical toilet to operate.

A pump located underneath the cockpit empties the tank via a suction line which discharges directly into the sea through a drain below the waterline. The tank can be emptied by suction pumping from shore through the deck drain (1) located at the yacht's stern.

The three-way valve (2) in the engine compartment is used to select the method for emptying the waste water tank (sea or shoreside).

To start the pump, press the button on the main electrical panel.



**CAUTION**

Within 12 nautical miles from the coast it is forbidden to discharge the black water tank into the sea; it is necessary to keep the discharge pump inactive and to exclude the automatic activation.

The option of unloading the sewage tank at the quayside and transferring its contents to the on-shore sewerage system is the solution with the least environmental impact, which should be adopted whenever the yacht is moored in an equipped place.

**CAUTION**

Before leaving the harbour, check the indicators of level of the black water tank on main deck panel to perform, if necessary, the suction from the shore supply.

Before entering dock, you should check the tank level and decide whether you should discharge at sea or use the port facilities by checking in advance if the your destination port is equipped for tank emptying through the aft starboard nozzle.

**CAUTION**

During the suction black water from the dock is strictly prohibited to:

- Use the toilet;
- Activate the overboard discharge pump.

**WARNING**

Before use, make sure:

- Enabling the utility by setting the WC system magneto-thermal circuit breaker on the main switchboard to ON if necessary;
- The absence of the high tank level warning light.

**CAUTION**

It is advisable to routinely monitor the waste water level via the indicators on the main electrical panel in order to optimise usage of the holding system in accordance with local environmental regulations.

**CAUTION**

In case of sinking hazard, if escaping condition allow you this, close the ball valve of the black water drain.

**CAUTION**

Totally empty the system and the black water tank before the lay-up period in order to prevent any problems with freezing.

**CAUTION**

For all pleasure yachts, drain at sea of on-board toilets is forbidden inside harbours, landings and moorings dedicated to crafts' anchor riding, and also within the limit of beaches visited by swimmers, as stated in the single regulations of the Port Authorities.

**CAUTION**

Direct sea discharge can only be carried out in the event of an emergency.

**WARNING**

When using chemical products, follow the manufacturer indications meticulously and use the suitable protection devices.

**ENVIRONMENT**

According to the regulation in force concerning cruising on Swiss lakes, grey water discharge shall only occur by means of shore suction, through the special discharge outlet, after having operated the three-way valve located inside of the cockpit furniture under the sink, following the instructions shown on the special label.

Black water system diagram

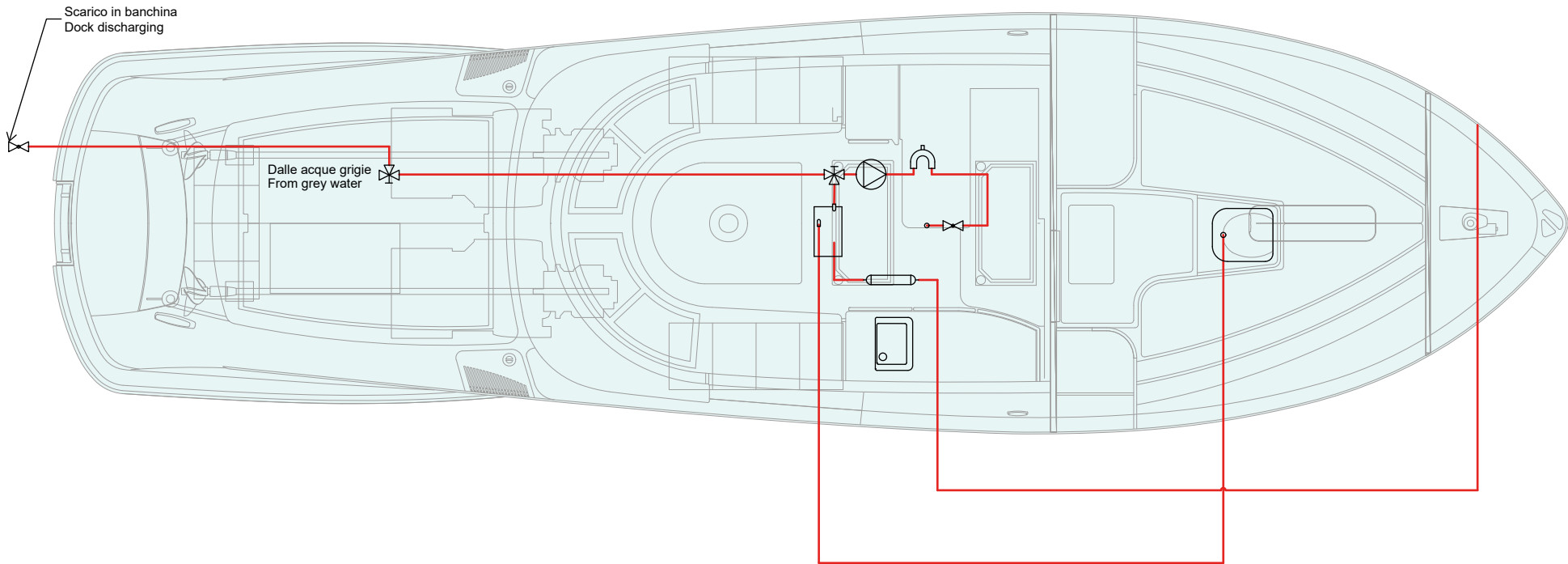

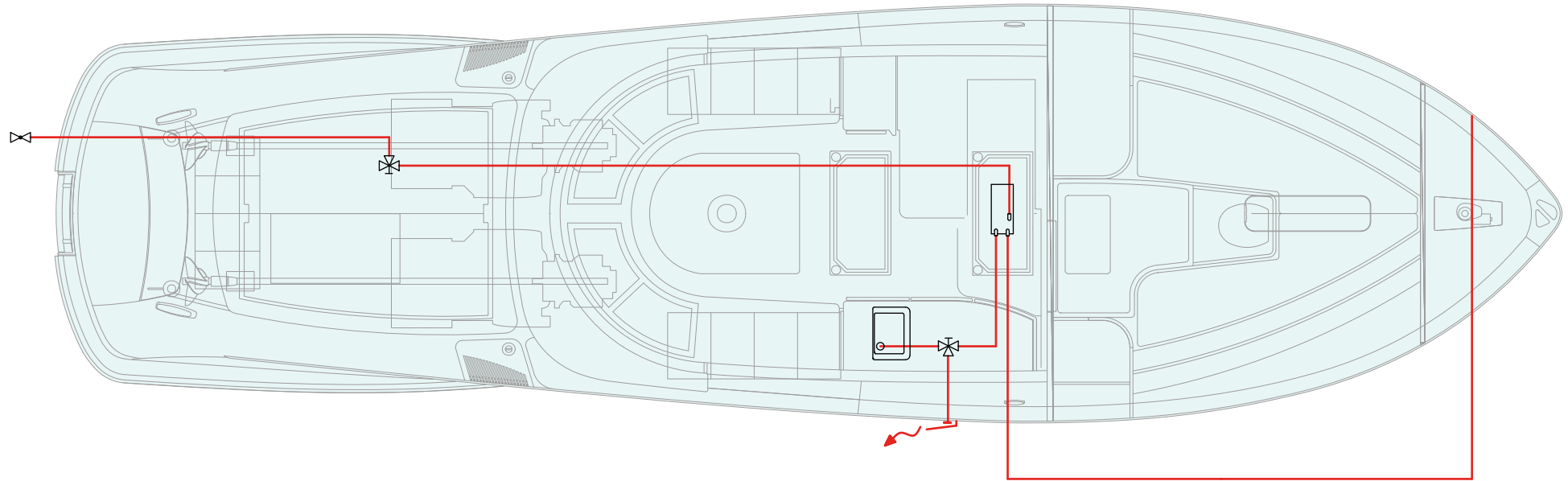

ICONA ICON	DESCRIZIONE DESCRIPTION
	Valvola a sfera Ball valve
	WC WC
	Elettropompa Electro pump

ICONA ICON	DESCRIZIONE DESCRIPTION
	Serbatoio del vuoto Vacuum holding tank
	Filtro sfiato Vent filter
	Curva di sfogo Vented loop



ICONA ICON	DESCRIZIONE DESCRIPTION
	Serbatoio acque grigie Grey water tank
	Valvola a sfera ball valve
	Valvola a sfera a tre vie Three way ball valve

5.2.1 Maintenance of black water draining system

Component	Maintenance	Notes and precautions
Waste water tank	Rinse the tank (at least once a month)	<p>Fill the tank with clean water and empty it two or three times. It is advisable to periodically pour a sterilizing product into the toilet drains in order to prevent the formation of bacteria and associated unpleasant odours.</p> <div data-bbox="1072 469 2074 660" style="border: 1px solid yellow; padding: 5px; margin-bottom: 10px;"> <p style="text-align: center;"> CAUTION</p> <p>Should deodorants or disinfectants be used, avoid abrasive substances or acids, because they could damage tubes and seals.</p> </div> <div data-bbox="1072 705 2074 896" style="border: 1px solid yellow; padding: 5px; margin-bottom: 10px;"> <p style="text-align: center;"> CAUTION</p> <p>In case of need, break or pollution of the tanks, they can be replaced. Contact the RIVA After Sales & Service Department.</p> </div> <div data-bbox="1072 941 2074 1313" style="border: 1px solid gray; padding: 5px;"> <p style="text-align: center;">MAINTENANCE</p> <p>At least once a week check the correct operation of the:</p> <ul style="list-style-type: none"> • Toilet; • Waste water pump. <p>At least once every 3 months check the condition of the pipes and fittings.</p> <p>At least once every 6 months treat with special protective products:</p> <ul style="list-style-type: none"> • The toilet solenoid valves; • The waste water pump. <p>Thoroughly clean the waste water tank when necessary and at least once a year.</p> </div>

Component	Maintenance	Notes and precautions
Pump	Replacement of impeller and mechanical seal	<p>This is a complex operation and should only be undertaken by skilled personnel.</p> <div style="border: 2px solid yellow; padding: 10px; text-align: center;">  <p>CAUTION</p> <p>The electric motor may be hot during operation. Pay attention. The electric pump must only be repaired by competent or qualified personnel, using manufacturer's spares; if this procedure is not followed, the manufacturer is relieved of any responsibility and warranty is void and null.</p> </div>

Component	Maintenance	Notes and precautions
Pump	Operation check and cleaning (at least every month)	<p>Electric pumps usually do not need ordinary maintenance, as long as some precautions are taken, which extend their lives (address to the pumps' Manufacturer).</p> <div style="border: 2px solid red; padding: 10px; text-align: center;">  <p>DANGER</p> <p>Before each intervention make sure that voltage is disconnected and that there is no possibility of accidental connection.</p> </div> <ul style="list-style-type: none"> • If there is a risk of freezing, it is necessary to empty the pump casing from the liquid and to fill it, before restarting the pump. • Make sure that the pump never runs dry. • The DC motor brushes must be periodically checked for consumption and spring pressure. • If the pump does not work for a long time, it is better to empty the pump casing and clean it. • If a filter and a foot valve are installed, check periodically for their efficiency and cleaning. • Check that the impeller is jammed, this could cause heavy damages to the electric motor; if this happens, descale the impeller and pump body. • At least once a month, have the operation of the grey/black water pumps checked, having their tanks filled with clean water until the pump activates and having the correct overboard draining checked.

5.2.2 WC operation

WC is ceramic with a vacuum system.

Proceed as follows to use the toilet:

- To pour water into the toilet before use, lift the flush lever until the water reaches the desired level. Usually, more water is only needed when solid excrement is to be rinsed out.
- To rinse the toilet, push the rinse lever firmly in the direction of the floor until the contents are sucked out of the bowl. At the start of flushing, it is normal to hear a dry, crackling sound in response to the opening of the mechanical seal. Make sure to keep the lever down for at least 3 seconds.
- Do not flush sanitary nappies or other non-disposable items down the toilet. Do not attempt to flush paper handkerchiefs, paper towels or excessive amounts of toilet paper.



CAUTION

Except for organic waste, only very thin WC paper can be discharged into the sea toilets. Paper tissues or handkerchiefs and sanitary napkins may clog and damage the WC-sanitary system.



CAUTION

Make sure that WC is electrically powered and that the black water system is operating before using them.



CAUTION

Forcing the WC discharge can cause overflow of the tank.

NOTE

For further information on use and maintenance, please refer to the manufacturer's manual.

5.3 SCUPPERS SYSTEM

The scupper system, by means of appropriate holes and drains, allows the quick off board flow of rain water, marine water or of other nature water, that may fall on main deck or on the sun-deck.

All waters collected by the scuppers are conveyed by means of manifold tubes, placed along the bulwarks.

The total or partial clogging of one or of more scuppers must absolutely be prevented, because it is a cause of flooding and consequent loss of stability by the yacht and its structures.

**CAUTION**

Always check the correct water flow towards the scuppers.
The partial or total clogging of one or more scuppers is a possible cause of damage for the yacht structure and of loss of stability.

**CAUTION**

Avoid that incorrectly stowed objects clog the scuppers.

Scuppers system diagram

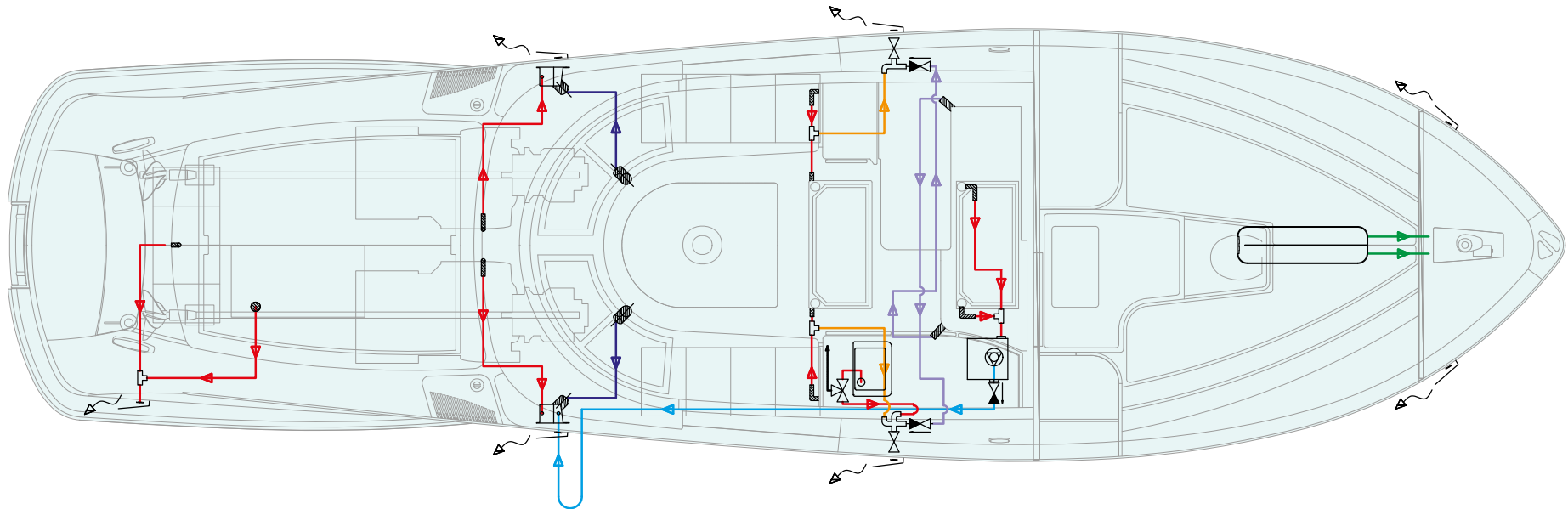

ICONA ICON	DESCRIZIONE DESCRIPTION
	Linea di scarico cassetta con pompa a immersione Discharge line with immersion pump
	Vasca bimini, scarico canalina giro prendisole, scarico vasca vano zattere, scarico lavello pozzetto Bimini compartment, sunbed area drain, liferaft compartment drain, cockpit sink drain
	Linea di giunzione tra scarichi canaline portello Junction line

ICONA ICON	DESCRIZIONE DESCRIPTION
	Linea scarico pozzetto timoneria Cockpit and wheelhouse drain line
	Linea scarico grandi masse pozzetto Cockpit drain line
	Linea di scarico canalina osteriggio di prua: Bow skylight discharge line
	Scarico a murata centralizzato Centralized discharge

ICONA ICON	DESCRIZIONE DESCRIPTION
	Pompa con vaschetta Rule drain
	Valvola di non ritorno One-way valve
	Valvola di non ritorno One-way valve
	Valvola a tre vie Three way valve
	Valvola a sfera Ball valve

5.4 BILGE SYSTEM

The centrifugal submersible bilge suction pumps, controlled by designated floats, pump the water from the bilge and send it overboard.

The bilge suction system consists of 3 submersible centrifugal electric pumps with a flow rate of 32 l/min each.

The pumps are located in the:

- Aft area of the engine compartment;
- Fore area of the engine compartment;
- Bilge under the cabin entrance.

The bilge pump inlets are equipped with a plastic mesh filter to prevent the entry of particles into the system which could damage the pump or clog the pipes.

The bilge pumps can operate both in automatic mode (via the float switches) and in manual mode.

Automatic pump activation is controlled by the float switch installed in the bilge near the pump itself.

The float activates the pumps when an excessive water level is detected.

The bilge pump in the fore area of the engine compartment is equipped with two floats located at different levels:

- The lower float controls pump activation in automatic mode;
- The upper float controls activation of the acoustic and visual alarms that signal high level of bilge water.

The activation of the bilge pumps and their respective high bilge water level alarms is available on side control panel on the port side of the helm position.

The pumps are connected directly to the batteries and can therefore always be activated, thus ensuring that water is expelled at all times.



WARNING

Keep the bilge dry to allow the prompt detection of water presence and to reduce the risk of slipping, besides creating a less aggressive environment for the fixtures.



CAUTION

In case of water presence in some compartments of the lower deck, before getting alert, check if the bilge water is fresh or salted, this will be of fundamental help with checking its source.



WARNING

Remove any rags or other residues from the bilge, to prevent any clogging of the pump intakes, causing serious damage to the pumps and impairing the safety of the yacht.



WARNING

The system total capacity is not designed for yacht draining in case of a hull leaks.







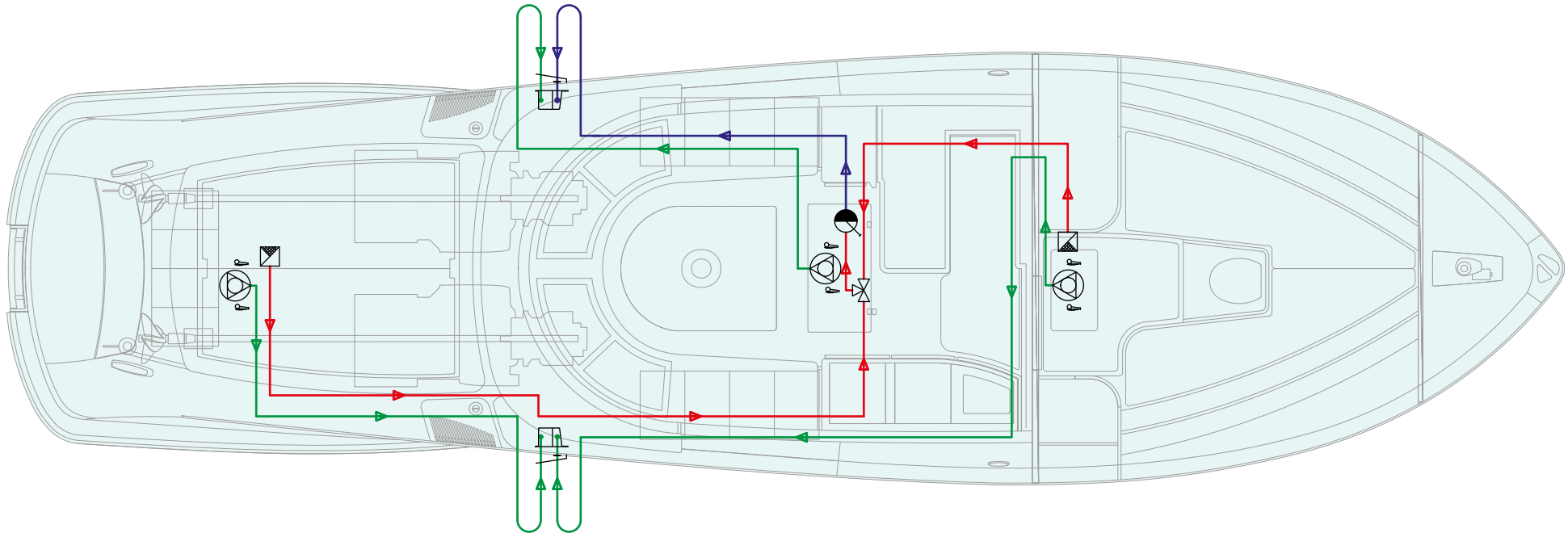

ENVIRONMENT



Possible oil or fuel spilled in the bilge must be collected and stowed.
It is forbidden to discharge bilge water mixed with oil or diesel fuel into the sea, because this can cause pollution.
Operation of the bilge pump must be prevented during maintenance in the engine compartment to avoid accidental spillage of liquids that may cause water pollution.

Bilge draining system diagram



ICONA ICON	DESCRIZIONE DESCRIPTION
	Linea di sentina Bilge line
	Linea di aspirazione di sentina Bilge suction line
	Linea di mandata di sentina Bilge supply line

ICONA ICON	DESCRIZIONE DESCRIPTION
	Scarico a murata centralizzato Centralized discharge
	Valvola di piede di non ritorno No return foot valve
	Elettropompa sentina Bilge electropump

ICONA ICON	DESCRIZIONE DESCRIPTION
	Pompa sentina manuale Manual bilge pump
	Galleggiante allarme / azionamento Bilge alarm / starting sensor
	Valvola a tre vie Three way valve

5.4.1 Maintenance of bilge automatic suction system

Component	Maintenance	Notes and precautions
Bilge pumps	Operation check Bilge pump operation check	As shown in the following sequence.
Non-return valves	Operation check	As shown in the following sequence.

Bilge pumps:

These pumps, normally, do not need ordinary maintenance, provided that some measures are taken which extend their operation.

- Make sure that the pump never runs dry.
- The brushes, on DC motors, must be checked at regular intervals.
- If the yacht must remain inoperative for a long period, it is advisable to drain the pump body and to clean it.
- If a filter and a foot valve are installed, check their efficiency and cleaning periodically.
- Check that the impeller is not jammed, this could cause serious damages to the electric motor; if this happens, descale the impeller and pump body.
- Periodically check the operation and protection of the various protective filters.

Bilge pump operation check

- Have the operation of each bilge pump checked, having the bilge filled with clean water up to the activation of each pump and having the correct draining overboard checked.
- Have the operation of each bilge pump checked also manually.

 **CAUTION**

Never run the electric pumps dry.

 **CAUTION**

Check the operation of all bilge pumps at regular intervals. Clean debris from pump inlets.

 **CAUTION**

Replacement of the pump and its components must be carried out by specialised personnel using only original spare parts.

5.5 SEAWATER SYSTEMS

The main engines are cooled by seawater, which is drawn directly by the internal centrifugal pumps of the engines.

The heat exchangers of the engines cool the fresh water of the internal cooling circuit by absorbing the heat.

Seawater enters through two outlets installed on the transom, the openings of which are fitted with a protective grille.

Many waters (port, river and coastal) contain sand and suspended substances. To prevent clogging of the heat exchanger and intercooler, and to increase the life of the engine cooling pump, each seawater inlet is equipped with an external water filter and a valve to be used during maintenance.

The cooling seawater drawn in by the engines is then sent to: the inverters to cool the lubricating oil; the gaskets for cooling and lubrication; the water injection system in the engine exhaust ducts.

Cooling water injected into the exhaust ducts is discharged overboard through the exhaust of the engine itself.



CAUTION

Before opening the seawater filter for cleaning, remember to close the valve.

When leaving the yacht unused, close all the check valves of the seawater outlets as a precaution; remember to reopen when reusing the yacht.



CAUTION

Before cleaning the seacock filters, check that any utilities supplied with seawater are switched off and not in use.

Sea water distribution system diagram

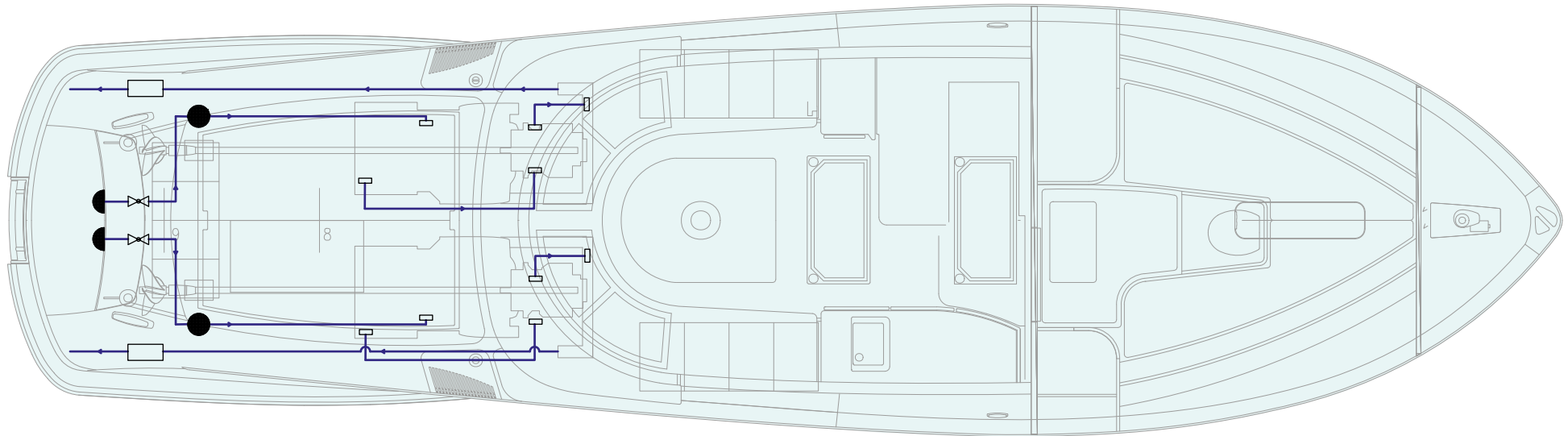

ICONA ICON	DESCRIZIONE DESCRIPTION
	Pres a acqua mare Seacock intake
	Seawater strainer Seawater strainer
	Silenziatore scarico gas Gas exhaust muffler

5.5.1 Maintenance of sea cocks and strainers

Component	Maintenance	Notes and precautions
Seacocks and strainers	Cleaning (as required depending on the docking area, but at least every month)	<p>This operation has to be carried out outside, therefore the yacht must be in a dry dock or you can ask the intervention of a diver.</p> <ul style="list-style-type: none"> • Have the sea cocks cleaned (removal of seaweed or barnacles. If necessary have them removed with a brush). <p>Inspection and cleaning valves and filters:</p> <ul style="list-style-type: none"> • Cleaning is to be carried out more frequently if the water drawn in is particularly dirty (seaweed, mucilage, etc..). <div style="border: 2px solid orange; padding: 10px; margin-top: 10px;"> <p style="text-align: center;"> WARNING</p> <p>Before removing the filter, it is necessary to close the valve fitted to the sea cock, to prevent flooding the bilge with water.</p> </div>

Component	Maintenance	Notes and precautions
Seacocks and strainers	Cleaning (as required depending on the docking area, but at least every month)	Inspection and cleaning valves and filters: <ul style="list-style-type: none"> • Check for barnacles or corrosion on the control levers of the cut-off valves of the filter to be checked. • Clean the control levers of the valves with a brush. • Move the levers repeatedly. • Close the cut-off valve upstream the strainer. • Remove the filter cover by loosening the screws. • Remove the filter element, clean it with a brush and rinse it in water (replace as necessary). • Clean the strainer housing. • Check and, if necessary, replace the gasket of the strainer cover. • Fill the strainer with water to avoid the pumps running dry or that the system does not prime. • Reposition the strainer, the cover and tighten the nuts. • Reopen the cut-OFF valve and check whether the strainer cover is leaking.



WARNING

Before servicing the sea water lines, disable the operation of the connected utilities.
 Before restarting the utilities, make sure that the cut-OFF valve is completely open.



WARNING

During navigation, periodically check the cleanliness of the seawater filters.
 If the yacht is crossing a dirty sea area, check the condition of the strainers and proceed with their cleaning.
 Taking suitable precautions is very important to prevent damage to mechanical parts (engines, etc.), discharge systems and to not jeopardize the safety of the yacht.



Riva

AQUARRIVA *special*

Riva

AQUARRIVA *special*

ELECTRIC SYSTEM

CHAPTER 6

6.1 ELECTRIC SYSTEM

The electric system of the yacht has been designed paying the utmost attention to all aspects regarding your SAFETY and the SAFETY of your Guests and it has been manufactured using high-quality materials, fully in compliance with the rules in force.

The electric system of your yacht consists of 3 defined and separated sections.

- Service system: powered by a nominal voltage of 12 V DC supplied by 1 12 V DC - 134 Ah accumulator battery. The above battery bank is recharged by the port engine alternator and the battery charger.
- Engine system: powered by a nominal voltage of 12 V DC supplied by 2 12 V DC - 134 Ah accumulator batteries connected in parallel for engines, thruster and windlass. This battery bank is recharged by the starboard engine alternator.
- 230 V utility system: powered by the shore system.

The 230 V a.c. section is powered by a 20 A shore power supply with suitably sized power cable, protected on the yacht by a 16 A main switch associated with a differential switch.

The yacht is equipped with electronic injection machines and electronic remote control systems. For this reason it is very important for the user to carry out some simple operation to prevent faults to the electric systems, which on their turn may cause problems to the propulsion system.



CAUTION

Before undertaking any navigation, check that the batteries are in good condition and that they supply the correct nominal current.



CAUTION

During navigation, the service battery and engine batteries must always be kept connected. The parallel switch on the two banks must normally be disconnected and then turned OFF.



CAUTION

If there is a malfunction of the charging alternator during navigation, turn the parallel switch between the battery banks to ON and leave it on for the shortest possible time.



CAUTION

Do not embark on navigation unless the engine battery switch and that of the service battery switch are both engaged and do not disengage during navigation.



CAUTION

If there is a significant and persistent drop in the voltage of one or both battery banks during navigation, check the charging efficiency of the relevant alternator.

**CAUTION**

The engine control systems: accelerator and gears engagement remote controls are electronic. Their reliability is very high, but in case of a sudden black-out, it is necessary to immediately switch OFF the engine which is not controllable any more by means of the relevant buttons located in the helm position.

**CAUTION**

Disconnect the dock power supply connections when the system is not in use.

**CAUTION**

Use electric devices with double isolation or grounding.

**CAUTION**

When the engines are switched ON, the engine and service charger is automatically switched OFF to prevent them from working in parallel with the engine charging alternator.

**WARNING**

Do not allow the end of the shore power cord to float in the water. This may create an electric field that can cause injury or death to swimmers in the vicinity.

**CAUTION**

Do not modify the shore power cable connectors; use only compatible connectors.

The on board electrical system has been designed and installed in compliance with UNI EN ISO and RINA standards, applying the following criteria:

- All wiring, joints and line-feed protection devices such as magneto thermal breakers, RCCBs and fuses have been collected and grouped both within and on the front plates of the various on board electrical panels.
- All power lines are oversized, ducted and/or inspectable and made with flame-retardant cables laid inside special self-extinguishing sheaths; all the aforementioned lines are connected with special spring-loaded terminal blocks.
- The system is highly fragmented into sub-circuits and protected with magneto thermal breakers and fuses for each single load or homogeneous load groups in order to simplify the tracing of possible faults which, for any line, can only occur at the load and the electrical panel.

The protection of the single electric system sections is performed by automatic magneto-thermal breakers of different amperage and size, according to the absorption of the various services to be protected and by the size of cables used for their supply.

All metallic wet pieces are interlocked with equipotential connections and linked on sacrificial anodes installed on the underwater quick-work.



WARNING

Refrain from performing any modification or intervention on the system and on the panel and take advantage of experienced Companies and skilled staff. Avoid any derivations on the power lines and the addition of utilities not provided on the panel itself. If you need to assign services to the switches available, make sure that their characteristics are suitable with the device installed.



WARNING

NEVER:

- Work on the electric system while under voltage.
- Modify the electric systems of the system or relevant drawings: the installation, the modifications and the maintenance must be carried out only by a skilled marine electrician.
- Alter or modify the intensity of rated current of protections against overcurrent.
- Install or replace electric equipment or devices with components exceeding the rated current intensity of the circuit.
- Leave the yacht unattended with the electrical system powered, except for the circuits of the bilge automatic suction pumps, of the fire-fighting protection and of the alarms (directed to battery).



DANGER

Electrocution hazard! Turn the power OFF before removing the cover and servicing any electrical equipment internal component.



DANGER

All electrical systems (included those at low voltage) if wrongly handled or subjected to overloads, can originate short-circuits and dangerous overheating with potential fire hazards!



CAUTION

If you are compelled to use the “battery parallel connection”, turn OFF all electronic devices, so as not to jeopardize their correct operation. In emergency conditions, use the battery parallel set for the shortest reasonable time.



DANGER

We recommend, in order to operate in complete safety, to carefully read the safety rules relevant to the maintenance and contained in this manual.



DANGER

Before working on the charger, disconnect the shore power supply.

**CAUTION**

RIVA suggest to examine very carefully the whole documentation delivered by the manufacturers of the various components; and for any problem relevant to maintenance, to contact RIVA After Sales & Service Department directly.

**DANGER**

The system is similar to a domestic system in terms of features and risks and, if “wrongly” used, mishandled or serviced, it statistically represents one of the most frequent reasons for fire on board.

**DANGER**

Have the internal status of the charger checked by specialised personnel at least once. Faults like loose connections, burnt wires, etc., with following risk of fire spreading, must be repaired immediately.

**WARNING**

Do not disconnect the battery master buttons with engines running or you may damage the engine alternators.

**CAUTION**

For the correct procedures of fuses replacement refer to the on-board electric manual delivered separately.

The on-board services are supplied by separate electric systems with different features:

- 12 V DC;
- 230 V AC (50 Hz).

6.1.1 Maintenance of the electric system

Component	Maintenance	Notes and precautions
Equipment and circuits	Cleaning and check	At least once every six months, have the various connections of electric boards, panels and boxes checked by experienced personnel. Make sure that ground connections of electric equipment and electrical panels are tight and not oxidized. Have the absorption of the different electric motors periodically checked by skilled personnel. Check the status of the protection anodes and replace if necessary.

MAINTENANCE

At least once a week check the operation of all electrical panels.
At least once every six months:

- Check the possible presence of damaged cables;
- Protect the various contacts.



CAUTION

It is forbidden to use pressurized water on light appliances installed outside.



DANGER

Do not modify the electric systems or relevant drawings. The installation, the modifications or the maintenance must be carried out only by a skilled naval electrician. Inspect the system at least once a year.



DANGER

Before carrying out any work on the electrical system, disconnect all circuits.

6.2 ELECTRICAL PANELS



CAUTION

Before removing the front panel for maintenance, disconnect the shore connection.

NOTE

For a detailed description refer to the electric installation manual.

MAIN ELECTRICAL PANEL

The electrical system is controlled from the panel located on the cabin access stairs.

The following main sections have been identified, in order to make the descriptions easier:

1. Battery measurement instrument, waste water system management and shore line connection light.
2. Circuit breakers for 12V uses powered by engine batteries.
3. Circuit breakers for 12V uses powered by service batteries.



CAUTION

Always keep the safety systems powered.
Operate the battery disconnect switch for safety systems only in the event of a short circuit or an emergency.

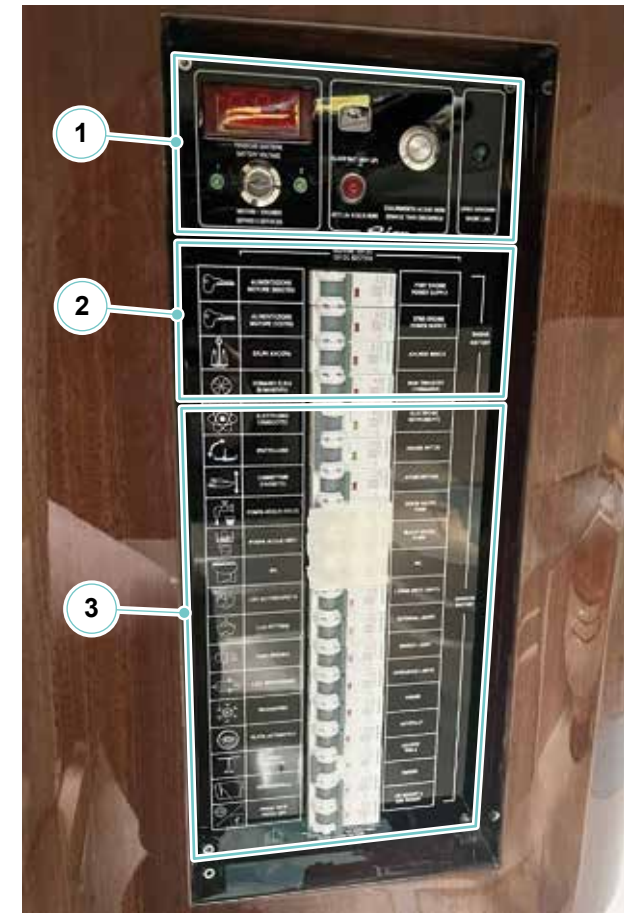

1. Battery measurement instrument, waste water system management and shore line connection light.



2. Circuit breakers for 12V uses powered by engine batteries.



3. Circuit breakers for 12V uses powered by service batteries.

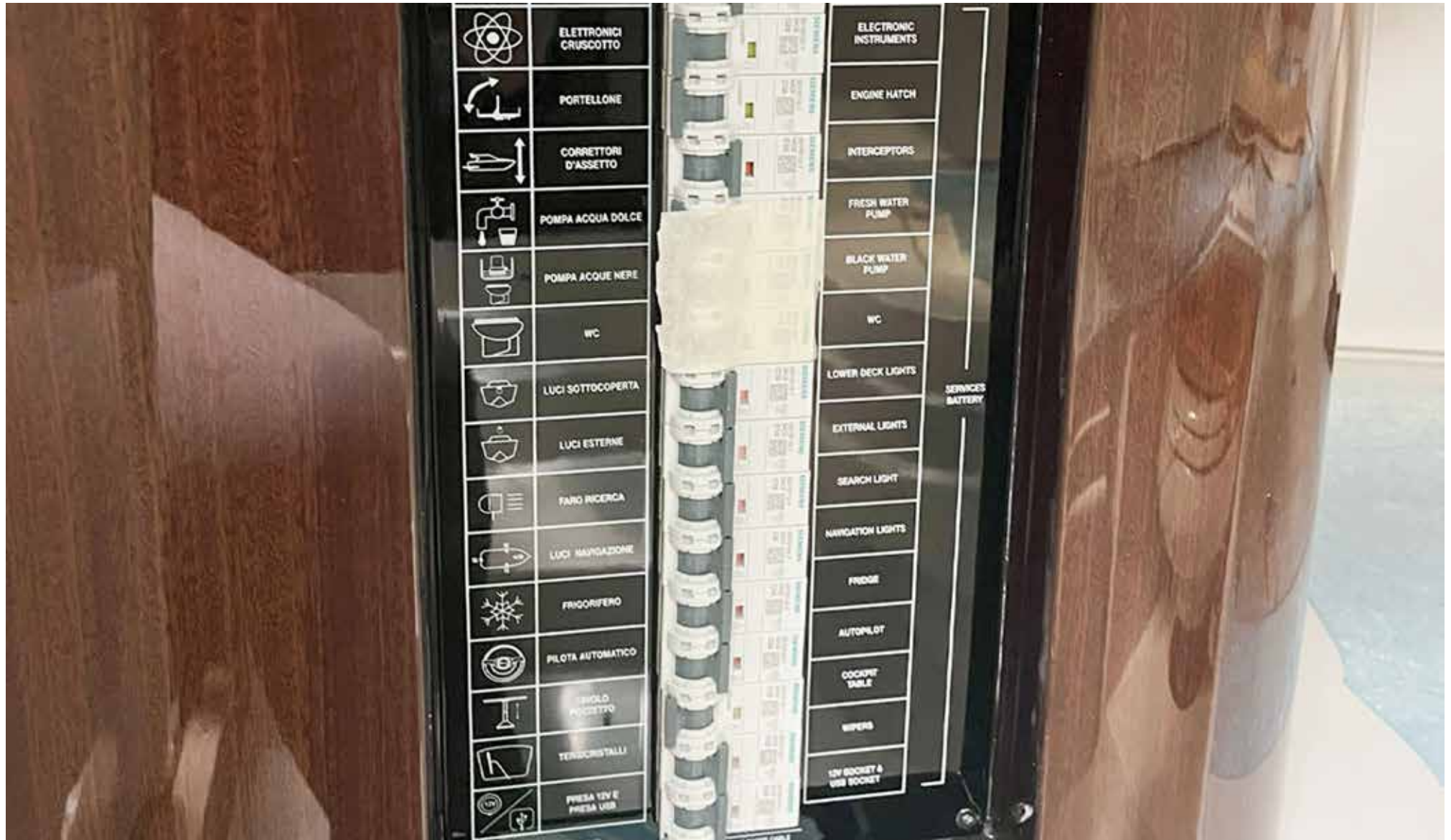

6.3 BATTERY SET

Batteries are normally charged by the alternator during engine operation. Alternatively, they can be recharged with the charger powered by the shore power supply:

Description	Element number	Features element
Engine batteries	2	12 V 134 Ah AGM
Service battery	1	12 V 134 Ah AGM
Gyroscopic stabilizer battery (opt)	1	12 V 134 Ah AGM

SERVICE BATTERY:

There is 1 12V 134 Ah battery. The various devices (batteries and chargers) are connected to each other in the system and all battery status data (voltage, charge/discharge, residual capacity, etc..) are available on the main electrical panel. The port side engine alternator guarantees the charge under the service battery bank during navigation.

It is good practice when using the yacht in port to always keep the charger on to prevent discharge of the service batteries, which might disconnect the safety systems. Monitor the battery parameters.

Similarly, during navigation it is good practice to use the port engine alternator to recharge the service batteries while keeping the charger off. The ideal charge status of batteries for storage is about 60%. Check the voltage of the batteries at least every 3 months, recharging them if necessary.

ENGINE BATTERIES:

The engine batteries consist of 2 batteries connected in parallel to form one 12V 134 Ah bank.

On board, the charger supplied is also used to recharge the engine batteries. During navigation, the port engine alternator recharges the engine batteries.

The services and engine battery breakers are controlled from the battery breaker panel located in the cockpit.



WARNING

The batteries left unloaded over long periods of not operation, lose progressively their charge, until they become completely flat and get irreparably damaged.



DANGER

NEVER obstruct the air intakes of the battery boxes, as natural ventilation must always be allowed for the batteries so that they do not overheat.



WARNING

Do not lay objects on the cases containing the batteries.

**CAUTION**

A frozen battery may blow up if used or charged; do not start a Yacht with frozen battery. To prevent the battery from freezing keep it always completely charged.

**DANGER**

The battery releases explosive gas: do not approach sparkles or a flame nor smoke near it. If the battery is used or charged in a closed area, check for good ventilation. Do not check the battery charge by short-circuiting the terminals with metal tools: use a density gauge or a voltmeter.

**WARNING****EXPLOSION HAZARD**

Any lithium battery powered device on board must be recharged only in open air areas, connected to a suitable charging system. Also please refer to the device dedicated Use and Maintenance Manual.

NOTE

For further information on use and maintenance, please refer to the manufacturer's manual.

6.3.1 Checking and maintaining batteries

Component	Maintenance	Notes and precautions
Batteries	Battery check (accumulators)	The batteries installed are low maintenance batteries, with no special control needs: It is recommended, however, to check the status at least twice a year and whenever there is a difficulty or delaying of charging time.



CAUTION

In case of contact with battery acid, wash the contaminated part with fresh water for at least 15 minutes and consult a doctor.



CAUTION

Monitor the voltage of the engine and service batteries. During the charging phase 29.1V can be reached, this is a temporary value, well tolerated, both by the batteries and by the battery charger. This value must be monitored and, if this situation lasts for too long, the magneto-thermal breakers of the battery charger must be disconnected.



CAUTION

Remove bracelets, rings and every other piece of jewellery before working on the batteries.



CAUTION

Always keep the batteries charged and recharge them periodically even if the yacht is left unattended. If the charge level drops to the minimum, the batteries can get irreparably damaged. Check the charge status each week.



WARNING

All maintenance operations listed must be performed only by skilled personnel.



CAUTION

Stop the engine before inspecting or servicing the battery.
 Disconnect the battery cables before working on the electrical system to avoid arcing or damage to the alternator.
 Disconnect the negative (-) cable first, then the positive (+) cable.



WARNING

The battery replacement must always use the original model of battery originally furnished by the shipyard.

Carry out following checks:

- Check that the battery containers are clean and dry and that the terminals are coated with silicon grease and properly fastened. Clean and grease as required. Inspect at least every 6 months.
- Identify positive and negative cables, prior to connecting (connect the positive terminal first and then the negative, in order to avoid sparkles).



DANGER

Batteries may be subject to explosion hazard, with subsequent risks of serious personal injuries. Do not use open flames, smoke, cause sparks or use arc-welders in the area where batteries are located. Do not disconnect battery cables when the generator is running.

Battery acid may cause serious injuries. Wear safety goggles, gloves and protective clothing.

Do not wear any bracelet, ring or any other jewel when operating on batteries.

In case of contact with battery acid, wash the contaminated part with fresh water for at least 15 minutes and address to a doctor.



DANGER

Always remove the negative terminal (-) for earth connection first and connect it last.



DANGER

Operations on batteries must be performed by qualified personnel.



CAUTION

Check the condition of the batteries, making sure there are no traces of electrolytic corrosion on the poles and connection terminals; if corrosion is detected, contact servicing and replace the affected elements.

6.4 BATTERY BREAKER

The main battery disconnect panel is located under the captain's seat. The battery breaker panel contains the remote controls with the following functions:

- Service battery breaker (1). Engages or disengages the service battery group.
- Engine battery breaker (2). Engages or disengages the engine battery group.
- The parallel control of the service/engines batteries is located in the side control panel on the helm position.
- Parallel between service and engine batteries. If the engine batteries are low or not sufficiently charged to allow the propulsion engines to start, the battery parallel button allows the engine battery group to be put in parallel with the service battery group, thereby starting the propulsion engines.
- Thruster battery breaker (3).
- Direct services battery breaker panel (6). This battery breaker is located in the engine compartment.

In the engine compartment there are the manual engine (4) and service (5) battery breakers.



CAUTION

This should only be used if the engine batteries are not sufficiently charged. The parallel battery selector must only be operated with the battery bank connection selectors ON.

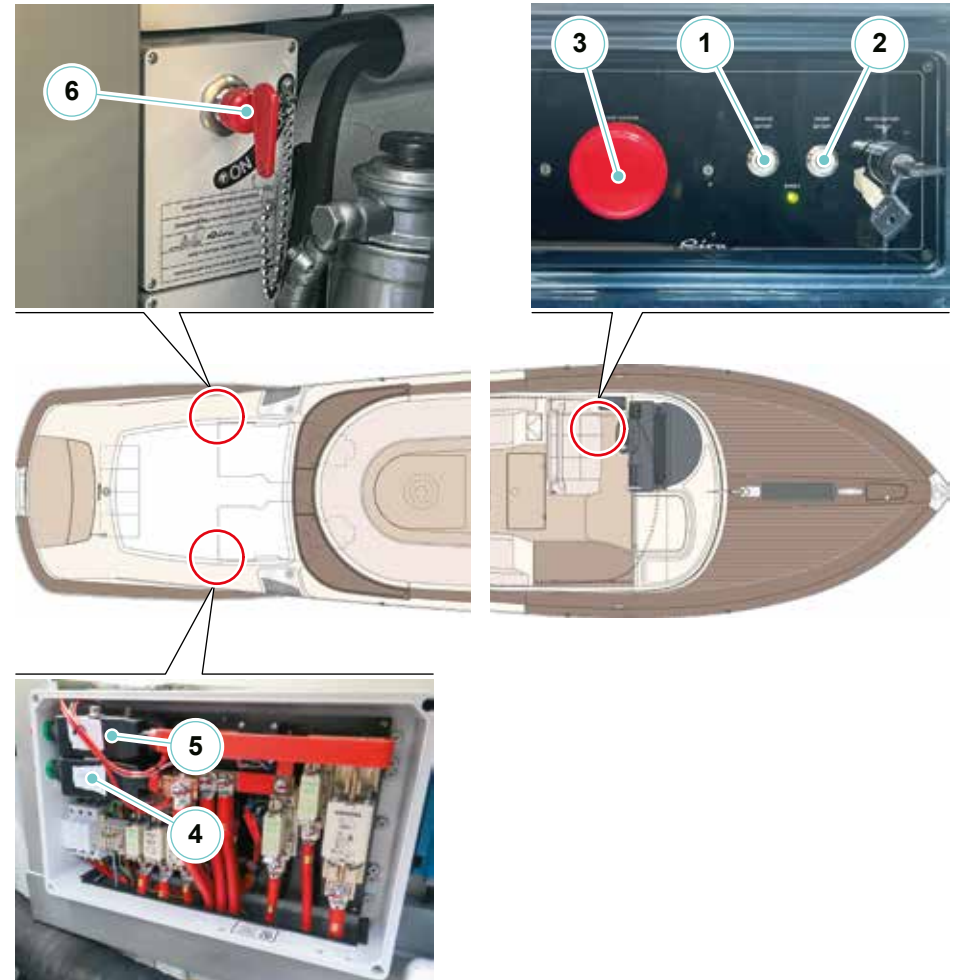



CAUTION

Never disengage the battery breakers with the engine running as this may damage the engine alternators.



CAUTION

The “battery parallel” button must be used only in case of real need and must be switched OFF as soon as possible.

The general fuse for the manoeuvring thruster circuit is physically located on the housing of the dedicated battery breaker.



DANGER

Always keep the safety system battery breaker in the ON position. Disconnect only in the event of a short circuit.

6.5 BATTERY CHARGER

On board your yacht there is a fully automatic and high-performing battery charger. The battery charger uses an optimized charging technique to rapidly and safely charge the batteries, while also supplying the connected uses. The charger is protected from short-circuits, overcharges and high temperatures (engine compartment).

On front of the battery charger, there's the monitoring panel which allows to control the operation of the battery charger and monitor the charging process.

The charge bar display shows the percentage of maximum current of the battery systems.

The symbol (V) in combination with charging bar shows the actual load voltage.

Power LED green	Yellow LED (Setting mode)	Power LED blinking red
Current 100%	Connected to Master-Bus (read only)	Temperature error
Current 75%	MLi	Charger failure
Current 50%	2-step	Wrong AC voltage
Current 25%	Wet battery	Battery voltage too high
Current 5%	GEL/AGM battery	Battery voltage low, short circuit. Charger output reduced to 25% of its maximum.

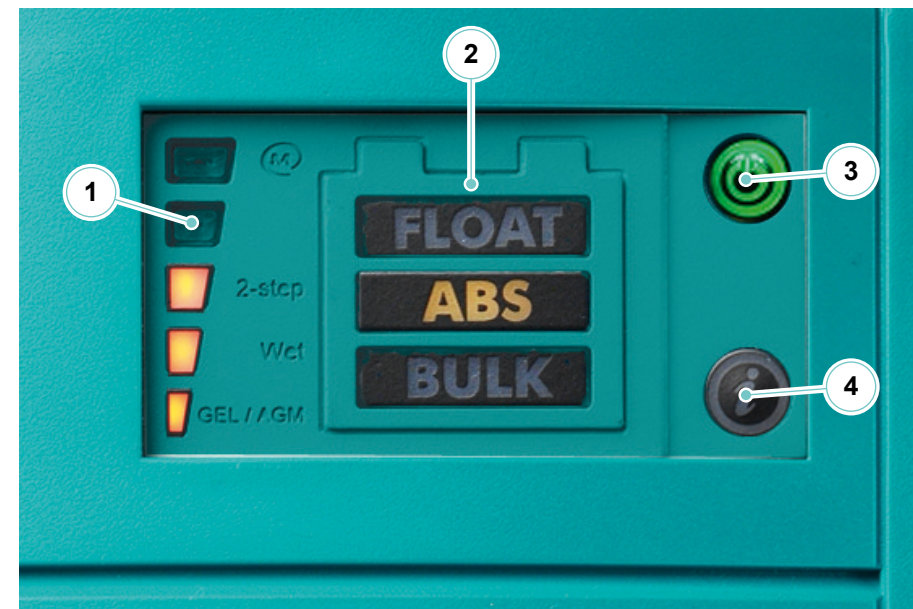

1. Load bar.
2. Current status of the 3-stage loading method: Bulk, Absorption e Float.
3. Power LED.
Green = ON,
Red = standby.
4. SET button.

NOTE

For further information on use and maintenance, please refer to the manufacturer's manual.

6.5.1 Battery charger maintenance

Component	Maintenance	Notes and precautions
Battery charger	Inspection charge output	<p>At least two or three times a year, have a specialist check the connection of each cable for looseness and oxidation.</p> <p>Keep the battery charger dry, clean and away from dust in order to ensure a good dissipation of heat.</p> <p>Periodically check the good condition of the cooling fan.</p>



DANGER

Do not work on the battery charger or on the electric system if they are still connected to a current supply. Disconnect the mains supply before connecting or disconnecting the battery. Modification to the electric system must be carried out exclusively by skilled personnel and only after the approval of RIVA.



CAUTION

Disconnect the shore power supply connections when the system is not in use.



CAUTION

The connection between the mains and the charger is not interrupted with the switch.



DANGER

Have the inner condition of the battery charger checked by skilled staff at least once a year. Faults like loose connections, burnt wires, etc., with following risk of fire spreading, must be repaired immediately.



CAUTION

If the engines are running, the alternators are obviously charging the batteries, so it is advisable to keep the battery charger magneto-thermal on OFF to avoid damaging the alternators.



CAUTION

Should the battery voltage drop under 18V, the battery charger will supply a current corresponding to the 25% of the maximum one and the recharge time will consequently increase.

NOTE

For further information on use and maintenance, please refer to the manufacturer's manual.

6.6 ELECTRIC SHORE POWER SUPPLY



DANGER

Before connecting the dock socket, ensure the type of voltage and the sockets available, their integrity and the absolute absence of moisture on the wire, on the socket and on the plug.

With plug connected check that wire:

- Cannot get in traction as a result of tide variations, yacht movements, etc.;
- Cannot get crushed, etc.;
- Does not come into contact with water.



CAUTION

The connection must be performed under safety conditions with not powered connections and by paying attention to carry out a correct grounding.

The shore columns can supply different types of voltage, according to the harbour where you are moored; contact the Port Authority for the correct power supply of the column you are going to be connected.

In order to power the yacht's electrical system, which in turn ensures operation of the various on board systems, a 20 A 230 V shoreside connector (1) have been fitted astern.

It occurs very often to find dock plugs with dimensions not compatible with those on the yacht; in this case it is necessary to contact the Port Authority and to get a new plug or an adapter.

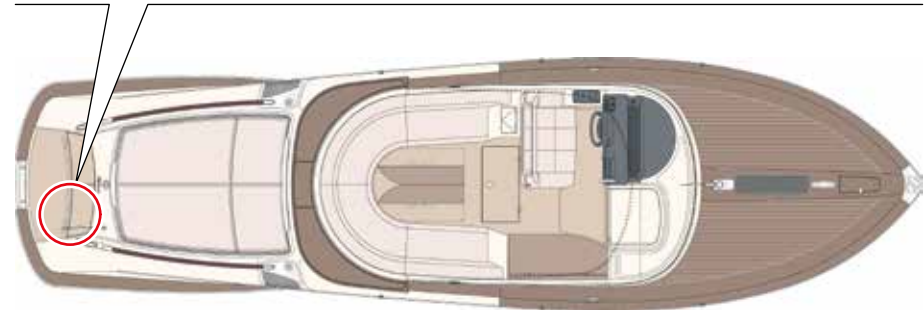

Shoreside electricity supply connection procedure:

- On the shore connection electrical panel in the engine compartment, open (OFF) the general circuit breakers for on-board services;
- Turn off the power on the shoreside charging point;
- Connect the power cable, first to the yacht and then to the shoreside charging point;
- Turn on the power on the shoreside charging point;
- On the shore connection electrical panel in the engine compartment, close (ON) the general circuit breakers for on-board services.



CAUTION

Do not modify connectors of dock power supply cable, use only plug compatible connectors. If the yacht power supply cable cannot be plugged into the dock socket, ask the Port Authority for an adapter. In any case, never use adapters cutting the mass conductor connection between the dock electrical system and the yacht electric system. The use of these adapters can irreparably damage the electric devices.



DANGER

Do not leave dock power supply connected if nobody is on board.



DANGER

Before carrying out any intervention on the electric system, disconnect all circuits and the dock plug.



WARNING

If the indicator light on the main electrical panel is on, it means that the shore connection is inserted into the plug.



CAUTION

Disconnect the dock power supply connections when the system is not in use.



DANGER

Do not allow the end of the shore power cord to float in the water. This can cause an electric field as well as injuries or even the death of the swimmers nearby.



CAUTION

To stop the shore power supply, follow the steps for connection in reverse order.



DANGER

Risk of electric shock from leakage currents. Never swim in waters near harbours or marinas.

6.7 FUSES

In addition to these protections, there are common fuses with types and characteristics appropriate to the specific installation.

Please refer to the electric system user's manual for their location on board.

The main fuses on board have the following characteristics:

- 1 A
- 2 A
- 3 A
- 5 A
- 6 A
- 6,3 A
- 10 A
- 32 A
- 100 A
- 125 A



DANGER

For reasons of safety and reliability of any electrical system, any fuse must be replaced with one which has the same electrical characteristics: in case of doubt, consult an expert technician.



DANGER

At the end of eventual replacement of a fuse, ensure the proper keeping: **DO NOT** not leave any foreign objects inside the panel.

NOTE

For further information on use and maintenance, please refer to the manufacturer's manual.

6.8 SACRIFICIAL ANODES

The submerged metallic parts of the yacht are protected against galvanic corrosions by means of anodes. Check for their wear very frequently, as it depends also (and highly) on environmental factors like sea chains nearby, metal posts or docks, metal hulls moored nearby, electric devices, etc..

The replacement is necessary when the wear exceeds 50%.



CAUTION

Each time the yacht is lifted, check for the condition of the propeller, of the protection anodes and of the fastening system.

Replace the anode frequently.

6.8.1 Checking and maintenance of sacrificial anodes

Component	Maintenance	Notes and precautions
Sacrificial anodes	Periodical check (as necessary, according to the floating area) Assembly/disassembly	Metallic parts are protected against galvanic corrosion (caused by electrolytic currents due to the approach of different metallic bodies as steel or aluminium) by means of sacrificial anodes fitted on bottom hull, on stabilizer, on propeller shaft, etc.. The anodes' wear may depend on environmental factors as nearby chains, hulls or metallic docks, bad insulation of ground electric systems.

Periodical check

This operation must be carried out with yacht on dry dock or with the help of a diver.

Have the outer condition of the sacrificial anodes checked and have them replaced if they show evident signs of corrosion or if their volume is reduced to about 50%.

With the yacht out of the water, it is good practice to use a wire brush, to remove the surface layer of oxide and dirt on the external surface of the anodes.



CAUTION
Failure to replace anodes will lead to corrosion on other metal parts.

Assembly/Disassembly

The sacrificial anodes are fastened to the yacht in several positions of the hull. We advise you to clean the seat of the sacrificial anode and cover with silicon the screws ends which fasten the anodes. This will ease the replacement of the anodes when worn out. We advise not to tighten the nuts fastening the anodes with glues or other materials which will hinder their removal.



CAUTION
Do not cover the contact surface between anode and hull with silicone.



CAUTION
Do not use pressurised water to clean the sacrificial anodes.



WARNING
For cleaning or inspection with the yacht in the water, disable engine start-up.

Riva

AQUARRIVA *special*

PROPULSION SYSTEMS

CHAPTER 7

7.1 MAIN PROPULSION SYSTEM

All the components for yacht propulsion are assembled within the engine compartment,

The propulsion system consists of two equal units.

Each one includes:

- Engine YANMAR 8LV-370;
- Flexible engine supports;
- Gearbox “ZF90IVTS”;
- Coupling handle;
- Mechanical seal;
- Propeller shaft;
- Propeller shaft support;
- Propeller;
- Rudder.

ENGINES:

Technical specifications	
Model	8LV-370
Brand	YANMAR
No. of cylinders	8
Configuration	90° at V
Effective output	272 / 370 kW/mhp
Rated speed	3800 rpm
Dry weight	435 kg

For any information related to troubleshooting or engine maintenance, please refer to the supplementary manuals or the manufacturer’s service centres directly.

NOTE

For further information on use and maintenance, please refer to the manufacturer’s manual.



CAUTION

Do not operate the craft with an engine of rated power exceeding the maximum recommended power (actual power engine series).

Among all the possible interventions to carry out on the engines in case of need (see the operating instruction manual) hereunder are the most useful, according to our experience:

- Replacement of the fuel filters.
- Replacement of the oil filters.



CAUTION

The engine data boards are very important in case of repairs. Therefore keep them with care together with the warranty.

Remember that you can obtain a flawless operation and a high power only by respecting the prescribed maintenance intervals and by using the specified fuels and lubricants.

The engines have been installed on suitable elastic struts, which absorb vibrations and allow the minimal motion of the engines; in this way structures and devices connected with them are not damaged.

Besides, the elastic struts allow easy engine position adjustment, both for a new installation or after the required run in.

7.1.1 Engine control panel

These panels are located in the cabin inside the port side cabinet. This station must be used only in case of emergency. The controls on the panel allow all procedures for yacht navigation to be executed in "Local" mode.

The engine can be started or stopped via the panel.

NOTE

For further information on use and maintenance, please refer to the manufacturer's manual.

7.1.2 Start of propulsion engines

Commissioning

Before starting a new or overhauled engine, carefully read the relevant Manufacturer's Documentation. During the first service hours it is advisable to have new engines run below 75% of their maximum load and at variable speeds. After this initial run-in, the engine should be brought up to full output gradually.



CAUTION

Use only approved technical fluids; otherwise the Manufacturer's warranty will become null and void and the engines can get seriously damaged.

Daily start-up

Before daily starting of the engine, check fuel level, coolant level and engine oil level and replenish, if necessary. In case of need, fill with fuel, coolant and oil mix.



CAUTION

Engines must always be started with gear boxes at idle run and throttle levers must be set at minimum speed.



DANGER

Before starting the engines, make sure that nobody stays within the dangerous area of the engine compartment.

Cooling liquid

Fill the chilling system of the engine with a mixture of drink water and anti-freeze or anti-corrosion agent.

- Pour in coolant slowly in the expansion tank through proper filler.
- For the quantity of coolant, see the relevant manufacturer's documentation.

Engine oil



CAUTION

Do not top up oil so to exceed the MAX notch of the dipstick. If the oil level is too high, damage to the engines may occur!

Pour lubricating oil into engine by means of proper filler neck. For refuelling quantities, refer to the Manufacturer's manual.

Sea water suction pumps



CAUTION

Do not let raw water pump run dry!
Make sure that all valves of the raw water circuit are open.
Drain the pump in case of freezing danger.

Oil level check

Check engine oil level only approx. 20 minutes after the yacht has been switched off.

- Pull out dipstick for oil level check.
- Wipe it with a clean, dry and lint-free cloth.
- Place it back up to retainer.
- Pull out dipstick again.

The oil level should be between the two notches in the dipstick and must never fall below the MIN notch. Top up oil as necessary.

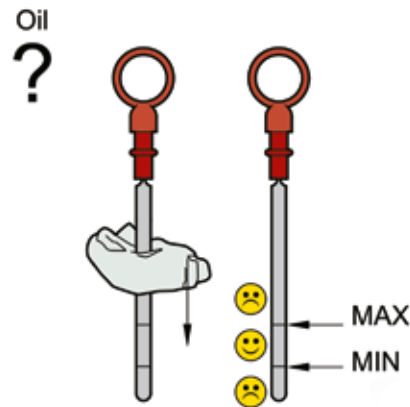

Ensure utmost cleanliness when handling fuels, lubricants and coolants.



CAUTION

Do not top up oil exceeding the MAX notch of the dipstick. If the oil level is too high, damage to the engines may occur!

Waste oil drain

It is possible to drain the used oil from the propulsion engines by using a manual pump activated by means of the relevant lever.

Engage and check the correct operation of the following utilities:

- Electronic engine starter key;
- Engine compartment air extractors;
- Navigation lights;

NOTE

The electronic engines start system does not involve actually inserting the keys into the key slot, but simply swiping the key (E-key) on the engines ignition.

Procedures for start-up

Perform the following operations for each engine.

- Put the inverter in neutral using the engines control lever installed on the helm position.
- Activate the “Port engine power supply” and “Stbd engine power supply” magneto-thermals on the main electrical panel.
- Hold the E-Key in front of the panel, the system unlocks and IGNITION switches ON.
- Press the port engine electronics activation button on the engine control panel.
- Press and hold the “Start/Stop” button to operate the starter engine.
- Do not operate the starter engine for more than 10 consecutive seconds; if the engine has not yet started, release the button, wait about 30 seconds and then operate the starter engine again.
- Only after starting the first engine and checking that it is working properly should you start the second engine following the same procedure.
- After starting the engines, check that the oil pressure rises to normal values within ten seconds. If oil pressure remains low, stop the engines immediately.

**CAUTION**

If you have to connect the batteries in parallel for the start-up of the propulsion engines, it is suggested to disconnect the electric devices in order to avoid current rushes or drops.

**CAUTION**

Should a magneto-thermal switch trip, do not try repeatedly to reset it, but check the relevant electric system condition.

**CAUTION**

We suggest avoiding slow running for more than 5 minutes. The slow run implies major wear of the engine mechanical parts and is the most harmful from the point of view of polluting exhaust.

NOTE

For further information on use and maintenance, please refer to the manufacturer's manual.

7.1.3 Checks after start of propulsion engines

Following correct engine startup, some checks must be performed:

- Check that water is being ejected from the semi-submerged exhaust; if this does not happen, accelerate slightly with the engine in neutral for a few seconds. If there is still no trace of water ejection, stop the engines, identify the fault or call for assistance.
- Check for strange noises or excessive smoke. If these are detected, stop the engines and call for assistance.
- Check that alternators load the batteries.
- Verify the efficiency of the instrument system.
- Plug out the dock cable if connected.
- Remove moorings and check for loose mooring ropes or floating objects hindering the propellers' movement.

**DANGER**

Make sure that no crew stands in front of gas exhausts and near the mooring ropes.

7.1.4 Stop of propulsion engines

Do not immediately stop the engines after a full-load operation, but let them run low (for approx. 5 minutes) to balance the temperature differences.

The operations to be carried out to stop the engines are as follows:

- Put the inverter in neutral using the engines control lever installed on the helm position.
- Press and hold the “Start/Stop” buttons on the helm position.
- Press the  buttons to deactivate the engines electronic;
- Disconnect the circuit breakers on the engine control panel.



CAUTION

With engines stopped carry out following:

- Disconnect all unnecessary electric utilities and check the general status of the switchboard as well as the voltmeters and ammeters indications;
- Check the switches of the bilge pumps and their regular operation;
- Check for possible leaks from the shaft lines seals;
- Rinse the yacht with fresh water;
- Connect dock electric power supply;
- Leave the engine compartment air extractor running until it stops automatically.



DANGER

Make sure that the engines cannot be started by unauthorized staff.

7.1.5 Emergency stop of propulsion engines

In the event of a mechanical or electrical fault, the normal and efficient engine shutdown procedures may not be effective; it may therefore be necessary to shut down the engines according to the EMERGENCY procedures.

- **Emergency STOP buttons on the helm position:**
On the helm position are the buttons “EMERG. STOP”; keep them pressed until the engines have shut down.
- **Emergency STOP buttons in the cabin:**
If it is not possible to shut down the engines using the buttons on the helm position, press the emergency button in cabin on the engine control panels.



CAUTION

An emergency stop puts the engine under considerable stress, with a consequent risk of damage to its components. Only use an emergency stop in genuine emergency situations.



DANGER

Before restarting the engines following an emergency stop, ensure that the cause of the fault has been identified and rectified.



CAUTION

The engines emergency stop controls must be used only in case of real emergency. Never use these controls during the normal engine stop procedure.

7.1.6 Engine maintenance

Component	Maintenance	Notes and precautions
Lubrication system	Replacement of the oil separator filter	Replace the separator filter, according to the time intervals suggested by the Manufacturer.
	Oil level check	Check the oil level by means of the special dipstick; make sure the level is included in the allowable range (MIN - MAX). Do not start the engines if the oil level is not included between the two reference marks, as indicated in the Manufacturer's Manual.
	Oil and oil filter replacement	Replace engine oil according to time intervals and oil type suggested by the Manufacturer.
Fuel system	Fuel filter replacement	Replace fuel filter within the intervals indicated by the Manufacturer.
	Fuel filter condensate drain	After each engine oil change, open the drain plugs and allow the condensate to drain away until only fuel flows out.
	Air cleaner replacement	Replace air filter within the intervals indicated by the Manufacturer.
Cooling system	Coolant check	Make sure the coolant is in the tank (lever sensor, reference plate, built-in eyelet).
	Chilling system filling	For coolant features refer to the User's Manual of the Manufacturer.
	Chilling system drainage	Drain the coolant only when the engine is stopped; follow the procedure indicated by the Manufacturer.

**DANGER**

A wrong use, a wrong maintenance, tampering and replacement of pieces, can cause serious damages or lethal events, beyond damaging the equipment.

The interventions on the electrical and mechanical equipment must be carried out by qualified staff after having examined the Manual delivered by the Manufacturer.

**ENVIRONMENT**

Dispose of waste materials (engine oil, fuel, filters, etc..) with respect for the environment and according to the laws in force. Use only authorized disposal procedures, in case of doubts, contact the Port Authority.

**DANGER**

Any maintenance procedure on the engines is to be carried out with engines shut off, after they have sufficiently cooled down and after seeing to the prevention of their being switched on by disconnection of the magneto-thermal switches.

**CAUTION**

Use only approved fuels, otherwise the Manufacturer's warranty will become null and void.

**CAUTION**

Do not top up oil exceeding the MAX notch of the dipstick. If the oil level is too high, damage to the engines may occur!

**DANGER**

Do not use open flames, do not generate electric sparks. Do not smoke. Avoid ignition sources. Risk of fires and explosions!

**DANGER**

Compressed air at high pressure may create the risk of injuries. Do not direct compressed-air jets at persons. Wear protective goggles, safety masks and ear protectors.

**DANGER**

Hot oil can contains combustion residues which are harmful to health. Risk of injury and scalding! Wear protective clothing, gloves and goggles/ safety mask. Avoid contact with skin. Do not inhale oil vapour.



DANGER

Because of the high temperature in the engine compartment, oil or fuel leaks can evaporate and create a serious risk of fire. Regularly check the integrity of the system.



CAUTION

It is absolutely necessary to view with RIVA the documentation of the different components provided by the Manufacturer; for any problem relevant to the use or maintenance, please directly refer to the RIVA After Sales & Service Department, listed in the documentation provided by the Manufacturer. In any case there are some small procedures that can be carried out by the crew on board, after consulting the operation manual.



ENVIRONMENT

Handle used fuel filters as special waste.



DANGER

Coolant is hot and under pressure. Risk of injury and scalding! Let the engines cool down and wear protective clothing, gloves and goggles safety mask.



CAUTION

Cold coolant in a hot engines causes thermal stress with the risk of formation of cracks in the components. Fill/top up only a cold engine.



CAUTION

If the oil level is not positioned between the two reference notches do not activate any device.

7.2 GEARBOX

The main functions of a marine gearbox are the following:

- Couple the engine with the propeller shaft and reduce the number of revolutions of the propeller;
- Reverse the motion direction;
- Interrupt the propeller shaft motion (idle).

The gear boxes are provided with several documents.

NOTE

For further information on use and maintenance, please refer to the manufacturer's manual.

7.2.1 Gearbox checks and maintenance

Component	Maintenance	Notes and precautions
Gearbox	Oil level check	For the correct maintenance and check procedures, refer to use manual delivered by the Manufacturer.
	Oil change	For the kind of oil and grade of viscosity recommended by the Manufacturer, refer to the gearbox plate.
	Oil filter change	Have the scheduled maintenance operations performed at the correct time schedule by authorized and skilled personnel, in order to keep the gearboxes perfectly efficient.



WARNING

The gearboxes are provided with emergency controls in case of fault. Refer to the Manual delivered by the Manufacturer.



CAUTION

The use of the gearbox with a low quantity of oil may damage the gears. An excessive quantity of oil may cause seals and vents to leak and can remarkably increase the operation temperature.



WARNING

Under normal operation conditions, the gear change can be carried out with the engine at low speed. However, in case of emergency, gear shifting can be carried out with the engine at high speed, thus remarkably reducing clutch life though.

Oil level check

The oil level check should only be performed when the engine and thrusters are stopped.

The proper oil level is between the upper and the lower notch of the dipstick. After the first oil filling, a repair or the cleaning of the oil filter, the gearbox must be run for about two minutes.

Next the oil level check has to be carried out again two minutes after the engine has stopped.

**CAUTION**

Before starting checking the oil level, check that the gearbox oil temperature complies with the normal operating specifications.

**ENVIRONMENT**

Recover waste oil following the norms in force, relevant to special waste disposal.

**DANGER**

Service the gear box only if engine and propellers are stopped and the thermal switch is OFF. Before starting the inverter, carry out the filling and the consequent check of the oil level.

The use of the gearbox with a low quantity of oil may damage the gears. An excess of oil might cause leaks to the seals and to the vent and increase remarkably the operating temperature.

7.3 SHAFT LINE

7.3.1 Propeller shaft and through-hull seal

The propeller shaft is fastened to the gearbox by means of the flange coupling and is aligned on the three points represented by the gearbox, by a water-lubricated stuffing box seal and by the shaft support.

The stuffing box case includes a piece fixed to the hull and an adjustable piece. The adjustable piece is closed to the fixed one, in order to compress the seal, located inside the stuffing box case.

It's very important that the seal disposal is compressed, in order to avoid irregular pressures on the seal seat that might compromise life and efficiency of seal disposal.

The outer shaft support includes a Neoprene bushing which uses the sea water as a lubricant.

Check it every season, as it might get worn quickly during cruising, especially in sandy waters.

The bushing wear causes a vibrations increase.

When the yacht is on a sandbank, a good technician can easily consider, by moving the shaft, if the wear demands the replacement of the bushing.



DANGER

Never approach the shafts while they are rotating.

7.3.2 Mechanical shaft seal

The mechanical seal has the function of preventing seawater from entering the yacht through the space between the propeller shaft and the hull.

Each seal consists of 2 main parts

- The seat;
- The rotary seal.

The seat, consisting of a fusion neoprene hard and tough, it is mounted on the bronze box in such a way as to remain fixed, while the shaft propeller rotates freely in its interior.

The rotary seal is bugged helix shaft until it touches the seat, and then fixed to the shaft and compressed to fit, thus creating a pressure between the seal and the seat.

Since the seal integral with the rotation of the propeller shaft, the pressure of contact with the seat forms a seal and prevents the dripping.

The seal is cooled and lubricated by the cooling water coming from the engine, and from here discharged to the overboard.

The seat was placed a clamp emergency protected by a safety seal used to prevent the unintended use of the clamp.

The emergency seal is recognizable by the cable tie of red color and should only be used in case of loss of the main seal due to a damage. To resort to the estate of emergency, you must perform some basic operations:

- Stop the rotation of the shaft;
- Remove the safety seal;
- Tighten the emergency clamp, to stop the entry of water on board.



CAUTION

Bleed the mechanical seals each time the yacht is hauled/launched.



CAUTION

Do not turn any circumstances the shaft when the clamp is tightened the seal of emergency.



DANGER

Do not approach the shafts when they are rotating.



CAUTION

In order not to compromise the seal, it is essential never to operate it without cooling water.



WARNING

Under normal operating conditions, reversing should be carried out with the engine at idle. However, in an emergency, reversing can be carried out with the engine at full throttle, but with a significant reduction in the lifetime of the clutch.

7.3.3 Shaft line checks and maintenance

Component	Maintenance	Notes and precautions
Shaft support bushings	Periodical checks (at least once a month) Assembly/disassembly	The Neoprene bushing of the shaft support, during navigation in waters with sandy suspensions, may wear rapidly. The bushing wear causes a vibrations increase. With the yacht in a dry dock, a good technician can easily evaluate, by moving the shaft, if the wear is so bad as to need the bushing to be replaced.
Stuffing box seal	Maintenance and check	With yacht moored at the marina, daily and before set up navigation.
Shaft lines	Periodical checks (at least once a month)	It is essential to keep always the propellers and shafts clean; the formation of parasites or the presence of foreign bodies like cables, cloths or plastic bags lead to propulsion power reduction, to propellers cavitation with consequent surface damage, and to vibrations causing damages to the stuffing box seals and to the bushings of the shaft supports. Checking and eventual cleaning may be carried out with the yacht in a dry dock or with the help of a diver. To clean scrape the barnacles, without engraving the metal, polish them with sand paper at thin grain.

MAINTENANCE

Each time the boat is launched / hauled, bleed the mechanical seals.

At least once a week check for water penetration.

At least once a month carry out the cleaning.

Periodically:

- Check the status of the seals;
- Check the compression of the seal and when necessary carry out the compression;
- Check and service the cooling circuit of the seals in order to prevent dirt, seaweeds and foreign bodies from blocking the cooling water flow, thus causing the seals to overheat and, consequently, their ir-reparable damage.

Check the shaft backlash (1) trying to move the shaft on a side back and forth to verify the backlash of the shaft supporting bushing (2).

Assembly/disassembly

- If the propeller shaft (1) shows backlash, the water lubricated neoprene bushing (2) could be worn out; in this case replace it.
- Remove completely the antifouling to reveal the screwdriver screws (3) which lock the bushing positioned.
- After the propeller (4) and the shaft (1) have been disassembled, by means of a plastic tube with a slightly smaller diameter, pull out the bushing (2).

For reassembly, repeat the above-mentioned operations in reverse sequence.

- Do not use grease between propeller shaft and bushing. Remember to fasten the screws (3).

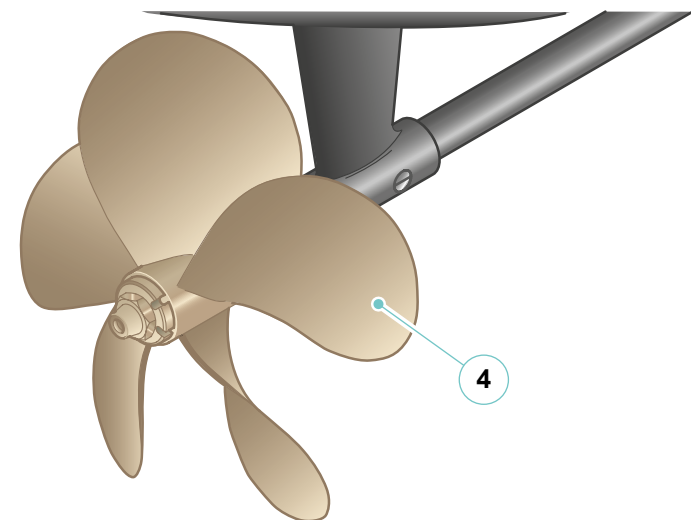
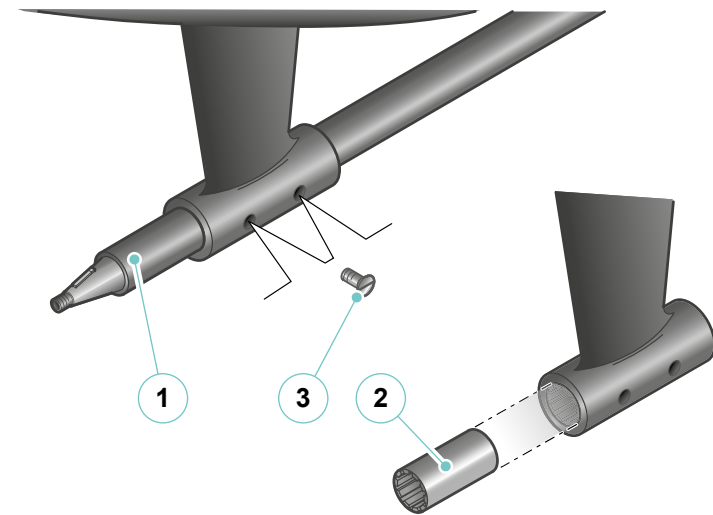

CAUTION

For spare part request contact the RIVA After Sales & Service Department.



CAUTION

Remember to retighten the fixing screws (3) of the bushing on the shaft support. Never use grease or other lubricant between propeller shaft and Neoprene bushing.

7.4 PROPELLERS

The propellers have been designed in order to result lightly “unloaded” with a new yacht, hull clean and without displacement overloads: in this way the engines will develop all their power in average normal operating conditions, with hulls and propellers not perfectly clean and some overloads on board.

Periodically check if the propellers are not too “dirty”, as this leads to a fast performance decrease and to a vibration increase.

In case of impact with the depth or submerged/semi-submerged bodies, check propellers and shafts immediately; in case of considerable vibrations, reduce the revolutions to the minimum and steer toward the harbor for repair, as a vibration increase might damage the propelling devices and the yacht structure.



CAUTION

RIVA yachts are designed to obtain a correct transversal trim with full optional equipment, and with spare propellers and shafts. If the yacht is not provided with full optional and with spare propellers and shafts, some weights are inserted to correct the transversal trim. The above-mentioned weights can be removed or displaced as soon as the yacht is provided with a new equipment.

7.4.1 Propellers check and maintenance

Component	Maintenance	Notes and precautions
Propellers	Periodical checks	<p>The propeller check should be performed according to the floating waters. Inspection and possible cleaning may be carried out with the yacht in a dry dock or with the help of a diver.</p> <p>Check if the propeller blades have notches, fractures, fouling or barnacles which may have a negative influence on the yacht performances during navigation.</p> <p>If you notice corrosion, check the anodes conditions and replace the propellers for major failures.</p>
	Assembly/disassembly	<p>The starboard and port propeller are not interchangeable between them neither with others as designed according to specific features of your yacht.</p> <p>Replace only with genuine spare parts supplied by the RIVA After Sales & Service Department.</p>

**DANGER**

For cleaning or inspection of propellers with the yacht in the water, disable engine start-up.

It is advisable to carry out this operation by yacht in dry dock because maintenance is in this way eased. Check if the propeller paddles show notches or breaks, scales or barnacles, which may have a negative influence on the yacht output during navigation. If you notice corrosion, check the anodes conditions and replace the propellers for major failures.

Propellers assembly/disassembly

The propellers (starboard and port) are not interchangeable between them; they are bronze meltings according to specific features of your yacht.

The extreme end of the shaft (9) is conical and a little key allows the coupling with the propeller (5) which must be inserted up to the shaft catch and leaving the propeller stretching out from the shaft plane of 2÷3 mm.

**CAUTION**

Do not replace the propellers of your yacht with other of doubtful origin. Contact the RIVA After Sales & Service Department. Each yacht model has its own propeller.

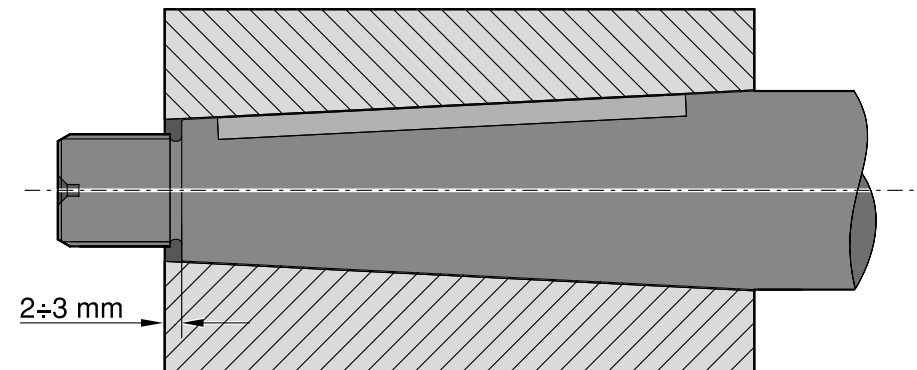

Pieces should not show burrs or dents to make the coupling effective. It is essential to lubricate them with plenty of silicon grease.

Tighten the nut (4) locking the propeller on the shaft (9); on the propeller hub there are three holes to 120°. Tighten as necessary to insert the dowel (3), to avoid natural loosening.

For disassembly keep an extractor at disposal so as not to deform the propeller.

In case of obstacles or excessive sticking, heat the propeller to expand the coupling and ease the removal.



CAUTION

Avoid the use of hammers or mallets to pull out the propeller. The pull out force must be uniformly exerted on the entire hub of the propellers.

Hereunder a list of the components of shafts and propellers line:

1. Screw
2. Propeller anode
3. Dowel
4. Nut
5. Propeller
6. Shaft support bushing
7. Shaft support
8. Countersunk screws with notch
9. Propeller shaft

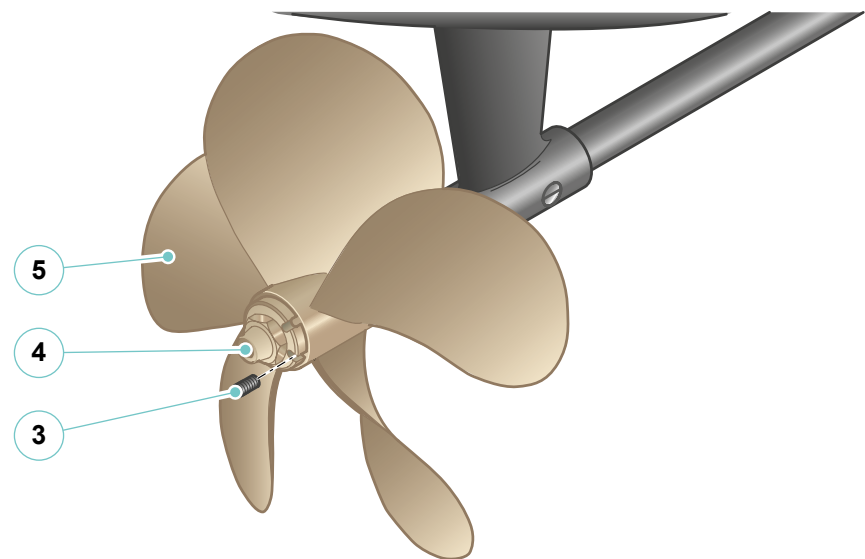
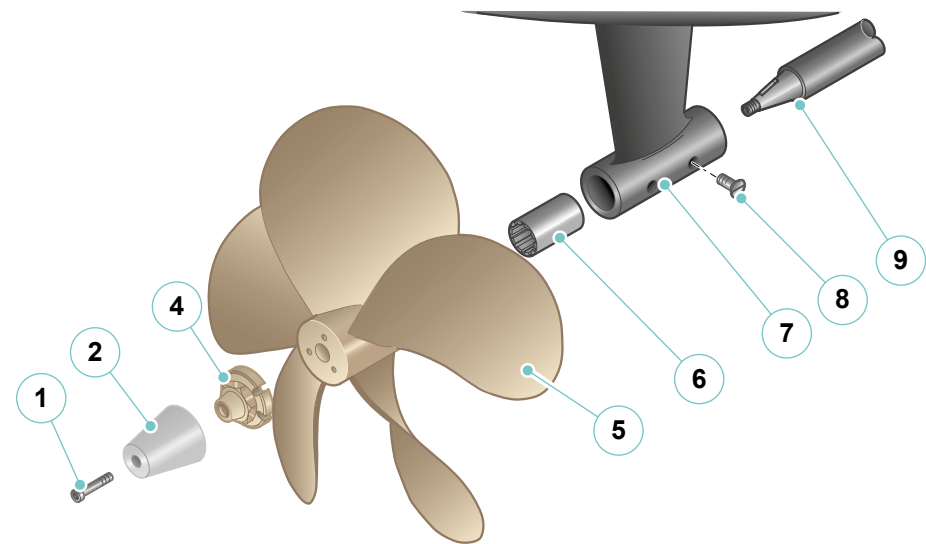

7.5 ENGINES EXHAUST SYSTEM

The engine exhausts are semi-submerged. This system reduces the fuel venting that would normally tend to foul the stern of the yacht.

The drains must be maintained and checked regularly to prevent the formation of deposits that could prevent the gases from escaping properly.



WARNING

When starting the engines, check that water comes out of the exhaust ports; this means that the engines cooling system works correctly and that the exhaust is cooled. Accelerate if no water comes out. If the problem continues, contact the RIVA After Sales & Service Department.



CAUTION

A strong smell and a light smoke from exhaust insulation are normal during the first period of use.

7.5.1 Maintenance of the engine exhausts

Component	Maintenance	Notes and precautions
Exhausts	Periodical check (as necessary, according to the floating area)	<p>Check the underwater exhaust terminal cleanliness conditions periodically. Clean, if necessary.</p> <div style="border: 2px solid yellow; padding: 10px; text-align: center;">  <p>CAUTION</p> <p>Carbon deposits, marine growths and fouling may affect the engine regular operation, causing performance degradation and serious damages.</p> </div>

MAINTENANCE

At least once every 3 months, tighten the bolts of the exhaust raisers.



CAUTION

Temperature sensors are installed on both engine exhausts. Illuminated warning lights on the helm position indicate that the temperature inside the exhausts is too high.



DANGER

Carbon Monoxide poisoning hazard

Ensure that the engine exhaust system operates correctly. Carbon monoxide is extremely toxic.

The exhaust system removes the combustion gas created by the engine and allows the correct ventilation of the stern.

Inspect the system tightness on a frequent basis. Leaks may permit carbon monoxide exposure.

7.6 FUEL SYSTEM

The fuel system of your yacht consists of:

- 2 tanks: located in the engine compartment;
- Tank connection piping;
- Fuel fill inlets;
- Water / fuel separator pre-filters.

The fuel supply lines to the engines branch out from the tank connection pipe.

The fuel delivery lines are fitted with a valve which is controlled remotely by a handle in the cockpit.

Before reaching the engines, the fuel passes through filters (2) which separate and remove impurities from the fuel.

Excess fuel which cannot be burned by the engines is returned back into the tanks via the return lines.

The tanks are filled by gravity through 2 openings (1), one for each side of the yacht.

The level sensors are positioned in the upper part of the tanks.

NOTE

Fill the tanks a few hours before departure.

Fuel impurities will settle and water will decant on the bottom of the tank since both are heavier than the fuel.

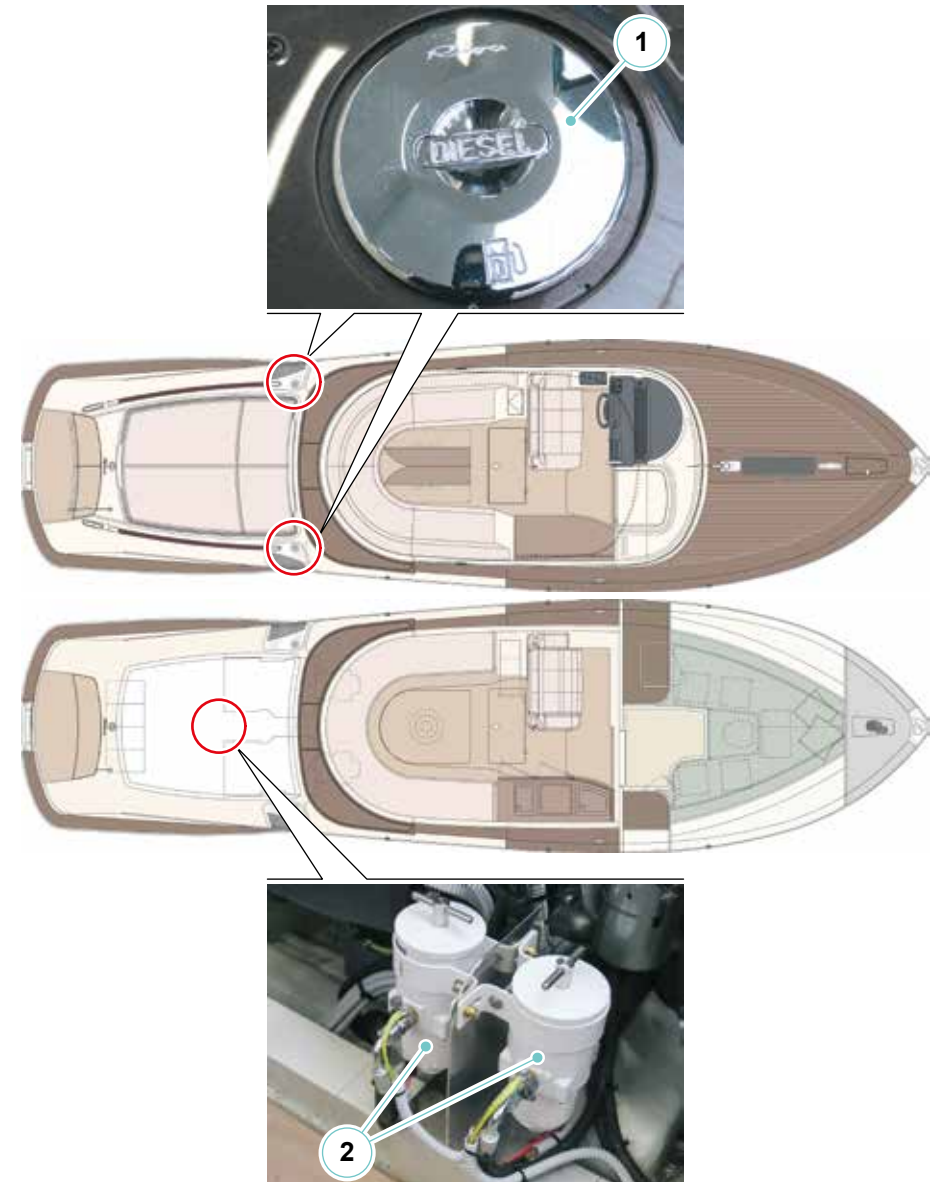

**WARNING**

The sensor reading can be distorted by the temperature, because the specific weight of fuel varies according to this last parameter and to the yacht trim.

**DANGER**

Because of the high temperature in the engine compartment, oil or fuel leaks can evaporate and create a serious risk of fire.

**DANGER**

A fuel leak can generate fire and explosion hazard.
Fuel cannot be stowed inside the garage.

**DANGER**

It is forbidden to smoke, use naked flames or keep mobile phones switched on during refuelling.

**DANGER****EXPLOSION/FIRE DANGER**

- Stow flammable material in a safety-approved container. Never stow flammable material in non-vented areas.
- Check bilge and engine compartment for fumes.
- Keep the ventilation system free of obstructions. Never modify the ventilation system.
- Inspect the fuel system for leaks.



**DANGER****EXPLOSION/FIRE/POLLUTION DANGER**

Fuel system connections that are too loose or too tight can leak, resulting in fuel loss, environmental pollution and explosion/fire danger.

**CAUTION**

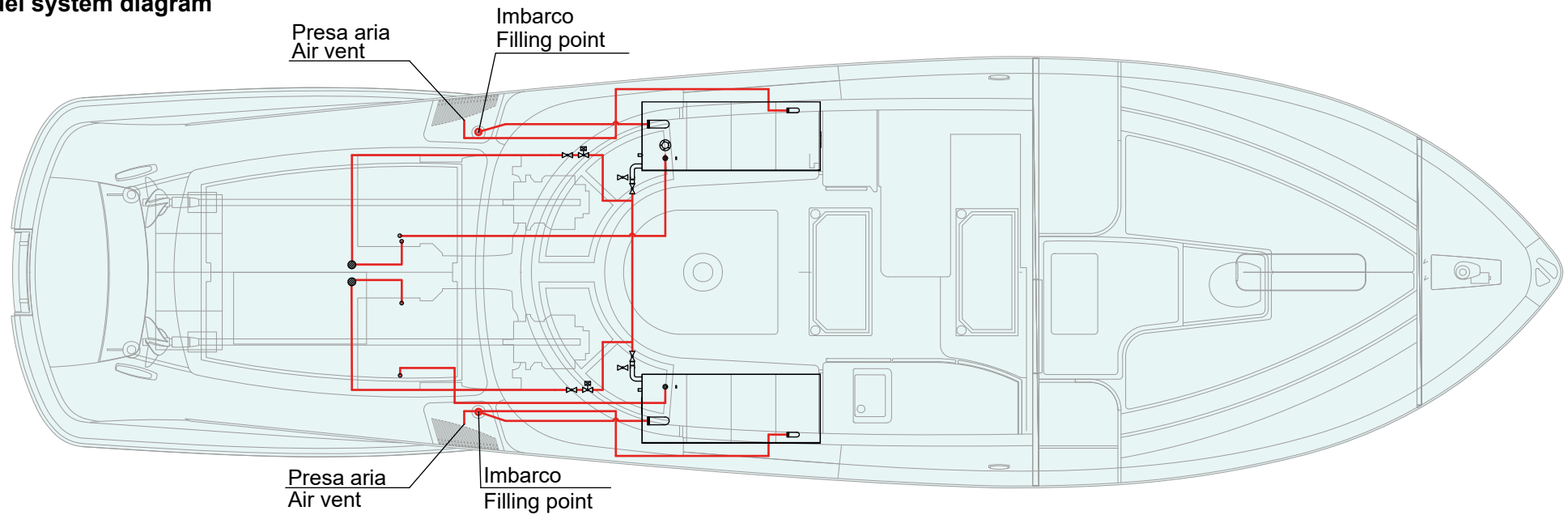
Be careful not to accidentally damage the fuel system pipes.
Periodically check all the fuel pipes.



ICONA ICON	DESCRIZIONE DESCRIPTION
	Valvola Valve
	Elettrovalvola Solenoid valve
	Filtro separatore combustibile / acqua Fuel / water separator

7.6.1 Fuel quality

For the good performance of the engines installed on your yacht, fuel quality is of primary importance.

Fuel should be purchased from reliable high-sale filling stations, for both the quality and a probable short stay of fuel inside the shore tank.

The fuels:

- European Standard EN590
- DIN EN 590 (Germany)
- ÖNORM EN 590
- ASTM D975 No. 1D (USA)
- BS 2869 Part 1 Class A 1 (United Kingdom)
- BS MA 100 DMX (Marine Diesel Fuel)

are suitable to supply the engines.

If the above type of fuel is not available in some countries, follow the rules indicated in the manual relevant to the engines.



CAUTION

Stop engines when refuelling.



WARNING

For the type of fuel to be used, follow the manufacturer's recommendations. Diesel engines require very clean fuel. Keep filters clean.



WARNING

If fuel containing water reaches the engines it can seriously damage the injection system. To avoid this, drain water from the fuel tank and service regularly the fuel/water separator filter.
During winter service do not use fluidity correctors.



CAUTION

It is recommended to empty and clean the tanks periodically and at least once a year.
Remember that reused fuel must be filtered.

7.6.2 Water/fuel separator filters for engines

Maintenance and water drain from collection tank

Bleed frequency or the replacement of the filter element (1) are determined by the contamination level of the fuel.

Check or drain the water collection tank (2) daily.

The collecting cup must be drained before polluting agents reach the turbine end, i.e. when the water detector (3) sends the alarm signal indicating the need to drain water.

- After having placed a capacious collection container underneath it, open the drain to discharge containments.
- Remove the cover (4) and fill with clean fuel.
- Close the cover and tighten the T-handle (5) firmly by hand.

Replacement of filter element

Replace the element according to the schedule recommended by the manufacturer or if a lack of power is noticed. Power loss indicates that the element is indeed clogged. Other factors such as overfilled tanks or excessively contaminated fuel can also clog the filter.

- Close the seacock.
- Remove the cover.
- Remove the element by holding the handle and by pulling lightly forward with a twisting movement.
- Insert a new filter having the same filtering features of the one replaced.
- Check and, if necessary, replace the filter cover gasket. Apply a layer of clean fuel or engine oil on the seal before reinstalling it, insert the new element with a slow twisting movement downwards.
- Fill with clean fuel, then replace the cover. Tighten the T-handle manually and reopen the valve.
- Start the engine and ensure there are no leaks. Repair any leaks with engine shut OFF.

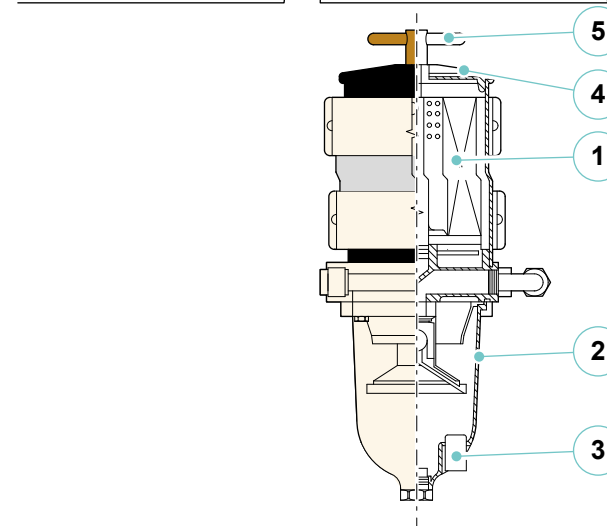

Troubleshooting procedure

The main reason for a poor start-up or lack of power is the result of a clogged filter or of an air leak in the fuel system. If the device does not prime or does not hold the idle run, or air bubbles are visible through the check glass, first of all check the cover by means of the T-handle and vent it, if it had not been closed properly. Then check all connections and lines and make sure that no fuel line is clogged with contaminants.

If the problem persists and the filter element is new, contact technical support.



CAUTION

The separators have to be checked at regular intervals as suggested by manufacturer, so as not to impair the engines operation.

MAINTENANCE

At least once a month check the operation. At least once a week, and anyway before each refuelling, check for the presence of water in the fuel. If necessary drain the water present. When necessary, but at least once a year, replace the cartridge of the filters.

NOTE

For further information on use and maintenance, please refer to the manufacturer's manual.

7.6.3 Fuel system maintenance

Component	Maintenance	Notes and precautions
Fuel tank	Bleeding (at least every two or three supplies and at least once a month)	Bleed the tank every 2 refuellings and at least once a month, in order to prevent condensate water and various impurities from entering the fuel circuit. Wait some hours from refuelling to allow impurities and water to deposit. Do not discharge bilge water containing bleed fuel into the sea, but collect it and discharge it to the appropriate areas on land for hydrocarbon disposal.
Separator filters	Cleaning and purging	Bleed the separator filters at least once a month in order to drain condensate water and various impurities collected in the special lower cup. Periodically replace the filtering element, increasing frequency if necessary.

7.7 BOW THRUSTER

The bow thruster is a very simple and strong device, but it requires some special care:

- The thruster must be used at a very low speed, or without fresh way; at higher speed, more correct reactions can be obtained with the offset use of the gear boxes;
- The Manufacturer, considering the excessive overheating, has foreseen a continuous run of max. 3 minutes. The electric motor is equipped with a built-in protection thermal switch, which stops the electric motor, in case it overheats and starts it again once it has cooled down. You should consider this when planning the manoeuvres to carry out;
- Each time the yacht is lifted, check the condition of the thruster, of the protection anode and of the fastening system.

The battery breaker located under the captain's seat is fitted with a manual two position button:

- ON: in this position, the battery breaker may be automatically closed/opened by respectively turning ON/OFF the thruster's control panel;
- OFF: in this position, the battery breaker is always OPEN, regardless of the turning ON/OFF of the thruster's control panel.

To close the battery breaker and have the thruster powered and ready for the manoeuvre, in general, it is necessary to:

- Position the automatic battery breaker to the ON position (button "extracted");
- Close the engine battery breaker;
- Turn ON the thruster control selector by simultaneously pressing the "ON" keys.

Use of the bow thrusters:

Before using the thruster, activate the battery breaker located under the captain's seat and the related magneto-thermal switch located on the main electrical panel. After activating the power supply, press the "ON" button on the helm position control panel.

The warning light indicates that the device is ready for use.

The thruster motor is controlled by the control selector.

When the thruster is no longer in use, press button OFF.

Before getting on land, disconnect the switch and the battery breaker.



DANGER

When using the thruster, be careful of any swimmers or other boats that may be in the vicinity of the manoeuvring thruster's area of operation. Do not test the thruster when the yacht is outside water, unless you are sure the workers are at safety distance from the thruster tunnel.



CAUTION

Always disconnect the related circuit breaker when the thruster is not in use.



DANGER

Always stop the thruster before carrying out checks or maintenance by disconnecting the magneto-thermal.

**CAUTION**

When the bow thruster stops supplying the thrust while the electric motor turns, there might probably be a fault in the transmission system. In this case, immediately disconnect the bow thruster.

**CAUTION**

Never activate the bow thruster longer than one second when the yacht is at dry shore, because this can damage the electric motor seriously.

**CAUTION**

When you leave the yacht, or during maintenance work on the thruster, you must turn all the battery breakers on board to the manual OFF position.

**CAUTION**

In case it is necessary to replace a fuse on the system thruster, to involve a technical competent naval electrician. Be sure to view the preliminary technical and operational documentation relative or contact RIVA After Sales & Service Department.

NOTE

For further information on use and maintenance, please refer to the manufacturer's manual.

Riva

AQUARRIVA *special*

STEERING SYSTEMS

CHAPTER 8

8.1 STEERING SYSTEM

The steering system of your yacht consists of 3 main parts:

1. Hydraulic pump connected to the steering wheel on the helm position.
 - This is an axial piston pump specifically designed for manual steering of the yacht.
 - The pump has a built-in valve block to prevent the rudder load from returning to the pilot. The valve block will not allow the rudder or the drive unit to move until it is moved with the steering wheel.
 - The valve block also includes a drain valve. This drain valve protects the mechanical components, pipes and hydraulic fittings from over-pressure.
2. Pneumatic cylinders.
 - These transmit the rotational force of the steering wheel to the rudder link bar and the rudders themselves.
3. Connection pipes.
 - These connect the hydraulic pump in the helm position to the pneumatic cylinders. The pressurised fluid within the pipes allows for rudder movement.

The system works as follows:

1. The steering wheel, connected to the steering pump, is rotated in the desired direction.
2. The oil is pumped through the pipes in the cylinder.
3. The cylinder rod, connected to the link bar, moves and causes rotation of the rudders, thereby changing yacht course.
4. The oil moved from the opposite end of the cylinder flows again through the connection pipes towards the steering pump.
5. When no course corrections are necessary, the integrated valve block keeps the rudder stationary.

NOTE

For further information on use and maintenance, please refer to the manufacturer's manual.

Riva

Steering system diagram

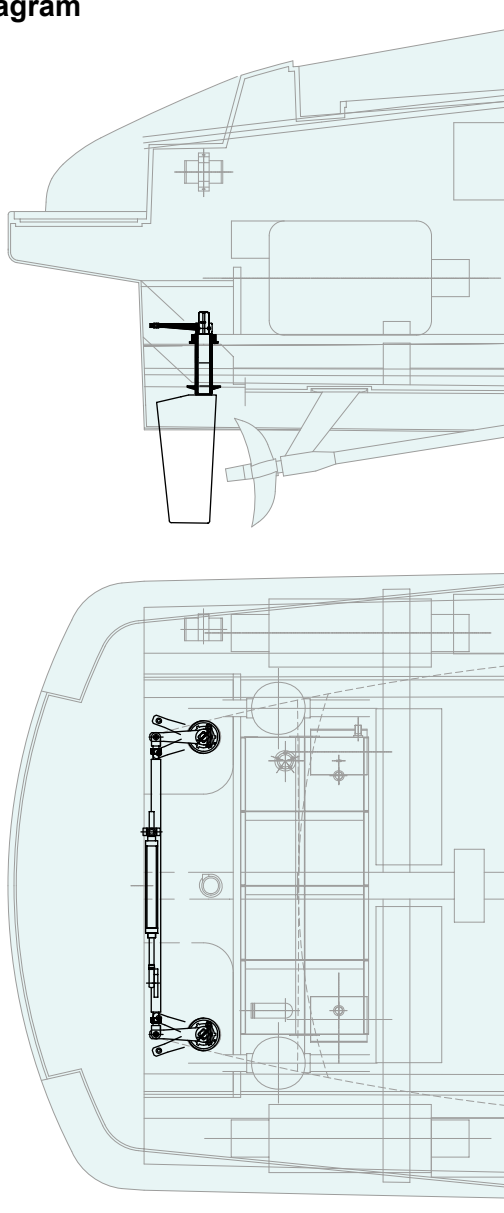

AQUARRIVA *special*

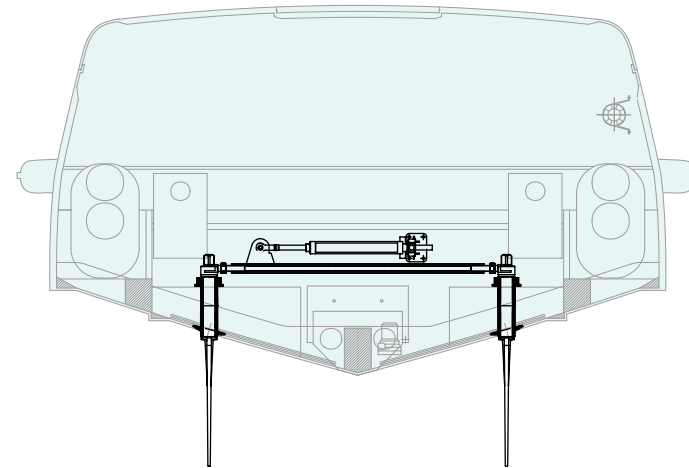

8.2 INTERCEPTOR

The yacht is equipped with interceptors, which can be controlled from the helm position.

They allow the longitudinal attitude of the yacht to be varied during navigation.

By lowering the interceptors you obtain the effect of lowering the bow towards the sea, vice versa by raising them the bow is raised.

This is necessary because in some cruising conditions, due to lateral forces (currents and wind), the yacht takes on an inclined trim by its very nature and to return it to the correct position it is necessary to counteract the action of the wind or sea currents with an action of the rudder.



WARNING

The use of the interceptors is quite normal during navigation, in order to make it more comfortable and to improve the yacht's performance.



CAUTION

Raise the interceptors completely during the reverse gear otherwise they might get damaged.

Some advice will prove useful to familiarize with the interceptor.

- In calm seas, the best position for the interceptors is the one that will allow you maximum speed with less friction of the yacht, as they counteract the evolutionary capabilities of the yacht. At medium speeds it is recommended to give a strong impact to the interceptors.
- In rough seas "in the bow", the interceptors "down" will allow you to "beat less" and cruise with more comfort even if the speed will be decreased.

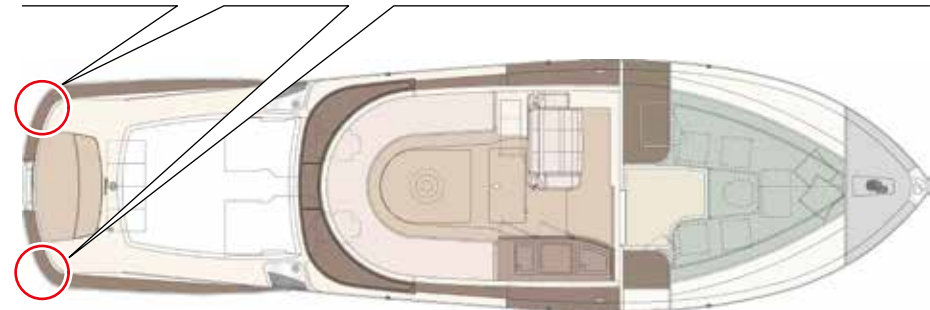

- In rough seas “in the stern”, the interceptors “up” will raise the prow thus avoiding unpleasant traffic jams.
- With lateral wave motion or asymmetric lateral load, the best stability is achieved with staggered interceptors.
- At the end of the cruise or when you stop, return the interceptors to the neutral position.



CAUTION

Interceptors can give sudden changes of direction to the yacht if they are operated too quickly. It is therefore necessary to test the response of these elements in the open sea and very carefully.



CAUTION

Always ensure that passengers are seated before making large adjustments on the interceptors, especially when cruising at high speed.

The electrohydraulic control unit for operating the interceptors is installed on the port side wall of the engine compartment.

NOTE

For further information on use and maintenance, please refer to the manufacturer's manual.

8.3 GYROSCOPIC STABILIZER (OPTIONAL)

To reduce the annoying effect of the wave-induced rolling motion, a system has been installed comprising a gyroscopic stabilizer capable of generating a rotation equal and opposite to that of the waves. The system provides a remarkable reduction of the pitch both with the yacht stationary or during navigation with low energy consumption that does not impair the quality of life on board and does not affect performance. Thanks to these important features, the device can also be kept on at night to allow a greater comfort by damping almost completely the annoying rolling motion.

The stabilizer devices are based on a well-known principle of physics: a gyroscope tends to maintain its vertical rotation axis, parallel to the acceleration of gravity.

When an external force attempts to vary the position of the stabilizer, such as roll caused by the movement of waves, the stabilizer prevents this action by rotating along an axis perpendicular to its own and that of the disruptive cause.

This generated operation (pitch) is reduced by means of two dampeners, duly calibrated according to yacht's features.

The system consists of a gyroscopic stabilizer (1) positioned at the centre of the engine compartment.

The gyroscopic stabilizer is controlled by means of the digital display (2) on the helm position.



CAUTION

Have the scheduled PERIODIC INSPECTION performed by skilled personnel every two years. Address to RIVA After Sales & Service Department for further information.

NOTE

For further information on use and maintenance, please refer to the manufacturer's manual.

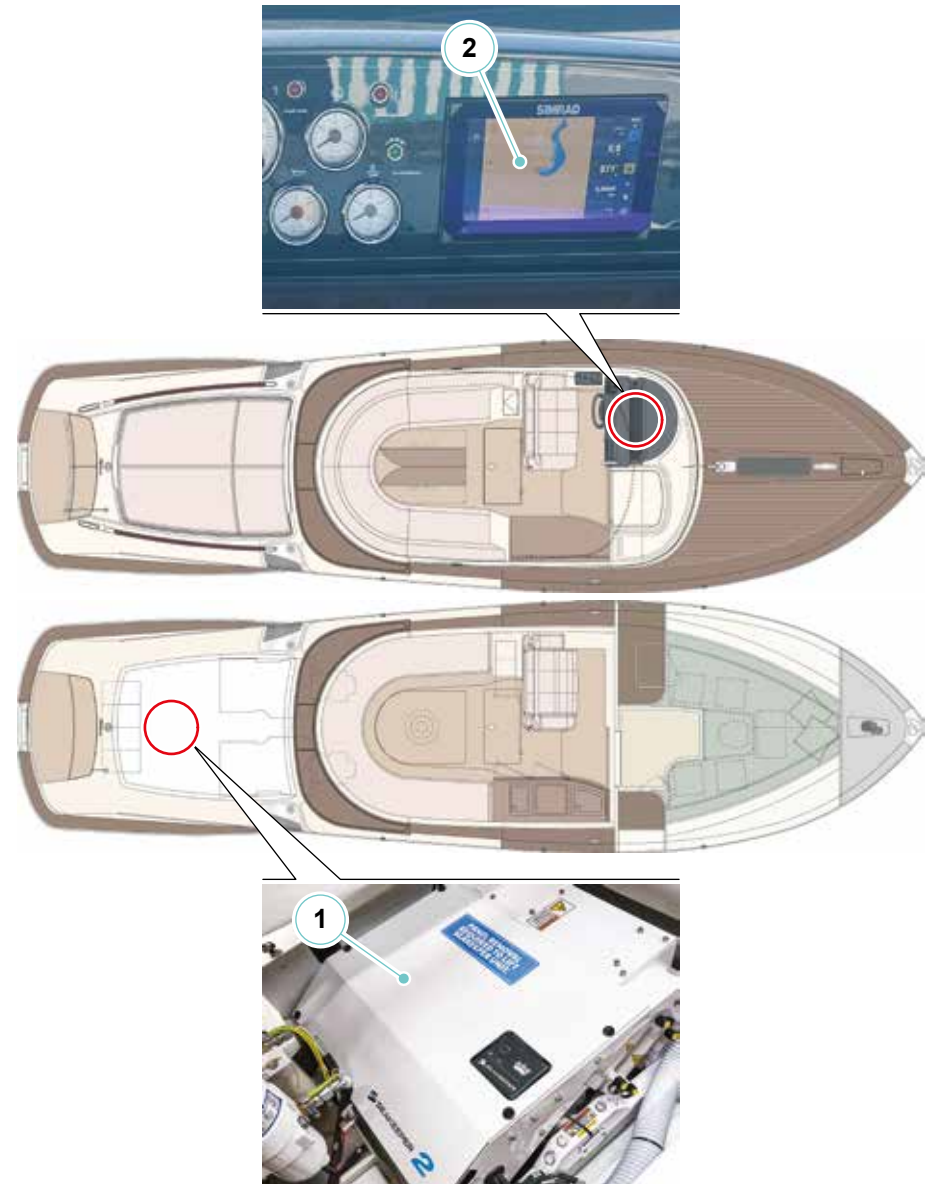

Riva

AQUARRIVA *special*

VENTILATION

CHAPTER 9

9.1 ENGINE COMPARTMENT VENTILATION SYSTEM

The ventilation system of the engine compartment allows the necessary air recirculation for the operation of the propulsion systems and of the machinery installed on your yacht, so as to keep a safe temperature inside the engine compartment.

The ventilation system consists of two lateral air intakes, which let air enter in the room and prevent the penetration of sprinkled water and of two extractors, withdrawing the inside air and conveying it outside.

Air extraction is activated automatically when the engine are enabled and is indicated on the side control panel on the helm position.

In the event of an emergency, the extractors are immediately stopped by activating the fire extinguishing system located in the cockpit.



CAUTION

While the engines are running, the extractor must always be activated. It is suggested to keep this ON for at least 30 minutes, after anchoring, to eliminate the residual heat.



CAUTION

Do not place any type of equipment or clothing on the air extractor or in the air intakes, as this may damage the rotating parts of the electric extractor or obstruct the passage of air.



DANGER

Carbon monoxide poisoning

Fossil fuel combustion generates a high quantity of carbon monoxide. This gas is a colourless, odourless and highly toxic. When the engines are running, the yacht must be properly ventilated, in particular if underway at low speed, or when the exhaust fumes may blow back on board (e.g. when the yacht is docked or anchored or riding the anchor).



CAUTION

Do not accidentally obstruct the external grates with any objects (such as towels, etc..).

Engine compartment ventilation system diagram

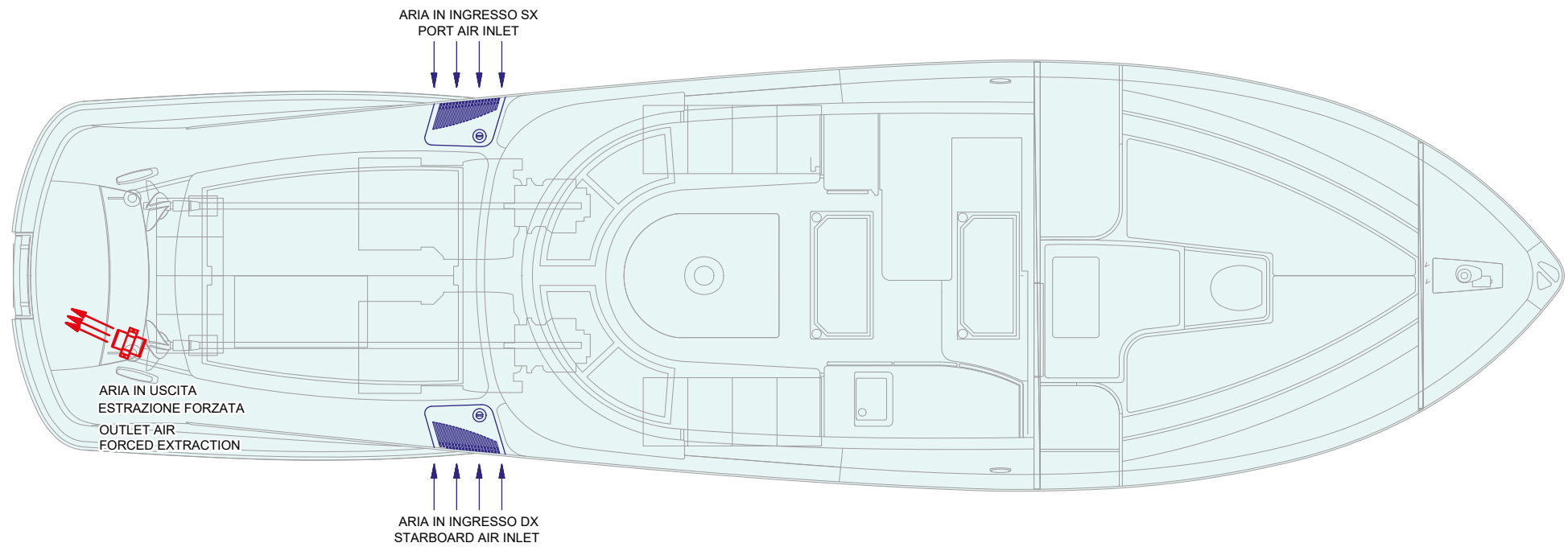

Riva

AQUARRIVA *special*

AUXILIARY EQUIPMENT ON BOARD

CHAPTER 10

10.1 PREPARATION FOR MOORING

Your yacht is equipped with instruments necessary for easy and safe mooring.

In addition to the windlass, the mooring equipment is located at the bow and stern and consists of:

- 2 mooring cleats at the stern of the yacht;
- The anchoring area at the bow tip contains:
 - One mooring cleat;
 - One deck fitting;
 - A locker containing the windlass.

1. Stern mooring cleats
2. Fender bushings
3. Bow mooring cleat
4. Deck fitting



10.2 ANCHOR WINCH

The yacht is equipped with an electric anchor windlass to drive the anchor housed in the bow.

The anchor chain enters the yacht and reaches the windlass, rides over the barbotin and enters the chain locker in the bow.

To power the winch it is necessary to activate the circuit breaker on the main electrical panel.

The windlass is equipped with a control for movement of the chain in both directions and a safety cable to lock the position of the chain when under way.



CAUTION

RIVA is exempted from any liability for any accidents or damage to persons or property caused by incorrect use of the device.

Anchor winch activation controls

It is possible to operate the winch positioned at the bow using the control button on the helm position or using the control panel located inside the bow locker.



CAUTION

If you intend to use the anchor, remove the chain lock safety cable.



CAUTION

Do not bring body parts or objects near the area where the chain, the line and the barbotin run.

Make sure the electric motor is not powered when acting manually on the anchor winch (also when you use the lever to loosen the clutch): people having the remote controls of the anchor winch (remote push-button panel) might accidentally activate it.



CAUTION

Lock the chain with its safety cable before setting up for navigation.



CAUTION

Do not operate the anchor winch electrically with the lever in the drum housing or in the barbotin cover.

Clutch use

The barbotin is connected to the main shaft by means of the clutch. The clutch opens (disengages) when the lever inserted in the bushing is rotated counterclockwise. When rotating clockwise, the clutch will close (engage).

Anchoring

The wind and the sea conditions highly affect an anchored yacht. Make sure the anchor is set in any situation. It is necessary to understand the principles of the chain length and its effect on the anchor performance.

The radius is technically defined as the ratio between the chain length and the vertical distance from the bow to the sea bottom.

The chain length depends on the type of anchor, on the sea bottom, on the tide, on the wind and on the sea conditions.

The chain length is 5 times the depth of calm sea; it is 7:1 in normal conditions and up to 10:1 in critical conditions.

$$\text{Radius} = \frac{\text{Chain length}}{\text{Bow height} + \text{water depth}}$$

as it is necessary to know the length of the chain to be used for mooring.

Chain length = (bow height + water depth) x radius

Anchor weighing

Start the yacht's engines. Make sure the clutch is engaged and pull out the lever. Press the control button available and start to weigh the anchor.

If the anchor winch stops without any reason, the anchor might be stuck and therefore the anchor winch thermal switch trips, due to the effect of the effort. In this case, if after several attempts the anchor winch remains stuck, we suggest to manoeuvre the yacht to release the anchor.

Check the raise of the last metres/feet in order to avoid bow damage.

Anchor lowering

Lower the anchor by means of the electric controls or manually. To carry out this operation manually, open the clutch and let the barbotin rotate freely on its shaft and the chain fall into the water. To brake the anchor chain fall, turn the lever clockwise.

To lower the anchor electrically, press the control button at your disposal. In this case the anchor lowering is perfectly controllable and the unrolling of the chain or of the line is regular.

Once the yacht is anchored, lock the chain with the safety cable.

The anchor and the chain may damage the yacht bow if the anchor winch is not operated carefully.

We suggest to carry out the operation by means of the remote control located near the anchor winch; this will allow checking the lifting and lowering speed of the chain and the entry and exit of the anchor shaft into the anchor roller.

Namely during those operations, an excessive gliding of the chain or a wrong entry or exit of the anchor shaft from the roller may cause damages to the yacht's bow.



DANGER

Do not use the on board auxiliary equipment for aims or ways other than those indicated in the manual delivered by the Manufacturer. Always deactivate the capstan winch when not in use to prevent accidental activation.



DANGER

Never get too close to moving parts to avoid danger and injury.

**CAUTION**

The anchoring area is a circle with the centre at the anchoring point and a radius equal to the chain length plus the yacht length.

The entire anchoring area must be free, in case of sudden variations of wind and/or current direction, especially in case of night anchoring.

At night, before dropping the anchor, check that the white anchor light works.

Before dropping the anchor, check the nautical charts: anchoring is prohibited in certain areas, in weeds covered sea bottom, anchoring is unsafe and harmful to the environment, on rocky sea bottom, the anchor may get stranded or lost.

Anchor the yacht with the engines running, both for safety reasons and to compensate the electrical consumption of the winch.

Check the anchoring point frequently.

The distance from obstacles or other yachts must be, at 360°, greater than the length of chain dropped.

During anchor riding it is advisable to leave the winch powered.

Do not reverse the winch rotation suddenly.

**CAUTION**

The anchor chain is fastened to the yacht by means of a line and an hook system.

If it is impossible to remove the anchor from the sea bottom, this system will ease up to resume navigation.

**DANGER**

When the winch is operating, be extremely cautious of rotating parts; keep your feet, hands and the remote control cable at safe distance.

Anchoring operations

- Make sure that the engines battery breaker is ON;
- Start the main engines;
- Turn the anchor winch switch ON, on the main electrical panel;
- When the key-pad is not used, disconnect it to prevent contact oxidation;
- Before operating the windlass with the electrical control, ensure that the barbotin clutch is tight and remove the chain lock hook;
- Let the yacht move backward slowly; if necessary, use the engines;
- Lower the anchor until just below the waterline, and hold;
- Lower the anchor until it reaches the sea bottom;
- Once the anchor holds, leave the lock and the brake engaged.

**CAUTION**

Operate the anchor winch with the engines running, in order to provide the high current required and reduce the stress by slowly moving the yacht toward the anchor.

Lower and raise the anchor always by using the electrical control, after engaging barbotin and barrel. The latter can be released to drop anchor if necessary.



CAUTION

The chain lock must be correctly inserted when under way.

Weighing the anchor

To weigh the anchor, perform the same operations previously described above, in reverse order.

In case of wind or current, we recommend using the engines as an aid in maintaining the heading towards the anchor position to avoid damaging the bow.

Once the anchor is on board, fasten the chain stopper before resuming navigation.



CAUTION

Prior to departing, check that the chain stopper is properly fastened.

10.2.1 Anchor winch maintenance

Component	Maintenance	Notes and precautions
Reduction motor	Check and cleaning (before each navigation)	When you weigh the chain, after an anchor mooring in a muddy or weedy sea bottom, we advise you to wash the chain using the proper system. The outer part of the winch requires frequent washes with fresh water because very much exposed to sea salt during navigation specially with choppy sea.

Reduction motor



CAUTION

Before carrying out any maintenance operation on the anchor winch cut out electric power connected with it and remove with care the chain from the barbotin.



CAUTION

If the outside temperature is low, it is advisable to run the winch at idle (unloaded) for about a minute before use in order to warm the lubricating oil in the gear motor and increase fluidity.

Remove the layer of salt, which builds up on the anchor winch outer surfaces as soon as possible, to avoid dangerous corrosion, which could jeopardize its integrity.

Wash with fresh water and clean the surfaces, particularly those hidden and hardly reachable and into which the salt remains trapped.

At least once every two months disassemble the exposed parts, clean and check all pieces so that they do not show signs of corrosion and grease the thread of the shaft with sea grease.

In case of anchor winch long inactivity, we advise you to have the motor run idle for a couple of minutes in both directions.

If the electric motor turns with problems we advise you to clean or replace the brushes.

We strongly recommend to separate the anchor winch from the main deck at least twice a year to remove the salt deposits building up under the base.

10.3 ENGINE HATCH SYSTEM

To lift the hatch, use the button (1) on the side control panel.
If is not necessary to move the engine hatch, deactivate the relevant circuit breaker on the main electrical panel.



10.4 WINDSCREEN WIPER SYSTEM

To ensure proper visibility in all weather conditions, your yacht is equipped with an efficient windscreen wiper system.
The system is powered at 12V and the two wiper blades are operated by means of mechanical arms.

The windscreen wiper system is operated by a designated button (1) on the helm position.

If you need to use the windscreen wiper system, you must first activate the circuit breaker on the main electrical panel.



10.4.1 Windscreen wiper system maintenance

Component		Maintenance	Notes and precautions
Windscreen wiper blades	Cleaning	Clean accurately with fresh water after each navigation return. Clean periodically the windscreen wiping blades using specific detergent or alcohol. Apply Vaseline oil on the blades and grease the arms springs with silicone grease.	
	Replacement	Replace the windscreen wiper blades at least once a year with original spares. If necessary and if the blade rubber results to be deformed or worn out, replace them more frequently.	



WARNING

During the cleaning or maintenance operation, make sure that nobody can operate the windscreen wiping system causing damages to persons.



CAUTION

Do not remove foreign bodies activating the blades when the windscreen is dry.



CAUTION

With very harsh weather, and with the freezing risk, detach first the wiping blades from the windscreen surface.
Before activating the windscreen wiping system make sure that ice has not stuck the blades on the windscreen surface; if necessary to spray an anti-freezing agent to detach them.

10.5 BIMINI

Your yacht is equipped with an electrohydraulic bimini to provide shelter for the cockpit area.

The electrohydraulic unit that controls bimini movement is located in the cockpit bilge.

To open/close the bimini, activate the relevant circuit breaker on the main electrical panel.

The bimini is moved by pressing and holding the button on the side control panel; movement is accompanied by an acoustic signal.

Once the bimini is fully opened, secure it with the tensioning buckles supplied and stowed in the engine compartment. Connect the buckles to the fore hooks on the windscreen and the aft hooks on the fender.

Before closing the bimini, remove the belts and store them in the holders located in the engine compartment.

NOTE

Do not use products containing solvents to clean the bimini canvas as these may compromise the canvas surface treatments.

NOTE

The function of the bimini is to provide protection from the sun; remove any water deposits that may form on the bimini immediately. Any water remaining between the mounts for an extended period of time can cause dirt and the permanent deformation of the fabric due to the added weight.



CAUTION

During bimini positioning, guests must remain seated on the sofas of the cockpit to avoid the possibility that any loss of balance might lead them to grab parts of the bimini not designed to resist abnormal stresses.



DANGER

During the opening / closing phase, the captain must take care to ensure that guests are not present in hazardous areas, particularly within the bimini's range of motion.



DANGER

Release the bimini completely by holding down the appropriate button and stop only in case of emergency or hazard.



DANGER

Be careful not to place hands in the bimini cavity during closure.



CAUTION

Never open the bimini during navigation.
Only open when the yacht is stationary so as to avoid a “sail effect”, which could damage the structure or cause injury to persons.
Do not open the bimini in adverse weather conditions.



CAUTION

Never press the bimini closing button without removing the fore and aft fastening straps.



CAUTION

When washing the yacht, never direct high-pressure water jets onto the canvas surfaces as doing so may deform the seams.

10.6 COCKPIT TABLE (OPTIONAL)

In the stern cockpit there is table (2) that can be adjusted in height using electric actuators.

The table controls (1) are located on the helm position.



DANGER

Moving parts: be alert, always keep hands and feet at a safe distance. Do not insert any object between the structure and its seat.



CAUTION

Do not sit on the table while it is in motion. This could compromise the functioning.



DANGER

During cleaning or maintenance operations, make sure that nobody can activate the table, because this can cause heavy injuries to persons; we recommend disconnecting the electric power supply.

NOTE

For further information on use and maintenance, please refer to the manufacturer's manual.

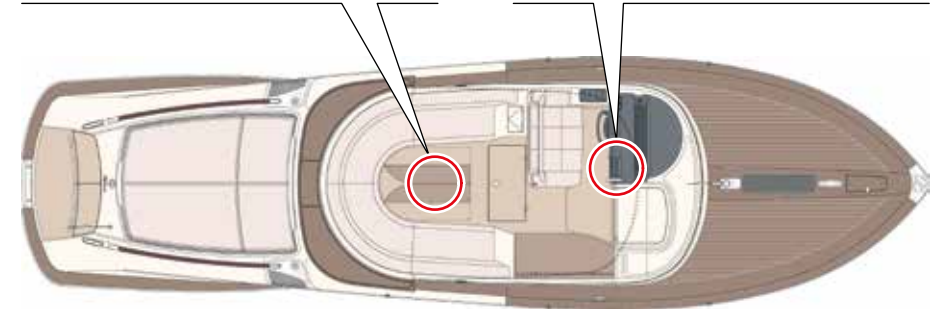

10.7 SWIM LADDER

The yacht is equipped with a manually extractable ladder (1) which allows an easy access from the sea to the stern platform, and vice versa.

To prevent the swim ladder extension during navigation, it is provided with a manual lock.

The swim ladder is retracted inside the structure of the stern platform, so as not to hinder navigation and mooring and unmooring operations.

The swim ladder does not require ordinary maintenance; anyway, being particularly exposed to sea corrosion, it is advisable to wash it accurately with fresh water after each use.



DANGER

Never start navigation with the swim ladder not correctly retracted and locked.



CAUTION

Never use the swim ladder when the engine is running.



DANGER

Pay attention to moving parts and to your hands.





CAUTION

Make sure that the swim ladder is correctly extracted and positioned before going down to water.



CAUTION

Pay attention because the ladder can be slippery. Ensure a safe grip before climbing on board.



DANGER

Risk of electric shock from leakage currents. Never swim in waters near harbours or marinas.



CAUTION

Never start navigation if the swim ladder is not correctly retracted.



WARNING

For a safe use of the yacht, when you are stopped at open sea and you are alone on board, always keep the swim ladder open.

Riva

AQUARRIVA *special*

INFORMATION FOR USE

CHAPTER 11

11.1 GENERAL INFORMATION

This part of the manual describes some basic rules to keep in mind at all times in order to enjoy your yacht safely.

- Make sure that safety equipment is perfectly efficient and available to each passenger.
- Keep a safe distance.
- Check that all yacht safety equipment on board is in good condition and no maintenance activity is overdue.

NOTE

The manufacturer provides some of the international equipment required the owner will have to equip the yacht with devices required by national laws.

- In case of using the fixed fire-fighting system: do not ventilate the engine compartment, until the fire has been completely extinguished.
- Ventilate the engine compartment before entering. Ventilate the lower deck compartment before entering, if portable extinguishers have been used.
- Oils, used filters, emulsions, coolants and electrolytes are all harmful products: avoid contact with the skin and dispose of them carefully.
- In the engine compartment, be cautious with hot and moving parts.
- Wear hearing protection when entering the engine compartment.
- Do not use open flames and do not smoke, when handling fuel or lubricants.
- Do not scatter fuel in the environment.
- Change the fresh water in the tank frequently and treat with bactericides.
- Do not exceed speed limits in harbours or confined waters.
- Reduce speed in the proximity of other yachts or swimmers.
- Adjust speed according to sea conditions.
- Reduce speed before entering the engines room. Modify the course, if necessary.

- Before connecting the shore connection, make sure that the switches on the panel in the engine compartment are not activated.
- Before leaving the yacht, turn the battery breakers OFF.
- Handle hot oils carefully, in order to prevent serious burns.
- Do not work on engines or shaft lines without first disabling their start-up.
- Do not inhale exhaust fumes: risk of serious injuries or death.
- Before disconnecting a battery, check if the battery charger is operating. If it is, disconnect it and remove the negative wire first and then the positive one. When reconnecting the battery, follow the same steps in reverse order (the positive wire first and then the negative one).
- Replace any part showing signs of corrosion immediately.
- Do not disconnect the batteries while the propulsion engines are running.
- Do not disconnect the batteries while the generator or propulsion engines are running.



DANGER

The responsibility for the operation of each boat lies solely with the owner. It is the Owner's direct responsibility to ensure, prior to departure, that the safety equipment required by law is present on board and fully functional.



DANGER

We recommend that you read the safety instructions in this manual carefully before you set off on your voyage and before operating the various on-board devices.

11.2 PRECAUTIONS FOR HARSH CLIMATES

Regularly check that all equipment and machinery containing water is protected with the correct proportion of non-toxic antifreeze.

If the outside temperature is below or close to 0°C (32°F), the fresh water and sea water systems run the risk of freezing.

Piping and hoses may break from freezing and this could lead to the yacht sinking.

Systems prone to freezing also include freshwater and saltwater cooling systems.

For more information on the maintenance and service requirements of your yacht and its equipment, and for special information about maintenance in cold weather, see the sections in this manual that refer to the single components, devices and equipment, but be sure to consult the User Manuals provided by the Manufacturers for specific information.

11.2.1 Cooling system

The antifreeze liquid is advised for all kinds of climates: it increases the working temperature range, lowering the freezing point and increasing the boiling point.

When the temperature comes close to 0°C (32°F) it is necessary, in order to avoid the risk of freezing, to make sure that the cooling lines are filled with antifreeze mixture. If not, replace the cooling liquid with such a mixture.

Before filling the system with antifreeze mix, it is necessary to wash the cooling circuit.

Engine cooling systems should be filled with a mixture of 60% water and 40% antifreeze throughout the year to ensure protection against corrosion and freezing down to -27°C (-17°F).

At the beginning of the cold season, the antifreeze content of the coolant must be checked and increased according to the expected outside temperatures.



ENVIRONMENT

Concentrated coolant must be treated as special waste.

When disposing of used coolant, abide by the regulations of the local authority.

NOTE

For information concerning the type of anti-freeze or additive to be used, please refer to the technical documentation supplied by the Manufacturer.



CAUTION

Do not use only water as a cooling liquid, as it is corrosive at the engine operating temperatures and does not protect suitably against boiling and freezing.



CAUTION

We recommend you to use technical liquids approved by the system Manufacturer. Always avoid antifreeze concentration to drop below 40% in volume. Replace the whole cooling liquid according to the schedule indicated by the Manufacturer.

11.2.2 Fuel system

With low temperatures, diesel fuel can form some solidified paraffin suspensions which can clog the fuel filters; making the normal engine supply impossible.

Fuel as per European standard EN590 guarantees fluidity up to 0°C during the summer period, and up to -20°C during the winter period.

**WARNING**

There is a special type of fuel for countries subject to very low temperatures.

**CAUTION**

Do not add petrol to fuel, in order to avoid serious engine damage.

NOTE

For further information on use and maintenance, please refer to the manufacturer's manual.

11.3 PREPARING FOR NAVIGATION

Preliminary checks:

Below are some important points to consider when preparing for departure:

- Check that the safety equipment on board is operational, in good condition and conforms with the regulations of the place of destination;
- Check that the bilge pumps on board are working properly;
- Check the cleanliness of the seawater filters; if they are dirty, close the seacock valves at right angles to the pipe, remove and clean the traps, reinsert them by carefully closing the filters, then reopen the seacock valves.



CAUTION

After reopening the valves, check that there are no leaks.

- Check the tension of the V-belts on the motors; restore correct tensioning if necessary;
- Check the engine and inverter oil levels; top up if necessary;
- Check the engine coolant levels; top up if necessary;
- Check the cleanliness of the fuel system separator filters;
- Check the hydraulic oil levels; top up if necessary;



CAUTION

To check and top up fluids, please refer to the specific manuals provided by the manufacturers.

- Check the liquid levels (fuel, freshwater) in the tanks;
- Check that moving parts on deck and below deck are properly secured;
- Check that the load distribution is such as to maintain the correct trim of the yacht.



DANGER

The owner of the yacht must ensure that all persons on board are familiar with the location of the safety systems (fire extinguishers, life raft, life jacket, etc..) and the correct way to use them.



DANGER

It is advisable to always carry out safety equipment checks before each voyage; these checks are useful not only for checking the condition of the equipment but also for memorising the locations and procedures for use. This short task may prove very useful in case of need.

- Check the operation of the rudder (move from side to side, check correct operation, then return to centre).
- Check the operation of the interceptor.
- Operate both interceptors. When not in use, these should be left in the neutral position.
- Check that the navigation lights are switched ON and the horn is working.
- Check the proper function of the windlass again.
- Check the efficiency of the on-board instrumentation.
- Check the hatches are closed.
- Check the operation of the bilge pumps and their indicators.
- Ease the yacht's moorings and check that there are no obstructions to unmooring.

- Check that the engine compartment extractor is operational.
- Check that no inflammable or improper materials have been stowed in the engine compartment.
- Check that the sea inlet valves for engine cooling are open.
- Check that the engine cooling circuits are in operational mode (valves open).
- Check that the engine fuel circuit is operational (valves open).
- Disconnect the shore power socket.
- Engage the engine and service battery cut-OFF switches.
- Check the charge status of the batteries via the electrical panel; recharge if necessary.
- Engage the 12V utilities on the electrical panel.
- Disconnect unused utilities, after ensuring their correct operation.
- Start the engines with the inverters in “neutral”.



CAUTION

The battery charger must be switched OFF when the engines are running.

11.3.1 Weather

Learn to understand weather patterns and signs of change. Bad weather and sea conditions can cause an uncomfortable and unsafe situation. Here are a few basic weather-related rules:

- Check the forecast and sea conditions before leaving and while underway;
- A sudden change in wind direction or speed, or an increase in wave height indicates deteriorating weather;
- If a storm approaches, immediately seek a safe harbour;
- If a storm hits, head the bow of your yacht into the wind;
- If you encounter fog, determine your position, set a safe course, slow down and alert other boats of your presence with a sound signal.

11.4 FIRST PERIOD OF USE

During the first period of yacht operation, in addition to the normal maintenance and check operations indicated in this manual, we recommend carrying out the following additional operations and more accurate checks.

The duration of this period varies according to the frequency and use modes, but are in any case suitable to allow a correct run-in of all systems and components on board.



WARNING

We recommend consulting the technical documentation provided by the Manufactures of the various on-board systems and components; they can indicate operations, checks and specific times not included in this Manual.

Following the first period of use, the hereunder listed additional operations and checks, should be performed at longer time intervals, although in any case, they play an important role for the safeguarding and reliability of the yacht and navigation safety.

- It is recommended that new or overhauled engines should not be operated above 75% of their maximum load and at variable speeds. After this initial run-in, the engine should be brought up to full output gradually.
- After starting each engine, check for the correct circulation of the cooling water inside the circuit, by verifying that it comes out of the drains. Check also for the presence of leaks from the sea cock valves and strainers of the cooling circuits.
- Before the engines start, check the correct tension of the V-belts.
- Check the possible presence of unusual noises from the engines exhaust.

- Before and after navigation, check for possible leaks in the shaft lines.
- During navigation monitor constantly the temperatures and operation pressures of the devices on board (propulsion engines, gear boxes).
- Check, by means of indicators installed on the electrical panel, the correct charge condition of the batteries starting the engines and the utilities. Moreover, the engine alternators must correctly charge the batteries.
- Check rudder efficiency (by often checking the tiller angle) and the interceptors.
- Before and after navigation, check the correct oil level in hydraulic systems such as the rudder system and interceptors.
- Check the correct load level of all extinguishers (fixed and portable) installed on board; the indicator needle on the pressure gauge should be set in the green range.
- Check the indicator of the main pressure gauge for possible pressure drops inside the system.
- Before and after navigation, check the correct operation of all bilge pumps on board.



DANGER

Before performing the listed checks and maintenance operations, we recommend carefully reading the Safety Rules relevant to maintenance, contained in this Manual.



WARNING

Should more or less serious faults be noticed, contact the RIVA After Sales & Service Department as soon as possible.

**CAUTION**

RIVA declines all responsibility regarding tampering carried out by third parties on equipment installed in the Shipyard. Such tampering or unauthorized installations will not only immediately void the warranty, but may cause damage to the yacht and injuries to the people on board.

RIVA declines all responsibility concerning periodical maintenance activities scheduled by the Shipyard or by Manufacturers, but not carried out, on equipment/components, for which it is necessary to refer to their own Technical Manuals.

11.4.1 Engine drive

Despite the yacht's efficiency and high performance, the use of this yacht requires careful and responsible conduct.

The minimum gliding speed is influenced by the displacement, the distribution of the weights on board, the position of the interceptors and the conditions of the sea. An excellent compromise between transfer speed, comfort and consumption is obtainable with about 1500/2000 rpm less than the maximum allowable revolutions.

Do not keep the propulsion engines at idle for a long time; in this way they do not become "dirty" or overheated.

Avoid harsh accelerations or decelerations to avoid excessive stresses for the engine turbines.

When the yacht reaches the cruising speed, the engine check instruments should set to constant values.

If the instruments show contrasting or abnormal indications during continuous run, check for failures of the systems or of the equipment and contact RIVA After Sales & Service Department.

**CAUTION**

Set the speed of the yacht and the interceptors position according to the conditions of the sea and the prevalent direction of the waves; in this way the structure of the yacht does not undergo to useless stresses and the passengers can enjoy more comfort during navigation.

In the passage between displacement and gliding navigation there is a critical phase to be carried out as quickly as possible, as it is characterized by high consumption and more vibrations; it also causes a very deep wake.

**DANGER**

It is absolutely forbidden to perform reverse run with one of the two engines stopped.

This operation is allowed only in case of life danger for the persons on board and for the safety of the yacht itself, however when the engine is running it should not run higher than 1000 rpm.

**WARNING**

Avoid prolonged use of engines at low speeds to avoid overheating of the exhaust pipes due to reduced cooling water circulation.

11.4.2 Refuelling

Fuel must be loaded through the fill inlets (1) located on the sides of the yacht between the cockpit and the aft sundeck.

The filler cap is marked “DIESEL” to prevent the accidental introduction of improper liquids.



CAUTION

Gravity refuelling and not pressure refuelling should be used to avoid damage to the system.

Before loading fuel:

- Shut down the engines.
- Prevent access to the area near the fill inlets and vents.
- Have a fire extinguisher and hydrocarbon absorbent material at hand.
- Wet the area near the fill inlet with water.
- Check that the vents are free.
- Determine the required amount of fuel to be loaded.
- Open the lid of the fill inlet.
- Check that the supply pump is of suitable size.
- Insert it into the fill inlet, holding it firm.

During refuelling, air vents must be monitored to ensure that there are no accidental fuel leaks due to the formation of foam or air pockets. When refuelling is almost complete, it is advisable to proceed with frequent breaks to allow any foam to dissipate.

Once refuelling is complete, screw the fill inlet cap back in and use absorbent material to dry any fuel droplets that may have leaked.

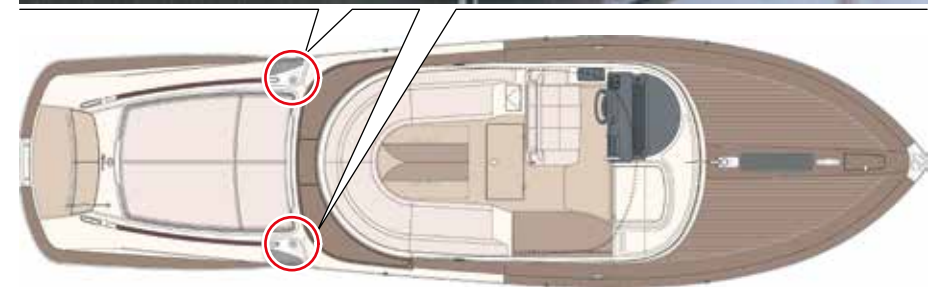



ENVIRONMENT

Do not dispose of fuel in the environment to avoid causing pollution. Dispose of waste contaminated by fuel in accordance with applicable regulations.



CAUTION

It is suggested that you refuel upon returning to port to allow the fuel to cool down without forming condensation. Bleed the tank after every 2 or 3 refills.



CAUTION

For the type of fuel to be used, follow the manufacturer's recommendations. Diesel engines require very clean fuel. Keep filters clean.



CAUTION

When refuelling, open the filler necks on both sides of the yacht.



DANGER

The fuel is flammable and explosive.

During refilling:

- Smoking is prohibited.
- The use of naked flames is prohibited.
- Mobile phones must be switched OFF.
- Do not leave the yacht unattended.
- Do not leave the propulsion engines running.

Failure to comply with these precautions may result in fire with the risk of serious damage to persons or property.



DANGER

Fuel leaks create a fire and explosion hazard.



CAUTION

Stop all engines when refuelling.

11.5 WATER SUPPLY

Proceed as follows:

- Ensure the yacht is properly moored; we suggest stopping the engines, if running.
- The water supply fill inlet (1) is located at the stern of the yacht.
- Loosen the filler cap and insert the hose (it must have suitable dimensions).

At the end of filling, remove the hose and tighten the filler cap.



CAUTION

Frequently change the water in the fresh water tank and disinfect it with suitable products if necessary. Avoid leaving the tank completely full if there is a risk of freezing.
Do not leave the yacht unattended while filling.



CAUTION

The filler cap is marked "WATER" to avoid accidental introduction of different liquids.
To avoid damage to the system and tanks, we recommend replenishing by gravity and not by pressure.



CAUTION

Before refilling the fresh water tank, check that the water coming from the shore system is drinkable.

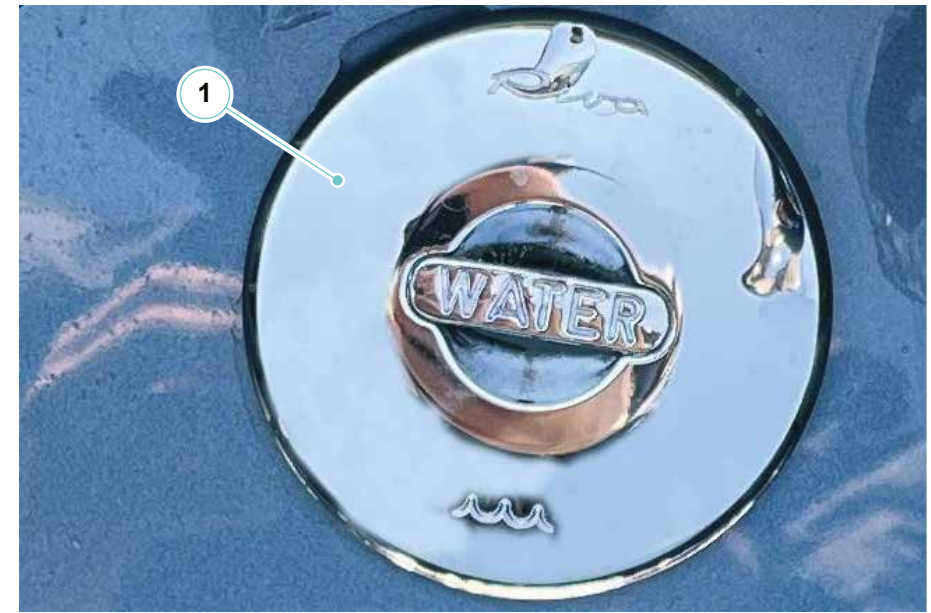

11.6 UNMOORING AND MOORING



CAUTION

Before the unmooring operation, ensure that engines, gear boxes, rudders and bow thruster are in good working order. During such manoeuvres, the Captain should prevent any unpleasant noise, and/or wake that might bother other people. Before unmooring, make sure that all doors, hatches, etc., are closed.



WARNING

Before starting the manoeuvre, make sure that people on board, especially children, do not obstruct operations and that they stay in suitable places.



DANGER

Check with extreme care that no one on board is in danger (with legs or arms outside the edge, in precarious balance or moving on wet or slippery surfaces) and that the fenders are well positioned and fastened.

The yacht is equipped with powerful engines, highly efficient rudders and a high-performance thruster.

The thruster must be used at a very low speed or without overheating; at a higher speed, more precise reactions are obtained with the staggered use of the engine control lever.

The ability to exploit these excellent qualities depends mainly on the “familiarity” the Captain has with his yacht.

Manoeuvre at a reduced speed to allow the necessary reaction time, so that you can better assess the situation at any given moment and, in the event of unforeseen circumstances, to avoid damaging your yacht or those of others.

Before unmooring check following:

- There should be no other boats manoeuvring;
- The mooring lines must not be snagged;
- The fenders should be in place and well secured (in the event of wind or undertow, equip a passenger with fenders to avoid damage);
- There must be no floating objects or loose lines that could damage the propellers;
- The shore power cable must be disconnected and stowed.

11.6.1 Leaving the mooring

The yacht is steered by means of the steering wheel that moves the rudders. In case of need and/or when in confined waters, manoeuvre the yacht by using the engines (changing the rpm and reversing the engine direction of rotation).

Keep in mind that the rudders effect is proportional to the propellers rpm and to the yacht fresh way, especially with headway; as a result of a high rpm and a high speed, the rudder efficiency is high, while when the engines are idling, with low fresh way, the reaction of the tiller angle is almost negligible.



WARNING

Before unmooring disconnect the electric cable for shore electric power supply.



CAUTION

It is the Owner's/the operators' responsibility to make sure that the mooring ropes, the towing rope, the anchor chain, the anchor line and the anchor are suitable for the intended use of the yacht, i.e. the resistance of the ropes or chains must not exceed 80% of the resistance to breaking of the relevant strength point.

11.6.2 Mooring manoeuvre

Before returning to port, stop in open water and test the inverters and thruster. Also check:

- The mooring lines and fenders must be ready for use;
- That the mooring berth and the berthing course are free from incoming, leaving or moored yachts or yachts with the signal of unsteered craft at shore;
- Check that on the main electrical panel, all necessary uses are supplied. Disconnect unnecessary uses;
- That interceptors are lifted;
- That the yacht hook is easily accessible and does not hinder any passage;
- Check the operation of the audible warning devices and the adjustable searchlight;
- In case of at-night mooring, have a torch light (possibly operating) handy;
- That the passengers will not interfere with operations and, if participating, they know whom to listen to and what to do;
- That bilge and black water tanks are empty;
- That mooring ropes and fenders are correctly arranged.

If the yacht is moored with the stern towards the shore, tug on the stern lines and on the deadweight until it approaches the shore.

If the yacht is moored side on, tug on the bow and stern lines so as to approach parallel to the shore.

Once moored:

- Stop the engines;
- Ensure that indication lights on the helm position are OFF and remove the start keys;
- Turn OFF any unnecessary electrical utilities and check the general configuration of the electrical panel and the indications of the multimeter;
- Check the proper operation of the bilge pumps;
- Check bilge and dry it;
- Rinse the yacht with fresh water;
- Connect dock electric power supply.

Before leaving the yacht, check following:

- Lower deck lights are not powered;
- Ensure that navigation lights and external lights are not powered;
- Ensure that the anchor light is powered;
- Ensure that unnecessary devices are not powered;
- Ensure that devices in use are powered; (bilge pumps);
- Ensure that the dock plug is properly connected and the cable cannot be damaged;
- Disconnect battery breakers;
- Make sure that the devices (life jackets, yacht hook, torches, etc..) are in their correct positions;
- Ensure that all bottles and containers with flammable liquids are properly sealed;
- Make sure that no food residues are left around (they could rot or clog scuppers etc..);
- Ensure that mooring is correct (in case of bad weather conditions, tighten the mooring lines as much as possible and check the distance from other yachts is appropriate; ensure fenders are properly fastened, etc..);
- Ensure that sea water intakes are closed;
- That lower deck compartments are properly closed;
- Ensure that engine compartment hatch is closed.

11.6.3 Mooring without people on board

If the yacht is moored and left unguarded, operate as follows:

- Close sea cocks and overboard drain valves of sea water circuits.
- Check the condition of the electrical panel and disconnect all unnecessary uses.
- Ensure that all portholes and hatches are closed in all areas on board.
- Ensure that the mooring is in appropriate safety conditions.
- Ensure that the bilges are clean.
- Check that the waste water tank is empty.
- Ensure that the fuel suction lines are shut OFF.



CAUTION

The electric power supply from dock must be disconnected, especially if the yacht is left unguarded for a long period. It is necessary to recharge the batteries periodically. Overboard outlets and drain pipes should be regularly checked, in order to ensure good buoyancy. The electric system should be regularly checked, in order to prevent fires on board.



CAUTION

Inform the harbour arrangement manager of the on-board fire extinguishing system.



CAUTION

Disable the yacht's autoclave.

11.7 OPERATION AND PRECAUTIONS AT SEA

- During navigation do not unlock the chain stopper because you can seriously damage the yacht bow.
- Maintain a safe speed for the sea conditions, visibility, and when near other yachts.
- Do not exceed speed limits in harbour and confined waters.
- Follow all navigation rules applicable to the waters in which you are operating.
- Obtain plastic laminate reference cards for the Navigation Regulations and keep them handy on the helm position.
- Consult charts for information on locations of reefs, rocks, shoals, or other hazards to make sure that the yacht is not at risk of grounding or collision with fixed or floating structures.
- Frequently check that your route ahead and around the yacht is unobstructed (no yachts or objects in the expected route or approaching your yacht).
- Frequently confirm the yacht's position as you cruise, using all available aids, such as charts, visual observations and bearings.
- Before night navigation, make sure that navigation lights and search lights are operational. Ensure that the correct navigation lights are turned on for operation at night. Do not keep the anchor riding light on while the yacht is navigating.

- Use navigation lights in all conditions of reduced visibility, such as fog and rain and at all times between sunset and sunrise.



WARNING

When navigating at night, visual sharpness is crucial for a safe passage. To avoid collisions, reduce speed at night to compensate for limitations of visibility. Avoid switching on inner lights that may affect the captain's night vision.

- Know the characteristics of the sea bottom prior to anchoring. Keep well clear of other anchored yachts.
- During anchoring, pay special attention to avoid the rotating parts of the winch and take precautions when handling the anchor chain as it comes off the winch. Caution is needed to avoid injury to hands and fingers. Pay attention to ensure that your feet and legs do not get caught in the anchor rod.
- While the yacht is navigating, all persons on board must be seated in the designated seating areas in order to prevent injury due to falls caused by yacht movements with rough sea and in active wake areas or in the event of sudden changes in yacht speed or during manoeuvring. No one must be in the aft area when the yacht is under way.



WARNING

For comfort and safety, reduce the speed in the presence of waves.

**WARNING**

Persons entering the engine compartment when the yacht is navigating should be aware of the hazards of the yacht's motion and their potential exposure to high ambient temperatures, hot equipment components and operating machinery within the engine compartment.

Prior to entering the engine compartment, set the yacht on the most comfortable heading for sea and wind conditions. Persons in the engine compartment should maintain communication with the Captain.

**CAUTION**

To avoid heavy injuries or even death caused by hazards in the engine compartment, avoid the contact with hot and/or moving parts, while you are working in this area, wear proper safety clothing and also safety goggles and safety gloves. Be very careful around hot or moving parts. Wear hearing protection if the engines are running.

**DANGER**

It is forbidden to carry out sudden manoeuvres at high speed. This can result in accidents to persons on board.

**DANGER**

It is forbidden to stand or sit in the bow area during navigation.

**DANGER**

It is absolutely forbidden to perform reverse run with one of the two engines stopped. This operation is allowed only in case of endangering life for the persons on board and for the safety of the yacht itself, however when the engine is running it should not run higher than 1000 rpm.

Observing the following guidelines will improve comfort, minimize noise inside the yacht, avoid damage and assist in the proper operation of the yacht.

- Do not run the engines at idle longer than necessary.
- Avoid sudden accelerations and decelerations, which create stress on engine turbochargers.
- Run at idle for a few minutes before shutting down the engines, to allow a gradual cool-down.
- Once the yacht is at cruising speed, the engine instrumentation readings should remain steady. However, if, during normal operating conditions, the engine gauges show abnormal or contradicting values, investigate for possible systems and/or equipment problems or failures (stop the engines).
- Monitor the control panel gauges and system condition alerts frequently.
- Once in open waters and well clear of other yachts, increase the engine rpm gradually, until the desired speed is reached. Adjust the interceptor positions for the best performance.
- Adjust the speed to accommodate sea conditions.
- Check the engine exhausts. Very black smoke means in particular dirty filters or unburned fuel, due to improper calibration of injection pumps or injectors. Very white smoke may mean presence of water in the fuel. Bluish smoke may mean abnormal oil combustion.
- In case of abnormal vibration, reduce speed and run at slow rpm until the cause of the vibration is determined. If the vibration is severe, take the engines out of gear. It may be necessary to check the propeller condition. It may also be necessary to have a specialist check the propeller shaft alignment.

- Perform a visual inspection of the bilges periodically.

For the supply of fuel to consider the distance that we intend to cover.



WARNING

While the yacht is underway, all persons on board must be seated in the designated seating areas in order to prevent injury due to falls caused by sudden yacht movements in active wake areas or in the event of sudden changes in yacht speed or during manoeuvring. No one should be seated on the stern platform or on the bow area when the yacht is navigating.

11.8 SUGGESTIONS FOR NAVIGATION UNDER SPECIAL CONDITIONS

11.8.1 Navigation with bad weather conditions

It is very important during navigation in harsh weather, to make sure that all pieces of furniture, hatches, and mobile parts, are duly fastened or stowed, to avoid damages and above all to avoid hurting persons on board.

The reliability of machinery assumes even greater importance in adverse weather conditions.

The following table shows the maximum speed allowed in function of the wave height, in order to safeguard the yacht structural integrity.

Speed (knots)	Wave height in metres
10	0,59
11	0,52
12	0,46
13	0,42
14	0,38
15	0,35
16	0,32
17	0,29
18	0,27
19	0,26
20	0,24
21	0,22
22	0,21
23	0,20

Speed (knots)	Wave height in metres
24	0,19
25	0,18
26	0,18
27	0,17
28	0,16
29	0,16
30	0,15
31	0,14
32	0,14
33	0,13
34	0,12
35	0,12
36	0,11
37	0,10



WARNING

RIVA declines all responsibility for the improper use of the yacht, in relation to the wave height conditions.



WARNING

Before undertaking navigation, it is necessary to be aware of the sea and weather conditions you will find along the transfer route and in the area you want to reach.

Beaufort Scale	Descriptive Term	Wind speed		Probable wave Height (metres)	
		m/sec	knots	average	max
0	Calm	0 - 0,2	fino a 1	-	-
1	Light air	0,3 - 1,5	1 - 3	0,1	0,1
2	Light breeze	1,6 - 3,3	4 - 6	0,2	0,3
3	Gentle breeze	3,4 - 5,4	7 - 10	0,6	1,0
4	Moderate wind	5,5 - 7,9	11 - 16	1,0	1,5
5	Gentle wind	8,0 - 10,7	17 - 21	2,0	2,5
6	Fresh wind	10,8 - 13,8	22 - 27	3,0	4,0
7	Strong wind	13,9 - 17,1	28 - 33	4,0	5,5
8	Gale	17,2 - 20,7	34 - 40	5,5	7,5
9	Strong gale	20,8 - 24,4	41 - 47	7,0	10,0
10	Storm	24,5 - 28,4	48 - 55	9,0	12,5
11	Violent storm	28,5 - 32,6	56 - 63	11,5	16,0
12	Hurricane	over 32,7	over 64	14,0	

11.8.2 Navigation with one only engine

The yacht is driven by two powerful propulsion systems designed to operate together and at the same time.

In case of failure of one of the propulsion systems, you may navigate with only one engine.

In this case, we recommend that you:

- Shut OFF the failed propulsion engine;
- Set the position of the steering wheels in the opposite direction of the failed propulsion system; in case the steering wheels cannot contrast the asymmetric push of the operating system, lower the interceptor on the side of the failed system, or reduce the speed;
- Head to the nearest landing at a reduced speed;
- Keep the yacht at a speed that allows you the best manoeuvrability.

In case one engine stops due to a failure and the gear box is in idle position, during navigation keep a constant eye on the oil temperature of the gear box connected with the failed system.

The propeller shaft is kept rotating thanks to the water flow through the propeller; under these conditions some parts of the gear box are also kept rotating.

Should the temperature increases excessively over 80°C (176°F), lock the propeller shaft by engaging the gear box: in this way the resistance will be higher, because the gear box is jammed, but oil will not overheat.



WARNING

The yacht has been designed to navigate driven by two engines; please remember that it is possible to navigate with one engine only in case of emergency and for a very short time.



DANGER

It is absolutely forbidden to perform reverse run with one of the two engines stopped. This operation is allowed only in case of life danger for the persons on board and for the safety of the yacht itself; however when the engine is running it should not run higher than 1000 rpm.

11.9 TOWING THE YACHT

In case the yacht needs to be drawn or towed, fasten the towing lines as shown in the figure, in order to distribute the load evenly and pull in the middle.

The towing rope length depends on the sea conditions, and must be adjusted in such a way to limit the pulling forces without damaging the deck fittings.



WARNING

During towing, keep a constant eye on the water temperature, the oil pressure of the propulsion engines and maintain a suitable speed for the type of operation.



DANGER

Do not approach and do not carry out any kind of intervention on transmission during the towing because propeller can turn.



**WARNING**

In case it is necessary to tow another yacht, do this under calm sea and calm wind conditions only, and tow ship with a displacement not exceeding 50% of your ship displacement; in case of emergency, if towing is not possible, give help by taking on board people of the other ship, as many as permitted and possible, and reach the nearest harbour. Anyway, inform immediately the Port Authority.

**WARNING**

Towing navigation can be carried out continuously for 8 hours, provided that you constantly monitor the gear box oil temperature, which must not exceed 80°C (176°F).
If temperature exceeds 80°C (176°F), stop navigation and wait until the temperature lowers.
When the engine is shut off, the throttle position is unimportant.

**CAUTION**

Always draw other boats or let your yacht be towed at low speed. Never exceed the speed of the drawing yacht when you are being towed.

**CAUTION**

Fasten your yacht to a towing rope so that it can be released when loaded.

**CAUTION**

It is the Owner's/operators' responsibility to make sure that the mooring ropes, the towing ropes, the anchor chain, the anchor line and the anchor are suitable for the intended use of the yacht, i.e., the resistance of the ropes or chain must not exceed 80% of the resistance to breaking of the relevant strength point.
The Owner should also determine which action is necessary when fastening a towing rope on board.

**CAUTION**

Do not stand near the ropes during drawing (or towing) operations, a rope that breaks can be extremely dangerous ("whip lash effect").

**DANGER**

During towing navigation, the propeller shaft has to be kept turning by the water flow through propeller. We recommend not carrying out any kind of service on the propulsion devices (engines, gear boxes, shafts, etc..).

11.10 YACHT STEERING RULES

Ship in sight

We can consider three ways of encountering another yacht on the water:

- Meeting;
- Crossing;
- Overtaking.

Normally, the yacht with less manoeuvrability has the right-of-way.

Stay clear of the yacht and pass to its stern. The yacht, that has the right-of-way, is called the “privileged yacht”. This yacht can maintain speed and course. The “burdened yacht” is the yacht, which must adjust her course and/or speed as required to keep clear of the privileged yacht.

Meeting

When meeting another yacht proceeding on a parallel course, both yachts shall adjust the speed accordingly and keep on course.

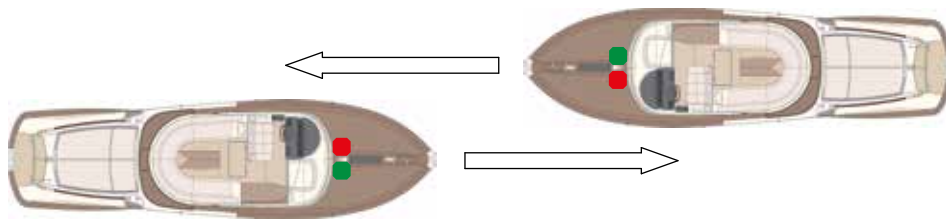

When two power-driven yachts are meeting on reciprocal or nearly reciprocal courses so as to involve risk of collision each shall alter its course to starboard so that each shall pass on the port side of the other.

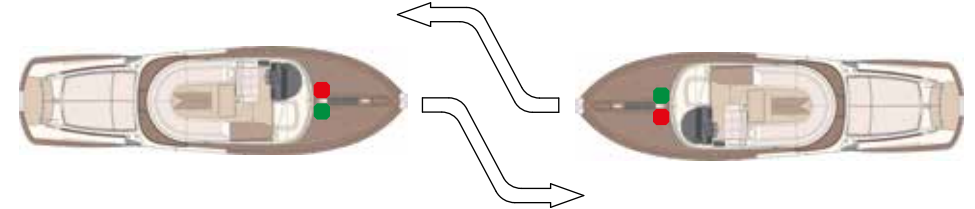

Crossing situation

When two power driven yachts are crossing so as to involve risk of collision, the yacht which has the other on its own starboard side shall keep out of the way and shall, if the circumstances of the case admit, avoid crossing ahead of the other yacht.

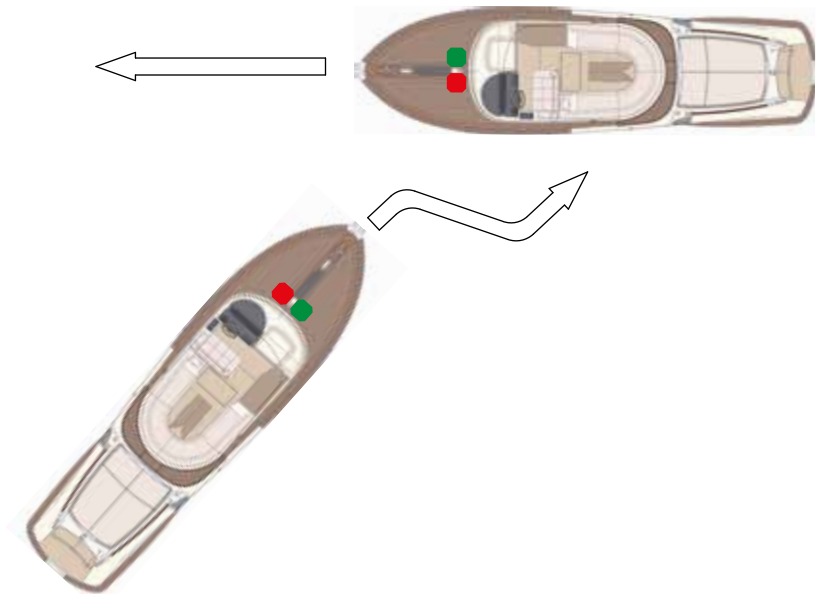

Overtaking situation

An overtake is defined as when one yacht comes from a direction of over 22.5 degrees aft, with respect to the yacht that it intends to overtake, in order that the stern lights can be seen but none of the side lights.

If you find yourselves overtaking a slower yacht, which is in your path, you are the burdened yacht. Make any adjustment necessary to avoid collision and pass either to port or starboard. Signal your intent to do so by sounding your horn twice if passing on the port and once if passing on the starboard.

The yacht being overtaken by another, takes precedence over the latter and thus must maintain the same route and the same speed no pull or manoeuvre.

The yacht that has the bow within a 135° angle (formed by the yacht stern light) is considered the yacht that can be reached.

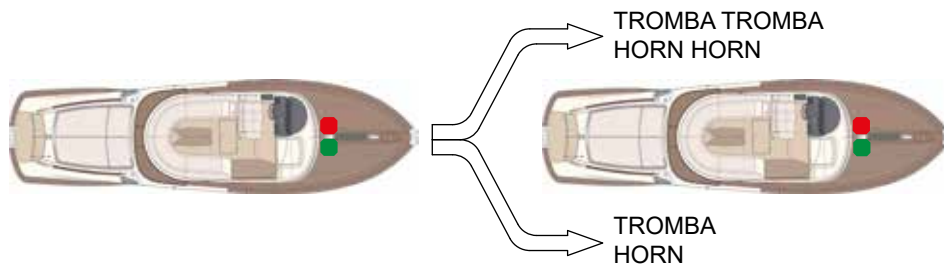

CAUTION

Having the right of course does not relieve you from the responsibility of avoiding a collision.

Responsibility between yachts

It is necessary to observe the following regulations, except when in conflict with other rules:

Mechanically propelled yachts, when underway, should keep the course clear for:

- Boats that are unable to steer.
- Boats with limited manoeuvrability.
- Boats engaged in fishing.
- Sailing boats.

Boats engaged in fishing, when underway, should keep the course as clear as possible for:

- Boats that are unable to steer.
- Boats with limited manoeuvrability.



CAUTION

Boats with limited manoeuvrability generally have the right of way. In the event of an impending collision, prudence shall take precedence over the right of way.

11.11 PREPARATION FOR ANCHORING



CAUTION

If the anchor has to be used, unlock it, check the wildcats clutch engagement and test the operation of the anchor winch from the helm position in use.

We remind you that the anchor winch system has no end stroke safety controls, therefore we suggest you to handle “manually” the last chain metres, by means of the apparatus positioned in the bow windlass locker, when this is near the hawsehole or when it is calculated to wind almost the entire chain.

To avoid overheating of the anchor winch, it is advisable to help recovering it, by moving slowly the yacht toward the chain, without approaching it too closely, so as not to damage the hull.

If you weigh the chain after an anchoring on a muddy or weedy sea bottom, we suggest washing it during the weighing, using the button on the helm position.

11.12 HAULING AND LAUNCHING

Preliminary operations

Before proceeding with the operations for launching or hauling, check:

- No one is on board;
- There are no objects free to move;
- All doors and hatches are closed;
- All on-board equipment is disconnected and the possibility of activation is prevented.



DANGER

Hauling and launching operations must only be carried out by specialised personnel.

The yacht is equipped with 4 fixing points for hauling and launching. The fixing points are rings located in the engine compartment behind the engines (no.2) and in the bilge under the cockpit (no.2).

Always use the attachment points to lift the yacht; if you must use the hull straps (not recommended), do not place them on the axles or rudders. Use a spacer to keep the straps at an angle greater than the beam of the hull.



CAUTION

Bleed the mechanical seals each time the yacht is hauled/launched.

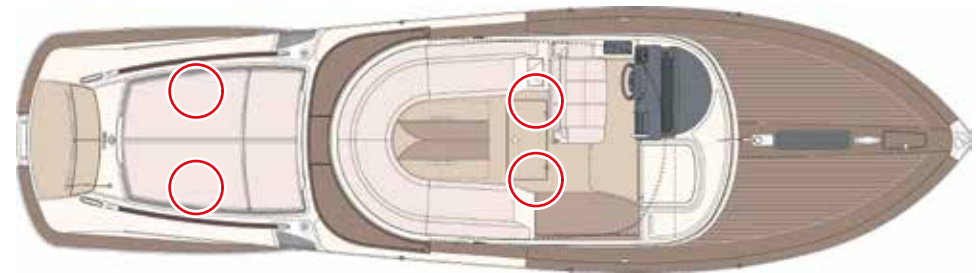



CAUTION

Always check the balance and stability of the yacht when lifting.



CAUTION

The lifting belts must be connected to the designated points; check that the belts are not folded or twisted.
Lifting hooks should be tight; lifting should be carried out gradually.

Lifting the yacht:

Before lifting, check the yacht's stability: the centre of gravity of the yacht depends on the loads and their position on board.



CAUTION

The lifting equipment used must be in good condition.
Lifting belts must not show wear.

When on the ground, the yacht must be positioned on supports of sufficient number and position to fully support its weight.
The inclination of the hull must be as "natural" as possible: this is to allow the on-board liquids to maintain a normal level and for rainwater to be properly discharged.



CAUTION

RIVA declines all liability for damage to property or persons if the operations are not carried out as described.
RIVA declines all liability for the position of the lifting bands, the support on the ground of the yacht and the positioning of the support points if carried out by third parties.



DANGER

Never stand near or below the yacht during hauling and launching operations.

Riva

AQUARRIVA *special*

Riva

AQUARRIVA *special*

HULL AND FURNITURE MAINTENANCE

CHAPTER 12

12.1 GENERAL MAINTENANCE OUTLINES

The yacht is equipped with a large number of sophisticated devices and systems, which require not only a certain care when it comes to use, but also regular maintenance to obtain correct operation.

One of the factors that might cause problems or faults, is usually the irregular use of the yacht and because of this, of the on-board devices.

Daily checks and regular maintenance are important for maintaining equipment/components in the best working order and efficiency.

If the regular maintenance schedule is not correctly followed, the equipment's performance can deteriorate, causing reduced efficiency, a shorter life and the occurrence of unexpected problems which can compromise safety at sea.

The maintenance schedule is based on time intervals or running hours.

In case of a long period of inactivity (for example, during winter), it is advisable to lay up the yacht, possibly under cover.



CAUTION

Some general information about ordinary maintenance tasks, their schedule and procedures is provided herein with.

For further specific information referring to maintenance schedule, see Manufacturer Manuals of on board devices/components, issued by the various Manufacturers.



CAUTION

Look over the maintenance safety rules contained in this manual in order to act with the maximum safety and follow the indications here below.



CAUTION

During the replacements, remove the parts with care and order, in this way the assembly operations are as easy as possible.

Make sure to install genuine spare parts, in this way the system efficiency is not altered.

Sometimes the use of non-genuine spare parts may cause the withdrawal of the Manufacturer's warranty.

**CAUTION**

Check periodically that all equipment containing water is filled with the correct quantity of anti-freeze.

If the outside temperature drops below 0°C, all water systems are exposed to the risk of freezing and consequent breakage.

Systems especially subject to risks of freezing are all systems and devices containing either fresh or sea water.

**WARNING**

Before carrying out any maintenance and adjustment operation on the yacht, turn all necessary safety devices on and consider informing all personnel, in particular persons operating nearby. In particular, place warning signs in the areas concerned and prevent any device, if operated, from causing unexpected hazardous conditions, thus endangering the persons on board and/or property.

To avoid pollution, do not scatter any type of waste in the environment, and only use the dedicated disposal areas in the harbours.

**CAUTION**

When working in the engine compartment, switch magneto-thermal switches of the bilge draining pumps OFF, to prevent that fuel, lubricants and other liquid spilling causes sea pollution.

**CAUTION**

RIVA declines all responsibility for the installation and operation of electric, electronic or mechanical equipment improperly installed by third parties in a manner not authorised by the Shipyard.

RIVA declines all responsibility with regard to tampering carried out by third parties on equipment installed in the Shipyard. Such tampering or unauthorized installations will not only immediately void the warranty, it may also cause damage to the yacht and injuries to the people on board. RIVA declines all responsibility concerning regular maintenance operations scheduled by the Shipyard or by Manufacturers, but not carried out, on equipment/components, for which it is necessary to refer to the relevant Technical Manuals.

12.2 LONG PERIODS OF YACHT INACTIVITY

Following list only represents a general guide to give the customer an idea of the ordinary maintenances which should be carried out when the yacht remains stationary for a rather long period without being used.

We recommend carefully checking the instruction manuals of the single devices, because they often contain detailed information and very important specifications relevant to the maintenance of each device.

The following instructions NEVER REPLACE the specific instructions concerning each single device and issued by the device's Manufacturer.

- **Engines**

Before winter time let fresh water flow into the sea water circuit, check the antifreeze liquid, the sacrificial anodes against the galvanic currents, remove salt build-ups and spray protective agents.

Carry out the scheduled maintenance of the propulsion engines, indicated in the Use and Maintenance section.

- **Gear boxes**

Carry out the scheduled maintenance for gear boxes.

- **Batteries**

Check the liquid level and regularly charge the batteries, protect the terminals with Vaseline grease; the best solution would be to disconnect the batteries from the system and to charge them regularly with a separate battery charger, but this is not always possible on yachts.

- **Sun-deck cushions**

Remove all cushions and store them in a dry and ventilated place.

- **Aluminium and steel**

Wash all metallic parts with fresh water and protect by rubbing with a rag soaked into Vaseline oil.

- **Wood and interior upholstery**

Cover the cushions of sofas with sheets and above all cover all windows with the relevant covering sheets, so that as little light as possible is projected inside, because the UV-rays fade the wood and tissue colours.

- **Main deck**

Wash with water and neutral soap and treat with proper products. Sandpaper if strictly necessary.



CAUTION

DO NOT USE mechanical or forced water jet equipment (e.g. pressure washers, etc..) to wash the deck, as this force alters the wood and the caulking sealants (it detaches the microparticles) causing damage in some cases even radical (e.g. detachment of the staves).



CAUTION

DO NOT USE alkaline-based or acid-based detergents or aggressive detergents (soda, solvents, ammonia, etc..) to wash the deck; their aggressive degreasing action corrodes the wood (it eliminates its natural water repellency and whitens its natural colour), while the caulking sealant modifies its physical-chemical qualities, softening the surface, damaging the waterproofing, sealing and anchoring of the deck.

- **Sacrificial anodes**

Check wear and if necessary replace the sacrificial anodes on the hull, propeller shaft and interceptors.

- **LOG Transducer**

Pull out the propeller, clean it and apply the proper propeller plug.

- **Windscreen wiper**

Wash with fresh water and lubricate with Vaseline oil.

- **Anchor winch**

Protect the electrical components with a suitable protective spray and lubricate with silicon grease clutch and Barbotin.

- **Black water tank**
Pour a sanitary product containing Paraformaldehyde into the WC and rinse the tank with this mix a couple of times. Drain the tank completely.
- **Bow thruster (optional)**
Protect the electrical components with a proper spray, check the oil level, and the sacrificial anode. If necessary, replace the anode.
- **Steering system**
Protect with the proper sprays and check the oil level.
- **Electro-hydraulic control units**
Protect with the proper sprays and check the oil level.
- **Fire extinguishers**
Check the loading condition and expiry date for regular inspections. Check also the correct positioning and preservation of every single extinguisher on board.
- **Safety equipment**
Check the correct positioning and the expiry dates of the self-inflatable means, flares etc..
- **Water tank**
Wash with disinfectant, drain the fresh water circuit, especially if frost is forecasted.
- **Fuel tank**
Cleaning by means of a decanter especially if there are traces of water in the fuel.
- **Engine compartment**
As for the engine compartment, we suggest carrying out a general cleaning, by removing all traces of salt drifts on devices and protect all electric, mechanic and hydraulic devices, by spraying them with protective agents.

General checks:

- Tidy the cabin, clean it and inspect all the on board wells.
- Check all hatches seals and lubricate their contact with appropriate silicone lubricant.
- Inspect the outer hull and all components: propeller, anodes, supports, interceptors, sea cocks, bow thruster.
- Carry out laying up of the yacht in a sheltered and dry place. If the yacht is stationed outside, cover it with a waterproof sheet, in such a way that allows ventilation. Otherwise the formation of damaging moisture could be helped.
- Wash the yacht with fresh water.
- Check all systems and fastenings on the yacht: damages, wear, cracks are signs of unsuitable use. Repair the damaged equipment. If necessary, fit new ones.
- Check the efficiency of limber holes and that they are not clogged so as to cause the leaking of the bilge system.
- Check the fastening of the partial or total covering of the yacht.
- Disconnect all unnecessary utilities.

**DANGER**

During recharge the batteries produce explosive gas. Do not approach to recharging area with free flames or sparkles.
Avoid wrong connections; never connect a positive terminal (+) with a negative one (-).

12.3 RE-USE OF THE YACHT AFTER A LONG INACTIVITY

Engines:

- After the winter, check engines oil, gear boxes and replace them if necessary. Check oil and fuel filters and replace them if necessary.
- Adjust the tension of the alternator belts of the propulsion engines.
- Fill the fuel tank. Vent the air of the fuel system.
- Start propulsion engines.



CAUTION

After a long period of yacht inactivity, carry out all above-listed operations and following checks:

- Check the condition of all hoses and connections of the steering system, interceptors, swim ladder, etc..
- Start the engines.
- Stop the engines.
- Clean fuel filters. Replace engine oil filters and add oil to the engines if necessary.
- Check all bilge pumps and their operation.
- Check the operation of the black water and sea water pumps.
- Check the operation of all on-board instruments used for navigation.

- Let the engine run at middle speed for some minutes, before letting them run at full speed.

Hull:

- Verify the hull.
- Have the bottom hull accurately cleaned, as well as the rudders and interceptors with brushes (with water) or a jet-cleaner (dry) to remove seaweed and scales.
- Check the paintwork condition of the hull. If necessary, have 2 coats of suitable antifouling paint applied by specialized personnel.



Propellers and anodes:

- Verify the propeller condition and possible leaks from the seals, if necessary adjust them.
- Check the conditions of the sacrificial anodes; if necessary, replace them.

Batteries:

- Check the charge of the batteries, and that their terminals and housings are dry and clean.

12.4 HULL MAINTENANCE

Problem	Cause	Corrective action
Bottom hull	Periodical cleaning and check of antifouling treatment (as required according to stationary area, but at least every three months)	<p>The length of the anti-fouling effects depends mainly on the conditions of the waters where the yacht is stationed.</p> <div style="border: 1px solid yellow; padding: 10px; text-align: center;">  <p>CAUTION</p> <p>When removing the old antifouling, do not use sandblasting methods, as this may damage the gel-coat surface and the anti-osmosis resin applied by the Manufacturer. As suggested by the antifouling manufacturers, use paint removers or, as an alternative, wet sanding.</p> </div>
	Check/restoration	<p>The Shipyard uses high-quality ant-fouling paint and applies two layers.</p>
	Preparation of the surface of an already treated yacht	<div style="border: 1px solid yellow; padding: 10px; text-align: center;">  <p>CAUTION</p> <p>Bad maintenance condition (barnacles, etc..) may cause cavitation and damage shaft, rudders, propellers, etc..</p> </div> <div style="border: 1px solid yellow; padding: 10px; text-align: center; margin-top: 10px;">  <p>CAUTION</p> <p>Small areas of paint may peel off from the propellers even after a short period of operation.</p> </div>

12.4.1 Bottom hull

Antifouling treatment

If scales builds up on the hull, this causes notable speed reduction and with time may damage the “gel-coat”. When you choose an antifouling paint for your yacht, it is important that you find the proper product, suitable for your yacht and for the waters in which you are going to navigate. Contact the RIVA After Sales & Service Department.

Check/restoration

The cleaning and checks have to be carried with yacht at dry shore or with the help of a diver. Have the repairs done only with yacht at dry shore.



WARNING

To clean or check the yacht in water, disable engines ignition.



CAUTION

There are some hull areas (fastening area of thrusters shaft support base, submerged drainage areas, around the thruster tunnel and shaft exits, etc.) where operations can be carried out after hull pressing; in these areas, fillers are usually used which, over time, may produce local faults, like bubbles or small cracklings. These little faults do not impair the hull’s mechanical strength at all. To repair them just sandpaper the area, remove the bubbles, and apply fillings suitable for the bottom hull.

- Have the bottom hull accurately cleaned, as well as the rudders and interceptors with brushes (water) or a jet-cleaner (dry) to remove seaweed and scale.
- Check the paintwork situation of the bottom hull. If necessary, have 2 coats of suitable antifouling paint applied by specialised personnel.

Preparation of the surface of an already treated yacht

Carefully check the old anti-fouling paint to see if it is still good or if it needs a new layer. Make sure that the new product is compatible with the old one. Contact the RIVA After Sales & Service Department. If the old antifouling is crusty, thick and tends to scale off, then remove it and start the treatment as for a new yacht.



CAUTION

Antifouling is poisonous and should never be burnt, use only authorized disposal procedures and in case of doubts contact the authorities in charge. The sandblasting operations and removal of antifouling must be carried out with suitable clothes and protections.







WARNING



During the application of antifouling, make sure that following parts of the bottom hull are not painted:

- Depth sounder transducer;
- LOG speed sensor propeller;
- Sacrificial anodes;
- Shafts and propellers.

12.5 GENERAL MAINTENANCE

Problem	Cause	Corrective action
<p>Gel-coat</p> <div data-bbox="165 408 533 775" style="border: 1px solid yellow; padding: 5px;">  <p>CAUTION The alteration of colour and brightness in areas which are highly exposed is considered normal. The necessary polishing has to be considered as normal maintenance.</p> </div> <div data-bbox="165 820 533 1225" style="border: 1px solid black; padding: 5px;"> <p>MAINTENANCE At least once a month carefully clean all fibreglass parts. At least once every six months check the status of the fibreglass. When necessary, but at least once every two years, polish all fibreglass parts.</p> </div>	<p>Formation of bubbles Regular cleaning (as required)</p> <p>Formation of cracks Regular cleaning (as required)</p>	<p>In some areas of the yacht, bubbles may form on the gel-coat; these bubbles can break over time, thus exposing the fibreglass underneath. The drawback occurs generally in vicinity sharp angles, and depends on air bubbles that, during fabrication, remain entrapped between fibreglass and gel-coat, although quality checks are carried out by specialised personnel. Broken gel-coat bubbles are easy to repair by filling the voids and touching up with gel-coat that can be requested from the RIVA After Sales & Service Department.</p> <div data-bbox="940 584 2136 775" style="border: 1px solid yellow; padding: 5px;">  <p>CAUTION Always wash using neutral products. In case of particularly persistent dirt, do not use products containing ammonia which can turn the surface yellowish.</p> </div> <p>When underway, some structural parts of the yacht are subject to bending, and create tension or compression stresses in fibreglass and on the gel-coat; the different elasticity of gel-coat and fibreglass can cause small cracks on the gel-coat surface, in particular in the most stressed areas, e.g., near cleats, stanchions, etc.. This problem, however, does not jeopardize the mechanical and structural characteristics of fibreglass.</p> <div data-bbox="940 1034 2136 1257" style="border: 1px solid yellow; padding: 5px;">  <p>CAUTION To remove gelcoat, do not use sandblasting methods that may damage the surface of the anti-osmosis resin applied and could expose fibres. As suggested by gel-coat Manufacturers, use suitable products or, as an alternative, wet sand.</p> </div>



Problem	Cause	Corrective action
Wood and upholstery	Regular cleaning	<p>The worst enemies of these materials are light and moisture; to protect them, they must be kept away from direct light as much as possible and the interior must be ventilated as soon as the weather conditions allow. The use of external awnings is extremely important because there is no species of wood, either natural or dyed, which, when exposed to the sun's rays, does not undergo a change in colour.</p> <p>The woods used for the yacht's fittings are exclusively natural-based materials carefully selected and the painting cycles with which they are treated comply with environmental regulations. Furniture made of wood, precisely because of the natural origin of both the material and the treatments, may be subject, if not properly treated and maintained, to:</p> <ul style="list-style-type: none"> • Colour variations due to exposure to direct and continuous light. It is advisable to shade the heavily exposed parts; • Retention of dirt if not cleaned promptly, given the characteristic absorbency of wood fibres. It is recommended to use non-aggressive products; • Scratches and marks if in contact with sharp or metallic objects, due to the inevitable relative "softness" of the wood. <p>Despite the painting cycles developed after many years of experience, wood remains a "living" material, and therefore subject to movement and settlement.</p> <p>Scratches caused by bumps must be repaired immediately, to avoid the blackening of the wood below. The technical staff of the RIVA After Sales & Service Department will advise you about the maintenance level you have to apply at the end of each season's use. Correct maintenance will allow you to avoid deterioration which is expensive to repair.</p> <div style="border: 2px solid yellow; padding: 10px; margin-top: 10px;"> <p style="text-align: center;"> CAUTION</p> <p>The extremely fine finish of glossy varnished woods is waterproof, but it is also delicate and requires proper maintenance. Such surfaces must therefore be dried after use or after rain and must be washed and maintained regularly.</p> </div>



Problem	Cause	Corrective action
Wood and upholstery	Regular cleaning	<div style="border: 2px solid yellow; padding: 10px; margin-bottom: 10px;">  CAUTION Upholstery and wooden parts: the leather and wooden parts have to be treated as natural products, subject to colour alteration, particularly if the necessary precautions for good maintenance are not taken. RIVA therefore reserves the right to evaluate any problems and its own responsibility according to case. </div> <div style="border: 1px solid gray; padding: 10px; margin-bottom: 10px; text-align: center;"> MAINTENANCE At least once a week, carefully wash and clean all teak outside parts, and at least once a year perform a protective treatment with suitable products. </div> <div style="border: 2px solid yellow; padding: 10px;">  CAUTION Current use: <ul style="list-style-type: none"> • Do not walk or jump on the cushions; • Prevent the cushions from turning yellow due to direct exposure to sunlight; • Prevent the absorption of water or moisture by not leaving the upholstery exposed to bad weather, particularly during periods of inactivity. Cleaning: <ul style="list-style-type: none"> • Remove ordinary dirt with a warm water solution and neutral soap: do not use detergents or solvents; • Dry with a soft rag, not leaving any residues. Preservation: <ul style="list-style-type: none"> • Store clean and dry upholstery in a cool, ventilated room with no moisture; • Do not place heavy objects on upholstery when stored. </div>

Problem	Cause	Corrective action
Teak	Regular cleaning	<p>The characteristic of teak is its resistance to weathering and therefore, it does not require maintenance. Over time, teak tends to assume a particular silver colour that may not appeal; in this case, to maintain the original colour of the teak, it needs to be treated regularly with specific products (e.g. teak wonder).</p> <p>If the wood has smears that cannot be removed with normal washing, it is necessary to sand the wood to remove stains, and then repaint with wonder teak.</p> <p>You must use fresh water and manual brush (no hard bristles) at least once a day. This will remove any machinery, common dirt from feet and shoes, and normal environmental salt. This process, if carried out regularly, allows constant maintenance of your teak and caulking. In this case only time and wear will naturally deteriorate this product.</p> <div data-bbox="878 683 2074 874" style="border: 2px solid yellow; padding: 10px; text-align: center;">  <p>CAUTION</p> <p>Do not clean the teak with stiff brushes, as even rubbing the grain lengthways can damage the softer grain of the wood.</p> </div> <p>Non-black caulking could have not the same behaviour compared with the black one, Any aesthetic issues like mildew on the surface, color variation, dirt in the caulking have not been addressed as defects and could be prevented with a regular maintenance and service of the mahogany surface and caulking.</p>
Leather cushions	Regular cleaning	<div data-bbox="878 1072 2074 1198" style="border: 2px solid gray; padding: 10px; text-align: center;"> <p>NOTE</p> <p>For correct cleaning and care of the leather cushions, refer to the use and maintenance document provided in the annex to this manual.</p> </div>

Problem	Cause	Corrective action
Ceilings Panels	Regularly check the flatness of the panels and / or any discontinuities or steps between the ceiling panels	<p>Whenever the ceilings are disassembled, it is compulsory to check the status of the Fit Lock or/ and 3M Dual Lock fastening systems, breakage of the teeth, and/ or the entire system.</p> <div style="border: 2px solid orange; padding: 10px; text-align: center;">  <p>WARNING</p> <p>Do not install Fit Lock or 3M Dual Lock ceiling panels with damaged fastening systems , due to a possible reduction of their retention power. Damaged parts must absolutely be replaced with new ones.</p> </div> <p>In order to be sure that the ceilings have been reassembled correctly, check flatness with the other ceiling panels and the absence of discontinuities and steps between one ceiling panel and the others.</p>

Problem	Cause	Corrective action
<p>Light alloys and stainless steel</p>	<p>Regular cleaning</p>	<p>It is a good rule to accurately wash the entire yacht after each navigation, in particular all metal parts that may be damaged by sea water. Have plenty of fresh water sprayed on handrail, windows, skylights, rub rail, anchors, cleats and ladder. Protect all metal parts with Vaseline oil periodically.</p> <div data-bbox="880 435 2076 523" style="border: 1px solid black; padding: 5px; text-align: center;"> <p>MAINTENANCE At least once a year check the fastening of all metallic parts of the yacht.</p> </div> <div data-bbox="880 568 2076 758" style="border: 2px solid yellow; padding: 10px; text-align: center;">  <p>CAUTION Never use brushes or abrasive rags on metallic fittings, not even on rusty spots, scratches on the surface result in a less shiny appearance and diminish the mechanical features.</p> </div>

Problem	Cause	Corrective action
Windscreen/windows	Regular cleaning	<div data-bbox="943 268 2136 496" style="border: 1px solid yellow; padding: 10px; margin-bottom: 10px;">  CAUTION Rags and chamois leathers used for cleaning glass must be replaced at least every 3 months. The inner side of windows and windscreen can be cleaned with non-aggressive and non-acid detergents for glass and a soft or paper cloth. </div> <div data-bbox="943 539 2136 767" style="border: 1px solid yellow; padding: 10px; margin-bottom: 10px;">  CAUTION If, after a normal cleaning, some traces of dirt or light scratches remain, do not try and remove them with mechanical means or using aggressive detergents, solvents or abrasive products. Contact RIVA After Sales & Service Department. </div> <div data-bbox="943 810 2136 1321" style="border: 1px solid yellow; padding: 10px;">  CAUTION For cleaning the outer side of windows and windscreen: <ul style="list-style-type: none"> • Evenly wet the whole surface of the glass with plenty of fresh water. • Use a neutral detergent or a delicate commercial product (not alkaline) diluted in fresh water. • Spread the solution with a soft and clean cloth. Frequently rinse the cloth in order to prevent deposits of dust or dirt particles which could scratch the glass or its glazed coating. • Rinse the soapy surface with plenty of fresh (or distilled) water. • We recommend drying the glass with chamois leather only. <p>For cleaning the windows and windscreen it is possible to use the same type of detergent used for internal cleaning (non-aggressive and non-acid).</p> </div>

Problem	Cause	Corrective action
Windscreen wiper and washer	Regular cleaning (as required)	Wash them carefully with fresh water and coat with Vaseline oil; grease the spring with silicone grease. Check the rubber blade conditions regularly, and replace the blades if worn; this prevents bad visibility problems.
Windscreen and deckhouse glass	Inspection of seals	<div style="border: 2px solid yellow; padding: 10px; text-align: center;">  <p>CAUTION</p> <p>At least once every 6 months check the condition of the glass seals. If you feel that the seals have deteriorated due to a wear, please contact RIVA After Sales & Service Department.</p> </div>
Light fittings	Regular cleaning	DO NOT use alcohol-based products to clean the light bodies.
Instrumentation and navigation lights	Regular cleaning (as required)	<p>Use clean wet rags for cleaning.</p> <div style="border: 2px solid black; padding: 10px; text-align: center;"> <p>MAINTENANCE</p> <p>At least once a week, check the operation of the navigation lights. At least once a week, carry out careful cleaning of glasses and headlights. At least once every six months, check the presence of corrosion in the connections of the navigation light cables. At least once every six months, tighten the cable connections of the navigation lights.</p> </div> <div style="border: 2px solid yellow; padding: 10px; text-align: center; margin-top: 10px;">  <p>CAUTION</p> <p>Do not use chemical or abrasive products.</p> </div> <p>After navigation, cover instrumentation and equipment.</p>

Problem	Cause	Corrective action
Metal parts and connectors	Regular cleaning (as required)	Grease connectors and metal parts of the devices installed and exposed to moist and salty environment to prevent oxidation; pay particular attention to the above-mentioned components of the steering system, control units, etc..
Fenders	Regular cleaning (as required)	Always keep all the fenders and their sleeves clean by washing regularly with fresh water, in order to prevent the salt deposited on them from scratching the paint of the hull.

12.6 MAINTENANCE AND CARE OF VARNISHED WOODEN PARTS

Wood is a natural material, and for this reason, its aesthetic characteristics may change over time and depending on climate conditions (surface shrinkage, changes in colour and dimensions, etc.). The natural origin of this material means that each product possesses unique features that enhance its handcrafted character.

Caring for the wood on your boat is an act of love and respect for your vessel. From old panels that tell stories to new surfaces ready for future adventures, looking after the wood is key to maintaining the timeless elegance of our RIVA yachts.

Below are some essential tips that RIVA considers fundamental for the correct maintenance of your yachts.

To preserve the beauty of our yachts, whether dealing with aged wood or brand new surfaces, it's essential to adopt a dedicated care regime.

The maintenance of these parts includes cleaning, inspecting for hidden damage, sanding, and applying protective varnishes or oils. Regular check-ups are important to keep the wood in excellent condition and extend its lifespan.

Let's go through the key steps for caring for wooden surfaces:

- **Regular cleaning of surfaces.**
Regular cleaning is essential to maintain the wood's appearance. Use gentle detergents, preferably those specifically made for marine surfaces, to remove dirt, dust, and salt deposits that can damage the wood over time. Do not use pressure washers or high-pressure tools. Always wash with fresh water only, using a soft brush or scrubbing brush. Brush across the grain to avoid scoring the surface, then dry with a soft, dry cloth.

- **Inspection of the condition of the varnish and repair of damaged areas.**
Carefully inspect the wood for any signs of damage such as cracks, scratches, grooves, or mould. If the surface is still in good condition, a simple clean and possibly a light touch-up with a clear protective varnish will suffice.

If, on the other hand, the varnish is damaged or deteriorated, follow these steps:

1. **Sanding:** Use fine sandpaper to remove damaged areas and even out the surface;
2. **Cleaning:** After sanding, remove dust with a damp cloth or compressed air;
3. **Varnish application:** Varnishing is one of the most important steps in wood care. Apply even coats of high-quality marine varnish. Consider using polyurethane-based products for better durability and resistance to the elements, or choose exterior-grade varnish (e.g., water-based enamels or specific synthetic varnishes);
4. **Clear coat application:** After applying coloured or protective varnish (except on decks with maple inlays), apply a layer of clear coat. This layer serves to protect the underlying varnish from external elements such as moisture, UV rays, and temperature fluctuations, helping to prevent damage or fading. It also adds a glossy or satin finish to enhance the appearance.
5. **Drying and curing:** Allow each layer of varnish and clear coat to dry fully, according to the manufacturer's recommended times. Proper curing is crucial for achieving optimal hardness and long-lasting protection.

- **Inspection of the condition of silicone seals and repair of damaged areas.**

Deterioration of silicone (sealants) used on wooden parts of the boat can compromise the integrity of joints and cause water ingress, potentially damaging the wood. Here are some signs that indicate a deterioration of the silicone surface or sealed joints:

- Visible cracks or fissures;
- Warping or shrinkage;
- Colour no longer shiny and uniform but faded or opaque;
- Loss of elasticity;
- Accumulation of mould or algae;
- Water infiltration near sealed areas;
- Roughness or dustiness.

If one or more of these signs is present, remove the old silicone and replace it with a new layer of sealant. Ensure the surface is thoroughly cleaned before reapplying to guarantee good adhesion and prevent future leaks.

Timely replacement of silicone is important for maintaining the boat's integrity and protecting the wood from moisture damage.

- **Protection and precautions**

- Remove dirt, algae and salt with fresh water and a soft brush to prevent damage and deterioration;
- Regularly inspect wooden surfaces to identify and address any problems promptly, preventing more serious damage from occurring;
- Check that the silicone seals are uniform and that there are no cracks or degradation on the surface or in the joints;
- Avoid prolonged exposure to standing water;
- During the winter period or when the boat is not in use, use protective covers to reduce the exposure of the wood to the elements and temperature changes.

Summary table of operations:

Operation	Frequency	Description
Regular cleaning of the wood surface	At each use	Remove dirt, algae and salt with fresh water and a soft brush to prevent damage and deterioration.
Check for cracks or deformations	Quarterly	Regularly inspect the wood for cracks or deformations that could compromise the safety or durability of the wood.
Inspection of the varnish and finish	Quarterly	Check for damage or wear to the varnish and finish. Sand and reapply varnish as needed.
Checking the condition of the silicone seals	Every six months	Check that the silicone seals are uniform and that there are no cracks or degradation on the surface or in the joints.

Any restoration work on the boat must be carried out exclusively by authorised RIVA After Sales & Service Department using trained personnel.

Following the above recommendations is essential for maintaining the basic condition of the vessel and for upholding the boat's warranty.

12.7 SPEED MULTISENSOR (LOG) MAINTENANCE

Problem	Cause	Corrective action
LOG - speed multisensor with valve	Regular check - Ordinary Maintenance	<p>As indicated in the Manufacturer's manual.</p> <div style="border: 1px solid black; padding: 5px;"> <p style="text-align: center;">MAINTENANCE</p> <p>At least once every six months check the correct operation. At least once every six months check the connection of the cables. At least once every six months check the propeller and grease the outer Log.</p> </div>



Riva

AQUARRIVA *special*

Riva

AQUARRIVA *special*

TROUBLESHOOTING

CHAPTER 13

13.1 GENERAL NOTES

The yacht is equipped with a large number of complex devices and installations.

These require regular checks and maintenance to keep their operation correct.

One of the factors that might lead to problems or faults, is usually the irregular use of the yacht and, as a consequence of this, of the on-board devices.

In order to analyse a malfunction it is appropriate to ask the following questions:

- Is the malfunction caused by a human error?
- Is the malfunction due to bad weather conditions?
- Is the malfunction due to a device failure or to a fault of another external device, but in some way connected to the first one?
- At what stage does the malfunction occur: at the start, at steady state, at device switch OFF?
- Does the malfunction occur repeatedly; if yes in which way?
- What does the malfunction imply from an operating point of view?
- Does the malfunction trigger any signals (luminous and/ or acoustic: sirens, buzzers, etc..) and/or messages on a display and/or anomalous noises (like whistles, beats, buzzes, etc..) and/or anomalous smells (burning smell)?
- Does the malfunction interfere with the operation of other devices?
- Is the malfunction a real apparent fault (that is, it can be cleared after a device reset and following switch ON)?

The best, most complete answer we can give to the previous questions, will give us a malfunction analysis.

This section of the Manual analyses the most likely causes, that may lead to the malfunctioning of a component of the main components/devices on board. For any possible analysed cause, a corrective action is advised, in order provide a solution to the problem that is as effective as possible.



WARNING

We recommend, in order to operate with peace of mind, in full safety, taking good note of the Safety Rules relevant to Maintenance described in the "SAFETY RULES".



WARNING

Corrective actions may only be carried out by specialised and authorised personnel.
RIVA declines all responsibility for proposed corrective actions carried out by unskilled personnel.



CAUTION

For more detailed information, please refer to the various Manufacturer's Service Departments or contact the RIVA After Sales & Service Department directly.

13.2 PROPULSION ENGINES

For further information, please contact RIVA After Sales & Service Department.

Problem	Cause	Corrective action
1. Engine does not turn when starter is actuated <ul style="list-style-type: none"> - Battery - Starter - Engine wiring - ECU Engine Control Unit - Engine - Start-interlock limit switch 	<ul style="list-style-type: none"> • Low or defective • Defective cable connections • Defective engine wiring or starter • Faulty • Loose plug-in connections • Gear locked (engine cannot start manually) • Limit switch not installed or defective • Defective wiring 	<ul style="list-style-type: none"> • Charge or replace (see Manufacturer's documentation) • Check that cable connections are properly secured (see Manufacturer's documentation) • Check that cable connections are properly secured, contact Service • Contact Service Department • Check plug-in connections • Contact Service Department • Check limit switch • Check wiring
2. Engine turns but does not fire <ul style="list-style-type: none"> - Starter - Engine wiring - Fuel system - ECU Engine Control Unit 	<ul style="list-style-type: none"> • Poor or defective starter rotation • Faulty • Not vented • Faulty 	<ul style="list-style-type: none"> • Charge or replace battery (see Manufacturer's documentation) • Contact Service Department • Check vent • Contact Service Department

Problem	Cause	Corrective action
<p>3. Engine fires unevenly</p> <ul style="list-style-type: none"> - Fuel injection equipment - Engine wiring - Fuel system - ECU Engine Control Unit 	<ul style="list-style-type: none"> • Defective injector • Faulty • Not vented • Faulty 	<ul style="list-style-type: none"> • Replace • Contact Service Department • Check vent • Contact Service Department
<p>4. Engine does not reach full-load speed</p> <ul style="list-style-type: none"> - Fuel supply - Air supply - Fuel injection equipment - Engine wiring - Yacht - Rudder - Propeller 	<ul style="list-style-type: none"> • Shut OFF • Fuel pre-filter clogged (water/fuel separator) • Fuel filter clogged • Air cleaner clogged • Defective injector • Defective injection pump • Faulty • Yacht too heavy • Yacht's trim position • Marine growths on hull, propeller shaft, propeller, rudder • Rudder position • After propeller replacement: propeller too small/large 	<ul style="list-style-type: none"> • Open shut-OFF valve before fuel pre-filter (water/fuel separator) • Replace • Replace • Check air cleaner clogging indicator • Replace • Replace • Contact Service Department • Check yacht's load condition, reduce load if necessary • Trim yacht • Trim yacht • Clean • Align rudder • Replace only with original spares

Problem	Cause	Corrective action
5. Engine speed not steady - Fuel injection equipment - Speed sensor - Fuel system - ECU Engine Control Unit	<ul style="list-style-type: none"> • Defective injector • Defective injection pump • Faulty • Not vented • Faulty 	<ul style="list-style-type: none"> • Replace • Replace • Contact Service Department • Vent • Contact Service Department
6. Charge-air temperature too high - Coolant - Intercooler - Engine	<ul style="list-style-type: none"> • Incorrect coolant concentration • Contaminated • Air intake temperature too high 	<ul style="list-style-type: none"> • Check coolant properties • Contact Service Department • Check fans and ventilation air supply
7. Charge air pressure too low - Air supply - Intercooler - Turbo charger exhaust	<ul style="list-style-type: none"> • Air cleaner clogged • Contaminated • Faulty 	<ul style="list-style-type: none"> • Check air cleaner clogging indicator • Contact Service Department • Contact Service Department
8. Coolant leaks from intercooler - Intercooler	<ul style="list-style-type: none"> • Leaking, major coolant discharge 	<ul style="list-style-type: none"> • Contact Service Department
9. Exhaust gas black - Air supply - Fuel injection equipment - Yacht	<ul style="list-style-type: none"> • Air cleaner clogged • Defective injector • Defective injection pump • Overload 	<ul style="list-style-type: none"> • Check air cleaner clogging indicator • Replace • Replace • Contact Service Department

Problem	Cause	Corrective action
<p>10. Exhaust gas blue</p> <ul style="list-style-type: none"> - Engine oil - Exhaust turbocharger, piston rings, cylinder liner 	<ul style="list-style-type: none"> • Too much oil in engine • Oil separator clogged • Faulty 	<ul style="list-style-type: none"> • Drain engine oil • Replace • Contact Service Department
<p>11. White exhaust gas</p> <ul style="list-style-type: none"> - Engine - Fuel system - Intercooler 	<ul style="list-style-type: none"> • Not at operating temperature • Water in fuel • Leaking 	<ul style="list-style-type: none"> • Run engine to reach operating temperature • Check fuel pre-filter (water/fuel separator filter) and drain pre-filter • Contact Service Department

13.3 GEAR BOX

For further information, please contact RIVA After Sales & Service Department.

Problem	Cause	Corrective action
1. Transmission oil temperature too high	<ul style="list-style-type: none"> • Insufficient water flows through oil heat exchanger • Drain sludge from oil cooler • Undefined range, clutch slipping 	<ul style="list-style-type: none"> • Increase water flow • Clean oil cooler • Adjust mechanism
2. Transmission oil temperature too low	<ul style="list-style-type: none"> • Excessive water flow through heater exchanger 	<ul style="list-style-type: none"> • Reduce water flow
3. Oil pressure upstream of oil cooler and filter too high (*)	<ul style="list-style-type: none"> • Clogged oil filter • Oil cooler dirty 	<ul style="list-style-type: none"> • Clean filter and drain off oil sludge • Clean oil side of oil cooler
4. No operating oil pressure (*)	<ul style="list-style-type: none"> • No oil in transmission • Wrong rotation direction at transmission input • Faulty display unit 	<ul style="list-style-type: none"> • Add oil • Use special transmission version • Remedy fault
5. Operating oil pressure too low (*)	<ul style="list-style-type: none"> • Oil viscosity too low • Incorrect oil pump ratio • Defective oil pump • Pressure relief valve leaking • Timeswitch for pressure modulation defective 	<ul style="list-style-type: none"> • Use a prescribed oil grade • Adjust oil pump ratio to suit engine operating speed range • Replace oil pump • Remedy the fault • See Manufacturer's documents

(*) see monitoring data.

Problem	Cause	Corrective action
6. Operating oil pressure too high (*)	<ul style="list-style-type: none"> Oil viscosity too high Incorrect oil pump ratio 	<ul style="list-style-type: none"> Use a prescribed oil grade Adjust oil pump ratio to suit engine operating speed range.
7. Drive interrupted between transmission input and transmission output; clutch not transmitting torque	<ul style="list-style-type: none"> Mechanical transmission actuation: incorrect shift angle Electrical transmission actuation: electrical system fault Defective solenoid valve Longitudinal valve stuck No operating oil pressure 	<ul style="list-style-type: none"> Adjust setting Remedy electrical system fault Replace Remedy fault See “No operating oil pressure” or “Oil pressure too low”
8. Drive between transmission input and transmission output cannot be interrupted; clutch does not disengage	<ul style="list-style-type: none"> For possible causes and remedial actions, see “clutch not transmitting torque” fault 	<ul style="list-style-type: none"> Use a prescribed oil grade Adjust oil pump ratio to suit engine operating speed range
9. Clutch slips at high engine speed	<ul style="list-style-type: none"> Operating oil pressure too low (*) 	<ul style="list-style-type: none"> See remedy for “Operating oil pressure too low”. If the fault cannot be remedied on board, proceed at reduced engine speed - so that the clutch does not slip - until repairs can be carried out. Avoid changes in direction or only change direction with the propeller almost at a standstill and with engine idle speed as low as possible
10. Oil level decreases rapidly (as indicated on the dipstick). See maintenance job “Oil level check”	<ul style="list-style-type: none"> Leaks on housing joints or oil lines, oil escaping from shaft seals Oil cooler leaking into cooling system 	<ul style="list-style-type: none"> Correct mechanical fault Remedy fault, replace oil cooler if necessary
11. Oil level increases. See maintenance job “Oil level check”	<ul style="list-style-type: none"> Water entering the oil circuit from the cooling system 	<ul style="list-style-type: none"> Correct mechanical fault

(*) see monitoring data.

Problem	Cause	Corrective action
12. Transmission is too loud at certain speed ranges	<ul style="list-style-type: none"> Torsional vibration resonance of propulsion system in engine idle speed range 	<ul style="list-style-type: none"> Avoid critical speed range. Use more suitable flexible coupling (see Manufacturer's document)
13. Transmission too loud at engine idle speed range	<ul style="list-style-type: none"> Torsional vibration resonance of propulsion system in engine idle speed range 	<ul style="list-style-type: none"> Increase engine idle speed range
14. Engine stalls following rapid change from "Ahead" to "Astern"	<ul style="list-style-type: none"> Engine idle speed too low Change in direction made too quickly or made at excessive craft speed 	<ul style="list-style-type: none"> Increase engine idle speed range Change direction (see Manufacturer's document)

If the fault cannot be remedied, the transmission lubricating oil supply is also at risk. Proceed at reduced speed only until repairs can be carried out.

13.4 BATTERY CHARGER

For further information, please contact RIVA After Sales & Service Department.

Problem	Cause	Corrective action
1. No output voltage from the charger	<ul style="list-style-type: none"> AC voltage not supplied 	<ul style="list-style-type: none"> Check installation Check fuse valve, replace if necessary
2. Battery charger does not operate	<ul style="list-style-type: none"> AC voltage not supplied Input voltage too low The battery charger will not operate below 160/80V 	<ul style="list-style-type: none"> Check installation The AC green LED should light up, if power is supplied Check fuses or circuit breakers Check the input voltage
3. The battery charger does not operate, while mains voltage is present	<ul style="list-style-type: none"> Mains frequency could be too high or too low The frequency must be within 35-66 Hz 	<ul style="list-style-type: none"> Check the input frequency Check
4. Batteries not fully charged	<ul style="list-style-type: none"> Charge current too low Current to load too high Charge time too short Battery temperature too low Defective battery (short circuit in cell) 	<ul style="list-style-type: none"> See "charge current too low" Decrease the battery load Replace the battery Use temperature sensor Replace the battery
5. Battery loses charge quickly	<ul style="list-style-type: none"> Battery capacity reduced because: <ul style="list-style-type: none"> - Wastage - Sulphating/stagnation 	<ul style="list-style-type: none"> Replace batteries Charge/discharge several times, this might help, otherwise replace batteries

Problem	Cause	Corrective action
6. Batteries are warm	<ul style="list-style-type: none">• Defective batteries (short circuit in cell)• Battery temperature too high• Charge voltage too high	<ul style="list-style-type: none">• Replace batteries• Use temperature sensor• Check the switches setting

13.5 USES

For further information, please contact RIVA After Sales & Service Department.

Problem	Cause	Corrective action
<p>1. A connected utility will not receive power supply</p>	<ul style="list-style-type: none"> • Power line fuses blown • Wiring disconnected • Connections oxidised maintenance 	<ul style="list-style-type: none"> • Check the line and replace the fuses • Check wiring connections • Check and carry out proper maintenance

13.6 FUEL SYSTEM

For further information, please contact RIVA After Sales & Service Department.

Problem	Cause	Corrective action
1. Irregular fuel supply to engines	<ul style="list-style-type: none">• Circuit valves closed or not fully open• Filters clogged	<ul style="list-style-type: none">• Check/Open• Clean

13.7 WASTE WATER DRAINING SYSTEM

For further information, please contact RIVA After Sales & Service Department.

Problem	Cause	Corrective action
<p>1. Improper drainage of the waste water tank</p>	<ul style="list-style-type: none"> • Circuit valves closed or not fully open • Lack of maintenance • Abnormal pump operation 	<ul style="list-style-type: none"> • Check/open • Carry out maintenance • Check

13.8 HOT/COLD FRESH WATER SYSTEM

For further information, please contact RIVA After Sales & Service Department.

Problem	Cause	Corrective action
1. No water to outlets	<ul style="list-style-type: none"> • Circuit valves closed or not fully open • Tanks empty • Pump not receiving electric power supply • Protection pump mode 	<ul style="list-style-type: none"> • Check/open • Fill the tanks and bleed the circuit • Check • Reset
2. Pump starts even with outlets closed	<ul style="list-style-type: none"> • Circuit leaking 	<ul style="list-style-type: none"> • Leakage remove
3. The pump gets continuously on/off	<ul style="list-style-type: none"> • The tank has no air inside the membrane 	<ul style="list-style-type: none"> • Contact the Service Department

13.9 BILGE PUMPS

For further information, please contact RIVA After Sales & Service Department.

Problem	Cause	Corrective action
1. Bilge pump does not run. No water pumped	<ul style="list-style-type: none"> • Wire connections • Blown fuse 	<ul style="list-style-type: none"> • Check wire connection integrity, make sure wire connections are not corroded • A visual check may not be enough, a slight pull on each wire will indicate if wires are still connected • Check to ensure that no wire joints are hanging down into the water • Check the correct fuse size (fuse size is printed on the side of the bilge pump) • If fuse size is correct, check the impeller through the inlet opening to be sure it is not jammed or stuck with debris
2. Repeated blown fuse	<ul style="list-style-type: none"> • Fuse rating or clogged impeller 	<ul style="list-style-type: none"> • Re-check fuse to verify compliance to pump specifications • Also examine impeller area and clean any obstructions
3. Pump runs without water output	<ul style="list-style-type: none"> • Airlocking/cavitating • Pump strainer and impeller area clogged with debris 	<ul style="list-style-type: none"> • Inspect and reposition hose for short vertical discharge • We suggest installing pump below water line to ensure sufficient water flow • Faulty or clogged check valve may add to pump air locking • Disconnect pump and clean outside of strainer, clean debris around impeller, and reattached and re-hook wiring

Problem	Cause	Corrective action
4. Pump shaft corroded	<ul style="list-style-type: none"> Electrolysis, cracked housing 	<ul style="list-style-type: none"> Inspect pump housing for cracks which can cause leakage into engine cavity causing corrosion Possible incorrect current running through wiring causing corrosion.
5. Pump stays on after water is pumped out	<ul style="list-style-type: none"> Wire connections may be incorrect, automatic pumps may have faulty circuit, possible electrical short 	<ul style="list-style-type: none"> On bilge pumps check for correct positive and negative battery connections
6. Nozzle breakage	<ul style="list-style-type: none"> Hose clamp fastened too tightly 	<ul style="list-style-type: none"> Suggest using plastic style hose clamp, do not use PVC hose
7. Pump impeller spins backward	<ul style="list-style-type: none"> Check wiring 	<ul style="list-style-type: none"> Switch wiring for correct polarity
8. Wires overheated, melted insulation	<ul style="list-style-type: none"> Incorrect fuse size, possible jammed impeller 	<ul style="list-style-type: none"> Inspect & clean impeller area of any debris Make sure that impeller is free to rotate Check to make certain correct fuse rating is installed REPLACE ALL DAMAGED WIRING

13.10 ELECTRO-HYDRAULIC STEERING SYSTEM

For further information, please contact RIVA After Sales & Service Department.

Problem	Cause	Corrective action
1. Air bubbles or foam in the system	<ul style="list-style-type: none"> • The oil level in the system is too low • Possible openings and little holes on the suction pipes or faulty pump seals, which allow air to penetrate 	<ul style="list-style-type: none"> • Check • Check
2. Lack of pressure in the system	<ul style="list-style-type: none"> • The pump does not deliver oil • Relief valve is not calibrated • Potential leakage 	<ul style="list-style-type: none"> • Check • Check • Check
3. Leaks from the seals	<ul style="list-style-type: none"> • Possible abrasive substances have entered into the oil circulation, damaging the pump's shaft • Seals are faulty, broken or mounted in a wrong way • Too hot oil 	<ul style="list-style-type: none"> • Check • Check • Check

13.11 BOW THRUSTER

For further information, please contact RIVA After Sales & Service Department.

Problem	Cause	Corrective action
1. The electric motor does not turn and the warning light on the control panel is OFF	<ul style="list-style-type: none"> No electric power supply 	<ul style="list-style-type: none"> Check that the main magneto-thermal switch has been activated Check the status of the fuses of the control and main current; if necessary, replace them Possible presence of a short circuit; check the cables
2. The electric motor does not turn and the warning light on the control panel is ON	<ul style="list-style-type: none"> Presence of a foreign body in the tunnel, which blocks the thruster 	<ul style="list-style-type: none"> Check and eliminate the cause of the block
3. The motor turns too slowly	<ul style="list-style-type: none"> The battery is insufficiently charged Poor brush contact Presence of seaweeds or fishing line stuck in the thruster 	<ul style="list-style-type: none"> Adequately charge the batteries Replace the blades Proceed to clean
4. The motor turns (too) quickly but there is no propulsion	<ul style="list-style-type: none"> The safety pin has broken due to the presence of an object in the tunnel 	<ul style="list-style-type: none"> Replace the safety pin and eliminate the cause of the block of the thruster

Riva

A FERRETTIGROUP BRAND