

Riva

OWNER'S MANUAL

102 CORSARO *supera*

Il presente manuale è stato realizzato in conformità a UNI EN ISO 10240.
Se ne vieta la riproduzione, anche parziale, senza la previa autorizzazione scritta di **FERRETTI SPA**.
Il presente manuale viene emesso da **FERRETTI SPA**.

Riva

A FERRETTIGROUP BRAND

Sede legale:

Via Irma Bandiera, 62
47841 Cattolica – Rimini – Italy
Tel. +39.0541.839611
Fax +39.0541.839625

Sede amministrativa:

Via Ansaldo, 7
47100 Forlì – Italy
Tel. +39.0543.474411
Fax +39.0543.782410
www.ferretti-yachts.com

www.riva-yachts.com
customerservices@riva-yachts.com

1 - FOREWORD		3.3 ESCAPE ROUTES	46
1.1 GENERAL INFORMATION	2	3.3.1 External areas forbidden during navigation, with restricted access.....	49
1.1.1 Introduction to using the manual.....	2	3.3.2 External areas accessible with care during navigation	49
1.1.2 Organization of the manual.....	2	3.4 ALARM DEVICES	53
1.2 MANUAL INTRODUCTION.....	3	3.4.2 Smoke detection control unit.....	54
1.3 SERVICE REQUEST PROCEDURE - WARRANTY.....	6	3.4.1 Alarm system for high water in the bilge.....	54
1.4 NOTICES	7	3.5 ENGINE ROOM FIRE-FIGHTING SYSTEM	57
1.5 SPECIFIC SAFETY WARNINGS	8	3.5.1 Fire-fighting system operation.....	60
1.6 CERTIFICATION, CLASSIFICATION AND IDENTIFICATION	9	3.5.2 Fire-fighting system control tie rod.....	62
1.6.1 Yacht identification specifications	9	3.5.3 Maintenance of fixed fire-fighting systems.....	64
1.7 LOAD-CARRYING CAPACITY.....	11	3.5.4 Restoring the fire-fighting system in the engine room.....	65
		3.5.5 Fire-fighting system in the engine room.....	66
		3.5.6 General information to prevent fire	67
2 - SAFETY RULES		3.6 GARAGE FIRE-FIGHTING SYSTEM	69
2.1 SAFETY RULES	14	3.6.1 Garage ventilation system diagram	70
2.1.1 Use-related rules.....	16	3.7 LOCATION OF SAFETY PLATES	71
2.1.2 Maintenance rules.....	18	3.8 MANDATORY SAFETY EQUIPMENT	72
2.2 SAFETY RULES FOR YACHT MAINTENANCE.....	19	3.9 ITEMS USEFUL TO HAVE ON BOARD	73
2.2.1 Fire prevention rules	23	3.10 SCHEDULE	74
2.3 ENVIRONMENT REMARKS.....	25		
2.4 REGULATIONS FOR WASTE DISPOSAL.....	26		
		4 - DESCRIPTION OF THE YACHT	
3 - SAFETY DEVICES AND EQUIPMENT		4.1 MAIN DIMENSIONS AND CHARACTERISTIC DATA OF THE YACHT	76
3.1 STANDARD SAFETY EQUIPMENT	28	4.2 GENERAL ARRANGEMENTS	78
3.1.1 Safety and fire-fighting equipment layout.....	30	4.2.1 Keys of the yacht	79
3.1.2 Self-inflatable life raft	31	4.3 MAIN DECK - EXTERIOR	81
3.1.3 Signalling rockets.....	33	4.4 MAIN DECK - INTERIOR	85
3.1.4 First aid kit.....	34	4.5 UPPER DECK	88
3.1.5 Portable fire extinguishers	35	4.5.1 Helm station	89
3.1.6 Portable fire-extinguishers maintenance.....	37	4.6 LOWER DECK	90
3.1.7 Individual life jacket.....	38	4.6.1 Crew cabin and bathroom.....	91
3.1.8 Life buoy	40	4.6.2 Cabins with bathroom: Guests and VIP	92
3.1.9 VHF-Radiotelephone	41	4.6.3 Porthole.....	92
3.1.10 EPIRB	43	4.7 FLY BRIDGE	93
3.1.11 Emergency boarding system	44		
3.2 YACHT'S AREAS	45		

4.8	ANTENNAS, NAVIGATION LIGHTS AND DAYLIGHT SIGNALS	94	6.4.2	Maintenance of black and grey waters draining system	155
4.8.1	Antennas	94	6.5	BILGE AUTOMATIC SUCTION SYSTEM	158
4.8.2	Navigation lights	96	6.5.1	Main bilge system	158
4.8.3	Mast daylight signals	100	6.5.2	Maintenance of bilge automatic suction system	161
4.9	ENGINE ROOM	102	6.5.3	Multipurpose pump system	163
			6.6	SCUPPERS SYSTEM	164
5 -	HELM STATIONS		7 -	ELECTRIC SYSTEM	
5.1	HELM STATIONS	104	7.1	ELECTRIC SYSTEM	168
5.2	SUN DECK HELM STATION	106	7.1.1	Maintenance of the electric system	176
5.3	UPPER DECK HELM STATION	108	7.2	ELECTRICAL PANELS	177
5.4	THIRD COCKPIT HELM STATION	111	7.2.1	Main electrical panel	177
5.5	INSTRUMENTATION	112	7.2.2	Synoptic panel in the main helm station	190
5.5.1	VHF-DSC Radiotelephone	112	7.2.3	120/240V bow electrical panel	191
5.5.2	Throttle	114	7.2.4	24V bow electrical panel	196
5.5.3	Engine control panel	116	7.3	GROUND PROTECTION	201
5.5.4	Control panel for the bow/stern thrusters	116	7.4	FUSES	203
5.5.5	Digital chain counter	116	7.5	BATTERY SET	204
5.5.6	Steering wheel	116	7.5.1	Maintenance of the batteries	206
5.5.7	Radar / Chartplotter / Depth sounder	117	7.6	BATTERY BREAKER PANEL	208
5.5.8	Automatic pilot	118	7.7	SHORE ELECTRIC POWER SUPPLY	211
5.5.9	Magnetic compass	120	7.8	BATTERY CHARGER	214
5.5.10	WATCHIT system (optional)	121	7.8.1	Battery charger maintenance	218
			7.9	INVERTER SERVICES	220
6 -	WATER SYSTEMS		7.9.1	Inverter services maintenance	221
6.1	FRESH WATER SYSTEM	124	7.10	GENERATORS	222
6.1.1	Watermaker	129	7.10.1	Power generator control panel	224
6.1.2	Cold fresh water system	130	7.10.2	Generator maintenance	225
6.1.3	Hot fresh water system	131	7.11	REFRIGERATOR SYSTEM	228
6.1.4	Maintenance fresh water system	132			
6.2	SEA WATER SYSTEMS	136	8 -	PROPULSION SYSTEMS	
6.2.1	Maintenance of seacocks and strainers	140	8.1	PROPULSION SYSTEMS	230
6.3	GREY WATER SYSTEM	143	8.2	ENGINES	231
6.4	BLACK WATER SYSTEM	147	8.3	ENGINE CONTROL PANEL	233
6.4.1	Toilet operation	153			

12.3.1	Weather	339
12.4	NAVIGATION SET UP PROCEDURES	340
12.5	FIRST PERIOD OF USE.....	342
12.6	DEVICES SETTINGS CARRIED OUT BY THE OWNER.....	344
12.7	REFUELLING.....	345
12.8	WATER SUPPLY.....	347
12.9	MOORING AND UNMOORING	347
12.9.1	Leaving the mooring	348
12.9.2	Strength points.....	349
12.9.3	Mooring manoeuvre.....	349
12.9.4	Unattended mooring	350
12.10	YACHT OPERATION DURING NAVIGATION.....	351
12.10.1	Operating in shallow water.....	352
12.11	PRECAUTIONS DURING NAVIGATION	353
12.12	PREPARATION FOR ANCHORING.....	355
12.13	SUGGESTIONS FOR NAVIGATION UNDER SPECIAL CONDITIONS.....	356
12.13.1	Navigation with bad weather conditions.....	356
12.13.2	Navigation with one only engine	358
12.14	ENGINE EMERGENCY SUCTION FROM THE BILGE.....	360
12.15	HAULAGE AND LAUNCH.....	361
12.16	DRAWING THE YACHT IN CASE OF FAILURE (OR TOWING)	364
12.17	BOAT STEERING RULES	366

13 - HULL AND FURNITURE MAINTENANCE

13.1	GENERAL MAINTENANCE OUTLINES.....	370
13.2	LONG PERIODS OF YACHT INACTIVITY	372
13.3	RE-USE OF THE YACHT AFTER A LONG INACTIVITY	374
13.4	HULL MAINTENANCE	376
13.4.1	Bottom hull	377
13.5	GENERAL MAINTENANCE	378
13.6	MARBLE MAINTENANCE	392
13.7	SPEED MULTISENSOR (LOG) MAINTENANCE	394

14 - TROUBLESHOOTING

14.1	TROUBLESHOOTING	396
14.2	PROPULSION ENGINES	397
14.3	GEAR BOX	401
14.4	GENERATORS	404
14.5	BATTERY CHARGER	406
14.6	INVERTER	408
14.7	USES	409
14.8	FUEL SYSTEM	410
14.9	BLACK OR GREY WATER DRAINING SYSTEM.....	411
14.10	FRESH WATER SYSTEM.....	412
14.10.1	Watermaker	413
14.11	BILGE PUMPS.....	414
14.12	HYDRO-ELECTRIC STEERING SYSTEM.....	416
14.13	AIR CONDITIONING SYSTEM.....	419
14.14	GANGWAY	421

Riva

102 CORSARO *supera*

FOREWORD

CHAPTER 1

1.1 GENERAL INFORMATION

NAME OF THE YACHT _____ 102 CORSARO super
 TYPE OF YACHT _____ MOTOR YACHT
 PROJECT CATEGORY _____ A



CAUTION

Category A: This yacht is designed to navigate in conditions where the wind force can be greater than 8 on the Beaufort scale and the significant wave height is greater than 4 m and is largely self-sufficient.

Excessive conditions such as hurricanes are excluded. These conditions may be encountered on long crossings, e.g. interoceanic, or near the coast, exposed to wind and waves for several hundred nautical miles.

1.1.1 Introduction to using the manual

Prior to operate the yacht and the equipment on board, read the manual carefully, in order to acquire an adequate familiarity with the systems and their operation, so as to avoid hazard to personnel and risks of costly damages.

Constant and regular maintenance of the on-board systems and of the yacht allows to extend its life and safe operation.

The maintenance operations described in the manual are simple, but should be performed by authorised and qualified technical staff only in compliance with national and international regulations.

For specific interventions it is advisable to request the service of specialized technicians or contact our Service Department.

1.1.2 Organization of the manual

For an easy and quick consulting, the manual is subdivided in the following sections:

- FOREWORD
- SAFETY RULES
- SAFETY DEVICES AND EQUIPMENT
- DESCRIPTION OF THE YACHT
- HELM STATIONS
- WATER SYSTEMS
- ELECTRIC SYSTEM
- PROPULSION SYSTEMS
- STEERING SYSTEMS
- AIR CONDITIONING SYSTEM
- AUXILIARY EQUIPMENT ON BOARD
- INFORMATION FOR USE
- HULL AND FURNITURE MAINTENANCE
- TROUBLESHOOTING



CAUTION

Please keep this manual carefully in a safe, dry and easily accessible place for an easy consultation.

When you decide to change the yacht, deliver this manual to the new owner in its integrity.

1.2 MANUAL INTRODUCTION

The documentation provided by RIVA to the Owner consists of two types of documents:

- The “**Owner’s Manual**”, edited by experienced professional staff in compliance with the regulations in force;
- The **Technical Document Collection**, concerning the on-board devices/systems (engines, air conditioning, etc..): It consists in a series of independent manuals, delivered by the relevant Manufacturer and/or Suppliers.

The Owner’s manual is the Main Document and must be read in whole, in any case before considering the documents in the Technical Document Collection.

The associated Technical Documentation Collection makes up the set of the Reference Documents that are required to complete the information provided in the Owner’s Manual.

Since these documents are independent and aimed at giving information on specific single components, it is necessary to refer to them when indicated by the Main Document.



CAUTION

RIVA recommends carefully reading the whole documentation delivered by the Manufacturers of the various components.

For all problems concerning the use and the maintenance of components you can refer directly to the Service Departments listed in the documents delivered by the Manufacturers.

Anyway, in case of need, some little interventions can be carried out by the staff on board, after consulting the operation manual.

This manual has been drawn up by RIVA in their mother language (Italian) and translated into other languages, to satisfy the customer’s requirements, and has been issued with the purpose of assisting you with the use of your yacht in full safety and with complete satisfaction.

This manual contains a detailed description of the yacht, of the systems and devices installed and practical information about its use and maintenance.

The modifications that may affect the safety features of the yacht should be evaluated, carried out and documented by competent people. The manufacturer of the yacht can not be held responsible for changes that are not approved.

We recommend that you carefully read through this manual so as to become familiar with its contents before starting to navigate for the first time.

If this is your first yacht, or if this is a type of yacht that you are not familiar with, for your safety and to ensure your maximum satisfaction, make sure you have acquired sufficient experience about how to use and operate the yacht, before “taking the command”.



CAUTION

Make sure that the conditions of wind and sea correspond to the design category of your yacht and that you and your crew are capable of manoeuvring the yacht in such conditions.

Also when your yacht is classified accordingly, the conditions of sea and wind corresponding to design categories A, B and C ranging from storm conditions for category A to the conditions of wind and strong sea for the upper limit of category C, exposed to the dangers of a rogue wave or a wind gust.

These are therefore dangerous conditions, where only a competent crew, coached and trained on well-maintained yacht can operate satisfactory.

THIS MANUAL MUST BE STORED AND WILL ALWAYS BE ON THIS YACHT AT EVERY TRANSFER OF PROPERTY.

SANCTIONS ARE ENVISAGED IF THE YACHT IS NOT EQUIPPED WITH THE "OWNER'S MANUAL".

IN CASE YOU LOSE OR DAMAGE THIS MANUAL, RIVA WILL ALWAYS BE ABLE TO SUPPLY YOU WITH A NEW COPY OF IT.



CAUTION

RIVA declines all responsibility for any damage to third parties due to discrepancies between the manual and reality.



CAUTION

This manual contains pictures of details not representing completely our yacht or with colours not corresponding to your arrangements. This is mainly due to the fact that it is possible to encounter problems during the realization of details' photos, like bed covers and sofas, which are defined only shortly before yacht delivery and therefore when the manual itself has already been issued.



CAUTION

In some countries, a license or permit to drive are required, or specific regulations are in force.

This yacht may be conducted exclusively by authorized personnel to command and to the conduct of pleasure yacht in relation to the same class of the yacht.



CAUTION

All yachts, regardless of their strength, can be seriously damaged if used improperly. This is not compatible with safe navigation.

Always adjust the speed and course of the yacht under the sea conditions.



CAUTION

If the yacht is equipped with a life raft, carefully read the operating manual. The yacht should have on-board the appropriate safety equipment (life jackets, safety line, etc..) depending on the type of yacht, to the weather conditions, etc.. This equipment is mandatory in some countries. The crew should be familiar with the use of all safety equipment and emergency manoeuvring (man overboard recovery, towing, etc..), sailing schools and clubs regularly organize training sessions.



CAUTION

All people should wear a suitable buoyancy aid (life jacket / personal flotation equipment) when they are on the deck.

Note that, in some countries, it is a legal requirement to always wear a buoyancy aid that complies with the applicable regulations.

1.3 SERVICE REQUEST PROCEDURE - WARRANTY

The extensive RIVA service network is glad to provide you with any information regarding issues not addressed by the manual.

Customers may contact Dealers, Sale Offices, Service Centres or directly:

RIVA AFTER SALES & SERVICE DEPARTMENT
Via Ansaldo 7 - 47100
Forlì - Italy
Tel +39 0543 474445
Fax +39 02 70058589
customer.service@riva-yacht.com

RIVA has carefully selected all main components and accessories installed on-board your yacht, choosing among the most reliable manufacturers who, by offering a wide service network, also guarantee a speedy availability of spare parts.



CAUTION

For all aspects related to the warranty of the yacht, please exclusively refer to what indicated in the sale agreement and in the warranty certificate in which all warranty conditions applicable to the purchased product are specified.



CAUTION

The maintenance operations described in the manual are simple, but should be performed by authorised and qualified technical staff only, according to the standard procedures delivered by the devices Manufacturers and in compliance with national and international regulations. We suggest contacting the RIVA After Sales & Service Department.



CAUTION

RIVA declines all responsibility for damage due to improper preservation and poor maintenance.



CAUTION

RIVA declines all responsibility for the installation and operation of electric, electronic or mechanical equipment improperly installed by third parties in any unauthorised way by the Shipyard.



WARNING

RIVA declines all responsibility concerning tampering carried out by third parties on equipment installed in the Shipyard. Such tampering or unauthorized installations will not only void the warranty, but may cause damage to the yacht and injuries to the people on board.



WARNING

Equipment and devices: engine, winch, extractors and other devices are guaranteed by their manufacturers, who will service them directly through their service points. In case of need, the RIVA After Sales & Service Department will support your requests in order to provide you with a quick service and to guarantee the respect of the applicable rules. Upon yacht purchase, the Owner must send the Warranty Certificates of the relevant Manufacturers, in order to start the warranty period. RIVA will not be liable for undelivered Warranty Certificates.

1.4 NOTICES

To highlight particularly significant sections and/or to indicate some important requirements, some symbols have been defined as follows.



CAUTION

It indicates a reminder to apply certain safety measures or to avoid certain unsafe practices that could lead to personal injury or damage to the yacht, to its components or to the environment.



WARNING

It indicates the existence of a possible hazard that may lead to personal injury or death, if proper safety precautions are not taken.



DANGER

It indicates the existence of a serious hazard that could involve a high probability of death or of serious injury if suitable safety precautions are not taken.



ENVIRONMENT

This symbol draws your attention to the possible hazards of environmental pollution.

NOTE

Draws your attention on information and important memos.

MAINTENANCE

This symbol indicates the maintenance schedules on the various on board devices.

1.5 SPECIFIC SAFETY WARNINGS

They integrate the general safety notice and are aimed at providing specific information about the nature of possible dangers.

Fire hazard:

To indicate a specific fire hazard.



DANGER

The cause of fire breaking is described here.

Electrocution hazard:

To indicate a specific electrocution risk.



DANGER

The cause of electrocution is described here.

Burn hazard:

To indicate a specific burn hazard.



DANGER

The cause of burn is described here.

Forbidden areas:

To forbid the access, the transit or the stay in a dangerous area.



DANGER

This area describes the forbidden area: for forbidden areas are meant dangerous places or the approaching to mechanical moving parts.

1.6 CERTIFICATION, CLASSIFICATION AND IDENTIFICATION

RIVA has been operating in the international market for many years, with the purpose of building safe and high-quality yachts; for this reason, their yachts undergo rigid and accurate tests required by the international Authorities to issue a CLASSIFICATION CERTIFICATE.

1.6.1 Yacht identification specifications

Manufacturer	FERRETTI S.p.A.
Model	RIVA 102 CORSARO super
Type of yacht	MOTOR YACHT
Identification number CIN (Craft Identification Number)	IT-FERRCS19C626
Identification number HIN (Hull Identification Number)	XFARCS19C626
Navigation class	A (open sea navigation: the wind force can be higher than 8 and the wave height can exceed 4 metres)
Certification forms	B+F+A1 (sound emission)
Classification	“EC” conformity according to the standards stated by the Directive 2013/53/EU

In the figure aside you will find two plates shown in detail: Manufacturer plate and yacht identification code plate.



CAUTION

Manufacturer's plate - Part of the information is provided on the Manufacturer plate affixed to the yacht. A full explanation of this information is provided in the relevant sections of this manual. Always keep the plate readable, and, if impaired, or tampered with, contact RIVA After Sales & Service Department.



CAUTION

Category A: A yacht designed to navigate in conditions where the wind force can be greater than 8 on the Beaufort scale and the significant wave height is greater than 4 m and is largely self-sufficient. Excessive conditions such as hurricanes are excluded. These conditions may be encountered on long crossings, e.g. interoceanic, or near the coast, exposed to wind and waves for several hundred nautical miles.

The significant wave height is the average height of the waves that make up the highest third of the same, which is approximately wave height estimated by an experienced observer. Some waves are twice this height.



1.7 LOAD-CARRYING CAPACITY

Maximum number of people	n° 20
Maximum load-carrying capacity	kg 4250 (people + luggage)
Safety equipment (standard)	n° 20
Sleeps	n° 15

Divided into:

- 2 in the master cabin (double bed);
- 2 in the port-side VIP cabin (double bed);
- 2 in the starboard VIP cabin (double bed);
- 2 in the port-side guest cabin (double bed);
- 2 in the starboard guest cabin (single beds);
- 1 in the captain's cabin (single bed);
- 2 in the port-side crew cabin (single beds);
- 2 in the starboard crew cabin (single beds);



WARNING

Do not exceed the maximum recommended number of people. Regardless of the number of people on board, the total weight of people and equipment must never exceed the maximum recommended load. Always use the seats/seating spaces provided.



CAUTION

Make sure that safety equipment is perfectly efficient and available to each passenger.



CAUTION

The maximum load recommended by the manufacturer excludes the mass of the contents of the fixed fuel and water tanks when full. It must exceed the total load that can be added to the displacement to download and dry yacht.



CAUTION

The maximum load carrying-capacity includes the weight of all people on board, all their luggage and personal effects and any other equipment not included in the unladen displacement.



CAUTION

When the yacht is being loaded, never exceed the maximum load carrying capacity. Always take great care when loading the yacht and try to distribute the loads evenly so as to keep the correct trim. Avoid placing heavy loads in the upper part to not reduce the stability.



CAUTION

The safety equipment provided by the manufacturer are provided for the maximum number of transportable persons. Before navigation, check that the number of safety equipment is always greater than or equal to the number of persons on board.



Riva

102 CORSARO *supera*

Riva

102 CORSARO *supera*

SAFETY RULES

CHAPTER 2

2.1 SAFETY RULES

Your yacht has been designed paying maximum attention to all aspects regarding your safety and the safety of Your guests. However, all personnel on board must be instructed and aware about some precautions to be adopted at all times.

For this purpose, it is advisable that all people on board carefully read the guidelines contained in this manual, as well as the signs installed on the yacht and, in particular, all safety notices.

The time spent in reading such instructions will prevent unpleasant accidents.

Remember that you are responsible for your safety and the safety of your passengers, and that you may jeopardize the safety of other boats.

Please make sure you are perfectly aware of the main safety rules:



DANGER

Only the personnel having a regular license or the necessary qualifications can steer this yacht.
Personnel operating the yacht must not be under the influence of alcohol, drugs or narcotics.

- During normal operation or any activities on the yacht, keep passages and escape routes in proper conditions, in order to avoid hazards to people's safety;
- Always perform regular inspections of hull conditions, power system, safety equipment and systems on a regular basis;
- Always check the fuel level before navigation and compare the tanks' capacity with the engines' consumption, the length and the expected type of cruise;
- Check the expected weather conditions in your navigation area;
- In any case, always act according to common sense.

2 - SAFETY RULES

Safety is also "in the hands" of all those on board, who should be instructed and aware of some precautions to be adopted all times:

- Move carefully around the yacht because its stability may be suddenly affected by the sea waves;
- People on board must know the location of life jackets, how to wear them and the location of fire extinguishers (see safety equipment) and of the life raft;
- All passengers must be aware of the risks caused by the fires and the correct way to proceed in the event a fire should occur;
- The engine room must be properly ventilated when the engines are running;
- Everybody on board must be able to release and launch the life buoy and the life raft at sea;
- Access to the engine room must be allowed only to authorized personnel, aware of possible dangers like:
 - Moving mechanical parts;
 - Hot parts and components;
 - Circuits with pressurized, hot or irritating fluids;
 - Circuits with flammable fluids;
 - High noise when engines are running;
 - Possibility to shift important valves for navigation safety unintentionally;
 - For navigation safety.
- It is the responsibility of the owner / user to have at least a bailer / bucket on board, fixed so as to prevent accidental loss.



DANGER

It is strictly forbidden to stay on weather decks without railings (i.e. aft platform) during navigation.

Do not tamper with, disconnect, eliminate or by-pass the safety devices installed on your yacht. Periodically check their real efficiency in time to ensure that they can be used in case of need. Failure to meet such requirements may lead to serious risks to the health and safety of passengers.

**WARNING**

Personnel performing any type of operation during the entire lifetime of the yacht must be technically qualified and have proven abilities and experience acquired and recognised in the specific field. The lack of such skills can endanger your safety as well as the safety of people on board and the integrity of the yacht.

Make sure any parts not stored or not secured correctly, cannot move during navigation, hinder the passage, prevent the opening of inner hatches, fall against the people on board, damage or hinder the quick finding of necessary pieces.

**CAUTION**

Always pay the necessary attention while navigating, especially in adverse weather conditions or breaking waves.

2.1.1 Use-related rules



DANGER

Carbon monoxide poisoning

Fossil fuel combustion generates high quantities of carbon monoxide. This gas is a colourless, odourless and highly toxic.

When the engines and/or the generator are running, the yacht must be properly ventilated, in particular if underway at low speed, or when the exhaust fumes may blow back on board (e.g. when the yacht is shored or anchored or riding the anchor).

Arrange the load evenly so as to keep the correct trim.

Do not overload the yacht especially at bow and aft.

Observe the rules to prevent a sea collision and respect the speed limits; moreover always pay the utmost attention during navigation.



WARNING

The Captain is the only person responsible for driving the yacht. Prior to departure, the Captain must ensure that the safety equipment required by law is present on board and perfectly working.

The Captain should always meet the requirements and have the specific qualification to steer this yacht as requested by the laws in force in the country of use.

After becoming duly informed as to the operation and controls of the yacht, at first use the Captain should simulate some test manoeuvres, to locate the controls and to be aware of the common reactions of this yacht.



WARNING

Do not use the yacht if the safety equipment is inoperative. Failure to meet such requirement may cause serious risks to the safety and health of passengers.

The basic operations like start, navigation, anchorage and mooring must be carried out and checked thoroughly; in particular all procedures for navigation set-up should strictly be observed.



WARNING

At high speed, the use of the autopilot is dangerous and not recommended. Always be very careful during navigation even when the autopilot is in use.

All refuelling phases have to be carried out with the necessary precautions to avoid even the smallest spillage of products which could pollute the environment.

When navigating near harbours, beaches and shores, observe the directives issued by local port authorities, particularly as to the speed; high speed can originate wake waves which can jeopardize the safety of the environment and of people.

Before lowering the anchor in free waters, be aware of the kind of sea bottom underneath and near your yacht, to avoid damaging it.

**CAUTION**

In the case of using a jet-ski, every passenger must wear a life jacket; the driver must also possess a valid license and follow the rules of the country where it is located.

**CAUTION**

Close portholes, windows and skylights during navigation, especially in poor weather conditions.
Also, make sure that you have closed or locked doors to prevent collisions with objects or people.

**CAUTION**

Any changes in the distribution of the masses on board, such as the addition of weights on top, a structure or the replacement of components with different specifications, can significantly affect the stability, trim and performance of the yacht.
In these cases, contact RIVA After Sales & Service Department.

**CAUTION**

Pay maximum caution in the towing phase and/or weight lifting with a crane or boom, as the stability of the yacht can be significantly reduced.

**CAUTION**

The bilge water is to be reduced to a minimum.
The yacht's stability is compromised with the addition of weights on top.
In the event of rough seas: cabinets and doors must be closed to reduce the risk of flooding.
Crashing waves are a serious danger to stability.

**CAUTION**

Avoid sudden manoeuvres at high speeds.

**CAUTION**

For comfort and safety, reduce speed in the presence of waves.

**CAUTION**

Do not remove or move any weight placed under the flooring in the deck floor.

2.1.2 Maintenance rules

Keep your yacht in conditions of the highest efficiency,, carrying out all scheduled maintenance of the devices on board.

A good maintenance will provide the best performance, a longer useful life and a constant respect of the safety requirements.

For the general cleaning of your yacht, only use bio-degradable or environmentally friendly products.



ENVIRONMENT

During navigation, do not release any on-board waste at sea, but keep it and dump it in waste containers ashore.

Remember that it is forbidden to dump oils and fuels into the sea; therefore, it is recommended to clean the engines' bilges by using absorbent materials to be disposed of later on into dedicated containers.

Before carrying out maintenance and adjustment operations on your yacht, activate all safety devices provided and evaluate if it is necessary to inform all persons on board. In particular, place warning signs in the nearby areas and prevent access to any device that, if operated, could cause unexpected hazardous conditions, thus endangering the people and/or property on board.

Maintenance and adjustment operations must be carried out by authorized personnel who must use all necessary protections according to the procedures provided by the Manufacturer.

All maintenance operations requiring a precise technical knowledge or particular skills must be carried out exclusively by qualified personnel with a recognised experience, acquired in the specific field of intervention.

To carry out maintenance in an area that is not easily accessible, or dangerous, take all of the necessary safety measures, according to rules and standards applicable to safety at work.



ENVIRONMENT

Any maintenance operation must be carried out in the strict respect of the surrounding environment. Take all necessary measures to avoid that even one single "oil drop" may be spilled: the protection of our environment starts with this type of attention.

Access to the engine room during navigation must be limited only to authorized personnel.

Inspect the sea water system inlets and outlets as well as the bilge systems. These checks are vital to ensure yacht buoyancy.

Do not perform any maintenance operations or adjustments other than those indicated and/or suggested by the Manufacturer. If necessary, contact the Service Centre for more precise instructions.

Keep all yacht's components clean by following the procedures and using the specific products suggested by the Manufacturer.

Only replace worn parts using original spares.

Use oils and greases recommended by Manufacturer. This will ensure yacht functionality and the expected safety level.

2.2 SAFETY RULES FOR YACHT MAINTENANCE

Do not start any work before ensuring that people on board are not in danger.

If something about the work to be carried out is doubtful, ask someone with knowledge.

Do not draw any conclusions.

Always operate with caution, care and under safety conditions.

Apart from regulations stated in this manual, specific warnings are given throughout. This section is meant to provide safety rules for the operation and maintenance procedures.



CAUTION

This section includes a certain amount of information to maintain the components without dangers. Remember that each time you activate the controls, you are in control of the yacht.

You must therefore read and understand the information given before activating the controls.



CAUTION

The use of faulty lifting attachments can be the cause of accidents; therefore, check their efficiency. Ensure the compliance of hoisting gears with local norms and their suitability for the job they have to carry out. Also check their soundness according to the work to be carried out.

You must therefore read and understand the information given before activating the controls.



CAUTION

The use of unsuitable clothing can cause accidents; do not wear loose, flapping clothes which could be easily get caught in the yacht's moving parts. Wear protective clothes suitable for the kind of work to carry out (helmets, safety shoes and protective goggles, overalls). Button cuffs, do not use ties or scarves and do not leave your long hair loose.



CAUTION

It is extremely dangerous to operate on the yacht controls under the influence of alcohol or drugs. Never take alcohol or drugs before or during work. Do not take medicines that cause dizziness.



CAUTION

Be alert and use the greatest caution while working. Take great care to avoid possible dangers.



CAUTION

Lifted equipment may fall and hurt you. Do not walk or work under lifted devices not sufficiently and safely supported.

**DANGER**

The engines moving parts are dangerous; do not open hatches while running the yacht.

**CAUTION**

Yacht entrance. Always turn to the yacht to enter or leave it and use the handles and the steps. Make sure that steps, handles and rubber soled shoes are clean and dry. It is advised to remove the shoes. Do not jump down from the yacht, do not use the yacht controls as handholds; use the handles.

**CAUTION**

Activating the **throttles** from outside the helm station can cause serious accidents even fatal ones: controls must only be operated from the correct position in the helm station.

**CAUTION**

Metallic chips from working with metallic parts can cause injury: always wear safety goggles and use a soft mallet or punch.

**CAUTION**

Insufficient **information** may cause accidents. If two or more people are working simultaneously in the same area, make sure that each one of them is aware of the operation carried out by the others. Before starting the engine, move the other persons from the risky areas (rotary blades and engine belt, tools and movements, engine inner and rear parts). Failure to comply with these precautions may cause serious injury, and even death.

**DANGER**

Do not approach unprotected flames to the yacht. Do not smoke during refuelling or while working on the engine. Carry out refuelling with the engine shut OFF. Failure to comply with these precautions can cause accidents and injuries.

**CAUTION**

A frozen **battery** may blow up if used or charged; do not start a yacht with a frozen battery. To prevent the battery from freezing always keep it completely charged.

**DANGER**

The **battery** releases explosive gas: do not allow sparks or flames to come close to the battery and never smoke near it. If the battery is used or charged in a closed area, check for good ventilation. Do not check the battery charge by short-circuiting the terminals with metal tools: use a density gauge or a voltmeter.

**CAUTION**

Do not remove the tank **filling plug** when the engine is ON, because the hydraulic system under pressure may cause injury. Stop the engine before releasing pressure.

**CAUTION**

The spilling of hydraulic oil under **pressure** may cause injuries: before disconnecting or connecting the hoses, stop the engine and operate the controls to release the residual pressure. Prevent the engine from starting when the hoses are disconnected.

**CAUTION**

If damaged, the **hydraulic hoses** may cause death, carry out appropriate periodical checks to check for the presence of:

- Damaged fittings;
- Wear of outer coatings as consequence of rubbing;
- Swelling on outer coatings;
- Bent or squashed hoses;
- Fittings not properly located.

**CAUTION**

Oil is poisonous: do not swallow. The engine oil contains dangerous polluting agents which can generate skin tumours. Handle oil as little as possible and, protect your skin with creams and gloves. Any skin that comes into contact with oil must be washed carefully with warm water and soap: do not use petrol, fuel or oil.

**CAUTION**

Hydraulic oil spraying at high pressure penetrates the skin: do not check for oil leaks with your fingers or allow your face to become too close to them. Use a cardboard strip to verify the possible presence of hydraulic oil. If oil penetrates the skin, ask immediately for a doctor for the relevant treatment.

**CAUTION**

Clean the cylinders of the **interceptors** periodically to remove possible dirt build up, which can jeopardize their efficiency. To reduce the risk of corrosion, pull back the rods each time you leave or you harbour the yacht.

**CAUTION**

The **cleaning** of metallic parts with unsuitable solvents may cause corrosion; use detergents and solvents of the prescribed type only.

**CAUTION**

Seals and O-rings fitted incorrectly, or damaged or worn out may cause leaks or accidents; replace them immediately except when otherwise prescribed. Do not use trichlorethane or solvent near O-rings and seals.

**DANGER**

Hot coolant. When the engine temperature is high, the cooling system is under pressure and the hot fluid can spill over when you remove the radiator plug.

Therefore, before removing it, wait until the system has cooled down, then turn the plug up to the first notch and release the system's pressure.

**CAUTION**

During the restoring operations of metallic or non metallic components, wear **safety glasses**. Move away from the area or protect possible flammable materials, which could catch fire from sparks.

2.2.1 Fire prevention rules



DANGER

On all yachts, fire is a major danger.
All fire prevention measures must be followed scrupulously.

Before steering a yacht, the Captain must be perfectly aware of the following fire prevention measures.

At all times the yacht must be equipped with portable extinguishers, located as shown in the figure "Safety equipment arrangement".

The yacht's Owner and the Captain are directly responsible for:

- Having fire extinguishers and fire-fighting equipment overhauled as scheduled on their labels, and having them replaced, as required by the rules in force, with similar or equivalent or higher capacity ones;
- Informing the crew about the location and use of fire extinguishers and fire-fighting systems and escape routes;
- Ensuring that fire extinguishers are also available in the passengers' cabins.



CAUTION

The engine room of this yacht is equipped with a dedicated fire-fighting system.



WARNING

NEVER:

- Obstruct passageways and the escape routes;
- Hinder access to safety devices, such as fuel valves, electrical switches, etc..;
- Obstruct access to fire extinguishers stowed inside the lockers;
- Leave the yacht unattended, when burners or heat generating equipment are on;
- Use naked flames;
- Modify electric or fuel supply systems, without consulting RIVA beforehand;
- Smoke near or when handling flammable materials;
- Stow highly flammable materials (such as fuel, thinners, etc..) in proximity to heat sources, such as engines, galley, etc..;
- Stow flammable material in the engine room. Non-flammable materials may be stowed only if properly rigged, so they do not accidentally come into contact with rotating engine parts, or obstruct access to the engine room.

Keep the bilge clean and check it frequently for any oil or fuel leaks.



WARNING

EXPLOSION HAZARD

Any lithium battery powered device on board must be recharged only in open air areas, connected to a suitable charging system. Also please refer to the device dedicated Use and Maintenance Manual.

**CAUTION**

In case fire breaks out in proximity to electrical equipment, do not use water, but use the manual dry-powder fire extinguishers only. After using the extinguishers, leave and ventilate the area immediately before re-approaching it, in order to prevent asphyxia and physical harm. Clean out any fire extinguishing powder out very carefully.

In addition to these requirements, RIVA recommends the following:

- Avoid smoking in the lower deck, especially in the engine room.
- Avoid dropping liquids in the bilge and keep it clean, especially the engine room. In case of fuel leaks from the engines or from the generator, operate as follows:
 - Stop all engines immediately;
 - Locate the leak cause and, if possible, repair it after closure of supply valves;
 - Dry and clean the bilge before restarting the engines, without draining at sea or in the harbour;
 - Do not stow flammable items in proximity to heat sources, like engines, burners, halogen light, etc..;
 - In case of yacht leak, try to remedy with plugs and/or rags, if possible, from outside;
 - In case a system of the yacht breaks, close all hull valves, locate and repair the leak if possible. Remember to reopen all hull valves not involved.

**CAUTION**

The Captain of a leisure yacht must be perfectly aware of the basic fire-fighting techniques and how to use the extinguishers.

In case of fire, follow the procedures described below:

- Keep calm and do not spread panic among the passengers;
- Stop the yacht, close the sea cocks and the drains;
- Set the battery breaker to "OFF";
- Close the air intakes in the engine room;
- Locate the fire and its origin;
- Avoid breathing smoke;
- Extinguish the fire, following standard fire extinguishing techniques.

**DANGER**

In case of the yacht sinking risk, close the fuel and black waters valves.

**CAUTION**

The reading of this section, containing all the information the Captain of the yacht should know, is strongly recommended.

2.3 ENVIRONMENT REMARKS

Environmental pollution is caused by three kinds of polluting agents:

- Water polluters;
- Air polluters;
- Soil polluters.

Non oily and black waters (containing only human organic waste) can be discharged into the open sea. In harbour areas they should be collected into suitable containers and afterwards discharged either during navigation into open sea or by means of special drainage systems fastened to the shore or wheel-conveyed (with optional black water tank).

Soil pollution is caused by discharging waste at shore.

International rules for leisure crafts essentially prescribe the following:

- During navigation it is forbidden to discharge any non biodegradable product, either of food or commercial origin, into the open sea.
- In the harbour, normal waste is considered urban waste that must be hermetically sealed in plastic bags and thrown into waste dumpsters.
- Special waste must be disposed of into suitable containers or, if these are not available, it must be delivered to local waste disposing areas, in compliance with the rules in force, issued by the local Port Authority.

- The following waste is considered special waste:
 - Water and oily mixtures (e.g. Bilge water);
 - Oils (fuel, additives and lubricants);
 - Poisonous chemical substances (like battery acids, paints, thinners and the relevant containers);
 - Spray cans containing C.F.C. gas;
 - Batteries;
 - Spent flares;
 - Expired pharmaceutical products;
 - Products containing lead or asbestos;
 - Etc..
- Fuel and oil leaks.
- Waste discharge and disposal.
- Excessive noise.
- Wake / wake from board.
- Exhaust fumes.
- Paints, detergents and other agents.

Please remember that, according to legislation, until such waste is delivered to suitable disposal areas, you will be considered as possessors and therefore indictable in case of unlawful discharge. Should specific cases be missing in the harbour area, the Authority in charge for the disposal is the Port Authority section "Waste Disposal".

2.4 REGULATIONS FOR WASTE DISPOSAL

The following chart is based on Appendix 5 of the International Convention for the prevention of pollution from ships (Marpol 73/78).

These regulations are applicable to all ships, regardless of their displacement and service; therefore, leisure crafts are also included.

The regulations apply to the entire Mediterranean Sea.



WARNING

When moored in a harbour, always check that your yacht is not a source of pollution. The environment must be respected and safeguarded, preventing risks for the life of aquatic flora and fauna.

It is good practice to leave no trace behind you, to respect laws on safety and environmental protection. Do not discharge bilge waste, oily residues, fuel or other liquids overboard.

Dispose of solid waste and old engine oil in the containers provided at mooring points.



WARNING

During navigation, it is always necessary to behave suitably and to respect the safety and the comfort of your guests and of people on nearby yachts. Therefore:

- Avoid excessive noise;
- Do not leave the engines running for long periods without moving off;
- Do not navigate at high speed or beyond the permitted limits when leaving or entering harbours, marinas, etc., to prevent causing excessive wash or wave motion.



CAUTION

It is absolutely prohibited to throw into the sea: plastic materials, synthetic cables, fishing nets, waste bags, floating packaging materials, cordage, paper, rags, glass, metals, bottles, galley tools and similar.

Non-comminuted or ungrounded food waste can be disposed of beyond 12 miles.



CAUTION

It is forbidden to use toilets or holding tanks near the shore or in any prohibited area. Use the facilities of the suction port or marina to empty the holding tank before leaving port.



ENVIRONMENT

Always consider and comply with local and international environmental laws against marine pollution (MARPOL).

It is advisable to consider local environmental laws and to respect the rules of good practice.

Although discharge at sea, except in special areas, of a wide range of ship-generated garbage is permitted at specified distances from the nearest land, preference should be given to disposal at shore reception facilities.

Riva

102 CORSARO *supera*

SAFETY DEVICES AND EQUIPMENT

CHAPTER 3

3.1 STANDARD SAFETY EQUIPMENT

Everybody on board must know the location and the use of safety equipment, that is: life jackets, life buoys, life buoys with line for “man overboard”, life rafts, extinguishers and fire extinguishing systems (i.e. in engine room, etc..) and radiotelephone.



CAUTION

The diagram shows the position indicated by the manufacturer for safety equipment; therefore represents a useful guide the placement and number.

It is the owner’s responsibility to adapt and place the safety equipment in accordance with local, national, and international laws.



CAUTION

The above-mentioned safety systems must comply with existing local and international navigation regulations, and which must be periodically inspected and maintained by qualified technical personnel, prior to the expiry date indicated on the systems.



CAUTION

The Captain is required to inform the crew on the yacht about the safety equipment, whether in case of fire or in case of sinking and listing.



CAUTION

Make sure that safety equipment is perfectly efficient and available to each passenger.



CAUTION

To navigate at a distance of over six miles from the coast, leisure crafts both with and without EC mark must have a deviation chart officially authorized by Maritime Authorities. To this purpose, the compass installed on board must be compensated by personnel authorized by the Harbour Master who, after completing the operation (compass turns), will issue the chart with residual deviations. These charts do not have an expiry date, and are therefore not renewed when periodic inspections are made for the renewal of the Safety Certificate. It is one of the responsibilities of the Captain of the yacht to verify correct compass operation and to update deviation values.



DANGER

Periodically inspect the wear conditions of safety equipment and check servicing or replacement dates, so that the equipment is always in perfect working order.

**DANGER**

CO₂ extinguisher uses CO₂ as an extinguishing medium it shall be used only to fight electric or galley fires.

⚠ WARNING

THIS EXTINGUISHER USES CO₂
AS AN EXTINGUISHING MEDIUM
IT SHALL BE USED ONLY TO FIGHT
ELECTRIC OR GALLEY FIRES

TO AVOID ASPHYXIATION
AFTER DISCHARGE
LEAVE THE AREA IMMEDIATELY AND
VENTILATE BEFORE ENTERING









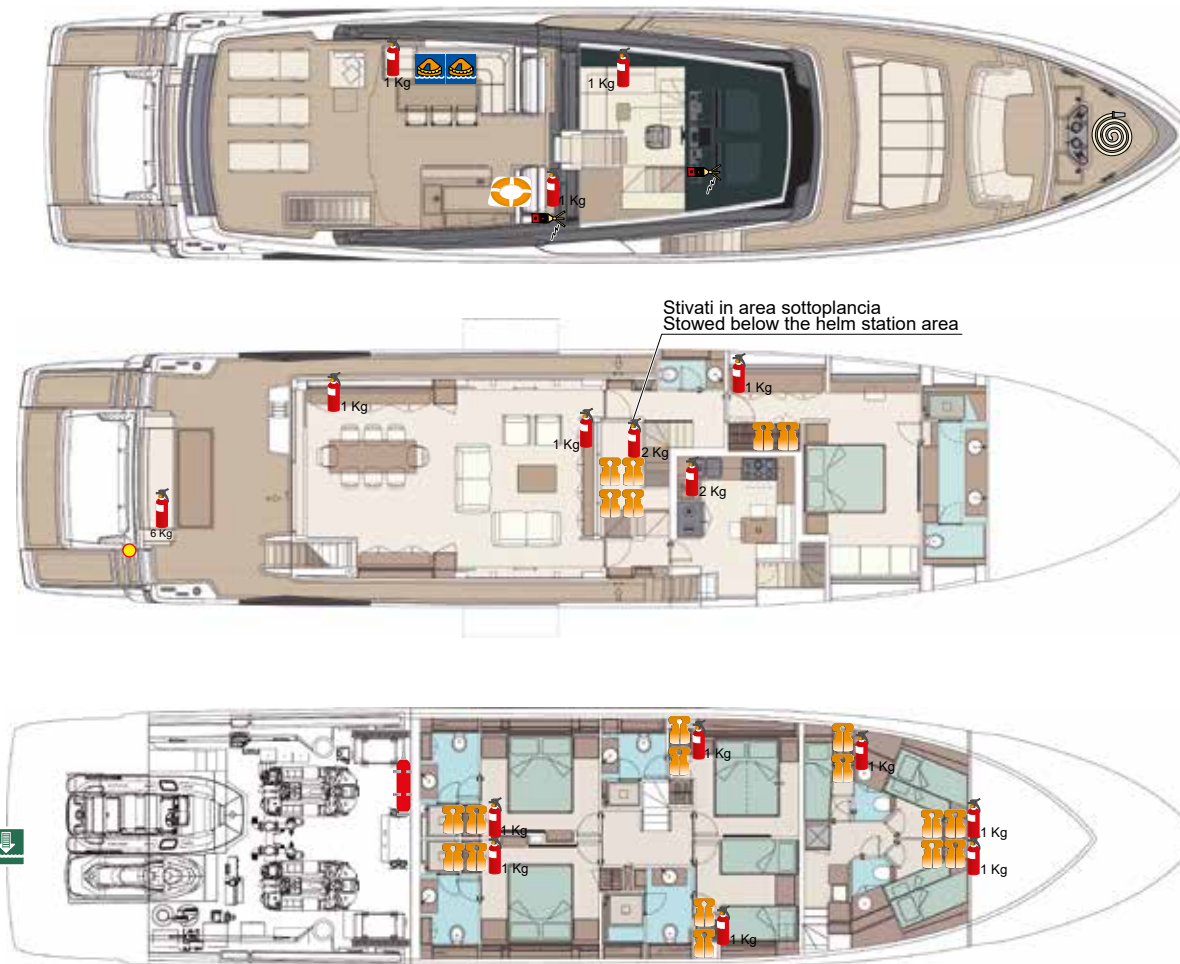

**DANGER**

To avoid asphyxiation after discharge leave the area immediately and ventilate before entering.

Your yacht can be equipped with an EPIRB (emergency position indicating radio beacon).

3.1.1 Safety and fire-fighting equipment layout



-  Manichetta
Fire hose
-  Zattera autogonfiabile: n°2 da n°10 posti
Self-inflatable life raft: n°2, 10 seats each
-  Salvagente anulare con cima e boetta luminosa
Lifebuoy with rope and light buoy
-  Giubbotti salvagente n°20
Life jackets No. 20
-  Estintori portatili a polvere da 6 Kg
6 kg portable fire extinguishers
-  Estintori portatili a polvere da 1 Kg
1 kg portable fire extinguishers
-  Estintori portatili a CO₂ da 2 Kg
2 kg portable CO₂ fire extinguishers
-  Estintore fisso: in sala macchine a gas tipo NOVEC
Fixed fire extinguishers:
n°1 in the engine room, gas NOVEC
-  VHF-DSC
-  Fire-port
-  Mezzo di risalita a bordo
Emergency boarding system

3.1.2 Self-inflatable life raft



WARNING

Before any trip, check that there are no impediments to its immediate use.

Self-inflatable rafts must be used only in case of real emergencies, requiring the abandonment of the yacht.

The yacht must in fact be abandoned in case a serious sinking hazard, or in case of fire becoming out of control. In all other cases careful evaluation is necessary, because to leave the yacht, even though on a self inflatable life raft, could mean more difficult identification by the rescue team.

As a matter of fact, the search for the shipwrecked will start exactly from the last known position of the yacht.

In case the use of self-inflatable life rafts becomes necessary, perform the following operations:

- Shut OFF the engines and wear the life jackets;
- Make the distress call using the VHF device;
- Uncoil the line of each life raft by 3 to 4 m; secure it tightly to a fixed point of the yacht and launch the self-inflatable life raft into the sea on the leeward side;



WARNING

Check that the line is always well fastened to the yacht.

- Unwind the line completely, then give a strong and decisive pull; the raft will open in a few minutes;
- Board by jumping directly from the yacht into the life raft;



- If the distress call has already been made and you have received an answer, prepare for a relatively short wait; then evaluate whether to cut or not the line. If you did not have the time to make the distress call or you did not receive an answer, prepare for a long wait; in this case, plan for survival, taking the following items, as well as the equipment included in the kit: floating smoke signals and rockets, a knife, drinking water and energy foods that do not cause thirst. Before boarding the life raft wear all possible clothing, except for shoes that could injure other shipwrecked persons or damage the life raft;
- Embark possible clothes and supplies;
- If somebody falls overboard, help him/her up into the life raft; throw the life buoy with line, if necessary;
- Make sure that everybody is on board, take the knife out of its sheath, and cut the line that ties the life raft to the yacht;
- Move quickly away from the sinking yacht, using the oars;
- When the overpressure valves have stopped hissing, close them by tightening the safety plugs.

**CAUTION**

The validity of the self-inflatable life raft is limited; check its expiry on the certificate. The life raft can be overhauled by a reliable entity extending its validity.

**DANGER**

If the life raft opens upside down, jump into the water and roll it over, by pulling the special rope.

If the life raft does not open after the first pull, repeat the operation two or three times. If the life raft still does not open, jump into the water and, keeping a hand on the container, pull the emergency line strongly. If the life raft still does not open, cut the container open with a knife and operate the opening device directly (by pulling the life line).

Differently from a life boat, the life raft cannot self-propel to the shore, unless blown there by favourable winds. Oars are only useful for small manoeuvres.

- The life raft is fitted with stabilisers and a floating anchor, for improving its stability and drift. The stabilisers give stability to the raft. Keep the floating anchor in the water. The anchor prevents excessively rapid drifts.
- When the life raft is towed, weigh the floating anchor on board.
- With very high waves and strong wind there is the risk that the raft may overturn: shift the weight of people on board towards the side tending to lift.
- If the life raft does capsize, roll it over and return on board. If the sea is rough, it is advisable to wear the life jackets all the time. If the raft deflates, inflate it again from time to time using the relevant inflating device provided with the raft.
- If air blows out of a hole, use one of the plugs stowed inside the repair kit.

- You can perform minor repairs, by using the glue provided with the kit. Clean the torn area and the repair pad, spread both with the glue. Hold the pad for thirty seconds, pressing from the centre outwards, in order to eliminate any air bubbles.
- Hold down for a little time and inflate again, after one hour.

**DANGER**

All people on board must know the location of self-inflatable raft storage and the correct use procedures.

**DANGER**

With very high waves and strong wind there is the risk that the raft may overturn: shift the weight of people on board towards the side tending to lift.

If the life raft in spite of all does capsize, roll it over and return on board.

NOTE

For further information on use and maintenance, please refer to the manufacturer's manual.

3.1.3 Signalling rockets

Pleasure craft are obligated to carry 4 manual rockets with red light and 4 manual orange smoke signals as required.

Always verify the legislation of the Country in whose waters the yacht is going to navigate.

- The signalling rockets have a limited lifetime; it is therefore necessary to check their expiry date and eventually to replace them.
- The floating smoke signals, visible up to 4 km, have to be used with the daylight, to indicate the correct position.
- The red light rockets, visible up to 10 km, are designed for night use, but they can also be seen during the day.
- Before using the signalling rockets, always wait for the arrival of an air plane or to see people on the shore or on other crafts.
- Store the signalling rockets away from flammable liquids and from other fuels.
- As the content of the signalling rockets absorbs the moisture, make sure to have them located in a dry and accessible place.
- All people embarked must know the place of the signalling rockets and the method of use.
- Carefully follow the activation instruction for all signalling rockets.

**DANGER**

Keep the signalling rockets away from heat sources, such as flammable liquids or naked flames, and out of the reach of children.

**DANGER**

Once the signalling rocket has been lit, never direct it towards persons, there is a risk of burns and scalds.

**WARNING**

The signalling rockets have a limited lifetime, indicated on their containers. Once expired, contact the rockets suppliers which offer a disposal service. Do not light them unless necessary, because they can activate the Emergency Services.

3.1.4 First aid kit

The first aid box must be kept on board of class A crafts qualified for navigation“ with no limits from the coast”.

The container must be rigid, floating and with watertight closure.



ENVIRONMENT

It is forbidden to discard medicines at sea, even if expired. Treat medicines as special waste and therefore in accordance with the disposal procedures envisaged by the Country in which you are staying/ transiting.

This is the minimum quantity of medicines recommended for the Owner to keep on board:

- Disinfectant for external use;
- Ammonia;
- Bandages of various sizes;
- Plasters;
- Medicated plasters;
- Cotton wool;
- Scissors;
- Compressed hydrophilic gauze of various sizes;
- Compressed Vaseline gauze of various sizes;
- Tourniquet;
- Splints for fractures.



DANGER

Remember to check the expiry date and **availability** of the products contained in the first aid box at regular intervals.

Remember to store those medicines, which need to be kept in cool places in the fridge.

Inform all passengers of this.

Keep the first aid box in a place free from moisture and away from heat sources, easily accessible, quickly reachable in case of need and far from the reach of children.

3.1.5 Portable fire extinguishers

In order to supply an easy, ready and quick fire-fighting system on board your yacht, portable fire extinguishers have been set out, designed to be carried manually, and in compliance with the rules in force.

In case a fire breaks out, immediately reach a fire-fighting station where a portable fire extinguisher is located.

The use of a fire extinguisher requires a certain familiarity with it, but some theoretical-practical rules can facilitate its handling:

- Make sure that the safety pin (1) against accidental discharge, has been removed;
- Always direct the extinguisher towards the bottom of the flame;
- Do not stand but try to bow as far as possible;
- Do not hit the fire from above;
- Shift the fan-shaped jet slowly from one side to the other of the flame;
- Act immediately before the temperature becomes too high;
- Always stay windward;
- If the material burnt is wood, paper or tissue, after the fire has been extinguished, pour on water to prevent any further spread of flames;
- Always act dressed, avoiding loose clothing or similar;
- Head the yacht so that the fire is leeward;
- Persons not engaged with the fire fighting must gather windward from the fire area and if necessary, disembark on a rescue device (tender, rubber dinghy, self-inflatable life raft), that must be linked to the yacht with a line, in order also to embark the persons engaged with the fire fighting;
- If the fire is big the operators must abundantly wet their clothing;
- The engines must be shut-OFF immediately and the fuel must be cut-OFF;
- Isolated objects in flames must immediately be thrown overboard;
- All openings that can allow air to penetrate through the flames must be closed;
- After using the extinguisher to fight fire in closed spaces, ventilate the space carefully, prior to entry, and remove powder deposits.



**DANGER**

The person in charge of the yacht must make sure that all passengers know the locations and how to operate the fire extinguishers on board correctly.

The extinguisher should be kept in good condition and the charge indicator, located on the pressure gauge, must always be positioned in the green field. Keep the extinguishers in a vertical position.

After the use of a dry-chemical fire extinguisher, carefully clean the parts that came in contact with the powder because it is highly corrosive.

**WARNING**

We advise regularly checking the charge status (visual check of pressure gauge and weight) and also its overhauling, according to the rules in force in the country whose flag the yacht flies.

**WARNING**

For further information relevant to the use of the different systems and equipment, see the various manufacturers manuals, delivered separately.

**DANGER**

Pay particular attention during the cleaning and cooling operation because the components are still hot and can generate burns or scalds.

**DANGER**

CO₂ extinguisher uses CO₂ as an extinguishing medium it shall be used only to fight electric or galley fires.

The arrangement of the portable fire extinguishers is indicated in the diagram previously provided in chapter 3.1.1.

**CAUTION**

All fire extinguishers should be checked at least every 6 months by qualified staff and in any case after each navigation. Even after partial use, the extinguishers should be recharged by authorized personnel.

! WARNING

**THIS EXTINGUISHER USES CO₂
AS AN EXTINGUISHING MEDIUM
IT SHALL BE USED ONLY TO FIGHT
ELECTRIC OR GALLEY FIRES**

**TO AVOID ASPHYXIATION
AFTER DISCHARGE
LEAVE THE AREA IMMEDIATELY AND
VENTILATE BEFORE ENTERING**

3.1.6 Portable fire-extinguishers maintenance

Component	Maintenance	Notes and precautions
Portable fire extinguishers	Checks and tests	<p>Check the state of charge of each fire extinguisher at least once every 12 months, and in any case before each journey at sea, by means of the installed pressure gauge. The fire extinguisher is correctly charged when the weight value is as stated on the fire extinguisher's tag, and the charge indicator on the pressure gauge is in the green area.</p> <p>If they are found to be discharged or insufficiently charged, or at least every 10 years, have qualified technicians:</p> <ul style="list-style-type: none"> • Check the condition of the container (cylinder); • Refill the extinguishing medium; • Carry out a hydrostatic test. <p>Have fire extinguishers recharged even after partial use.</p> <div style="border: 1px solid black; padding: 5px; margin-top: 10px;"> <p style="text-align: center;">MAINTENANCE</p> <p>At least every 12 months, and, in any case, before each journey to sea, check the state of charge of the fire extinguisher.</p> <p>At least every 10 years, and in any case before each journey to sea, check the external state of the fire extinguisher.</p> <p>At least every 6 months check the fastening of the fire extinguisher.</p> </div>

3.1.7 Individual life jacket

The life jacket is an individual safety device, consisting of an orange jacket so that it is easily visible in water and resistant to the effects of sea water, hydrocarbons and low temperatures.

Besides, the individual life jacket is equipped with floating facilities consisting of foam blocks with closed cells, keeping their volume unchanged. They are also very resistant to sea water and to hydrocarbons and low temperatures. This kind of life jacket assures, by means of a suitable distribution of the floating material, the support of a body with the face out of water, apart from the position taken by the body when diving in the water.

These life jackets must be worn correctly and be firmly tied by means of strong laces.

It is important to learn, particularly for children, how to float in water with the life jacket.

To avoid energy waste it is necessary to float by keeping legs and arms folded as far as possible and tight to the body to maintain the heat.

The individual life jacket is equipped with an orange whistle, fastened to the jacket by means of a safety cord.

The whistle is particularly useful to indicate the wearer's position when the weather conditions do not allow sufficient visibility (bad weather, fog, etc..).

The individual life jacket has to be worn under following circumstances:

- When you navigate through sandbanks or tide reefs;
- At first sign of bad weather;
- When visibility is limited;
- When you navigate with rough sea;
- When you navigate alone;
- At any time with children below 10 years of age.



**CAUTION**

The yacht must be equipped with a number of individual life jackets equal to the number of people present on board. All people boarded must know the location of the life jackets, how to wear them, how to tie them properly to the body, and where the whistle is located.

**DANGER**

If you are to choose a life jacket for a child, take care about for the correct size and that smaller children do not slip out of them once in water. We recommend that all children wear an individual life jacket when they move on the yacht.

**CAUTION****CARING FOR AND INSPECTING THE LIFE JACKETS**

The life jackets must be handled with care so that they are able to save your lives whenever necessary. Check that all the belts, braces and buckles are in good condition and firmly secured on a regular basis. Make sure that all the seams are steadfast and that any welded or glued part adheres perfectly. Check that the reflecting strip, whistle and light are firmly secured and that the light battery has not yet expired.

MAINTENANCE

Wash in warm soapy water after use.

Dry thoroughly.

Store in a dry, ventilated area away from direct sunlight and harmful chemicals.

Check the life jacket regularly to make sure it is in good working condition.

**CAUTION**

Do not use life jackets as pillows.

Practice their use before you start navigating.

For people with disabilities may not be suitable.

With waterproof clothing or similar you can not reach the optimal use.

The use of life jackets does not guarantee total safety and the final rescue of the wearer, but it does support in water for a long period.

3.1.8 Life buoy

The life buoy is classified and resistant to sea water, to hydrocarbons, and to low temperatures; it is orange in order to be easily seen in water.

The life buoy is equipped with a lifeline of 30 m and with an automatic light buoy.

The life line is not twistable and it is orange in order to be easily seen in water.

**CAUTION**

All passengers must know the stowing place of life buoy.

**CAUTION**

The Captain must make sure that all passengers know how to use the life buoy:

- How and where to throw it;
- How to behave in case of “man overboard”.



3.1.9 VHF-Radiotelephone



The VHF device allows communication on channels dedicated to Port Authority, rescue and radio stations.

To ask for rescue it is necessary to use the suitable VHF/FM channel: after each hour, as a legal rule, follow 6 minutes of silence, from minute 0 to minute 3 and from minute 30 to minute 33, so as to enable better listening of the distress communications.

If the VHF is used, the distress call must be preceded and ended by the wording “**MAYDAY, MAYDAY, MAYDAY**”.

It is therefore necessary to give your position, the yacht’s name, the kind of damage and the kind of help you require (medical, mechanical, etc..).

**CAUTION**

Perform the “**MAYDAY**” rescue call, only in case of real need.

If, listening to the distress channel, a distress call that has not yet received an answer is picked up, it is possible to send a “**MAYDAY RELAY, MAYDAY RELAY, MAYDAY RELAY**”, forwarding the communication of the person who requested rescue.

It can in fact happen that the distress call, carried out on the open sea or by means of a poorly powered sender, is not received by the rescue team. Acting as a spokesman, you can help the message reach its destination successfully.

**CAUTION**

Perform the call “**MAYDAY RELAY**” only if there is a reasonable certainty that the message has not been collected by the rescue team so as not to engage the distress channel uselessly.

The use of the standard procedure avoids creating confusion and shortens the transmission time. In case of danger, use only the phonetic alphabet recommended.

The VHF device is a vital and important communication line; please remember some fundamental rules:

- No transmission should be performed without reason;
- Listen before transmission so as to avoid interference with other senders;
- For distress calls, use and hold the best possible wireless contact;
- Always use your call identification or the name of the yacht in order to make yourself identifiable. The use of names or family names is not al-

- lowed;
- Send short and clear messages;
- For distress calls it is important to give the yacht's position, the kind of danger, the time passed in water, the kind of yacht and the number of persons involved;
- For other calls, once the contact with the person called has been established, transfer the call on an operation channel;
- Cut out transmission if required by a coastal station;
- Retune the radio when the call is ended.

NOTE

For further information on use and maintenance, please refer to the manufacturer's manual.

MANUAL DISTRESS CALL:

- Select the distress channel by pressing key **16/9** or by scrolling the channels with the volume keys.
- Press the transmission key (**PTT**) on the radiotelephone and make the call.

MAYDAY - MAYDAY - MAYDAY THIS IS:

Repeat the yacht's name for 3 (three) times.

MAYDAY THIS IS:

Repeat the yacht's name.

AT POSITION:

Specify the position of the yacht.

SPECIFY THE DISTRESS CAUSE.

- Release the (PTT) transmission key.
- Wait for the reply for a few seconds.
- If you do not receive any reply, repeat the message at regular intervals, until receiving a reply.

- When you receive an answer, continue the conversation:
 - Hold down (PTT) while talking.
 - Release (PTT) while listening.
- It may be required to switch to a working channel.

AUTOMATIC DISTRESS CALL:

- Lift the cover and press the **DIST** key; the display will show the wording "Distress call Undefined".
- Hold **DIST** for about 3 seconds, then displays the message: "**DISTRESS CALL SENDING**" and the radio beeps acoustic alarm.
- The distress message will be sent automatically and repeated at irregular intervals on Channel 70. Channel 16 will be available for communication after each transmission.
- If you receive no response after a short time, try to send the distress message manually.

**WARNING**

After the automatic SOS has been activated, it must be turned OFF by pressing the ON/C, otherwise the help message continues to be transmitted. The SOS function is automatically locked until the number of DSC has been entered. Consult the manual provided by the manufacturer for the correct entry operations.

- You can press ▲ or ▼ to scroll through the transmitted Distress call information.
- You now have the following soft-key options:

RESEND

Displays "**HOLD DISTRESS 3 SECONDS TO SEND**". You can then:

- Hold down the red "**DISTRESS**" key for 3 seconds to resend the call, or
- Press the "**EXIT**" soft key to return to waiting for an acknowledgement.

PAUSE

Pauses the call repeat mode. You can then:

- Press the **“EXIT”** soft key to resume the same call.

CANCEL

Displays **“DISTRESS CALL SEND CANCEL.”** You can then:

- Press the **“NO”** soft key to send the **DISTRESS CANCEL** signal.
- Press the **“YES”** software button to send the “Distress Cancel” signal;
- Press **“PTT”** and report your situation using the handset.
- When finished talking, press **“X”** to return to standby mode.
- After receiving confirmation, press the **“SILENCE”** software button;
- Press **“X”** to exit the current emergency acknowledgement.

This device can be equipped with the Automatic Identification System (AIS) which allows to identify and locate other boats by electronically exchanging data with them.

3.1.10 EPIRB

It is a distress transmitter whose purpose is to signal the position of boats and ships in serious emergency situations.

It essentially consists of a radio transmitter that interfaces with the satellite system for search and rescue operations.

When in use, the EPIRB emits signals on emergency frequencies that are picked up by the network of satellites in orbit and transmitted back to the ground at the rescue coordination centres.

The correct procedure for activating the EPIRB is as follows:

- When abandoning the yacht, take the EPIRB and place it on the life raft;
- Untie the line attached to the device and secure it to the life raft;
- Activate it according to the model;
- The EPIRB will start flashing;
- Make sure that there are no obstacles in the sky so that the signal reaches the satellites.

3.1.11 Emergency boarding system

When in the water and in the event of an emergency or a fall, the boarding aid, consisting of a grab bar and a “ladder” in the centre of the stern platform, can be used to get back on board the yacht safely and easily.

To do this, unlock the “ladder” and move it until it is in a vertical position.



WARNING

The emergency boarding system is a safety feature and should only be used in case of emergency.



DANGER

It is the captain responsibility, when the yacht is not underway but manned, to ensure that it is possible to re-board by making the emergency boarding system available.



3.2 YACHT'S AREAS

The diagram below, represents the yacht's general layouts, divided according to the areas they include:

1. Flying bridge sunshade
2. Flying bridge
3. Helm station
4. Forward sun deck
5. Platform area
6. Garage hatch/beach area
7. Stern cockpit
8. Lounge
9. Dining room
10. Master cabin
11. Galley
12. Engine room
13. Port-side VIP cabin
14. Starboard VIP cabin
15. Starboard guest cabin
16. Port-side guest cabin
17. Captain's cabin
18. Port-side crew cabin
19. Starboard crew cabin
20. Garage

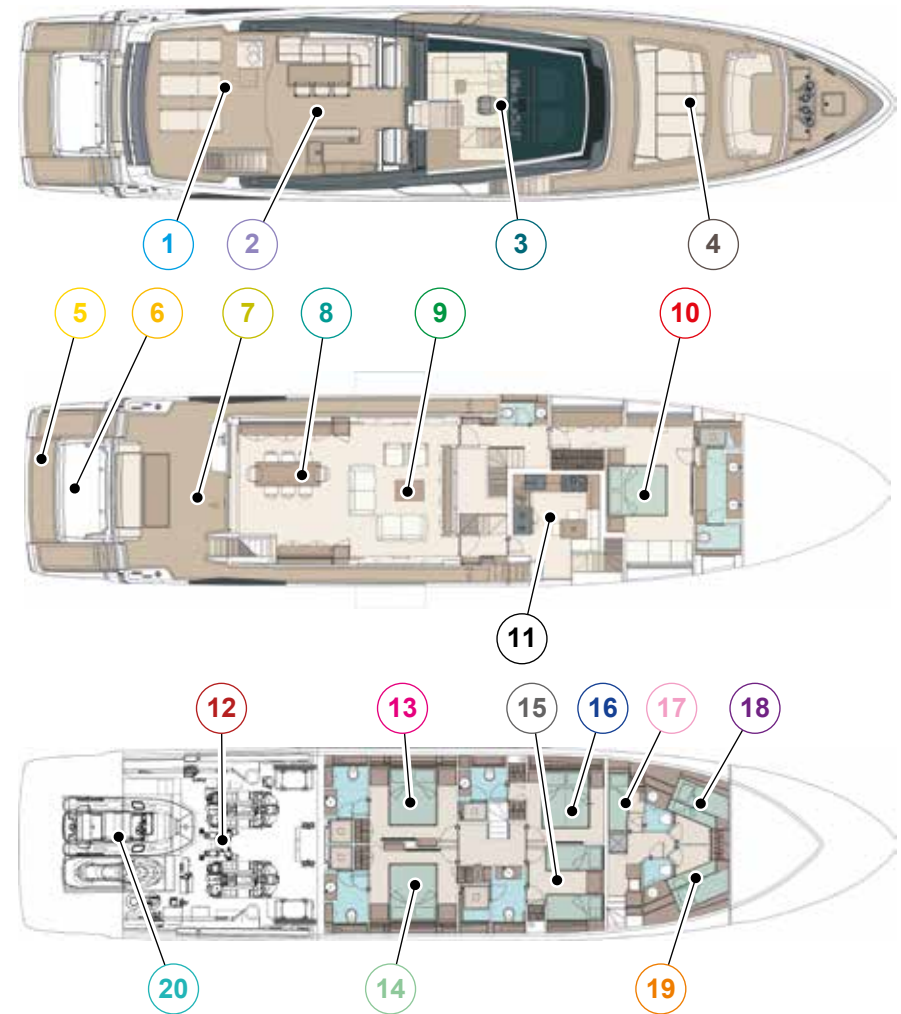

3.3 ESCAPE ROUTES

In order to deal with the different emergency situations that could require the abandonment of the yacht (fire, collision with sinking hazard etc..) in the quickest and safest way, the rules in force require an “escape plan” informing about the safest and most secure, as well as the quickest, paths (from any yacht area) for taking shelter and reaching the “muster stations”, outdoors, from which it will be easier to leave the yacht.

**WARNING**

Always keep the escape routes, dry, free and accessible.

**DANGER**

The various yacht's areas have more than one escape route. It is therefore necessary, according to the nature and position of the danger or fire source, to choose the safest and most suitable escape route very carefully.

**DANGER**

For safety reasons, the engine room access door, in any case and occasions, must be kept closed. It must remain open only during the crossing.

**WARNING**

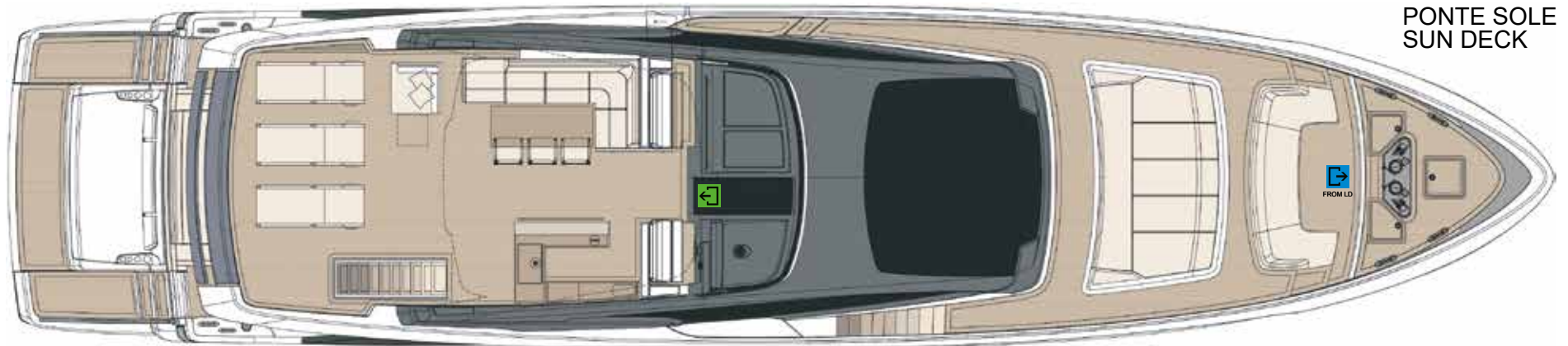

The ladders must be carefully used during navigation.

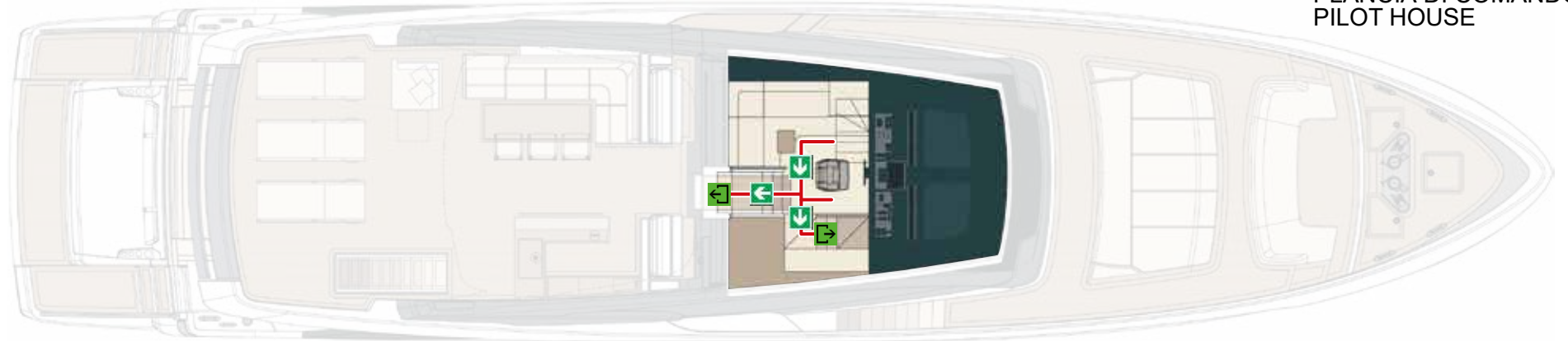

PONTE SOLE
SUN DECK



PLANCIA DI COMANDO
PILOT HOUSE

-  Via di fuga
Escape route
-  Sfuggita
Escape
-  Sfuggita secondaria
Secondary escape

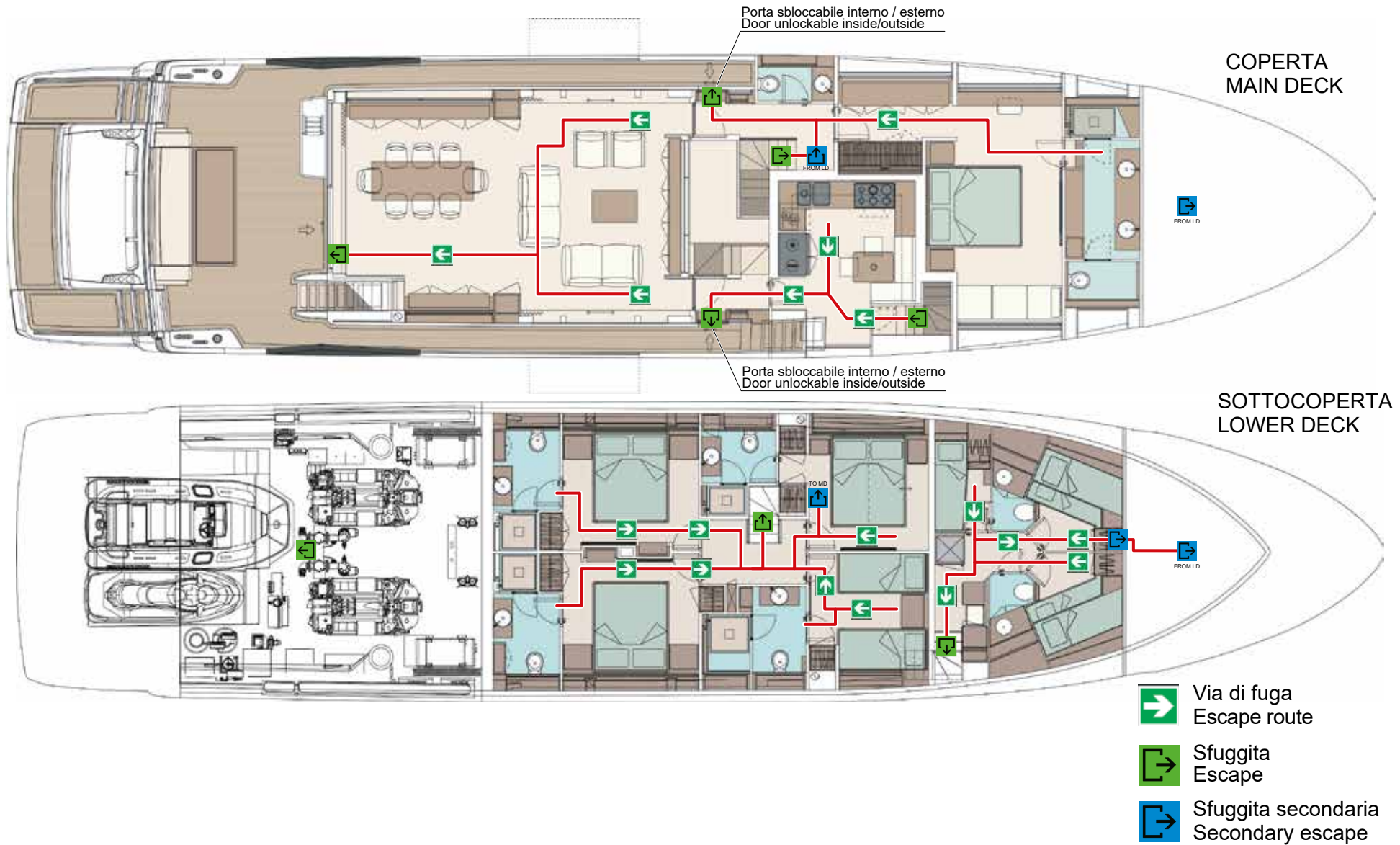

3.3.1 External areas forbidden during navigation, with restricted access

Red Area (forbidden)
Areas that cannot be used during navigation.

3.3.2 External areas accessible with care during navigation

Green Area (free-working deck)
Deck areas for normal transit or stopping when navigation and sea conditions so allow.

Cleats
As hooking points.

Stanchion
As hooking points.

 **WARNING**

Control and verification of compliance with safety requirements is a responsibility of the yacht Captain.



**CAUTION**

All the areas where there is polished fibreglass are no-step areas.

**DANGER**

Unidentified external areas of the yacht: access to these areas is FORBIDDEN. Only professional personnel, under their own responsibility, can gain access to them when the yacht is moored in a safe harbour or in a lay-up shipyard if they are wearing shoes with non-slip sole and belt/safety equipment tied to a safe point of the yacht to prevent falling.

**DANGER**

On board the yacht, some areas are “dangerous”, and need plenty of care, and possibly require wearing protective equipment, in order to safeguard the integrity of people on board. During navigation, the risks relating to any hazardous area increase significantly; we recommend, therefore, scrupulously observing the safety rules indicated in this manual.

The areas are following:

- **Engine room:** area with a high level of noise, presence of moving components, burns hazard, tripping and falling hazard. The access to the engine room is exclusively allowed to trained and expert crew, prepared for the risks and equipped with proper safety devices.
- **Flying bridge:** outer area with protections against falls with reduced height and extension. Therefore be extremely careful when leaning out during the manoeuvres of the yacht and during navigation, especially with rough sea.

3 - SAFETY DEVICES AND EQUIPMENT

- **Stern platform:** outer area not protected by rails against the fall at sea. During navigation access to this area is forbidden. Accessing and staying in this area is allowed only when the yacht is idle and with the engines shut OFF.

In case of a fall overboard, the following rescue devices can be used:

- Life buoy;
- Individual life jackets.
- Swim Ladder with non-assisted re-boarding.

The easiest way to get on board is from the stern platform by means of the swim ladder, which is stowed inside the stern platform when not in use.

**CAUTION**

It is the captain responsibility, whenever the yacht is NON-OPERATIONAL (i.e. not navigating) BUT MANNED, to ensure the possibility of re-entry on board by positioning the manual swim ladder.

Hooking points:

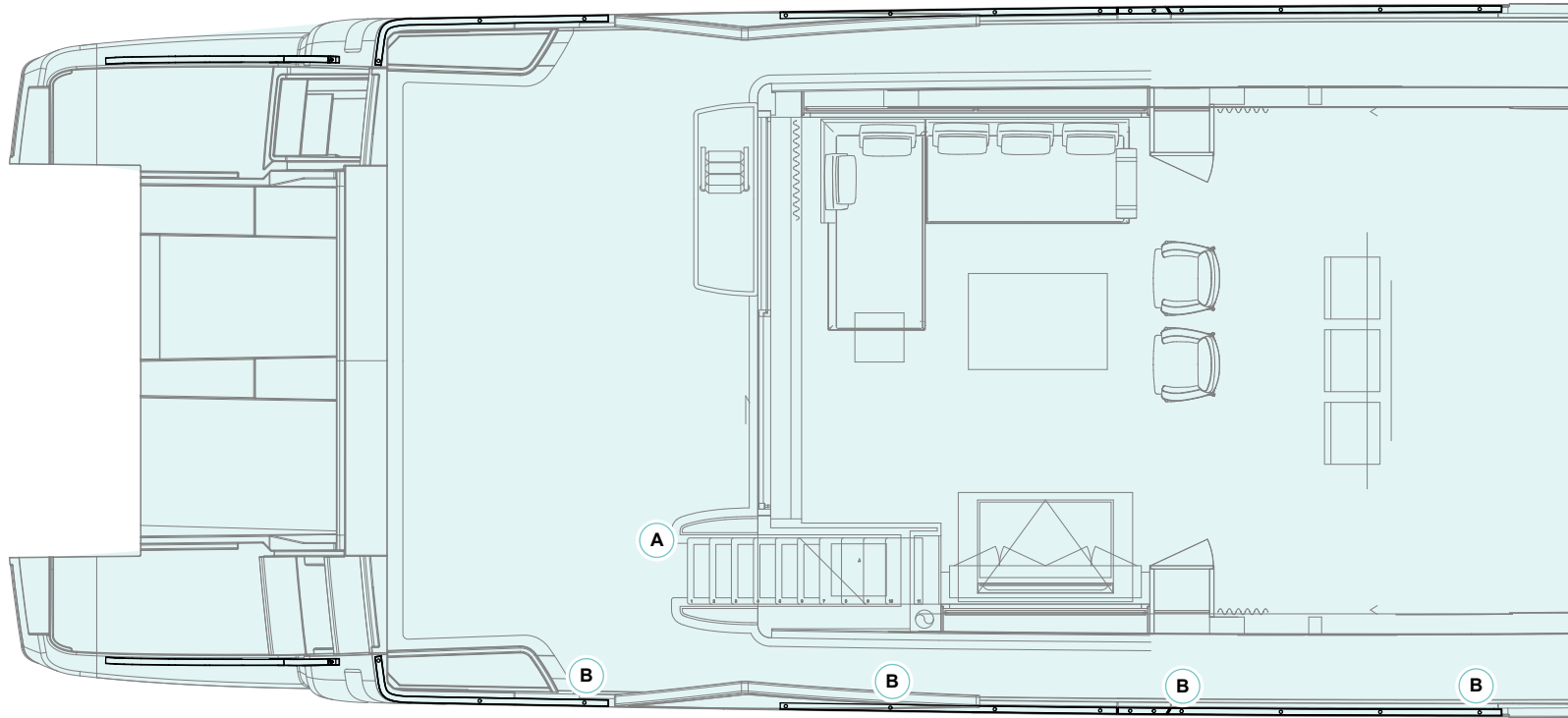

ICONA ICON	DESCRIZIONE DESCRIPTION
A	Anello abbattibile acciaio inox Padeye stainless steel ring
B	Anello saldato alla base del candeliere Ring welded to the support base

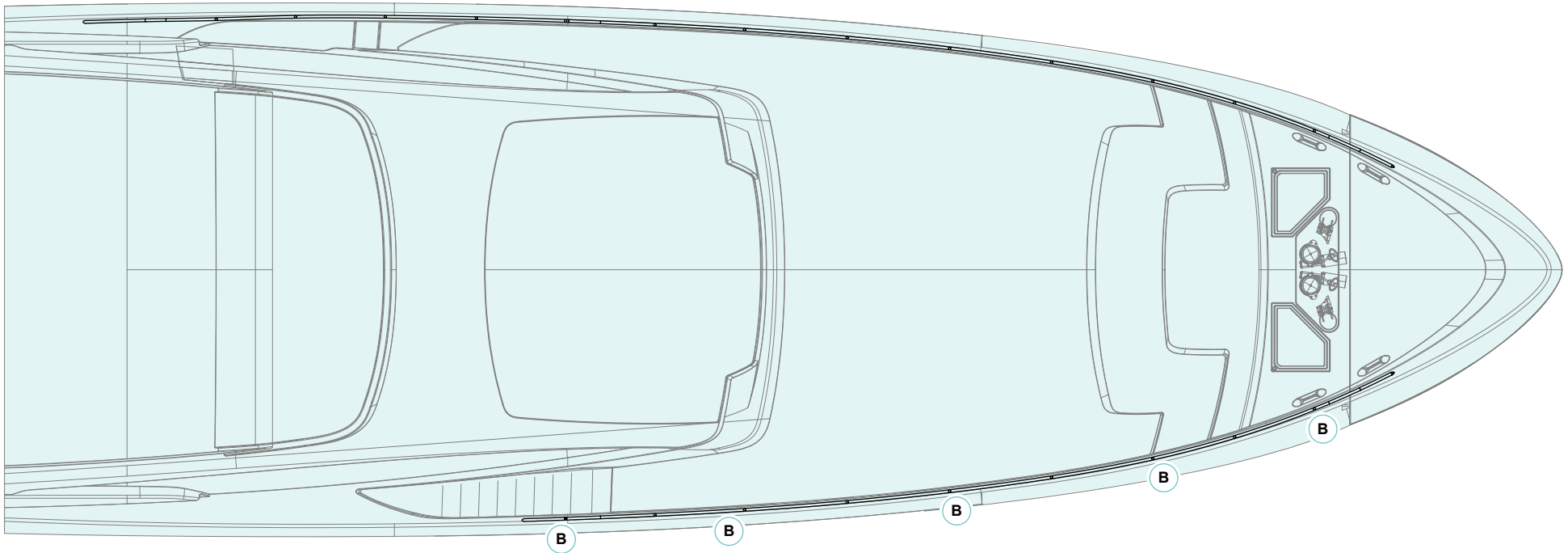

ICONA ICON	DESCRIZIONE DESCRIPTION
A	Anello abbattibile acciaio inox Padeye stainless steel ring
B	Anello saldato alla base del candeliere Ring welded to the support base

3.4 ALARM DEVICES

The alarm devices include a smoke detection unit, a flashing signal unit with alarm siren.

These devices activate in case of smoke detected by sensors located in the engine room, and, if provided by those located in the rooms, galley, salon and corridors.

You can monitor the presence of smoke in the yacht also from the panel touch screen present on the dashboard.

MAINTENANCE

At least every month carry out an operation test.



3.4.1 Alarm system for high water in the bilge

An alarm siren is provided to warn against a high water level in the bilge, operated by floating switches located in the various compartments of the bilge on board.

The alarm is on the monitoring system in the main and fly helm stations by means of an acoustic signal.

MAINTENANCE

At least once a week check the operation of the floating switches and of the siren.

At least once a month clean the floating switches.



CAUTION

To prevent false alarms, make sure that the system is isolated and disabled before performing maintenance and cleaning of the smoke detectors. Once the periodic maintenance of all detectors, supply and rehabilitate the system.



CAUTION

For more information about the various devices installed on the yacht, refer to the use and maintenance manuals delivered separately by the Manufacturer.

3.4.2 Smoke detection control unit

Designed and built in compliance with the regulations in force, the fire detection control unit is capable of identifying anomalous situations and distinguishing them with diverse signals: alarm, pre-alarm, fault, warning, exclusion, test, monitor. All reports are visible both on display and on both LEDs.

The control panel has a number of areas which can be connected to the detectors.

Each detection unit is equipped with its own output of alarm repetition, allowing the alarm to be repeated on the monitoring system.

The smoke control unit and the light/siren signal group, equipped with a buffer battery, are suitable to signal the danger even in conditions of a complete power failure.

If the main 24V power supply of the control unit should fail, the malfunction is indicated visually (alarm warning light) on its control panel.

If both power supplies (main and buffer battery) should fail, the control unit activates the smoke alarm siren.

NOTE

For further information on use and maintenance, please refer to the manufacturer's manual.



CAUTION

The control unit has been set and tested by RIVA; do not alter the programming controls. Contact RIVA After Sales & Service Department.

**CAUTION**

In case the accumulator of the smoke detection unit is discharged, the siren starts automatically.

Use of the smoke control unit and of the signal light/ acoustic alarm unit:

The batteries fitted to these units are maintenance free, they do not need to be filled with distilled water.

Keep the terminals on the battery top clean at all times to prevent the battery discharge. Check the battery terminals, they should not be loose and must not have any sign of rust or oxidation.

Apply some Vaseline on the terminals to prevent their corrosion.

**ENVIRONMENT**

Handle and dispose of batteries according to the rules in force. Use only authorised disposal procedures. In case of doubts, contact the Port Authority.

Description	Cells number	Features element
Smoke control unit battery	2	12V 7Ah
Signals unit battery	1	12V 2.1Ah

**WARNING**

If possible, keep spare batteries on board.



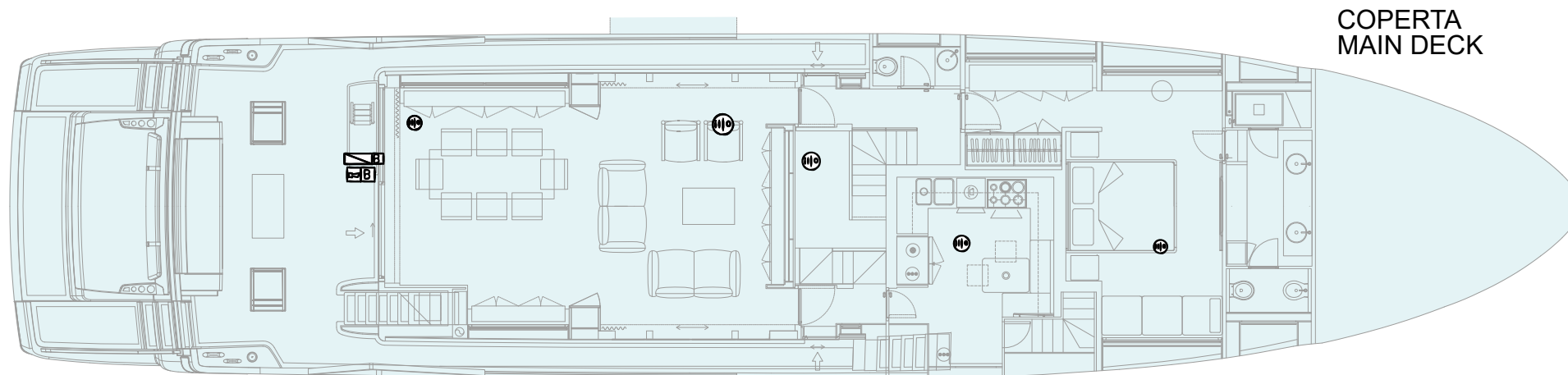

Fire detection diagram:

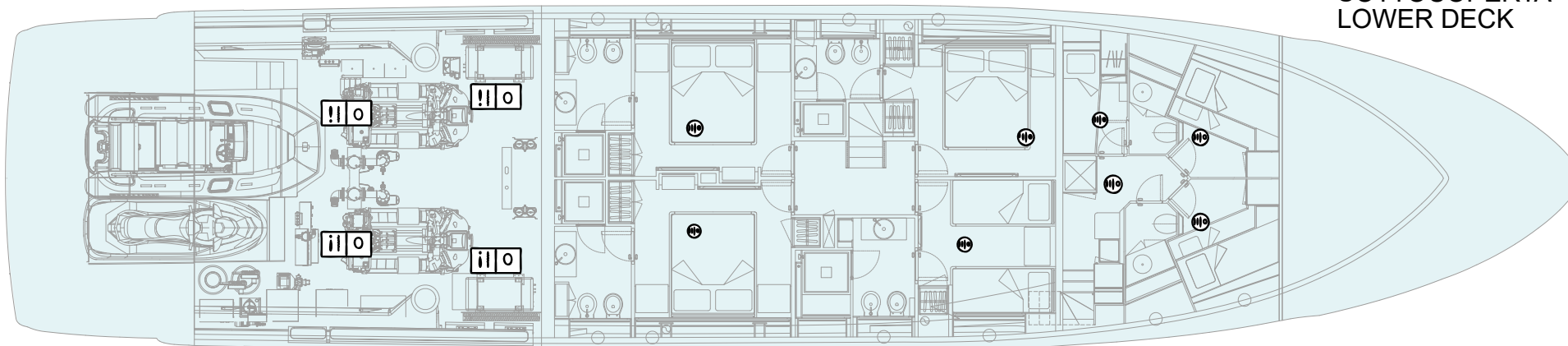

COPERTA
MAIN DECK



SOTTOCOPERTA
LOWER DECK

-  Centralina fumo
Smoke control unit
-  Sirena autoalimentata
Self-powered buzzer
-  Rilevatore di fumo
Smoke detector
-  Rilevatore di fumo
Smoke detector

3.5 ENGINE ROOM FIRE-FIGHTING SYSTEM

The engine room is protected by its own fire-fighting system, with automatic or manual activation, which uses type NOVEC gas as extinguishing agent. The cylinder is installed on the bow bulkhead of the engine room.

The discharge is automatically activated by means of a glass flask filled with liquid; when the temperature rises, the liquid expands until the flask breaks, and the extinguisher discharge activates.

The vial is mounted on the cylinder itself. The extinguisher can also be activated manually; the discharge is controlled by the tie rod located in the fire station in the left cabinet of the stern cockpit next to the descent into the engine room.

The system is equipped with a control unit which in case of discharge, automatically stops the engines, the generators and the extractors in the engine room.

In the main helm station there is a panel for the control of the fire fighting system, described hereunder:

1. Green light

Indicates that the extinguisher is full.

2. Red light

Indicates that the extinguisher is empty.

3. SILENCE button

It turns off the acoustic signal which indicates that the system is operating and that the extinguisher is releasing gas.

4. DIMMER

It varies the brightness of the control lights of the CHARGE/ OVERRIDE panel.

5. OVERRIDE button

- When this button is pressed, the control unit which, in case of extinguisher discharge, stops the engines, generators and electric extractors, is cut OFF.
- In OVERRIDE position the control unit is disabled.

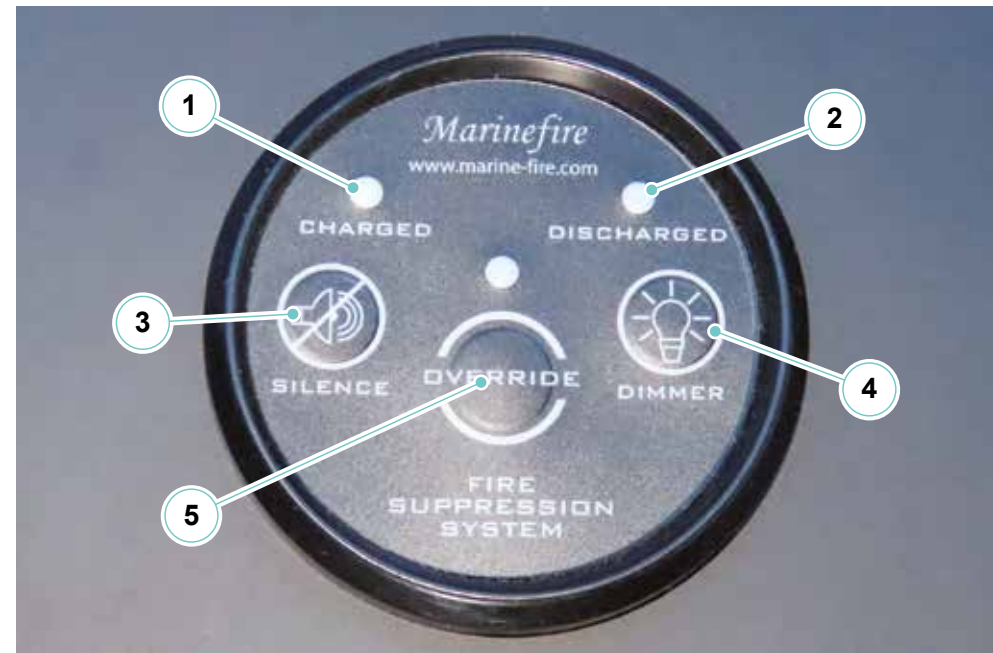

**WARNING**

The OVERRIDE button must be pressed only when navigating in confined waters or with a collision hazard and to restart the engines after the system's discharge.

**CAUTION**

The OVERRIDE button must only be used in case of real emergency.

**CAUTION**

The engine room is equipped with fixed fighting system. To avoid asphyxia, leave the area before the system's discharge. After discharge, ventilate the area before entering.

Fixed fire-fighting system diagram:

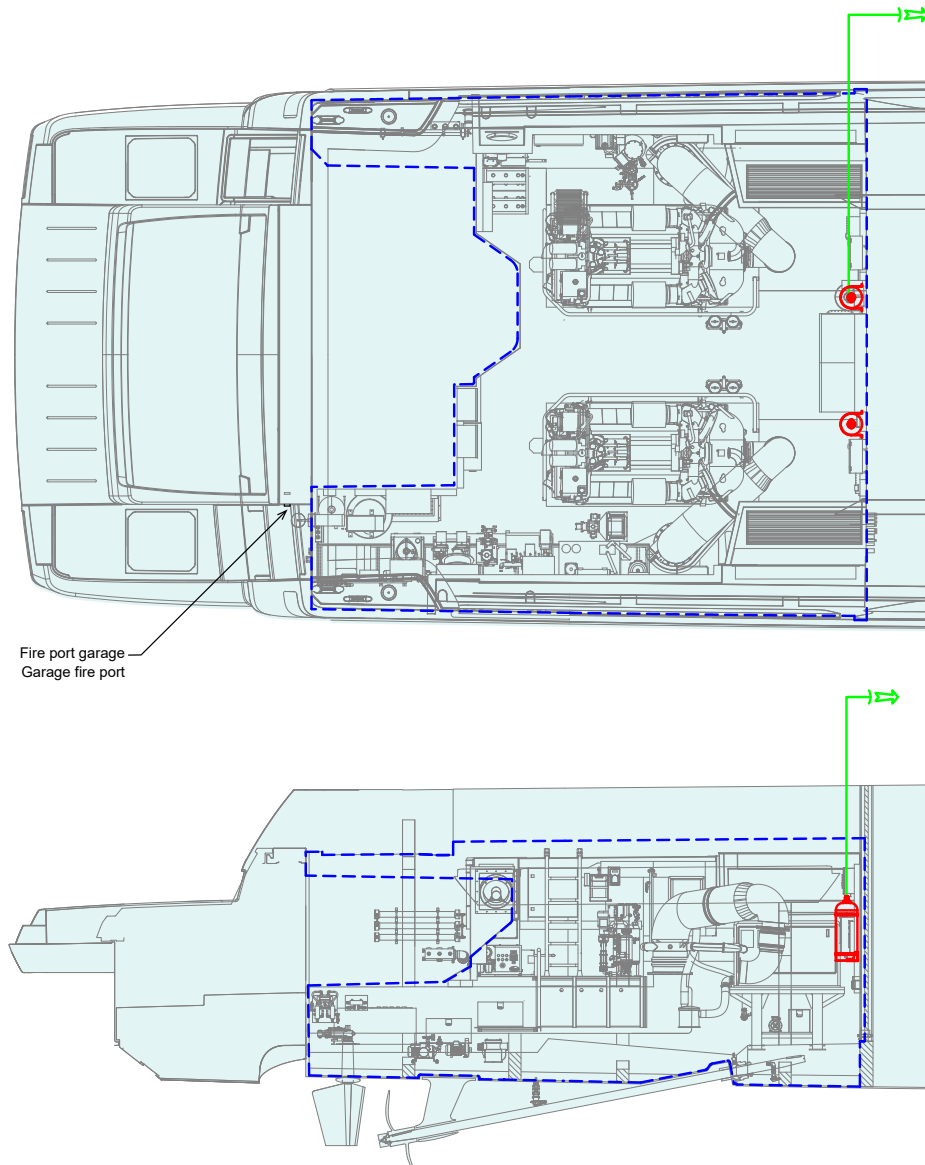

ICONA ICON	DESCRIZIONE DESCRIPTION
---	Area antincendio sala macchine Engine room fire-fighting area
	Sistema MA 960-1350 Azionamento automatico + manuale da postazione antincendio sul ponte di coperta MA 960-1350 system Automatic + manual activation from fire-fighting station on main deck

3.5.1 Fire-fighting system operation

The fixed fire-fighting system operates automatically when the temperature in the engine room exceeds 79°C. The discharge is driven by an automatic system consisting of a glass flask filled with liquid and installed on the extinguisher cylinder.

When the temperature around the flask reaches the preset level, the liquid expands until the flask breaks and the extinguisher activates. The system can also be activated manually. The tie rod for manual activation is located on the engine room access ladder.

By pulling the tie rod, the system stops the engines, the generators and the electric extractors automatically.

A panel located in the main helm station on the main deck to allow extinguisher discharge monitoring.

In case of fire in the engine room, operate as follows:

- Shut down both engines and generators, if running, by means of push buttons in the helm stations;
- Turn OFF the battery breakers and all magneto-thermal switches of the AC;
- From the fire-fighting panel, located in the engine room access ladder, remove the pin by slipping it off;
- Pull tie rod safety for extinguisher discharge. The extinguisher can be automatically discharged, but pull the tie rod anyway.



CAUTION

If the fire breaks out underway, perform the distress call "**MAY DAY**"; if the yacht is in the harbour, advise the Port Authority and evacuate all unnecessary personnel.



CAUTION

Do not delay fire fighting because of a rescue call.



CAUTION

To shut OFF the engines, do not only push the stop buttons but also always turn the keys.



CAUTION

Keep the fire fighting control tie rods efficient; service them and check for their operation at regular intervals (as per rules in force).



CAUTION

Before setting up for navigation, it is necessary to open the lock and to have the crew access free and the fire-fighting control panel as well. Check that the safety pin of the cylinders has been removed.



DANGER

The automatic fire-fighting system, covering exclusively the engine room, under special fire conditions could not activate, for this reason **IT IS ALWAYS COMPULSORY TO ACTIVATE THE SAFETY TIE ROD.**

**WARNING**

When operating the fire extinguishing system, disconnect the engine room extractors and close the air intakes. Once the fire is extinguished, ventilate the room for a long time before going inside without activating the extractors.

**CAUTION**

The automatic system is calibrated to detect the fire when they reach 79°C, therefore, if a beginning of a fire is found, it is absolutely necessary to actuate manually the system in order to limit damage to a minimum.

3.5.2 Fire-fighting system control tie rod

The fire extinguisher control rod controls the automatic discharge of the fire extinguisher in the engine room and excludes the electrical system of engines, generators and extractors.



WARNING

Do not open the engine room access hatch, until the fire is completely extinguished.



DANGER

Before activating the fire-fighting system, make sure nobody is inside the engine room. Once checked that the fire is totally extinguished, before entering the room, ventilate it for a long time by opening the hatches, and remove any powder NOVEC deposits carefully.



DANGER

The automatic fire extinguishing system does not block the possible escape of oil, only suitable tie-rods are able to block this. Always apply the tie rods "FUEL" in the event of a discharge.



**DANGER**

The chemical agents for extinguishing fires and the residues of a discharge system are toxic. To avoid diseases, injuries or death caused by the breathing of fumes, make sure that nobody stays in the engine room during the system discharge.

**DANGER**

The fire extinguisher cylinder has a safety pin. Check that the aforementioned pin has actually been removed. If this were not the case, in the event of a fire, the fire extinguisher would be blocked and would not discharge with the possibility of major damage to your yacht up to and including sinking.

**DANGER**

The safety pin inserted prevents the activation of the manual release (by means of tie rod).

**WARNING**

An automatic fire-fighting system can cause fire to spread out again. If fire spreads again, the passengers on board are in danger. Even the opening of the engine room access hatch can cause through oxygen a new fire spread. If fire spreads out again, to avoid heavy injuries or even death, do not open the hatch or engine room access door until the fire has been completely extinguished.

**WARNING**

Before entering the engine room after a fire, make sure that this has been completely extinguished. Before entering this room ventilate it by opening the hatchways.

3.5.3 Maintenance of fixed fire-fighting systems

- Have the system overhauled by a qualified service centre according to the manufacturer's instructions. The technician who performs maintenance should attach a tag indicating the date of the check to the system.
- Check the discharge indicator before use, to make sure that the fixed fire-fighting system has not been discharged.
- The fixed fire-fighting systems must be checked at least once a month and in any case, before each navigation.
 - a. For corrosion.
 - b. To make sure that the access to the controls is not blocked.
 - c. To make sure that the cylinders are firmly sitting.
 - d. To make sure that the pulling cables are not broken, loose, damaged or twisted.
 - e. To make sure that the cable connections are fastened properly.
 - f. To make sure that the distribution pipe connections are firmly fastened and that the discharge nozzles are not blocked.
 - g. To make sure that the system has not discharged.

**CAUTION**

Accidental discharge of the chemical agents for fire extinguishing during handling or installation may cause serious injuries. The chemical agents for extinguishing fires and the residues of a discharge system are toxic. Protect eyes and skin during installation or maintenance of the fire-fighting systems.

**CAUTION**

The extinguisher CONTAINS TOXIC CONCENTRATED CHEMICAL AGENTS AND SUB PRODUCTS FOR FIRE FIGHTING. Avoid inhaling fumes or long exposure to them. THE ACCIDENTAL DISCHARGE DURING USE OR INSTALLATION CAN CAUSE SERIOUS INJURIES. Never let it drop down. Keep it far from extreme heat.

**CAUTION**

Carefully read the instruction manual before attempting any installation, removal, activation or maintenance of this device.

**CAUTION**

During maintenance operations, pay attention not to break the flasks unintentionally, in order to prevent accidental cylinder releases.

**CAUTION**

Check that at environment temperature the cylinders pressure gauge is set to correct actuation position indicated by the supplier.

3.5.4 Restoring the fire-fighting system in the engine room

If the fire-fighting system of the engine room has been activated and a fire has been extinguished, it is necessary to restore the essential conditions for navigation, in order to quickly reach the nearest harbour in which to carry out the due checks.

To resume navigation, the ventilation system of the engine room and the fuel system of the propulsion engines must be brought back to normal working condition.



DANGER

Before entering the engine room, ventilate the room properly, to avoid risks due to high temperatures and noxious gases suspended in the air.



DANGER

These operations have to be carried out directly from the engine room; therefore before carrying out any operation, carefully read the safety instructions in this Manual.



DANGER

Resetting the fire-fighting system, with the aim of resuming navigation is a recommended operation only in case the fire source has not caused damage to the yacht's structure or to important devices of the same.

In such a case, or should you have any doubt, it is essential, to wait for rescue without resuming navigation.



WARNING

Remember that, as a result of the fire-fighting system reset, the NOVEC extinguisher will be discharged and will be inefficient in case of another fire break out. Therefore, once returned to the harbour, you must have the fire extinguishers immediately recharged by authorised personnel.

To allow the starting of the propulsion engines, it is necessary to manually activate the engine supply valves, located on the fuel tank in the engine room.

For this purpose, it is necessary to open the fuel delivery valves, previously closed by the fire-fighting handle for fuel cut-OFF, by turning them anticlockwise.

The fuel cut-OFF valves are not to be left in intermediate positions but they must be completely open, when the red handle is parallel to the longitudinal axis of the piping.

3.5.5 Fire-fighting system in the engine room

To make sure that the fire extinguisher is operational, the pressure gauge must be in the green field.



CAUTION

Accidental discharge during handling or installation may cause serious injury. Re-insert the safety pin fitted by the Manufacturer on the sensing/detecting valve of the cylinder up to complete and controlled installation. Protect eyes during installation or maintenance.



WARNING

During maintenance operations, pay attention not to break the flask located on the cylinder, because, even if the safety pin is inserted, if the flask breaks, the fire-fighting system activates.

MAINTENANCE

At least once a month, and in any case, before each navigation, check the charge status of the fire extinguisher.

At least once a month, and anyway before each navigation, check the external condition of the fire extinguisher.

At least every 6 months check the fastening of the fire extinguisher.

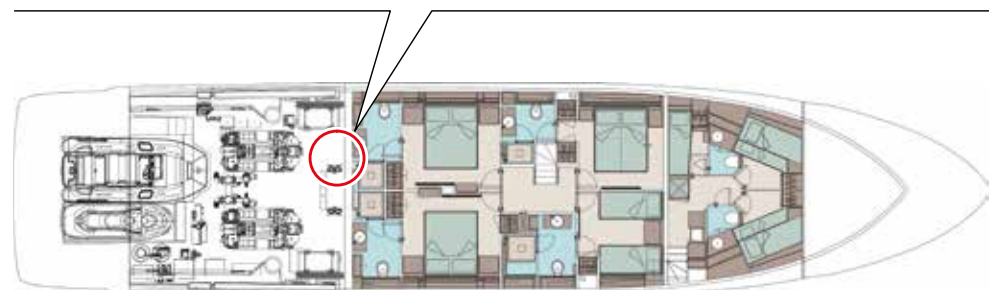

3.5.6 General information to prevent fire

Regular and correct maintenance of the systems and prudent behaviour of all passengers are indispensable measures for preventing any risk of fire.

Over 90% of the probabilities of fighting a fire successfully, depends on the ability to prevent and avoid any condition that may help a fire to spread. The small remaining percentage depends on the crew's reaction ability, and most of all, their rapidity to enter into action.

Nearly all fires, if detected early, can be extinguished easily. For these reasons, it is necessary to carry out preventive surveys on a regular basis and identify all possible fire sources, and in particular:

- Check the proper operation of all main equipment/systems;
- Visit all compartments and in particular the engine room frequently;
- If a system does not work correctly, identify the failure and take the appropriate corrective actions;
- Operate all systems and equipment as specified.

If a fire is detected, identify and remove the cause, if possible, (e.g. in case of a short-circuit, cut-OFF the electrical system), extinguish the fire promptly and be vigilant to make sure that the fire does not break out again.



WARNING

Never use water jets to extinguish fires on electric or electronic equipment.



CAUTION

The ability to operate the fire extinguishers properly can ensure the success of the operation.

It is vital that the fire fighting operations are performed by people competent in this type of emergencies.

It is in any case necessary to be aware of the minimum fire-prevention and fire-fighting rules; the first defence is to prevent fires before they start spreading.

The following table contains the classification of the fire types:

Comparison between fire classes

American	Europe/Australia/ Asia	Fuel/Heat source
Class A	Class A	Ordinary fuels
Class B	Class B	Flammable liquids
	Class C	Flammable gases
Class C	Class E	Electric appliances
Class D	Class D	Combustible metals
Class K	Class F	Cooking oil or fat

It is very important to use the correct extinguishing agent according to each fire class; normally, water can be used only for class A fires, together with chemical extinguishing agents (portable or fixed devices).



Riva

102 CORSAIRO *supera*

Each yacht owner/operator/skipper must be well informed and proficient regarding the measures to be adopted in the event of a fire and the applicable fire-extinguishing methods.

3.6 GARAGE FIRE-FIGHTING SYSTEM

The garage is protected by its own manually activated fire-fighting system. The system allows to extinguish a fire in the garage without having to enter.

The system is composed of:

- A powder fire extinguisher 6 kg, placed in the aft compartment of the starboard ladder;
- Potentially an additional 6 kg powder extinguisher placed in the port-side compartment of the stern cockpit;
- An opening (fire-port).

The fire port is located near the first step of the starboard ladder to access on the stern platform. To activate the discharge you need to break the glass present in the "FIRE-PORT" protection, insert the nozzle of the extinguisher and activate.



DANGER

Chemical elements to put out fires and debris of a discharge system are toxic. To prevent illness, injury or death caused by the inhalation of fumes, make sure that nobody is on the premises during discharge system.

MAINTENANCE

At least monthly, and before each sea trip, check the state of charge of the extinguisher.

At least monthly, and before each sea trip, check the external condition of the extinguisher.

At least every 6 months to check mounting extinguisher.



3.6.1 Garage ventilation system diagram

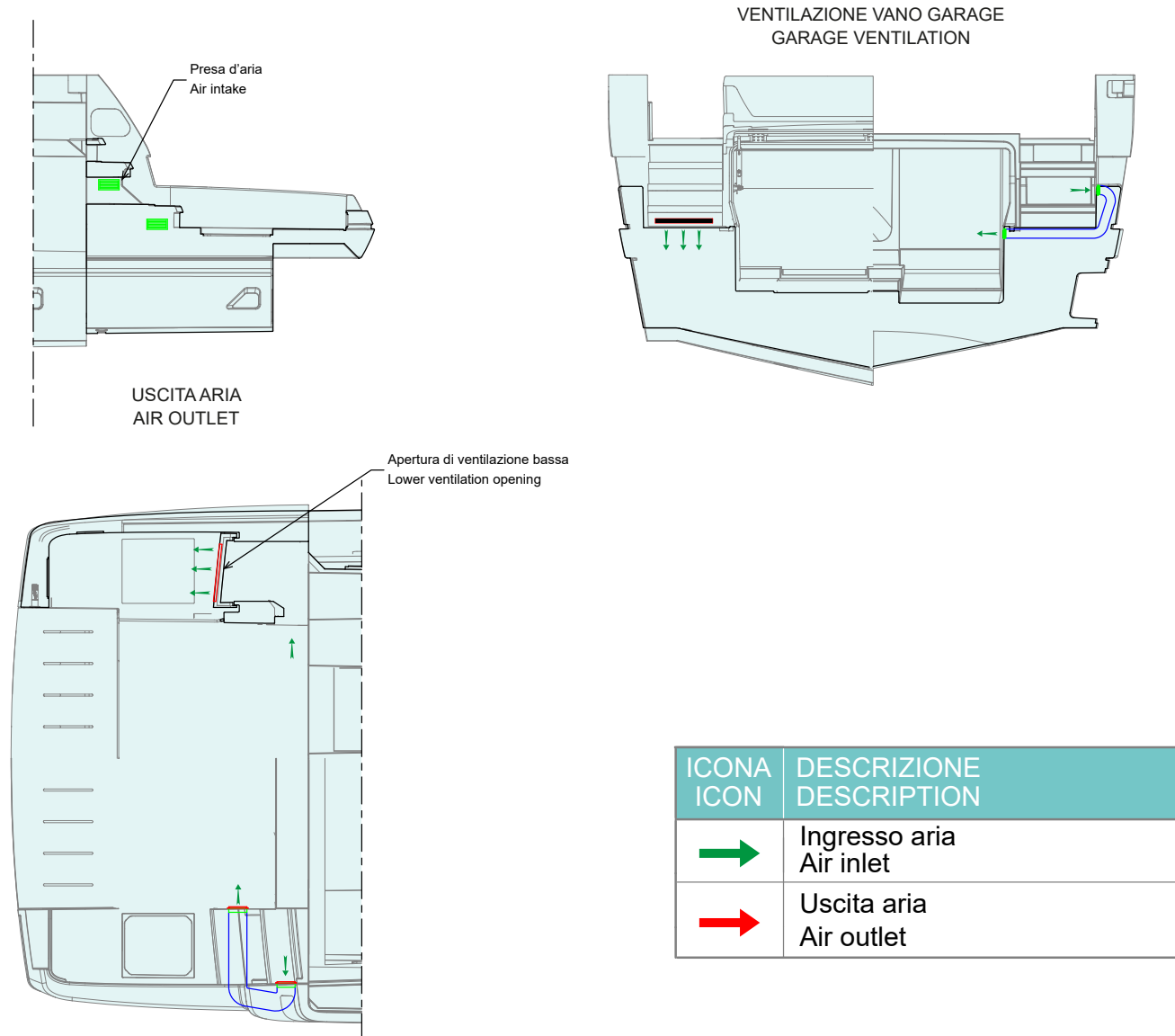

3.7 LOCATION OF SAFETY PLATES

The plates applied on the yacht are used to point out special risks: each plate is located on the part of the yacht which can be a source of risk. Before working with or on this part of the yacht, read the safety warning carefully.

Keep all the plates clean and readable, replace them if missing or damaged.

The fire extinguisher plate is located adjacent to each fire extinguisher.

**CAUTION**

It is forbidden to remove the plates attached to the yacht.

3.8 MANDATORY SAFETY EQUIPMENT

In order to ensure the maintenance of the intrinsic safety conditions of the yacht, the Owner must keep the yacht in good operational conditions (as regards the hull, and the propulsion, electrical and fire-fighting systems), and also to provide for the replacement of any system, rescue and safety equipment showing signs of wear or deficiencies capable of impairing their efficiency.

In addition to the equipment provided by RIVA, the Owner is responsible for providing the yacht with any further system and safety/marine equipment required by the rules in force in the nation where the yacht is used, according to weather and sea conditions and to the distance from safe harbours along the intended course.



DANGER

Rescue equipment must be arranged so as that when it is launched there are no obstacles to free floating and must be equipped with proper fitting allowing for quick release from the yacht when navigation.

The Owner is responsible for equipping the yacht with some of the equipment listed.



WARNING

The above-mentioned safety systems must comply with existing local and international navigation regulations, and must be periodically inspected and maintained by specialized companies and qualified technical personnel, prior to the expiry date indicated on the systems.



CAUTION

Refer to the local Port Authorities for instructions and changes of the Safety Rules in force in the country where you are.

3.9 ITEMS USEFUL TO HAVE ON BOARD

In addition to the standard safety and marine equipment, required by the existing regulations for leisure crafts, we recommend keeping on board a number of items (not included in the standard equipment), that can be useful when operating the yacht; most probably, these items will not be used frequently, but may be determining for the navigation safety and continuity, in case of failures:

- 2 lines, Ø 25/30 mm, 30 m long
- 2 lines, Ø 20 mm, 20 m long
- 1 line, Ø 25/30 mm, 50 m long
- 1 line, Ø 5 mm, 100 m long
- 1 spare anchor 30 kg
- 2 plastic buckets
- 2 synthetic sponges
- 2 empty 25 l cans
- 2 funnels of different size, complete with 50 cm rubber tube
- 15 kg of engine oil
- 10 kg of gear box oil
- 5 kg of hydraulic oil for the steering system
- 2 kg of hydraulic oil
- 5 kg of anti-freeze liquid
- 1 kg of oil for the bow thruster
- 10 kg of oil for the electro-hydraulic system
- 1 complete set of navigation lights
- 2 engine room lights
- Insulating tape
- Stainless steel pipe clamps of various size
- 1 underwater light
- 2 pairs of heavy duty rubber gloves
- 3 kg of white rags
- 1 CRC spray can
- 1 Vaseline spray can
- 1 engine spare parts kit
- 1 generator spare parts kit
- 1 watermaker spare parts kit
- Battery for smoke detection system
- Signal light battery
- Noise-proof earphones

3.10 SCHEDULE

Minimum rescue facilities and safety equipment to be kept on board of yachts and pleasure yachts with no limit of distance from the shore and with expiry date.

	2027	2028	2029	2030	2031	2032	2033	2034	2035
Self-inflatable life raft (for all persons on board)									
Individual life buoy (for each person on board)									
Life jacket with rope (floating type)									
Light buoy									
Smoke buoy									
Red light hand fires									
Red signal rockets with parachute									
Compass and deviation schedules									
Nautical charts									
First aid kit									
RTF inspection									
Property tax									
Insurance									
License (pilot)									
Portable fire extinguishers									
Fixed fire extinguisher in the engine room									
E.P.I.R.B.									

Riva

102 CORSAIRO *supera*

DESCRIPTION OF THE YACHT

CHAPTER 4

4.1 MAIN DIMENSIONS AND CHARACTERISTIC DATA OF THE YACHT



(Loa) Overall length	30,24 m	99 ft 3 in
(Lh) Hull length	23,97 m	78 ft 8 in
(Lg) Waterline length (boat fully laden)	22,30 m	73 ft 2 in
Maximum beam	6,70 m	22 ft 0 in
H max = Overall height from keel	9,82 m	32 ft 3 in
Pulpit + stern	6,27 m	20 ft 7 in
Depth under propellers (boat fully laden)	2,3 m	7 ft 7 in
Displacement unladen	99000 kg	218258 lbs
Displacement laden	110000 kg	242508 lbs

Features		
Hull type		Variable geometry with 12° deadrise and supporting skids
Construction material		VTR
Propulsion	Model	MTU 2000 M96L
	Configuration	16 cylinders a V
	Power	1939 kW (2638 mhp)
	rpm	2450 rpm
	Dry weight	3450 kg (7606 lb)
	Displacement	35,70 lt (2179 cu in)
Propellers	Type	Shaft line
Fuel tank capacity	lt (Gal) approximately	9000 (2378)
Water tank capacity	lt (Gal) approximately	1320 (349)
On board electric power supply	(V)	120/240 single-phase by power generators
	(V)	24 by batteries
Power generator (no. 2)	Model	2 x Kohler 32 EKOZD
	Voltage (V)	120/240 single-phase
	Frequency (Hz)	60
	Power (kW)	32+32
Batteries	Engine (No.)	4
	Services (No.)	12
	Generator (No.)	2
Bilge pumps	Engine room (No.)	3
	Port-side VIP cabin (No.)	1
	Starboard VIP cabin (No.)	2
	Bow crew area (No.)	1

**CAUTION**

RIVA yachts are designed to obtain a correct transversal trim with full optional equipment, as well as propellers and shafts.

If the yacht is not provided with full optional, some weights are inserted to correct the transversal trim.

The above-mentioned weights can be removed or displaced as soon as the yacht is provided with a new equipment.

NOTE

The technical specifications and the performances indicated are merely indicative, and do not constitute an offer with the value of a contract in any way, and are referred to standard models of the yachts built by the Shipyard in the European version.

The only technical indications or descriptions with contract value for the purchaser are those relevant to the specific yacht purchased and contained in the sale documents.

**WARNING**

When loading the yacht, never exceed the maximum recommended load. Always load the yacht carefully and distribute loads appropriately to maintain design trim.

4.2 GENERAL ARRANGEMENTS

This chapter contains a general description of the yacht and is supported by a set of illustrations thanks to which it is possible to easily locate the main areas and the different devices.

Advice and information on the correct use of the various instruments are also given.

The structure of the yacht has been divided as follows:

- Main Deck - Exterior
- Main Deck - Interior
- Upper deck
- Lower Deck
- Fly Bridge
- Aerials
- Engine room

The yacht is provided with both electronic and mechanical devices and instruments; some of these are provided with their own user's manuals.

NOTE

For further information on use and maintenance, please refer to the manufacturer's manual.

4.2.1 Keys of the yacht

With the yacht all the keys are delivered, they have different handles and each one of them is supplied in two or three copies.

The keys can be recognized by a code number printed on them. Rewrite the code into a list if you need another copy.

The keys are:

- Engine keys:
 - 2 copies to start the starboard engine;
 - 2 copies to start the port engine.
- Keys for salon entry (salon door): 3 copies.
- Keys for cabs access: 3 copies.
- Keys for crew area and engine room access: 3 copies.

The other locks of the yacht are universal; the same key opens all locks.



CAUTION

For the safety of the persons on board, the Captain should have an identifiable copy of the keys on board for any occasion.

Always keep a copy of the keys on your yacht and always contact RIVA in case of deteriorated or altered locks.

In addition to the different keys, the yacht is equipped with a remote control allowing to control the gangway remotely.

On the starboard side of the aft transom there is a receiving photocell, which detects the signal sent by the remote control and forwards it to the hydraulic control unit. The radio control must be directed towards the photocell and no obstacles must stay in their way.





CAUTION

The hydraulic gangway, even if easy manoeuvrable, might damage people and things. Its use is recommended only to well experienced people.

4.3 MAIN DECK - EXTERIOR

1. Preparation for installation of swim ladder
2. Garage hatch/ sofa in swim area
3. Port mooring cabinet
4. Stern cockpit
5. Fuel inlet and fresh water inlet nozzles
6. Port walk-around
7. Bow access staircase
8. Starboard walk-around
9. Fuel inlet and black water discharge nozzles
10. Fly Bridge access staircase
11. Starboard mooring cabinet
12. Gangway extension
13. Shore electric power supply
14. Stern platform

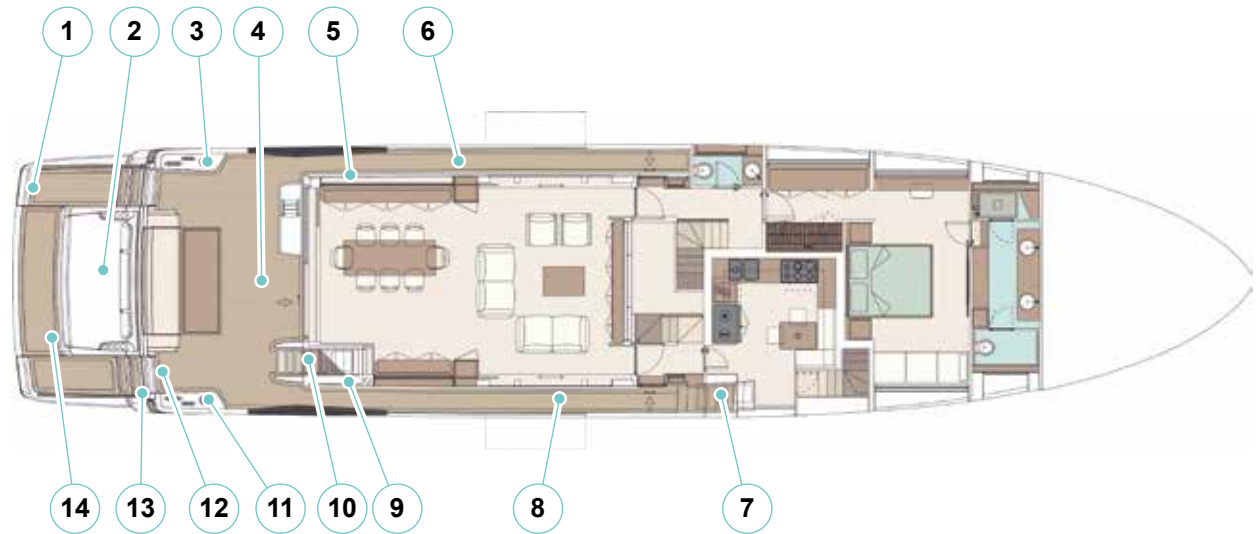

The access to the yacht from shore is enabled by a gangway located on the starboard side and stowed under the steps.

**CAUTION**

Always use the gangway to board the yacht; any other access system is potentially dangerous.

From the water, on the other hand, it is possible back on board via the swim ladder installed on the port-side of the stern platform from which the main deck can be reached via the two side stairs.

The swim ladder is stowed in the garage on the left side.

On the aft transom is the garage hatch, the garage can stow inside a jet-ski.

The garage hatch can be activated through a remote control located in the stern platform access ladder.

**DANGER**

Never stay on the stern platform during navigation, because this is not equipped with protection rails preventing a possible fall at sea.

**DANGER**

Never start navigation with the gate, stern platform, gangway or garage hatch not properly stowed/closed.

**DANGER**

The garage hatch must always be closed during navigation, it can stay open only with yacht stationary and with favourable sea weather conditions. Loads stowed inside the garage, in particular the tender and jet-ski, must be fastened with the utmost care. During navigation nobody should stay inside the garage.

**DANGER**

As the opening/closing of the garage hatch is performed by an electronic mechanisms, always check that no obstacles or persons are standing nearby before its activation, this operation has to be performed exclusively by skilled crew.

**CAUTION**

Periodically check that groundings are in order. Keep connections dry and protected with anti-corrosion grease.

**CAUTION**

In case a jet-ski is used, each passenger must wear a life jacket; the driver must also have a regular license and keep to the rules of the country where the jet-ski is driven.

**DANGER**

Stop using the on-board handlings if the sea-weather conditions (wind, currents, weather factors) could jeopardize the yacht's stability.

On the main deck there is a comfortable bench equipped with a practical table. On both sides of the yacht inside the mooring lockers the aft cleats and the warping winches are stowed, useful for shore approaching manoeuvres.

**CAUTION**

Do not use the warping winches as permanent mooring points.

On the port side of the cockpit, there is a cabinet hiding the entrance to the engine room and containing the third helm station.

Both walk-arounds, protected by external handrail, allow the access to the bow area.

**WARNING**

When leaning on the outside handrail, be careful so as to prevent any accidental fall at sea.

Along the starboard walk-around leads to the bow area, while the port walk-around leads to the inner rooms.

The anchoring unit is on the bow of the yacht.
The anchor winches are centrally positioned.

The four side cleats are also positioned at the bow.

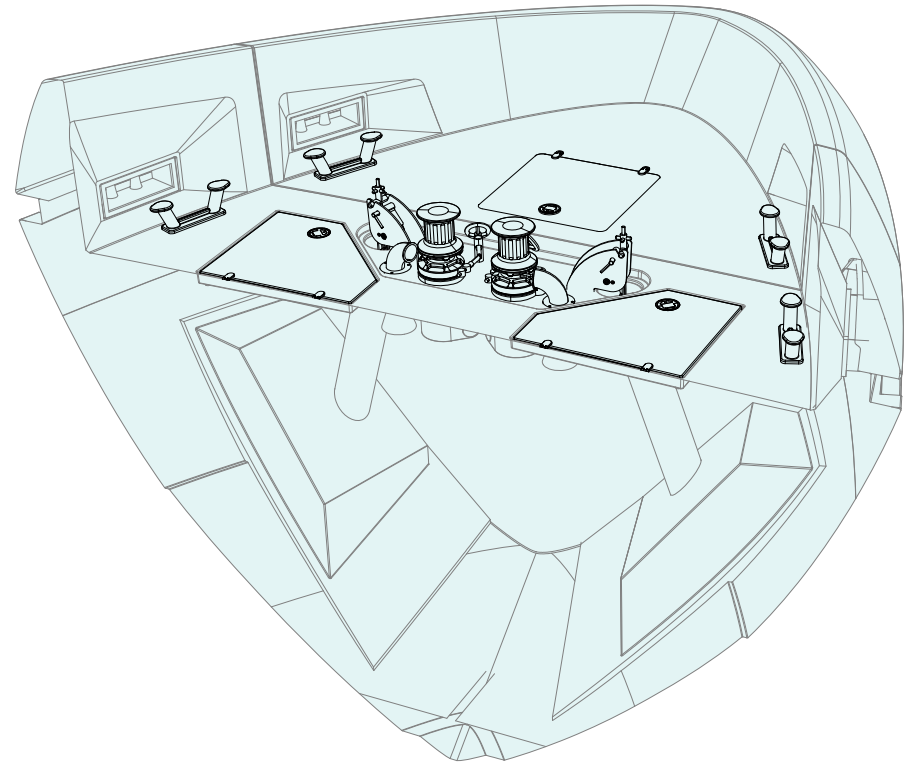

Inside the bow peak there are also the remote control for the anchor winch, the hose connection for deck washdown, the solenoid valve controlling the anchor and chain washdown and a fresh water tap.



CAUTION

The protection railing is interrupted at bow for the anchor weighing.



DANGER

Pay particular attention to rotary pieces, keeping your feet, hands, clothing and hairs at due distance.

If you control the anchor winch from the main helm station make sure that nobody is near it and that your visual field is free.

4.4 MAIN DECK - INTERIOR

- 1. Sliding door (optional)
- 2. Dining room
- 3. Lower deck access stairs
- 4. Service bathroom
- 5. Owner's cabin
- 6. Owner's cabin bathroom
- 7. Crew area access stairs
- 8. Galley
- 9. Access stairs to the helm station
- 10. TV cabinet with electric lift
- 11. Lounge with sofa and coffee table

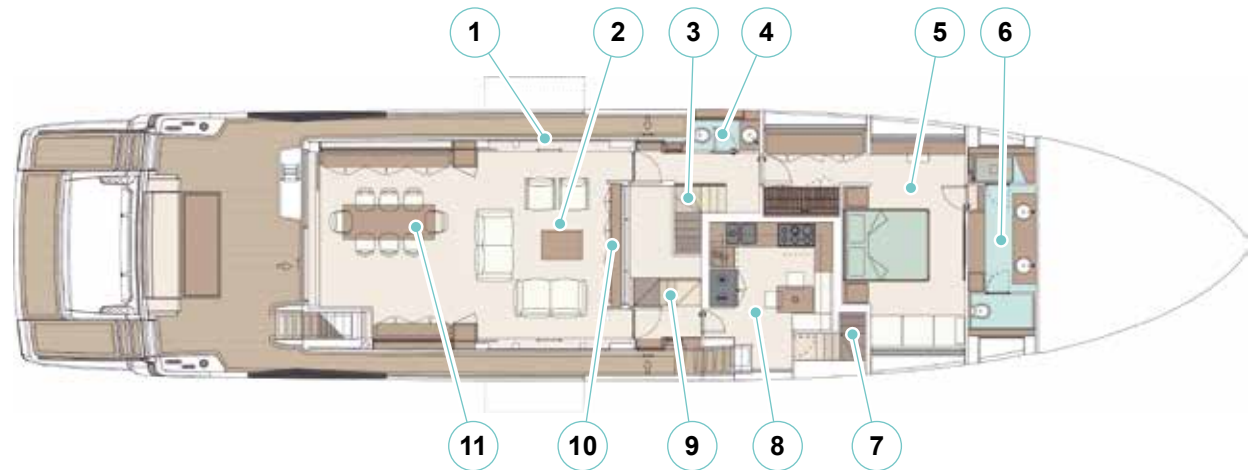

A wide salon door allows the access to the salon of the yacht. The salon door consists of a stainless steel frame and shading glass panes, which protect against sunlight reflections while allowing a view outside. Venetian blinds are also mounted on the windows. They are space-saving, with rod orientation, rope lifting and lateral flush guides. The salon door is adjustable; the adjustment is performed at sea after the navigation tests carried out by RIVA; any modification performed by unauthorized personnel is strictly forbidden.

**CAUTION**

For the adjustment of the salon door, refer to the RIVA After Sales & Service Department.

**CAUTION**

Never start navigation with salon door unlocked. Its structure, if free, might develop an inertial force causing dangers of cuts or crushing.

In the centre of the lounge there is a dining table.

**CAUTION**

The living room is equipped with an air conditioning system, as most of the yacht's rooms; therefore, we recommend opening the glass-wall as little as possible when the system is operating.

At the centre of the yacht is the lounge furnished with a comfortable sofa. At the bow of the saloon in the centre of the yacht is an elegant piece of furniture containing the HI-FI system and the television with its electric riser. The various compartments of the cabinet all open via push-button opening.

**CAUTION**

It is not recommended to move during navigation, because a lateral skid of the yacht could have a negative effect on a moving passenger, causing an accidental fall or the impact against a piece of furniture.

**CAUTION**

Do not leave anything on the door of the TV cabinet. Make sure that nothing can fall into the TV cabinet.

Moving towards the bow on the starboard side leads to the galley.

The galley is practical and gathers all the essential household appliances. During navigation it is advisable to properly close all doors. The dishwasher takes water from the cold fresh water system. It is connected with the sink draining and discharges at sea. In the galley, above the electric burners there is a suction hood to eliminate the cooking smokes.

**CAUTION**

Always check the absorption of the household appliances and deactivate them in case they are not used.

**CAUTION**

It is recommended not to fill pots more than 50% with water and not to use pressure cookers.

**CAUTION**

In order to eliminate smells, vapour or fumes, it is necessary to turn on the suction hood at cooking start and to keep it on at cooking end for 10-15 minutes.

**CAUTION**

When using the galley, increase the ventilation of the inner rooms as much as possible. Never use the cooking top to heat the room.

**CAUTION**

For the procedures and the correct use of the various household devices of the galley, refer to relevant manuals.

The electric cooking top includes 4 burners and some pan stoppers can be installed on the port side.

**CAUTION**

Do not leave pans unattended when they are on the burner.

**CAUTION**

Children are allowed to use the galley only when they are able to use its items correctly and to understand the dangers specified in the special instruction manuals. The help of an adult is required.

The microwave oven is located under the cooking top.

**CAUTION**

Do not put liquid food into the oven.

**CAUTION**

Never place metal containers with metal inserts in the oven.

4.5 UPPER DECK

1. External sundeck area
2. Helm station

NOTE

For more information on the external sundeck, see the descriptions for the Fly Bridge.



CAUTION

The main helm station is located on the Fly Bridge, as from the station on the upper deck the visibility is reduced. A special plate affixed by the manufacturer it draws attention.



CAUTION

The removable curtains and the relative support poles must always be dismantled and stored in the appropriate seats before starting navigation. When not in use, the poles must be stored in special places. Curtains should only be installed when the yacht is stationary and with favourable weather and sea conditions. Do not leave curtains open in case of heavy rain. Do not leave the curtains installed in an unattended yacht. Do not let water pool on the fabric of the curtains. When not using the curtains, keep the pole engagement holes closed with the appropriate covers.

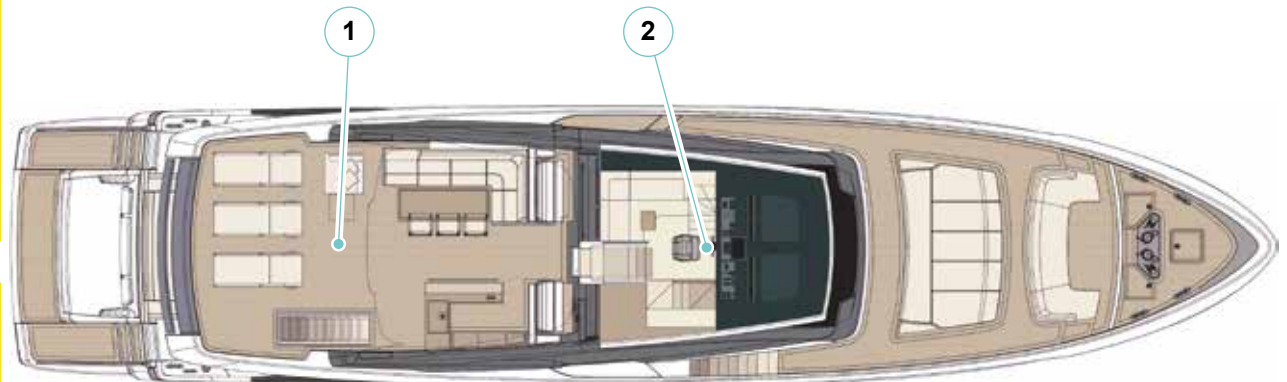

4.5.1 Helm station

The access to the helm from the inside is possible through the starboard staircase (aft than the galley), while, from the outside, it is possible from the bow staircase on the Fly Bridge.

The main helm station allows the use and view of all the yacht's steering instrumentation.



DANGER

The personnel operating the yacht during the various activities on board must not be under the influence of alcohol, narcotics or drugs.



CAUTION

For the correct use of the various devices installed in the main helm station, see the relevant instruction manuals.



CAUTION

It is not recommended to move during navigation, because a lateral skid of the yacht could have a negative effect on a moving passenger, causing an accidental fall or the impact against a piece of furniture.



WARNING

To prevent circumstances that could lead to property damage, injury or death due to the improper use of the helm and its controls, the yacht's owner/captain must ensure that inexperienced or unauthorized persons are never permitted to be at the helm station.



CAUTION

Turn on the spotlights of the passage ways so as to ensure a proper lighting. Check the operation of the spotlights and, if necessary, replace their bulbs.

NOTE

Normal yacht motion in a seaway can cause accidental movement of access doors and hatches. Personal injury can result if doors and hatches move suddenly. Before the navigation, close and secure all access, doors and hatches.



WARNING

During navigating, the yacht's normal movement in the water can cause the slipping or falling of persons with the potential hazard of serious injury or even death. Persons should remain seated in secure locations when the yacht is navigation.

4.6 LOWER DECK

- 1. Engine room
- 2. Port VIP bathroom
- 3. Port VIP cabin
- 4. Port Guest bathroom
- 5. Main deck access staircase
- 6. Port Guest cabin
- 7. Owner's cabin
- 8. Owner's bathroom
- 9. Port crew cabin
- 10. Starboard crew cabin
- 11. Crew lobby
- 12. Main deck access stair
- 13. Starboard guest cabin
- 14. Starboard guest bathroom
- 15. Starboard VIP cabin
- 16. Starboard VIP bathroom

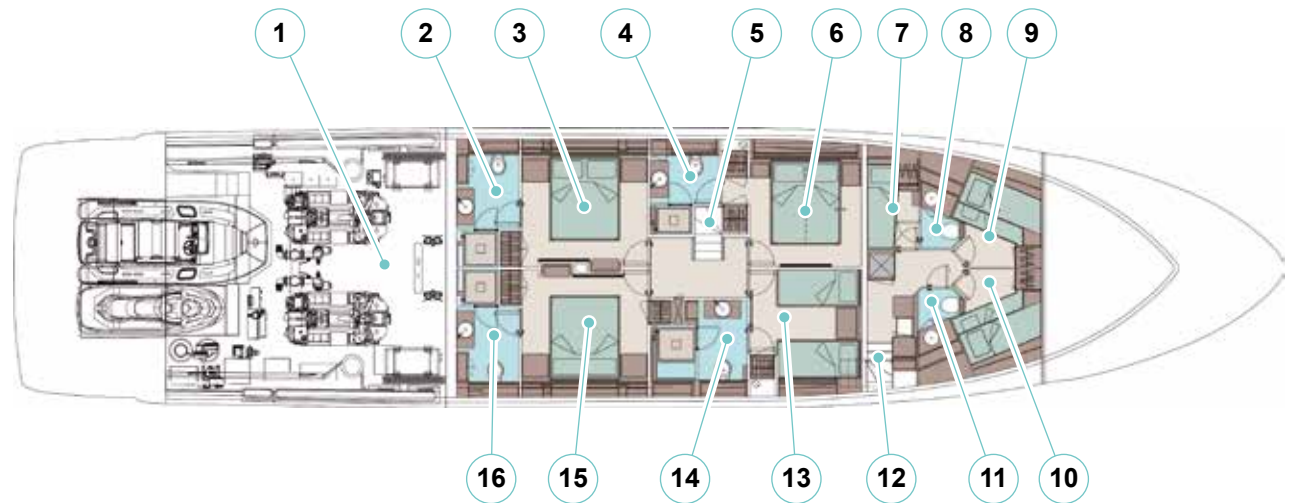

The lower deck consists of three areas, which are accessible from different not-connecting places. The areas are:

- Cabins with bathroom:
 - Owner;
 - VIP;
 - Guests.
- Engine room;
- Crew cabins with bathroom.

**CAUTION**

Before any navigation, check the closure of the cabs access doors. You will avoid unpleasant banging and accidental dangers.

4.6.1 Crew cabin and bathroom

It's possible to access the crew cabins through the staircase placed on the starboard side of the galley.

The bow cabins (port and starboard) have two beds arranged in a bunk structure and bathroom. Therefore on the port side is the captain cabin with a single bed.

The cabins are equipped with portholes, which allow ventilating them, while, on the port side, there is the crew bathroom.

**CAUTION**

Close the portholes during navigation or when the yacht is left unattended for a long period.

The cabin is equipped with a self-adjustable air conditioning. For adjustment refer to specific chapter "Air conditioning system".

A multifunction display in the crew area can be used to control the operation of on-board systems.

4.6.2 Cabins with bathroom: Guests and VIP

After descending the stairs, illuminated by spotlights, on the right are the access doors to the VIP cabins.

The VIP cabins are located opposite each other, to utilise the full width of the hull, and are furnished with a double bed and various storage cabinets. The VIP cabins provide access to the cabin bathroom with a large shower.

On the port-side (towards the bow), there is access to the port and starboard guest cabins.

The port-side guest cabin has a double bed and a separate bathroom.

On the starboard of the yacht is the guest cabin which is equipped with two single beds. It is equipped with a large wardrobe and a separate bathroom.



CAUTION

The extremely precious finishing of woods used for the bathrooms floors and for the cockpit tables is the result of an accurate work, water resistant but at the same time delicate and needing accurate maintenance. Such surfaces must therefore be dried after use, after being exposed to rain and or washed, and a regular maintenance must be carried out.

All cabins are equipped with self-adjusting air conditioning.

4.6.3 Porthole

The porthole consists in a fixed part (frame) and a moving part (window). For opening, it is necessary to unlock the window by turning the handles 90° outwards. Closing is done by means of a thick seal on the porthole frame. It is necessary to make sure that the two knobs are correctly closed, in order to make the window seal adhere well to the frame.



CAUTION

The mosquito net (optional) hinders the sealing of the portholes, take it off before closing the porthole.



CAUTION

Close the portholes and the skylight when navigating or when the yacht is left unattended for a long period.

4.7 FLY BRIDGE

1. Sofa
2. Yacht bow access door
3. Helm station
4. Pilot seat
5. Utility cabinet
6. Access from the cockpit
7. Sun-deck area



WARNING

When the fly helm station is not used, it is advisable to protect its instruments with relevant covers and a protection cloth.

MAINTENANCE

FLY BRIDGE LIGHTING SYSTEM

At least once a week carry out an accurate cleaning.
 At least once a month check the operation.
 At least once every three months check the presence of corrosion.



WARNING

The use of side locking systems, such as Cristal or similar, is not allowed during navigation.

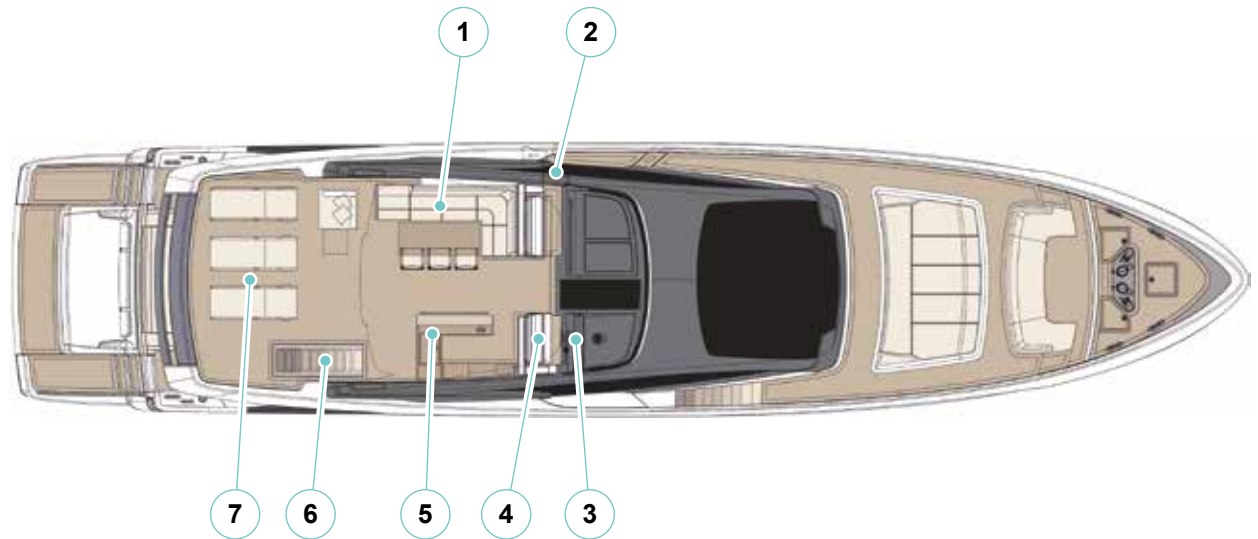

4.8 ANTENNAS, NAVIGATION LIGHTS AND DAYLIGHT SIGNALS

4.8.1 Antennas



CAUTION

During transmission, keep off more than 2 metres from the TV-SAT aerial.



CAUTION

Access the Hard Top only with safety belt by qualified/trained technical personnel for work at height.

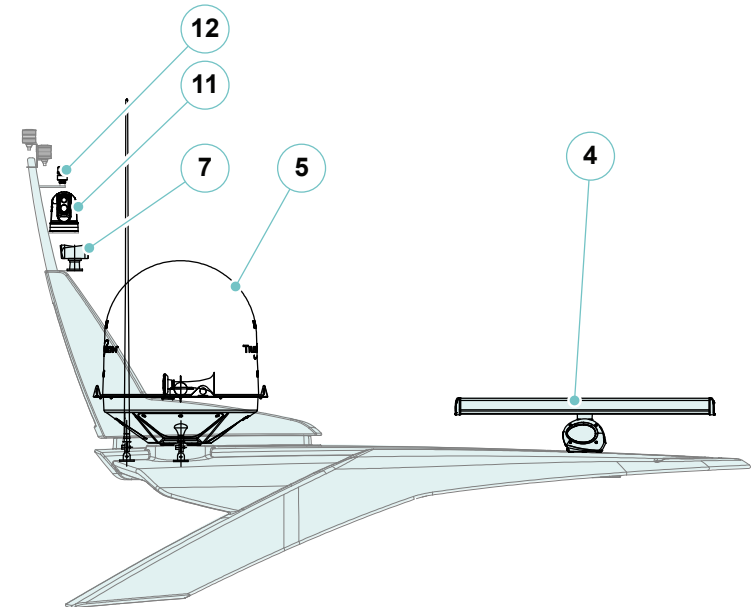
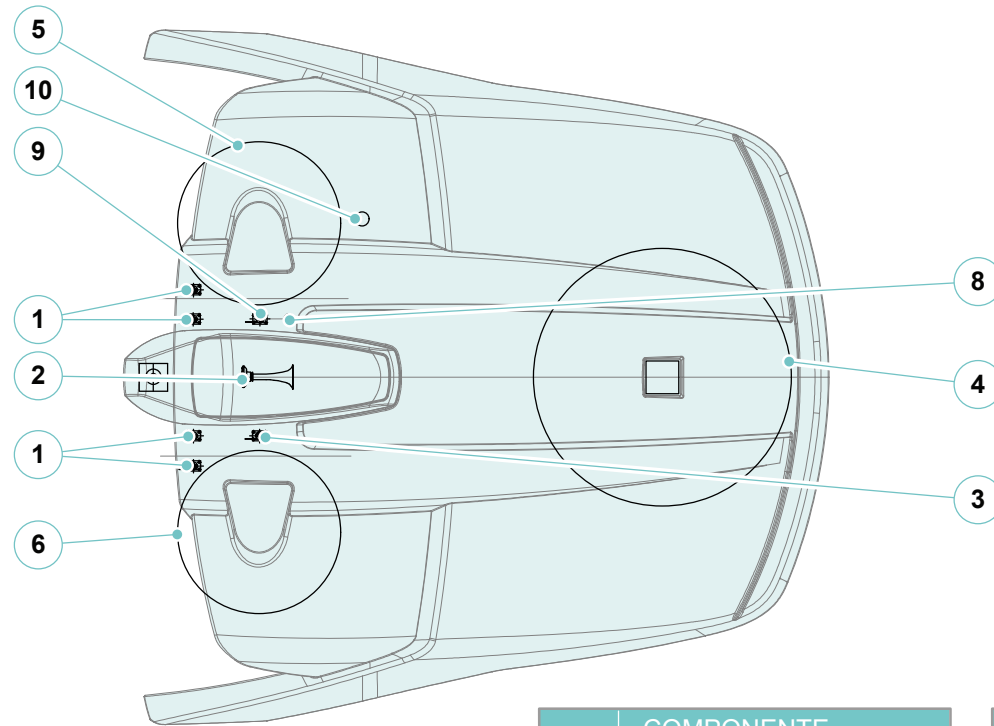

N°	COMPONENTE COMPONENT
1	Antenna VHF VHF antenna
2	Tromba Horn
3	Antenna GPS attiva GPS antenna
4	Antenna radar HALO HALO radar antenna
5	Antenna TV SAT TV SAT antenna
6	Antenna TV SAT KVH TV8 TV SAT KVH TV8 antenna

N°	COMPONENTE COMPONENT
7	Faro orientabile Searchlight
8	Antenna TV terrestre Terrestrial TV antenna
9	Antenna GPS GPS antenna
10	Antenna MTU MTU antenna
11	Termocamera Thermal camera
12	Stazione meteo Weather station

4.8.2 Navigation lights

The rules relevant to the navigation lights must be observed from sunset to dawn and during this period no other lights must be visible except the lights that cannot be exchanged for those specified in this manual.

Although the lighting system is preset by the Manufacturers, the Owner/Captain has the responsibility for the observance of the local rules.

Please note that the local and international rules relevant to lighting can slightly vary, we suggest therefore to gather information about the local rules of your area.

Night navigation requires more precaution. All rules are applicable but apart from the right of course, it is advisable to slow down and to keep the proper distance from other boats.

It is a good rule to remember that bright lights reduce visibility at night.

Mast head light (white)

Visibility range 225°.

Shown by every engine-driven yacht.

Side lights or navigation lights (red port, green starboard)

Visibility range 112° 30' each.

Shown by any moving yacht and caused by any reason.

Aft light (white)

Also called stern light, visibility range 135°.

Shown by any moving yacht and caused by any reason.

Anchor riding light (white)

Visibility range 360°, can be seen from any point of the horizon.

Seen from every anchored or under navigation yacht, or in specific circumstances.

MAINTENANCE

At least once a week check the operation of the navigation lights.

At least once a week carry out accurate cleaning of glasses and headlights.

At least once every six months check the presence of corrosion in the connections of the navigation light cables.

At least once every six months, tighten the cable connections of the navigation lights.

The use of headlights during the various situations of use of the yacht during night navigation are illustrated below:

- **Navigation:** Masthead lights, side lights and stern lights ON.
- **At anchor:** Anchor lights ON.
- **Drifting:** Two red lights ON (no steering mast installed).
- **Stranded:** Anchor light and two red lights ON (no steering mast installed).



WARNING

Navigation lights, shapes and sound signals.

Where navigation lights, shapes and sound signals are installed, they must be in conformity with COLREG 1972 (II International Regulations for Preventing Collisions at Sea) or CEVNI (European Code for Inland Waterways). Regulations depending on the case.

**CAUTION**

The positioning of the navigation lights is optimised by adapting the regulatory requirements to the geometry of the yacht, providing lights where they are most easily visible.

Non-steering lights (N.U.C. = Not Under command) and a bell are not included in the on-board equipment.

The fitting of lights and sound signals is subject to the approval of the Flag Administration where the yacht is registered.

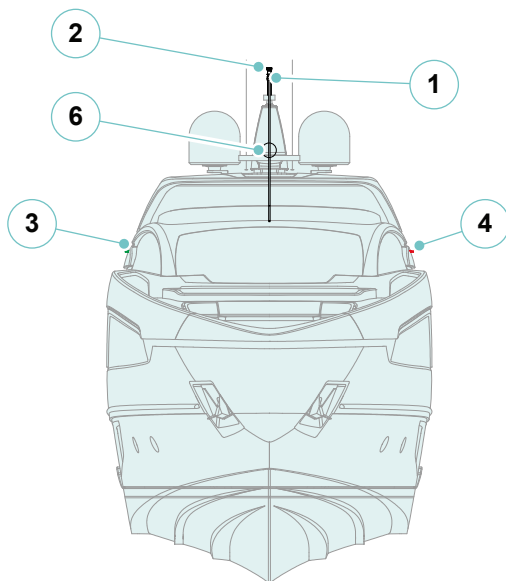
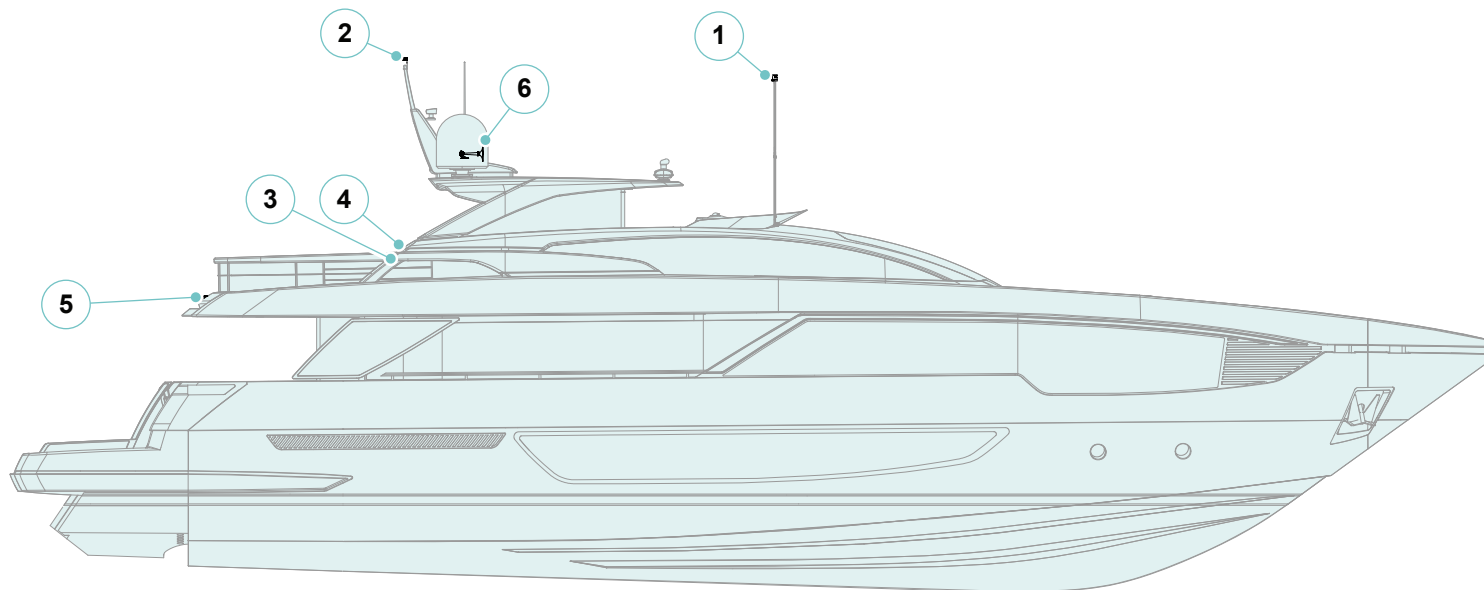

N°	COMPONENTE COMPONENT	COLORE / ANGOLO COLOR / ANGLE	VISIBILITÀ VISIBILITY
1	Fanale di testa d'albero 225° White mast head light 225°	Bianco / 225° White / 225°	5nm
2	Fanale di fonda 360° White anchor light 360°	Bianco / 360° White / 360°	2nm
3	Fanale di via destro verde 112.5° Starboard green navigation light 112.5°	Verde / 112,5° Green / 112,5°	2nm
4	Fanale di via sinistro rosso 112.5° Port red navigation light 112.5°	Rosso / 112,5° Red / 112,5°	2nm
5	Fanale di coronamento 135° White stern light 135°	Bianco / 135° White / 135°	2nm
6	Fischio pneumatico Pneumatic whistle		

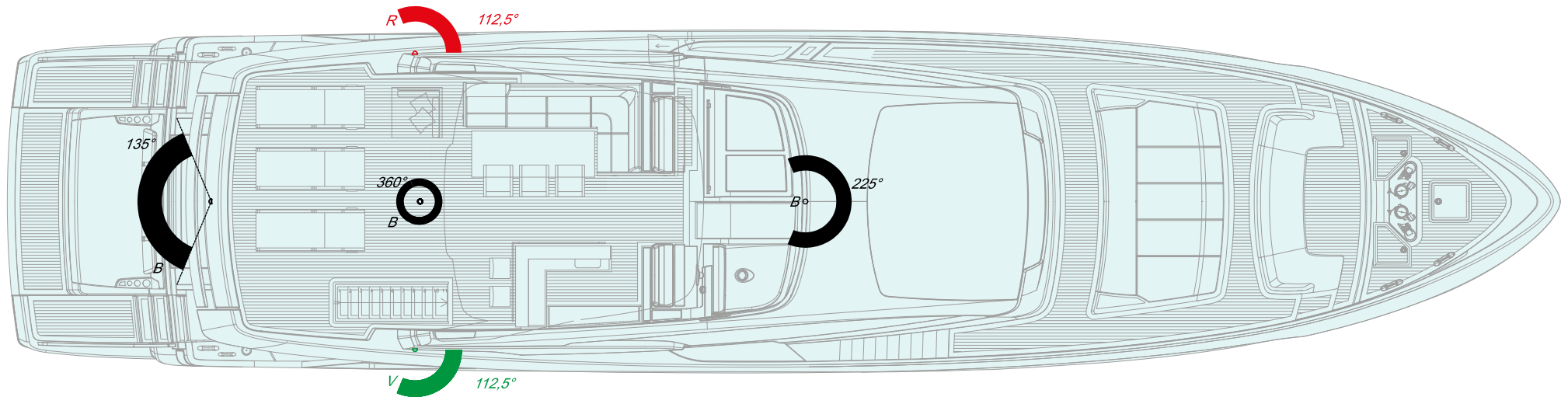

ICONA ICON	DESCRIZIONE DESCRIPTION
■	Rosso Red
■	Bianco White
■	Verde Green

4.8.3 Mast daylight signals

In order to increase the safety of people on board, the manufacturer has provided the installation of a mast for daytime shapes, in accordance with Directive 2013/53/EU.

NOTE

The combined use of shapes, sound signals and navigation lights increases the visibility of the yacht, reducing the risk of collisions.

Daytime signals have the same function as navigation lights but are more visible during the day than navigation lights.

Depending on the situation, appropriate signalling templates shall be used.

Hereunder is a list of the most common ones to adopt after installing the relevant mast:

- Yacht at anchor:



- Not under command yacht:



- Stranded yacht:

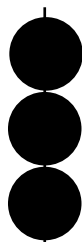

- Yacht with limited manoeuvrability:



- Yacht to trailer or towed:



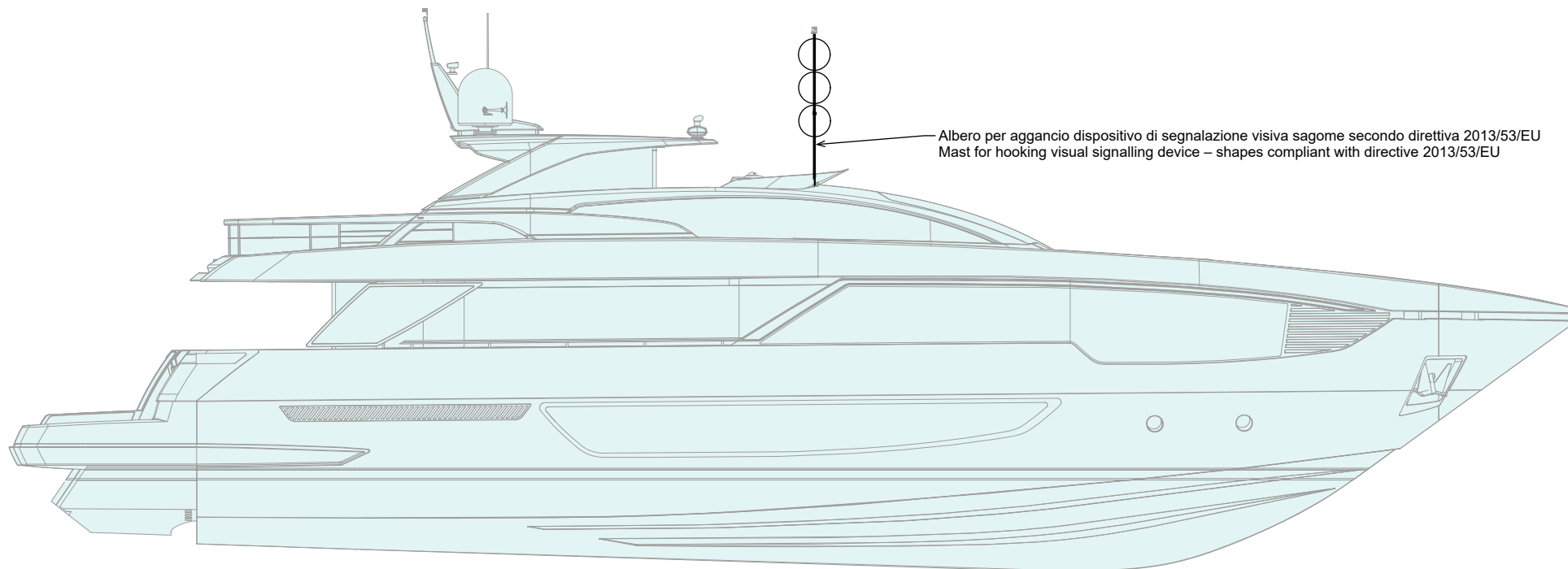

4.9 ENGINE ROOM

The engine room can be reached from two different places of the stern cockpit: through the central hatch on the floor, or through the access in the port cabinet.

Before entering this room, switch on the lights.

A multifunction display in the engine room can be used to control the operation of on-board systems.

**DANGER**

During navigation, access to the engine room is not allowed.

**DANGER**

In the engine room, thermal engines create highly radiated areas which keep temperature high for a long time. Protect yourself and wait until they are cool before entering the engine room.

**CAUTION**

Do not store free-to-move items in the engine room, as they might skid during navigation.

**CAUTION**

Only authorized personnel should have access to the engine room and also be informed about the components operation and about the features of the fire-fighting system.

**DANGER**

For safety reasons the watertight hatch, giving access to the engine room, must be kept closed by any time and situation. It must stay open only during the passage.

MAINTENANCE

At least once every three months tighten the discharge raiser bolts.

Riva

102 CORSAIRO *supera*

HELM STATIONS

CHAPTER 5

5.1 HELM STATIONS

Your yacht has three helm stations: the helm station console on Main Deck and steering wheel, the Fly Bridge console and the drive wheel. Different controls, instruments and navigation devices are installed at the two helm stations.

A third helm station is located in the stern cockpit.



CAUTION

Herewith only general information for first start-up is given: for the practice and the specific use of the individual systems, consult the manuals of the Manufacturers or the RIVA After Sales & Service Department.



CAUTION

It is a good rule to keep the instruments clean by washing them with wet and clean rags, avoid using chemical or abrasive products. After navigation, it is advisable to cover instrumentation and equipment.



CAUTION

All electric appliances for navigation, whose parameters can be configured and set by software through the control panel, have been configured and tested upon delivery. These operations must be performed exclusively by authorized Service personnel. Any modification of the preset configurations can alter the operation and reliability of the concerned system. Appliances must be used by the personnel in charge of driving the yacht and of using the systems.



CAUTION

HORIZONTAL FIELD OF VIEW - Stern Visual.
Yacht equipped with an autopilot. Manoeuvres that require visibility towards the stern are to be carried out by the helm station on the fly bridge, in accordance with the provisions of standard ISO11591.



CAUTION

The main helm station is placed on the Fly Bridge, since from the helm station positioned on the Upper Deck the visibility is reduced. A special plate affixed by the manufacturer draws the attention.



CAUTION

It is good practice to keep screens clean with damp rags but without using chemicals or abrasives.

Field of view diagram:

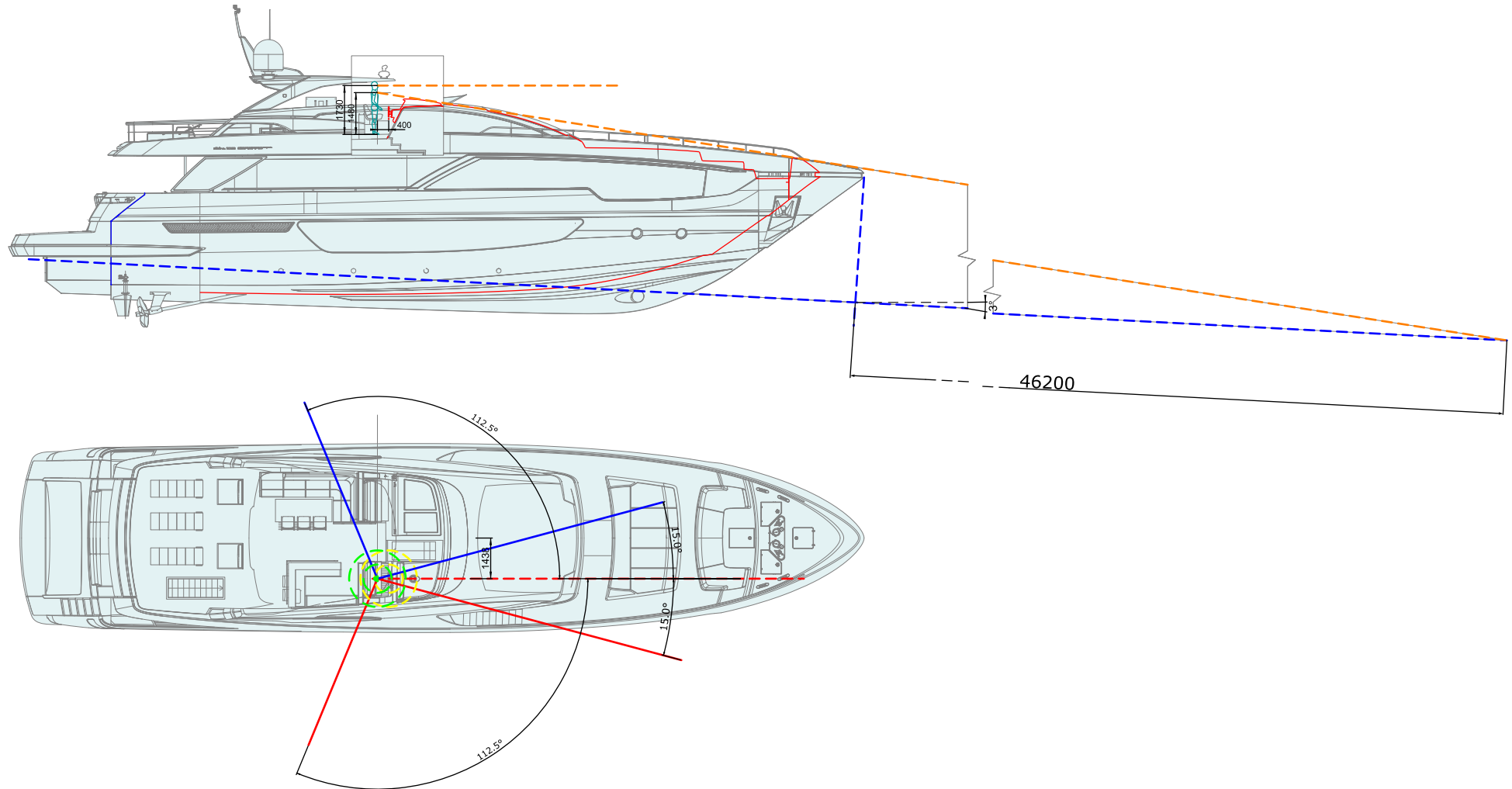

5.2 SUN DECK HELM STATION

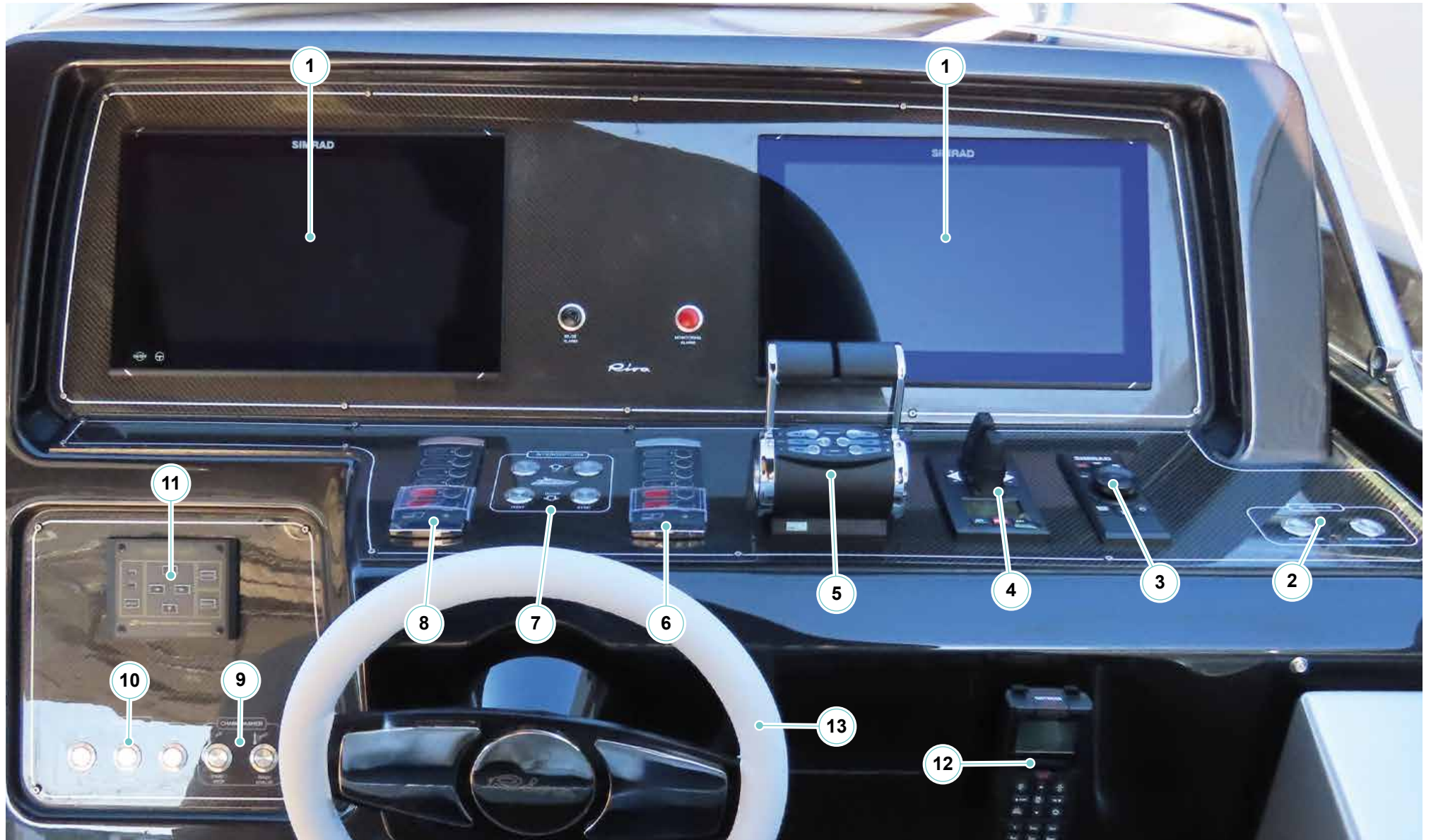

1. Multifunction monitor

Multifunctional navigation display of chartplotter, radar, fishfinder, monitor and video navigation data.

2. Helm station activation buttons**3. Multifunction display control keyboard****4. Thrusters control panel**

Pushbuttons and levers for controlling the thrusters levers.

**CAUTION**

When navigating with autopilot active, in the event of an obstacle in front of the yacht's bow, it is best to put the instrument in stand-by in order to definitively take command of the yacht. Once the obstacle has been passed, the instrument can be safely switched on again by setting the course once more.

5. Throttle

It controls, via electrical signals, the revolutions of the propulsion engines and the inverter gears.

6. Port-side engine controls

They allow the engine to be started and stopped, even in an emergency.

7. Interceptors control panel

They allow the handling and management of the starboard and port-side interceptors.

8. Starboard engine controls

They allow the engine to be started and stopped, even in an emergency.

9. Chain washer controls

Activate the starboard and/or port-side chain washer.

10. Various controls:

These buttons allow you to:

- Raise the pilot's seat;
- Lower the pilot's seat;
- Horn activation.

11. Searchlight control panel

Searchlight ignition and directioning pulses.

12. VHF-DSC radiotelephone

A Digital Selective Call (DSC) radiotelephone. The emergency and call buttons are protected from accidental use. Individual or group calls can be conveniently made from the keypad using either the internal directory or by inputting the number directly.

13. Steering wheel

5.3 UPPER DECK HELM STATION

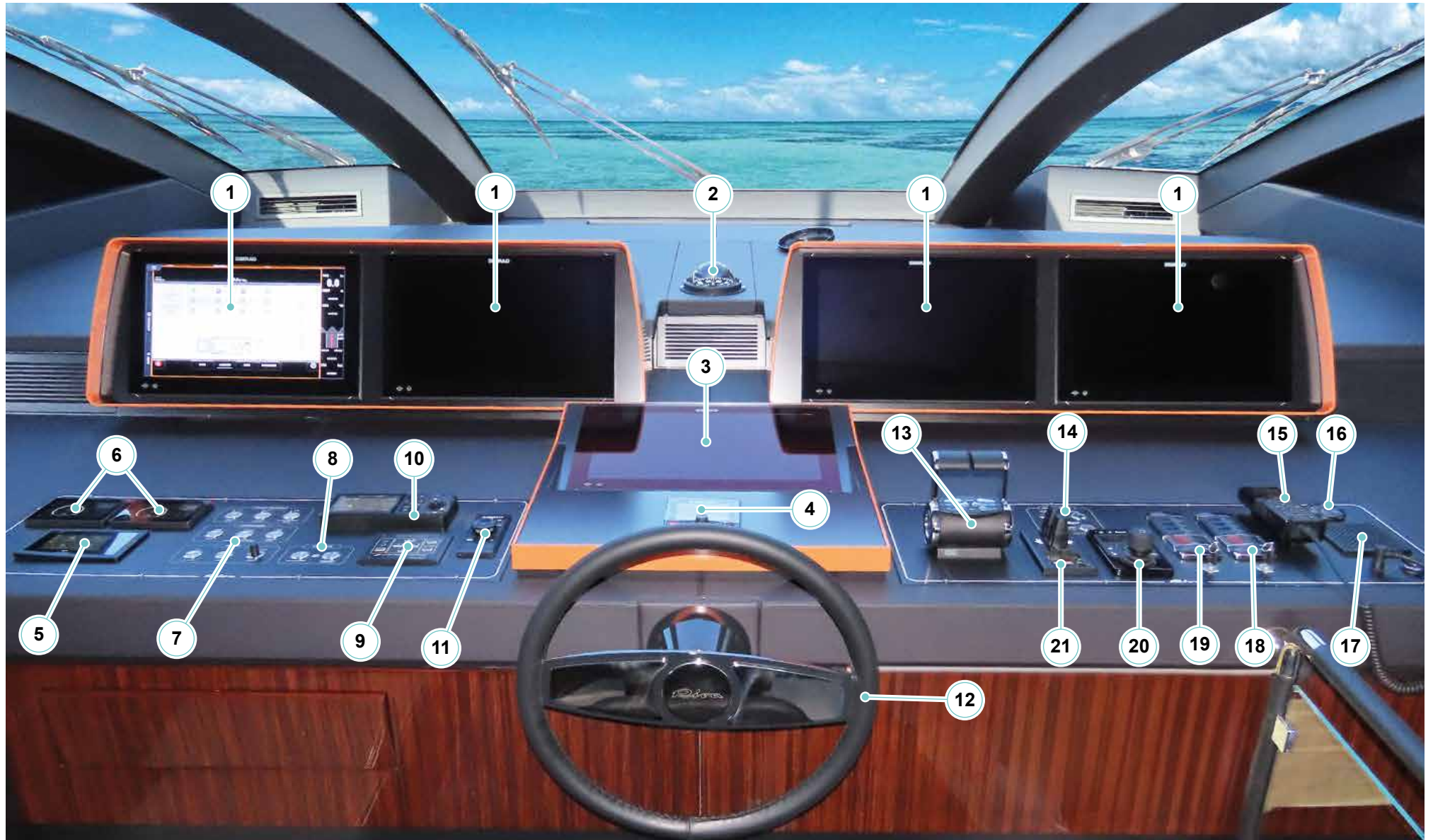

1. Multifunction display

It allows you to navigate through the setting menus of the yacht's control system and thus to view or set certain parameters.

2. Magnetic compass**3. Touch-screen monitor**

It allows you to navigate through the setting menus of the yacht's control system and thus to view or set certain parameters.

4. Display and autopilot tools

Allows you to monitor and set the autopilot.

**CAUTION**

When navigating with autopilot active, in the event of an obstacle in front of the yacht's bow, it is best to put the instrument in stand-by in order to definitively take command of the yacht. Once the obstacle has been passed, the instrument can be safely switched on again by setting the course once more.

5. Stabiliser fins control display

It allows you to monitor the operation of the stabiliser fins.

6. Gyroscopic stabilizer control panel

They allow to control the operation of the gyroscopic stabilizer.

7. Various controls:

These buttons allow you to activate:

- The starboard and/or port-side chain washer;
- The horn;
- Compass and anchoring area lights;
- The parallel connection of the batteries;
- The windscreen wipers, the speed and the relative windscreen washer pump.

8. Helm station activation buttons**9. Searchlight control panel**

Searchlight ignition and directioning pulses.

10. AIS system control panel

It allows to control the AIS system.

11. Multi-function display control keypad

Allows you to set the display of the multifunction display.

12. Steering wheel

It allows you to manoeuvre the yacht.

13. Throttle

It controls, via electrical signals, the revolutions of the propulsion engines and the inverter gears.

14. Interceptors commands

They allow the handling and management of the starboard and port-side interceptors.

15. VHF-DSC radiotelephone

A Digital Selective Call (DSC) radiotelephone. The emergency and call buttons are protected from accidental use. Individual or group calls can be conveniently made from the keypad using either the internal directory or by inputting the number directly.

This device is equipped with the Automatic Identification System (AIS) which allows to identify and locate other boats by electronically exchanging data with them.

16. Firefighting system control panel

The panel allows you to:

- Turn off the horn that signals that the system is running and the extinguisher is discharging gas.
- Change the light intensity of the CHARGE/ OVERRIDE panel lights.
- Exclude the control unit that in case of discharge of the extinguishing agent stops engines, generators and electric extractors. In the OVER-RIDE position this control unit is excluded.

17. Double USB socket**18. Management buttons and starter ignition key****19. Management buttons and port-side engine ignition key**

They allow the engine to be started and stopped, even in an emergency.

20. Thermal-camera control panel

It allows you to control the thermal-camera operation.

21. Thrusters control panel

Pushbuttons and levers for controlling the thrusters levers.

5.4 THIRD COCKPIT HELM STATION

- 1. Starboard engine management button**
- 2. Port engine management button**
It allows switching ON and OFF of the engine also, even in emergency mode.
- 3. Multifunction display**
It is a multifunctional navigation instrument with chart-plotter, radar, echo-sounder, navigation data, engine, video.
- 4. Thrusters control panel**
Buttons and levers to control the manoeuvring thrusters.
- 5. Throttle**
This block controls, by means of electric signals, the revolutions of the propulsion engines and the speed of the gearbox.

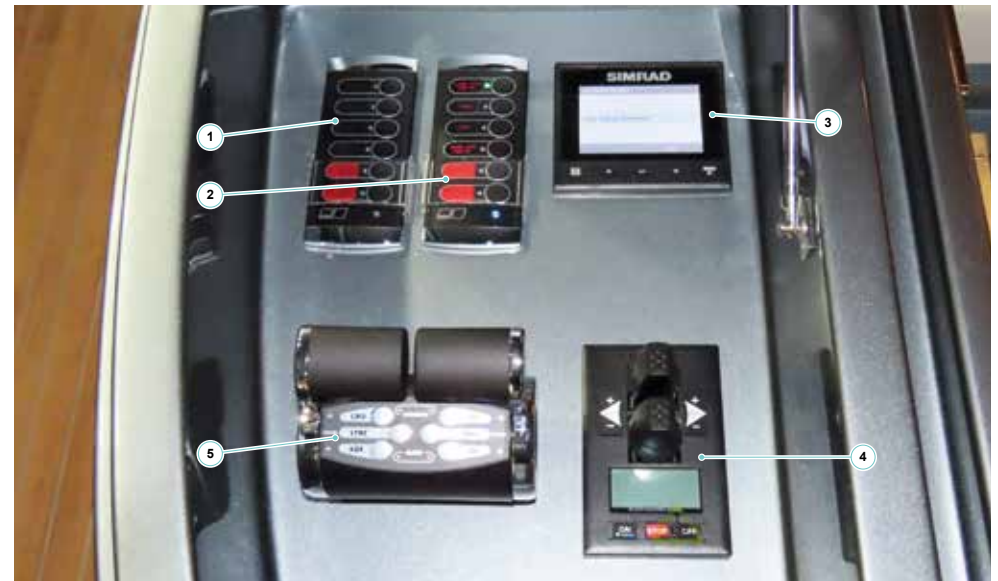

5.5 INSTRUMENTATION

5.5.1 VHF-DSC Radiotelephone



Operate the radiotelephone according to following instructions:

- Supply the radiotelephone with the magneto-thermal switch located on the main electrical panel.
- Turn the power on control; as default setting the device switches on the priority channel (16) frequency.

The display shows the channel number, the volume, and squelch levels.



WARNING

For channel selection or special function instructions, please refer to the radiotelephone Manufacturer's manual.

The keyboard has digital keys for the selection of the channels and function keys for the adjustment of the volume, of the squelch and of the scanning function.

The MENU key allows the access to the secondary functions. The PTT key (press for transmission) located on the port side of the device, is activated when the receiver is unhooked from the holder.

Key CH16 allows selecting the channel for vocal rescue request. It is however possible to carry out selective digital calls, quicker and simpler than the traditional calls. To obtain this, lift the protection flap placed on the front side of the radiotelephone.

Then press the DISTRESS key to get access to the various functions. Use keys ▲ and ▼ to scroll the various distress grades available:

- Not defined (default setting)
- Abandonment
- Piracy
- Man overboard (MOB)
- Fire
- Flooding
- Collision
- Grounding
- Listing
- Sinking
- Adrift

Keep **DISTRESS** key pressed to start countdown (4 seconds) before the message is sent.

Press **ON/C** to return to normal operation mode.

**CAUTION**

The DSC-call should only be made if the yacht is in a real distress situation. Otherwise, to send a DSC-call with no need is considered as an infringement.

NOTE

For further information on use and maintenance, please refer to the manufacturer's manual.

5.5.2 Throttle

The throttle is a system designed to control the revolutions of the engines and the speed to the gearbox by means of an electric signal.

The throttle have following performance features and functions.

- Sequence setting of gear box with engine speed.
- Start interlocking.
- Low/high idle run.
- Synchronization of engines for several propellers.
- Trolling solenoids control.
- Emergency control against back run.
- Gear box oil pressure interlocking (optional).

These features and operations facilitate the use of the throttles.

- Helm station indicator.
- Six two-coloured LEDs indicating the status and operation mode of control system.
- Acoustic transducer for indication of system status.

Taking control phases

- Set levers of throttle to idle position. The station cannot take control with throttles set to other positions. You hear the acoustic sequence of initialization.
- Press **COMMAND/SETTING (CMD)** at the station. The **COMMAND LEDs** turn on steady green to indicate that the station has taken over the command and the operator is sending the neutral command. The buzzer beeps at all stations.



WARNING

The next shifting of the throttles will engage the speed.

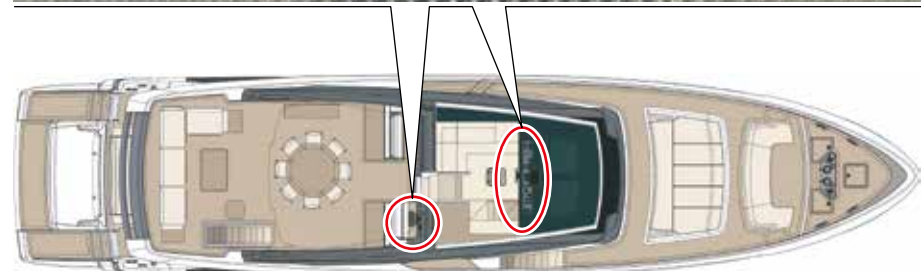

- Start the engine while sending the idle run control. If the levers of the throttle are not set to idle run, the interlocking start switch will prevent engine start.
- Move the levers to the forward or backward stop. The transmission system runs and the **COMMAND LEDs (CMD)** turn solid red to indicate that the station is in control and that the operator is sending the forward or reverse command.

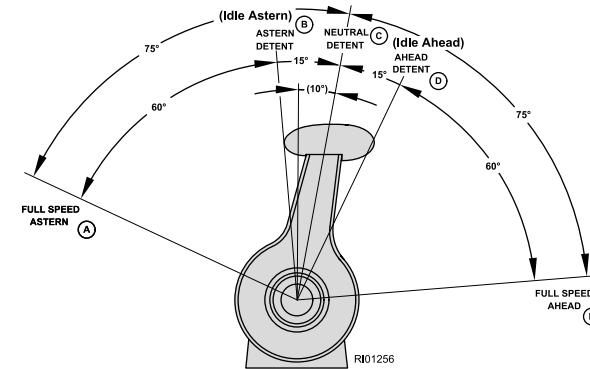

 **CAUTION**
Only one helm station can be active at a time.

Basic operation

The throttle has three detents: astern, idle and ahead. With levers positioned on idle detent, the system sends idle run and minimum rpm control to the engines. By shifting one lever forwards or backwards by 15°, the forward or reverse clutch engages. The engine holds the minimum rpm. By shifting same lever further, the engine's rpm increase proportionally to the shifting range.

Throttle detents

Indicator	Lever position
A	Full speed astern
B	Astern detent (idle astern)
C	Neutral detent
D	Ahead detent (idle ahead)
E	Full speed ahead

 **CAUTION**
The idle detent (central position in relation to handles shifting) is 10° ahead. The shifting degrees are measured according to this position, not to vertical position of the throttle.

NOTE
For further information on use and maintenance, please refer to the manufacturer's manual.

5.5.3 Engine control panel

The touch screen panel allows the visualization of the engine's data and to monitor it.

The monitoring system activates/deactivates automatically at engines electronics switching ON/OFF.

The engine and gear box data visualization is performed graphically on a screen with digital display of the values obtained. The screen can display the page with the list of faults.

Each fault detected by the monitoring system is preceded from symbols indicating the history of the alarm.

NOTE

For further information on use and maintenance, please refer to the manufacturer's manual.

5.5.4 Control panel for the bow/stern thrusters

For the operation of the thrusters, the relevant battery breaker must be activated.

The control panel carries the ON and OFF buttons and the joysticks for the bow/stern thruster control (with the silk-screened side arrows).

NOTE

For further information on use and maintenance, please refer to the manufacturer's manual.

5.5.5 Digital chain counter

The graphic display visualizes the length of the chain lowered, the instrument state and other information. The keyboard is equipped with three buttons. The two bigger keys control the anchor weighing (▲, key UP) or lowering (▼, key DOWN). They are used to scroll inside the system menus or in order to modify the parameters value.

NOTE

For further information on use and maintenance, please refer to the manufacturer's manual.

MAINTENANCE

At least every three months check the operation and when necessary, carry out adjustment.

5.5.6 Steering wheel

The steering wheel is connected to the rudder bar by means of an hydraulic driven system (with cylinders) able to develop a greater force, making steering easier during navigation.

NOTE

For further information on use and maintenance, please refer to the manufacturer's manual.



CAUTION

The wheels of the rudder from the control rooms are not interlocked. Before starting the operation to make sure that the remote helm station is not used, there are people who can operate the steering wheel.

5.5.7 Radar / Chartplotter / Depth sounder

The radar/chartplotter interlocks radar, depth sounder, plotter, ais, autopilot.



DANGER

Radiation danger.

The radar antenna emits radiations, which can damage the human body, especially the eyes. When the radar is operating, never look straight at the transmission aerial from a distance shorter than 10 m.

During the radar operation it is necessary to keep out of the aerial transmission flow. Switch OFF the radar if not expressly necessary to navigation.



WARNING

Pay the utmost attention during navigation, because in proximity of the yacht a shadow cone is formed, which is not covered from the radar waves.



CAUTION

The electronic chart is an aid to navigation, designed to facilitate the use of authorized steering charts, not to replace them. Only official steering charts and notices to mariners contain all information needed for the safety of navigation and, as always, the Captain is responsible for their proper use.

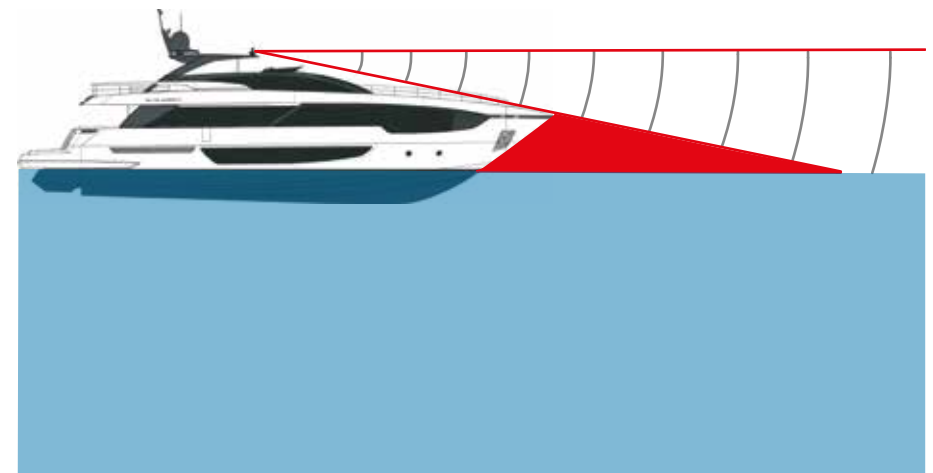

MAINTENANCE

At least once a week carry out the cleaning of the LCD.
At least once every six months check the connection and the presence of corrosion on the cables.

NOTE

For further information on use and maintenance, please refer to the manufacturer's manual.

5.5.8 Automatic pilot

The operation modes of the autopilot are following:

- AUTO (automatic control of the current heading as set course);
- NO DRIFT (advanced control of bow heading, cancelling the effects of wind, tides and rolling);
- NAV (track control);
- STBY (yacht control by means of the steering wheel).

The autopilot functions are checked by simply pressing the keys.

NOTE

For further information on use and maintenance, please refer to the manufacturer's manual.

**DANGER**

When navigating with the autopilot enabled and if there is an obstacle in front of the yacht's bow, the best thing to do is to switch the device to standby mode in order to definitively take control of the yacht. Once having bypassed the obstacle the device can be switched on by setting the track again.

**WARNING**

This instrument has been designed in order to offer the maximum precision and reliability; anyway its performance can be influenced by many factors. For this reason we recommend its use only as an help to navigation. A careful and continuous monitoring has always to be kept also under the best navigation and sea conditions.

MAINTENANCE

At least once a week check the correct operation.
At least once every six months check all connections.
When necessary have it calibrated.

**WARNING**

Never place electric and/or electronic sources of any kind closer than 1 meter from the autopilot compass (particularly in presence of loudspeakers, transceivers, tool boxes, etc..) because they could jeopardize the operation and reliability of the autopilot.

**WARNING**

An autopilot is a very useful navigational aid, but DOES NOT replace under any circumstances a human navigator.

Do not use automatic steering when you are:

- In heavy traffic areas or in narrow waters;
- In poor visibility or extreme sea conditions;
- When in areas where use of autopilot is prohibited by law.

When using an autopilot:

- Do not leave the helm unattended;
- Do not place any magnetic material or equipment near heading sensor used in the autopilot system;
- Verify at regular intervals course and position of yacht;
- Always switch to stand-by mode and reduce speed in due time to avoid hazardous situations.

5.5.9 Magnetic compass

A magnetic compass fitted on the dashboard of a yacht is inevitably close to the magnetic fields produced by the electric and electronic systems on board. This condition is called “variation”.

Only a skilled technician should set the compass to correct the variation and supply an accurate deviation schedule. This procedure is called “compass compensation” or “compass setting”.

Compensate the compass after the yacht launch or when replacing it, in order to eliminate possible mistakes due to the compass position.

Do not approach the compass to steel or iron objects or objects made of other ferrous materials (e.g. tools, wrenches, batteries, etc.). The ferrous materials close to the compass alter the readings and make them unreliable. Remove any unnecessary object near the compass.

NOTE

The compass delivered with the yacht is not compensated for change or deviation. Any electrical or metallic item located in its proximity may influence the compass. The yacht's owner is responsible for the compass compensation. Compensation should be carried out after installing additional electronic equipment or once a year after a prolonged period of mooring or ground lay-up. Compensation should be carried out only by authorized and qualified personnel. As a compass can rarely be set to zero variation on all courses, the technician in charge of its compensation should give you a card containing the corrections to be applied to navigation calculations. Always keep this card available on the main helm station.

NOTE

For further information on use and maintenance, please refer to the manufacturer's manual.



5.5.10 WATCHIT system (optional)

WATCHIT is an advanced system intended to assist the captain in operating the boat in a safer way by providing an alert about potential risks both over and under the water.

This system processes data from the on-board sensors (GPS position, heading, speed, rudder angle, LOG, wind indicator, etc..) and from the maps data which allows to constantly assess the risk of collision and issue warnings in real time to prevent accidents at sea.



CAUTION

Do not use the system as a navigational tool as it is not intended as such. This system is intended only as an aid to navigation and does not substitute safe and alert yacht navigation and operation by a qualified operator.

Once the system was installed on board your yacht and was calibrated, there is no need to actively operate the system. The only action needs to be taken before leaving your port or marine is making sure the power supply switch/fuse in ON and the system will automatically power up.

The system has 4 modes of operation:

- **Normal Mode** – In this mode the system will generate a vocal an obstacle alert in case it has detected a potential hazard on the yacht's path. The alert will be heard 30 seconds before impact in order to allow enough time for the skipper to react.
- **Crowd Mode** – Whenever the system detects multiple objects in the near surrounding and the yacht speed is less than 15 Knots - the system will automatically switch to Crowd Mode and the vocal alerts will be replaced with Beeps to inform the captain about any potential risks. The beeps frequency will increase as the risking object will get closer to the yacht.

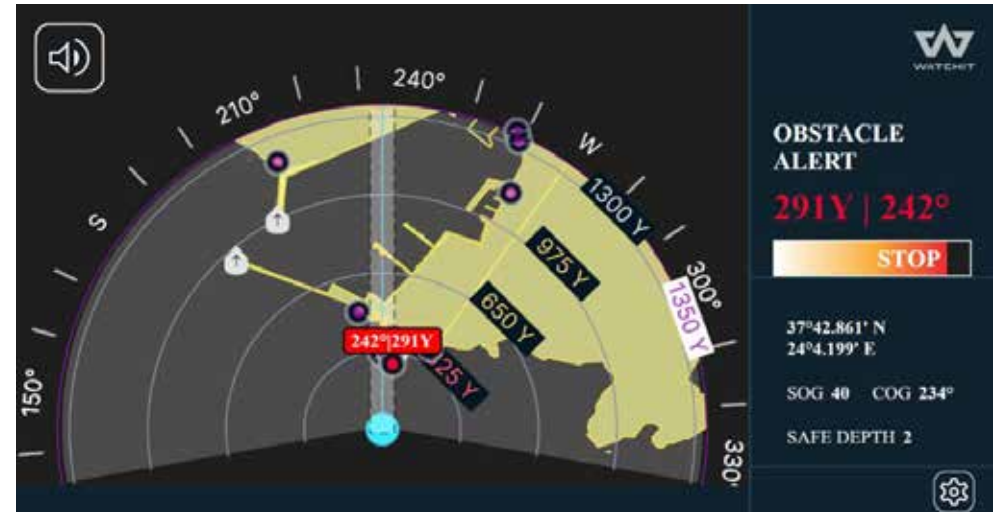

- **Anchor Mode** – Whenever the system has detected that the yacht has stopped – it will automatically switch to Anchor Mode. In case the system has detected the yacht is drifting, it will popup a Drifting Notification. After 5 minutes in case no one acknowledge the notification – a drifting alert will be triggered.
- **Marina Mode** – Whenever the yacht has entered a marina, the system will switch to Marina Mode. In this mode no vocal alerts will be heard.

NOTE

For further information on use and maintenance, please refer to the manufacturer's manual.

Riva

102 CORSARO *supera*

WATER SYSTEMS

CHAPTER 6

6.1 FRESH WATER SYSTEM

The fresh water system consists of 4 tanks of 330 liters each, for a total capacity of 1320 liters, located under the guest's cabin.

The following connections are installed:

- **Water inlet**
It is located on the deck on the left side walkway inside a locker.
- **Fresh water tank vent**
Located on the port side.
- **Fresh water suction**
It supplies water to the autoclave pump that keeps the entire fresh water circuit under pressure. On the pump line there is a filter that removes possible water impurities. The pump to operate must be supplied by the magneto-thermal switch located on the main electrical panel.
- **Tank water level transducer**
It checks the fresh water level in the tank. The water level in the tank may be monitored through the control panel.
- **Desalinated water inlet**
The tank can be filled not only from the water inlet, but also from the watermaker.

The yacht can be equipped with a water softener (optional).
The system can also be supplied from shore. The various equipment can be supplied without using the autoclave system in this way.

Your boat can be equipped with a UV sterilizer and an active carbon filter.

The fresh water system is equipped with an autoclave pump with electronic regulator.

- Less use of batteries since the pump is activated only with high flow requests;
- The pump continuous operation, eliminating the connection and disconnection phases;

- The device stopping the pump in case of water lack is installed on both pumps;
- The pump start after reaching the minimum pressure value set.

The panel with warning lights displays the various operation stages:

- Power ON (green light - voltage);
- ON (yellow light - pump runs for some seconds and brings the system under pressure).

At user connection the system starts the pump automatically, this latter stops when the user disconnects, after resetting the system under pressure.

When faults occur, such as water leak or pipe clogging, the electronic regulator indicates the faults by means of "Failure" red light and stops the pump. The system restarts either by pressing the red Restart button, or by handling on the magneto-thermal switch on main electrical panel (by cutting out/in the pump voltage supply).



CAUTION

Before refilling the fresh water tank, check that the water supplied by the shore fresh water system is drinkable.



CAUTION

The fresh water circuit, must be sanitized periodically by pouring in the case a specific disinfectant solution.

We recommend in any case that the water coming from the on-board system not be drunk.

**CAUTION**

On yacht equipped with direct connection to shore fresh water, the maximum operation pressure should not exceed 2.8 bar.
Notwithstanding the presence of a pressure limiter, check the pressure on the pressure gauge installed on board.
Disconnect the pipes for safety reasons, if yacht is left unattended.

**CAUTION**

Regularly inspect the fresh water and bilge circuits for leaks.
Repair any leaks by releasing the pressure in the system.

**CAUTION**

The pressure regulator at pumps output is set at the factory; do not modify.

**CAUTION**

The inlet plug is marked "WATER" to avoid accidental introduction of different liquids. To avoid damage to the system and tanks, we recommend replenishing by gravity and not by pressure.

**WARNING**

It is a good norm to optimise the use of water, especially if navigating at open sea!

**CAUTION**

In case of need, break or pollution of the tanks, they can be replaced.
Contact the RIVA After Sales & Service Department.

**CAUTION**

RIVA declines all liability for tampering made by third parties to equipment installed by the Shipyard itself.
These unauthorized manipulations, as well as in immediate cancellation of the warranty, can cause damage to the yacht itself and the people who are on board.
RIVA declines all liability for periodic maintenance activities not executed but planned by the Shipyard or by the Manufacturer of the devices or components, for which reference should be made to the consultation of the Technician Manuals.

MAINTENANCE

Perform maintenance of the activated carbon filter and softener using genuine spare parts. For specifications on the correct maintenance of the activated carbon filter and softener see the Manufacturers' manuals delivered separately.

Fresh water system diagram:

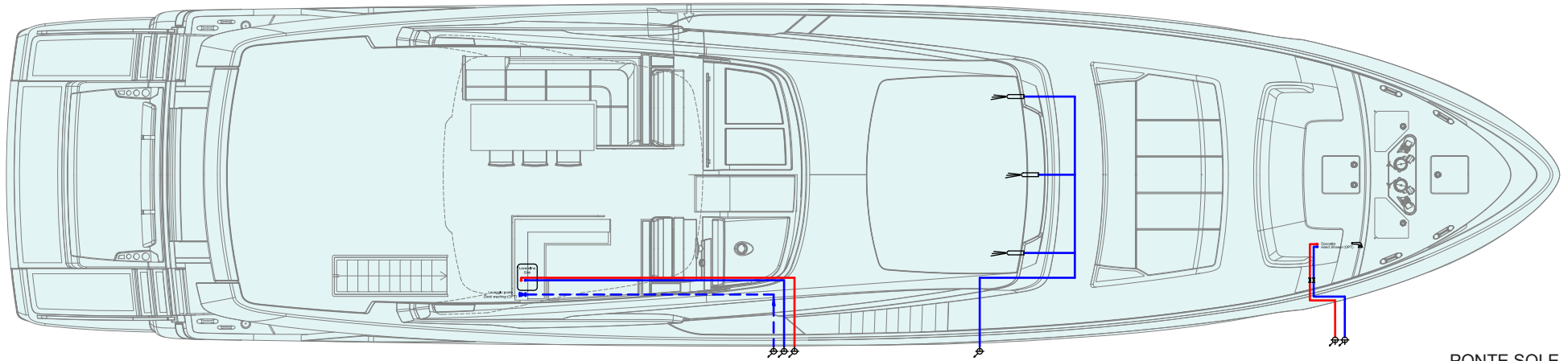



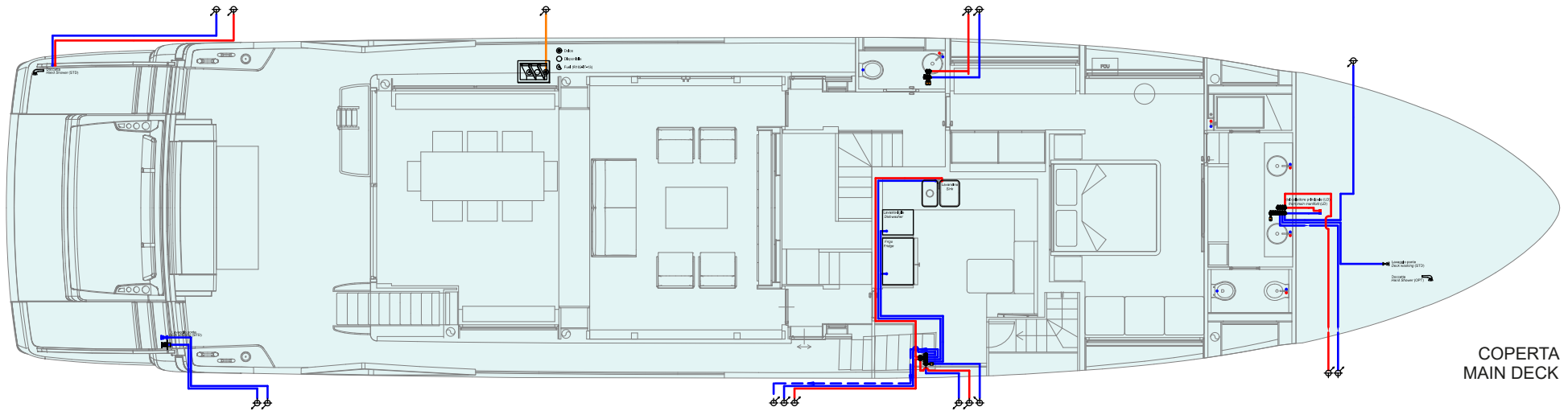



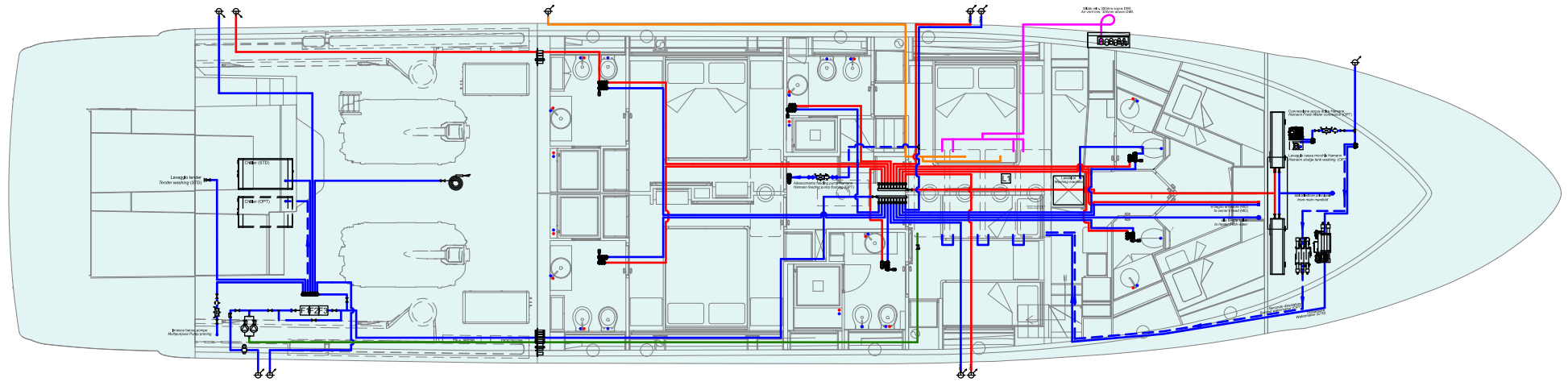





PONTE SOLE
UPPER DECK























COPERTA
MAIN DECK



PONTE SOTTOCOPERTA
LOWER DECK

ICONA ICON	DESCRIZIONE DESCRIPTION
	Al ponte superiore To upper deck
	Al ponte inferiore To loer deck
	Scarico centralizzato Centralized overboard
	Passaparatia acciaio inox Watertight bulkhead penetration
	Attacco da banchina Fresh water shore connection
	Riduttore di pressione Pressure reducer
	Valvola a sfera Ball valve
	Valvola di non ritorno Check valve
	Lavaggio ponte Deck washing
	Raccordo a T Tee
	Sistema trattamento acque nere Black water treatment system
	Pompa trasferimento Feeding pump
	Serbatoio fanghi Sludge tank

ICONA ICON	DESCRIZIONE DESCRIPTION
	Collettore valvolato Manifold with valves
	Collettore valvolato Manifold with valves
	Elettrovalvola con filtro 24V 24V solenoid valve with filter
	Ugello lavavetri Washer nozzle
	Doccetta Hand shower
	Tappo Cover
	Manichetta Hose
	Autoclave Pressurized water pump
	Dissalatore Watermaker
	Boiler Water heater
	Valvola antinquinamento Antipollution valve
	Pompa ricircolo acqua calda Hot water recirculation pump

ICONA ICON	DESCRIZIONE DESCRIPTION
	Sonda livello Fresh water level gauge
	Addolcitore Water softener
	Filtro ai carboni attivi Carbon filter
	Sterilizzatore UV UV sterilizer
	Linea acqua dolce fredda Fresh water
	Linea acqua dolce calda Hot water
	Linea imbarco acqua dolce Fresh water filling line
	Da cassa acqua dolce From fresh water tank
	Sfiato cassa acqua dolce Fresh water tank vent

6.1.1 Watermaker

To solve the problem of water supply and to ensure a constant availability also during long navigations, the yacht has been provided with an water-maker system.

The watermaker is installed in the bow locker and draws the sea water through the dedicated sea inlet using an electric pump and, after having filtered and treated it, sends it to the onboard tanks.

Before the salt is removed from it, sea water is filtered in order to remove all “suspended” particles, such as small seaweeds and impurities in the water, which could clog the inner membranes of the watermaker even very quickly.

The watermaker can produce bacteriologically pure water and, therefore, which can be used for on-board applications, further to using it for cooking. Excess water and salt concentrate are discharged overboard.

In order to prevent the problem of the deposit of salts on the inner membranes and their crystallization over time, the system has been provided with a manual flushing system which uses fresh water. Given the importance of this operation, clean the inner membranes of the watermaker according to the procedures and the schedules indicated by the manufacturer.

On the general electrical panel in the engine room, there is the relevant mag-neto-thermal switch which supplies and protects the watermaker system.



NOTE

For further information on use and maintenance, please refer to the manufacturer's manual.



CAUTION

The watermaker is to be kept in good condition by scrupulously following the indications in the specific manual. Bad maintenance can lead to production of non-potable water unsuitable for on-board use.

**CAUTION**

The watermaker does not eliminate all dangerous agents present in polluted waters (see specific manual).
Use the watermaker only in clean waters, to avoid contamination of its membranes, tanks and of the whole circuit.

**CAUTION**

In order to prevent premature clogging of the watermaker filters and membranes, do not use the system where sea water is dirty or contains suspended sand.

MAINTENANCE

At least once a month verify:

- The correct operation;
- The oil level in the pump.

Periodically perform a fresh water washing cycle.

At least once a year, change the oil of the pump.

When necessary clean the filter.

**CAUTION**

For correct instructions for use of the watermaker system, please refer to the specific manual provided by the manufacturer.

6.1.2 Cold fresh water system

The system is kept under pressure by an autoclave pump.

The pump supplies the system by drawing water from the tank; the water flowing through pipes and manifolds supplies following uses:

- Owner's bathroom;
- Port and starboard VIP bathroom;
- Port and starboard guest's bathroom;
- Service bathroom;
- Stern shower;
- Bow shower (optional);
- Galley sink;
- Windscreen wiper;
- Air conditioning unit;
- Washing machines;
- Dishwasher;
- Water heater;
- Engine room tap;
- Tanks washing tap;
- Bow tap;
- Ice maker;
- Watermaker membranes wash.

Cold water, both coming from the pump and from the shore water system, before being sent to the yacht's equipment, is filtered by an appropriate filter which retains the retaining impurities with standard filtration grade of 60 micron.

When the filter clogs, you need to clean the filter cartridge.

NOTE

For further information on use and maintenance, please refer to the manufacturer's manual.

6.1.3 Hot fresh water system

Water is drawn from the tank by means of an autoclave pump and delivered to the water heaters, which heat it.

The autoclave pump keeps the circuit under pressure continuously.

The thermostatic valves installed on the water heaters allow the setting of the hot water temperature at the taps.

In order to use hot water, it is necessary to:

- The water heater and autoclave magneto-thermals, in the main electrical panel located in the engine room, are in the ON position;
- Ensure that a power supply is connected (generator or shore);
- Make sure the user battery breaker is set to ON.

The water heaters are powered at 120/240V AC, taken from shore or from the on board power generators.

By means of a distribution manifold, the hot water is conveyed to the following uses:

- VIP cabin bathrooms;
- Service bathroom;
- Guest cabin bathrooms;
- Owner's cabin bathroom;
- Galley sink;
- Stern shower;
- Bow shower.

NOTE

For further information on use and maintenance, please refer to the manufacturer's manual.





WARNING





Water heaters are not storage heaters: wait for it to come up to temperature.

6.1.4 Maintenance fresh water system

Component	Maintenance	Notes and precautions
Fresh water tanks	Cleaning and checks	<p>At least every month, drain the fresh water tanks completely and rinse them a couple of times with clean fresh water for change completely the water stowed in the storing tanks and at the same time to wash them too.</p> <p>Periodically pour a specific disinfectant, in the quantity recommended by the Builder, into the tanks, through the intake filler, in order to prevent the formation of bacteria in the system.</p>
Electric water heater	Cleaning and checks	<div style="border: 1px solid black; padding: 5px; margin-bottom: 10px;"> <p style="text-align: center;">MAINTENANCE</p> <p>At least once a month check the operation of the water heater. At least once a month check the operation of the relief valve. At least once a year carry out the thermostat calibration, and if necessary, have it calibrated again. At least every two years descale the resistor.</p> </div> <div style="border: 2px solid yellow; padding: 10px;"> <p style="text-align: center;"> CAUTION</p> <p>If warm water is not available, because of the fresh water circuit discharge, switch OFF the water heater to prevent damaging it resistor.</p> </div>

Component	Maintenance	Notes and precautions
Fresh water system	Checks	<p>In case of need or of maintenance, by acting on the valves installed on the distribution manifolds, it is possible to cut out parts of the system or single uses, without involving the operation of the general system. Check if along the hydraulic circuit, where possible, are present leaks due to the damage of piping.</p> <div data-bbox="1137 472 2130 699" style="border: 1px solid orange; padding: 10px; margin-bottom: 10px;"> <p style="text-align: center;"> WARNING</p> <p>The high temperature can cause the softening of the pipes and the following slackening of the fittings. Always check the pipes tightening, especially those located near heat sources.</p> </div> <div data-bbox="1137 743 2130 938" style="border: 1px solid orange; padding: 10px;"> <p style="text-align: center;"> WARNING</p> <p>During the winter, if you do not use the yacht, it is advisable to drain all the circuits where there is fresh water to avoid cracks due to frost.</p> </div>

Component	Maintenance	Notes and precautions
Autoclave pump	Cleaning and checks	<p>The maintenance of the pump should be serviced by qualified personnel only, after having been disconnected from the power mains.</p> <p>No routine maintenance is required so as long as the following precautions are taken:</p> <ul style="list-style-type: none"> • In case of freezing risk, it is necessary to empty the pump body; then refill the pump before operating it but make sure the ambient temperature is higher than the water freezing temperature. • Make sure the pump never works dry. • If the pump remains unused for a long time, it is better to empty the body and clean it. • Periodically check the efficiency of valves and strainers. • To direct current motors the brushes must be periodically checked for consumption and spring pressure. <p>Protect electric components of the pump with proper products.</p> <div style="border: 1px solid black; padding: 5px; margin: 10px 0;"> <p style="text-align: center;">NOTE</p> <p>For further information on use and maintenance, please refer to the manufacturer's manual.</p> </div> <div style="border: 2px solid orange; padding: 10px; margin: 10px 0;"> <p style="text-align: center;"> WARNING</p> <p>During the winter, if you do not use the yacht, it is advisable to drain all the circuits where there is fresh water to avoid cracks due to frost.</p> </div>

Component	Maintenance	Notes and precautions
Autoclave pump	Cleaning and checks	<div data-bbox="1137 268 2128 598" style="border: 1px solid orange; padding: 5px;">  <p>WARNING</p> <p>The autoclave tank pump is self-priming but it needs though, in order to operate, to have its body filled with liquid. For a correct use, we recommend at first priming or after a long period of idling, to fill the pump body with liquid, to check the pressure inside the tank (it must have the same pressure priming the electric pump) and to verify the clockwise rotation of the pump (seen from the engine side).</p> </div> <div data-bbox="1137 646 2128 837" style="border: 1px solid orange; padding: 5px;">  <p>WARNING</p> <p>If the control panel shows the pump operating led remains always lit, but the connected uses are not in use, check for leaks.</p> </div> <div data-bbox="1137 885 2128 1141" style="border: 1px solid orange; padding: 5px;">  <p>WARNING</p> <p>When anomalous situations occur, such as lack of water or pipes clogging, it indicates the presence of faults by means of the red light "Failure" and stops the pump. By pressing red button (reset) the system restart.</p> </div> <div data-bbox="1137 1189 2128 1372" style="border: 1px solid red; padding: 5px;">  <p>DANGER</p> <p>Before carrying out maintenance on the fresh water pump, avoid its accidental priming.</p> </div>

6.2 SEA WATER SYSTEMS

The sea water systems on board are:

- **Engine cooling system**
This system consists of two circuits, one for the starboard engine and the other for the port engine. Sea water is sucked directly by the inner pumps of the same engines, by means of two sea cocks equipped with two cut-off valves and strainers. The water sucked in by the engines flows through the strainers and is then delivered to the heat exchangers of the gear boxes and to the heat exchangers of the same engines, and then discharged overboard. Moreover, suitable circuit branches cool the exhaust manifolds.
- **Generators cooling system**
Sea water is drawn in by the pump of the generators themselves through the sea cock equipped with an interception valve and strainer. The water drawn in by the generators, after passing through the strainer, is sent to the heat exchangers of the generators themselves and then discharged overboard. To discharge the water and fumes coming out of the yacht, the generators convey the exhausts through the muffler and then pass to a separator.
- **Seawater fire extinguishing/washing system**
It consists of an electric pump that sucks in seawater through a seawater intake equipped with a shut-off valve and strainer and sends it to the fire hose, as well as to the water-based functions such as the sewage tank and anchor chain washing units.
- **Air conditioning unit cooling system**
The circuits consist (one per air conditioning unit) of sea suction with shut-off valve, inspectable sea water strainers and connections for distribution to the air conditioning units.
- **Gyroscopic stabiliser cooling system**
Sea water is directly sucked by the stabilizer cooling pumps by means of a sea cock provided with cut-off valve and strainer. The water sucked in by the generator flows through the strainer and is delivered to the heat exchanger of the interceptors and then discharged overboard.



CAUTION

The watermaker should only be used in water that is definitely clean, to avoid contaminating its membranes, tanks and the entire circuit.



CAUTION

Before carrying out cleaning of the sea cock strainers, check that uses supplied with sea water are not on and used.



WARNING

It is good practice to close all sea cocks when leaving the yacht in the water for a long time.

Clean the sea cock strainers according to the schedule and to the pollution condition of the water taken on (seaweed, mucilages, etc..).

- Close the valve of the relevant sea cock (by means of the handwheel or lever).
- Cut-off valves upstream of the relevant strainer.
- Remove the strainer cover by loosening the screws.
- Remove the strainer basket and wash away all impurities with fresh water. If necessary, replace them.
- Reinstall the baskets and the cover.
- Open the valves upstream of involved strainer.
- Before restarting the system circuit, ensure that the screws and relevant washers are correctly fastened with the ring and disc on strainer's body.
- Re-open the sea cock valve completely and check for leaks presence from the strainer cover.

**WARNING**

Before carrying out maintenance on the sea water circuit, disable its operation and close the sea cock valve.

Before restarting the system circuit, make sure that the cut-OFF valve is completely open.

**WARNING**

During navigation, regularly check the cleanliness of the sea water strainer baskets.

If the yacht is crossing a dirty sea area, check the condition of the strainers and proceed with their cleaning.

Taking suitable precautions is very important to prevent damage to mechanical parts (engines, generators, etc.), discharge systems and to not jeopardize the safety of the yacht.

**CAUTION**

In case of sinking hazard, if the escaping conditions allow it, close all ball valves of the sea intakes.

**DANGER**









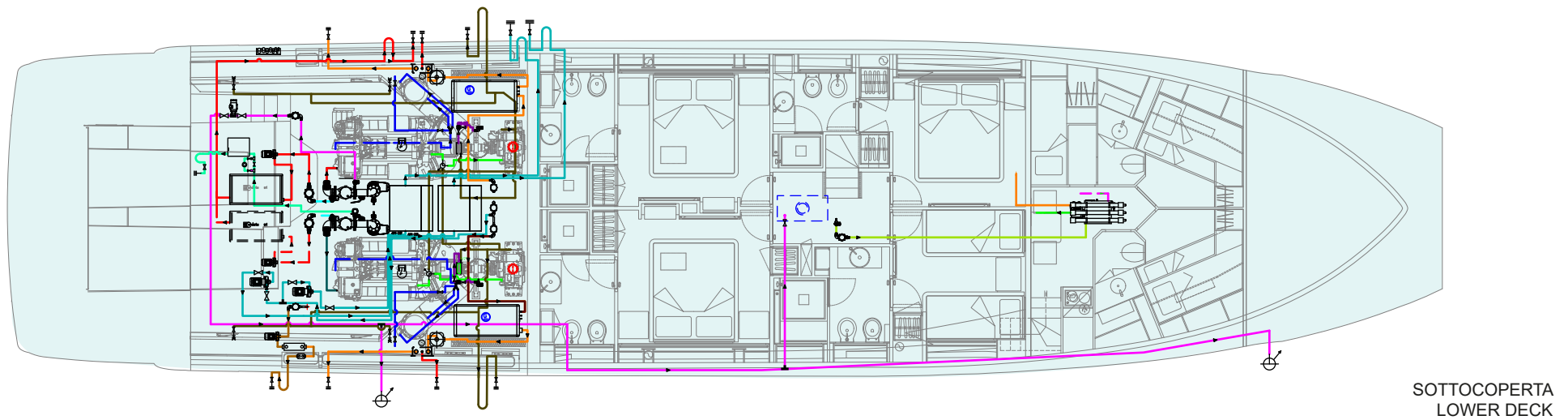
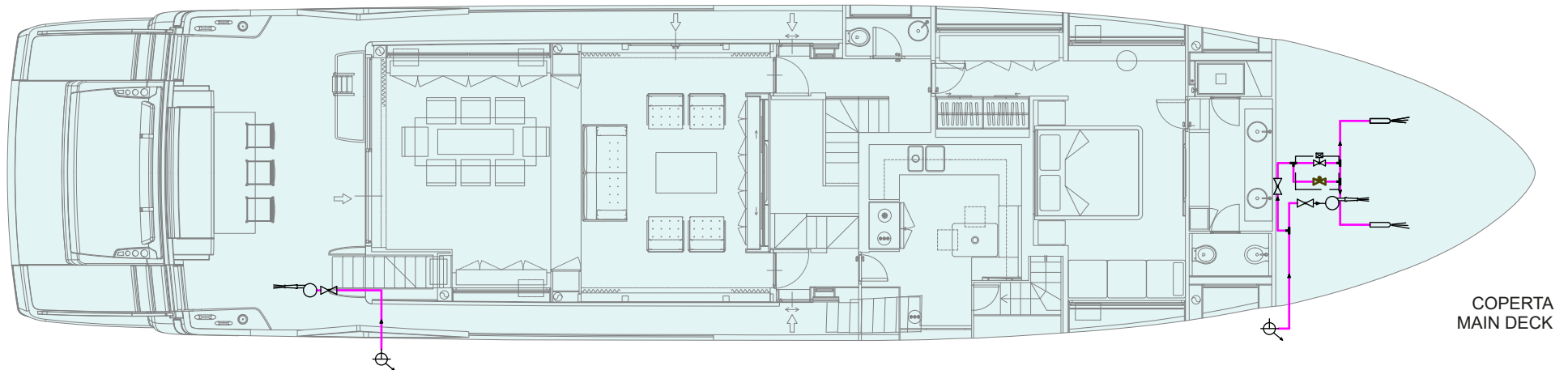



The lack of care while cleaning each sea intake strainer can cause serious damage to the on-board devices and, in some cases such as fire, it may have extremely serious consequences. Check before undertaking the navigation and at regular intervals during navigation, the condition of the strainers of the various devices through the transparent covers.





**WARNING**

It is advisable, when leaving the yacht in water for a long time, to close all seacocks.



Sea water system diagram:







ICONA ICON	DESCRIZIONE DESCRIPTION
	Motore Diesel Diesel engine
	Separatore di fumi (optional) Smoke separator (optional)
	Generatore Generator
	Silenziatore Muffler
	Invertitore Gearbox
	Valvola a sfera Ball valve
	Valvola di non ritorno Non-return valve
	Scarico a mare Sea discharge
	Scarico centralizzato Centralised discharge
	Elettrovalvola lavaggio catena Chain washing solenoid valve
	Scarico sprinkler Sprinkler discharge
	Sensore di temperatura gas motori Engine gas temperature sensor
	Filtro Strainer

ICONA ICON	DESCRIZIONE DESCRIPTION
	Linea mare motori Engine sea water line
	Linea mare generatori Gen set sea water line
	Linea mare stabilizzatore giroscopico Gyroscopic stabilizer line
	Linea mare servizi / A/C Service sea water line / A/C
	Linea mare antincendio Fire fighting sea water line
	Linea mare raffreddamento idraulica Hydraulic system cooling line
	Linea mare raffreddamento timoneiria Steering gear system cooling line
	Valvola di sovrappressione Overpressure valve

6.2.1 Maintenance of sea cocks and strainers

Component	Maintenance	Notes and precautions
<p>Sea cocks and strainers</p>	<p>Cleaning (as required depending on the shoring area, but at least every month)</p>	<p>Sea cock cleaning This operation has to be carried out outside, therefore the yacht must be in a dry shore or you can ask the intervention of a diver.</p> <ul style="list-style-type: none"> • Have the sea cocks cleaned (removal of seaweed or barnacles. If necessary have them removed with a brush). <div data-bbox="1093 544 2056 730" style="border: 2px solid red; padding: 10px; margin: 10px 0;">  <p>DANGER</p> <p>Before carrying out maintenance on the fresh water pump, avoid its accidental priming.</p> </div> <p>Inspection and cleaning valves and strainers</p> <ul style="list-style-type: none"> • Cleaning is to be carried out more frequently if the water drawn in is particularly dirty (seaweed, mucilage, etc..). <div data-bbox="1077 919 2040 1114" style="border: 2px solid orange; padding: 10px; margin: 10px 0;">  <p>WARNING</p> <p>Before removing the strainer, it is necessary to close the valve fitted to the sea cock, to prevent flooding the bilge with water.</p> </div>

Component	Maintenance	Notes and precautions
Seacocks and strainers	Cleaning (as required depending on the shoring area, but at least every month)	<p>Inspection and cleaning valves and strainers:</p> <ul style="list-style-type: none"> • Check for barnacles or corrosion on the control levers of the cut-OFF valves of the strainer to be checked. • Clean the control levers of the valves with a brush. • Move the levers repeatedly. • Close the cut-OFF valve upstream the strainer. • Remove the strainer cover by loosening the screws. • Remove the filter element, clean it with a brush and rinse it in water (replace as necessary). • Clean the strainer housing. • Check and, if necessary, replace the gasket of the strainer cover. • Fill the strainer with water to avoid the pumps running dry or that the system does not prime. • Reposition the strainer, the cover and tighten the nuts. • Reopen the cut-OFF valve and check whether the strainer cover is leaking. <div style="border: 1px solid orange; padding: 10px; margin: 10px 0;"> <p style="text-align: center;"> WARNING</p> <p>Before servicing the sea water lines, disable the operation of the connected uses. Before restarting the uses, make sure that the cut-OFF valve is completely open.</p> </div> <div style="border: 1px solid orange; padding: 10px; margin: 10px 0;"> <p style="text-align: center;"> WARNING</p> <p>During navigation, regularly check the cleanliness of the sea water strainer baskets. If the yacht is crossing a dirty sea area, check the condition of the strainers and proceed with their cleaning. Taking suitable precautions is very important to prevent damage to mechanical parts (engines, generators, etc..), discharge systems and to not jeopardize the safety of the yacht.</p> </div>

Component	Maintenance	Notes and precautions
Electric pump	Cleaning and checks	<p>At least each week, check the operation of the sea water pump.</p> <div data-bbox="1077 325 2042 724" style="border: 2px solid orange; padding: 10px; margin-bottom: 10px;"> <p style="text-align: center;"> WARNING</p> <p>The pump is self-priming but, in order to operate, it needs to have its body filled with liquid.</p> <p>For a correct use, we recommend at first priming or after a long idling period, to fill the pump body with liquid and to verify the rotation direction of the pump (it should be clockwise, seen from the engine side).</p> <p>Besides, if on the control panel the pump operating led remains always lit, but the connected uses are not in use, check for leaks.</p> </div> <div data-bbox="1077 767 2042 924" style="border: 2px solid red; padding: 10px; margin-bottom: 10px;"> <p style="text-align: center;"> DANGER</p> <p>Before servicing the pump, disable its operation.</p> </div> <ul style="list-style-type: none"> • Have the inner cleanliness of the pump checked; possibly, have it cleaned with well diluted detergent and dried. • Have the fittings for well tightening and corrosion checked. • Frequently check and keep the suction filter clean. • Check that the electric power supply cables are in good conditions. • For further information, see the Manufacturer's Manual.

6.3 GREY WATER SYSTEM

The water discharged by the showers and the washbasins is collected into a grey water tank placed at mid yacht.

It can be inspected by lifting the flooring of the VIP's cabins, and is connected to the draining pump at automatic or manual control located in the engine room.



ENVIRONMENT

Do not discharge soaped waters drained by washing machines and dishwashers in the harbour, inside marinas or near beaches, because of the large amount of foam produced.

The grey water pump is controlled from the bridge control panel.

The pump, in automatic operation, starts operating when the level reaches the float and is deactivated by means of a timer. It has to be remembered that the float inside the grey water tank is equipped with a circuit delaying for some second, both the pump switching ON and OFF.

The start delay prevents that, in case of yacht rolling, the pump primes with the wake.

The switching OFF delay ensures that the pump sucks also the residual liquids below the float level.

Waste water is discharged overboard through a central drain located in the engine room.

In manual mode, the waste water pump can be operated via a switch located on the control panel on the bridge.

NOTE

We recommend to monitor constantly the tank level, by checking the warning lights of the synoptic panel, or, to drain the tank manually, before entering the harbour, to avoid returning to open sea for tank draining.

Condensate of fan coil is collected in special boxes and discharged directly overboard.

MAINTENANCE

At least once every three months:

- Carry out the complete cleaning of the tank;
- Carry out the complete cleaning of the pump;

At least once every six months check the status of the pump.



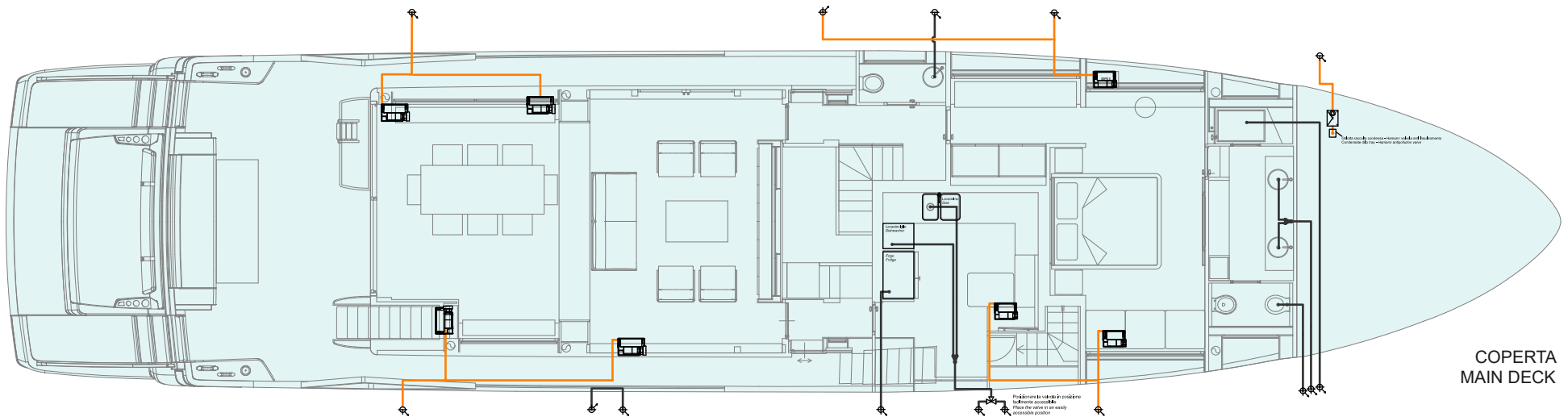
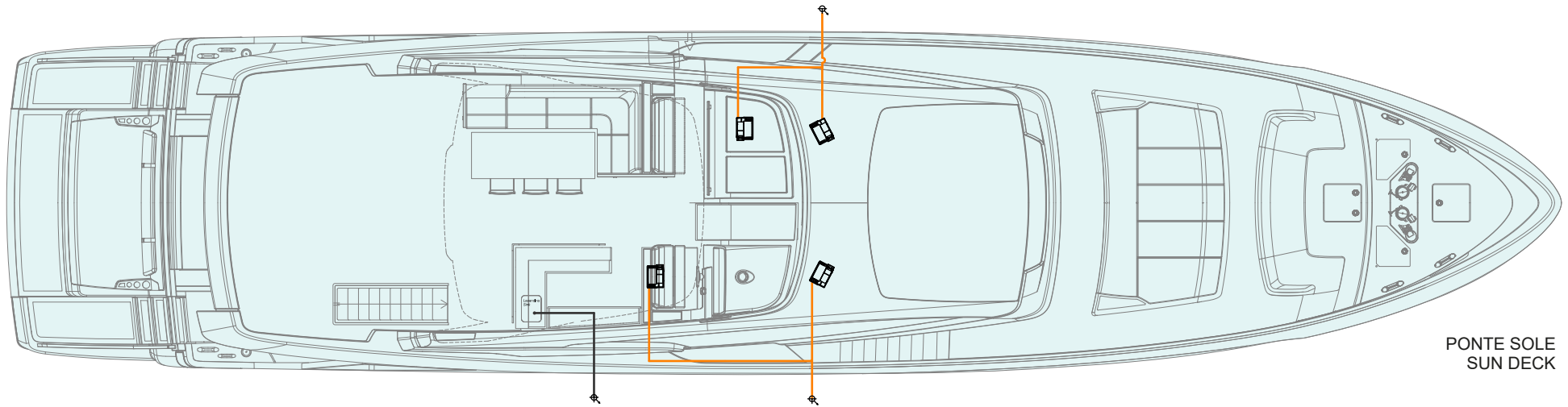

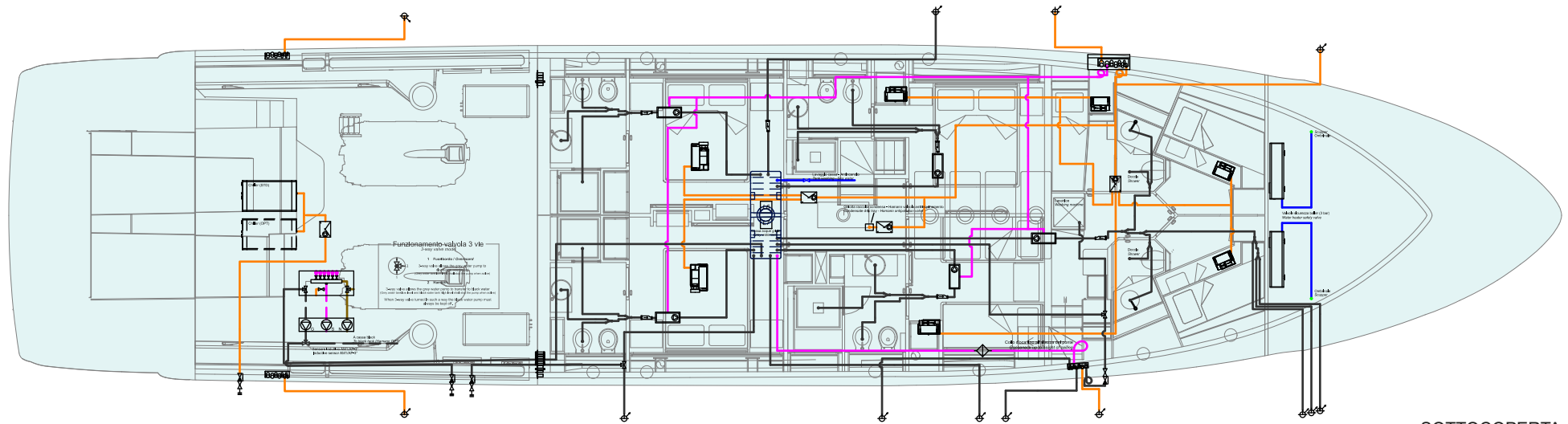



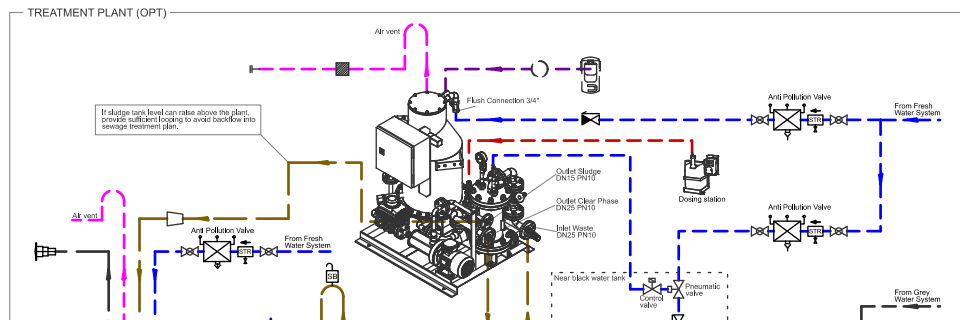



Grey water system diagram:





























SOTTOCOPERTA
LOWER DECK



ICONA ICON	DESCRIZIONE DESCRIPTION
	Al ponte superiore To upper deck
	Al ponte inferiore To lower deck
	Scarico centralizzato Centralized overboard
	Passaparatia acciaio inox Watertight bulkhead penetration
	Flangia pump out Pump out flange
	Valvola a sfera Ball valve
	Valvola di non ritorno Non return valve
	Valvola a 3 vie 3 way valve
	Tee Tee
	Y Y
	Collettore Manifold
	Fan coil Fan coil unit
	Sifone antiodore Odor removing siphon

ICONA ICON	DESCRIZIONE DESCRIPTION
	Fuori bordo Overboard
	Antisifone Siphonbreak
	Gruppo polivalente Multipurpose pump
	Filtro anti odori No-smell filter
	Livellostato a tre contatti Three contact sensor
	Livello cassa acque nere Black water level
	Livellostato cassa acque nere Black tank Level
	Livellostato cassa fanghi Sludge tank level
	Livellostato acciaio Steinless steel level
	Livellostato a 3 contatti Three-contact sensor
	Sonda di livello acque grigie Grey water level gauge
	Serbatoio accumulo ac Compressed air accumulation tank
	Cassetta raccolta condensa Condensation pumping unit

ICONA ICON	DESCRIZIONE DESCRIPTION
	Compressore Air compressor
	Pompa trasferimento Feeding pump
	Impianto trattamento acque nere Black water treatment system
	Serbatoio fanghi Sludge tank
	Unità di dosaggio Dosing unit
	Cassetta raccolta acque grigie Grey water pumping unit
	Linea acque grigie Grey water
	Linea drenaggi fan coil Fan coil drainage
	Linea acque nere Black water
	Linea aria compressa Compressed air
	Linea morchie Hamann Hamann sludge
	Sfiato cassa acque grigie Grey water tank vent

6.4 BLACK WATER SYSTEM

The system consists essentially of a tank and a black water pump which drains overboard.

The water used to wash the toilets is taken from the cold-water circuit through the distribution manifolds.

The solenoid valves relevant to each WC are installed on the manifolds; they allow the flush of water each time the buttons "BEFORE USE" or "AFTER USE" are pressed.

Each toilet has a macerated pump conveying black waters into the holding tank. The tank is located in the bilge under the cabins corridor.

The cover of the sewage tank can be inspected from the bins in the access corridor to the guest cabins.

A pump located in the engine room empties the tank via a suction line which discharges directly into the sea through a drain below the waterline.

The tank can be emptied via the outlet on the right-side walkway and using the shoreside suction.

The pump has two operating modes, Automatic and Manual, which can be selected by means of the control on the synoptic panel.

In "Automatic" mode, reaching the mid-level threshold triggers the pump, which remains active until the low level threshold is reached.

To start the pump in "MANUAL" mode, press the button on the bridge control panel.

The pump remains active until the low level is reached.

If the level is lower than the low level, the pump will not start, not even pressing the "MAN" button..



CAUTION

Within 12 nautical miles from the coast it is forbidden to discharge the black water tank into the sea; it is necessary to keep the discharge pump inactive and to exclude the automatic activation.

On the synoptic panel of the main helm station, there are the warning lights of full-tank WC-disabled, full-tank pre-alarm and manual or automatic activation control of tank drain

The discharge of black water from the shore directly into the sewer system properly is the solution of minimal environmental impact to be taken whenever it is moored in place and equipped.



CAUTION

Before leaving port, check the level indicators of the sewage water tank on the bridge in order to suction from the shoreside if necessary.

Procedure for emptying through the shoreside nozzle.

- Handle the hose by paying attention not to soil the deck teak, and dampen it ahead of time.
- Correctly insert the shoreside drainage nozzle.
- Take advantage of harbour services for sewage intake with vacuum system.
- Once the operation is completed, disconnect the hose correctly by paying attention again so as not to soil the deck teak. If necessary, rinse.

Before entering shore, you should check the tank level and decide whether you should discharge at sea or use the port facilities by checking in advance if your destination shore is equipped for tank emptying via the nozzle.

To increase the reliability and safety of the system, in case of a fault in the black water pump, it is possible to drain by means of the grey water pump. Under such conditions, it is necessary to ensure the proper opening of the concerned manifold valves.

**CAUTION**

During the suction black water from the shore is strictly prohibited to:

- Use the toilet;
- Press the command button then operate the pump discharge overboard.

**WARNING**

Press the command button then operate the pump discharge overboard:

- To enable services, if necessary, setting to ON the toilet magneto-thermal switch on the general electrical panel in the engine room;
- The absence of the red light high-level holding tank.

**CAUTION**

We recommend regularly monitor the level black water from monitoring system panel (Levels) to achieve optimum use of the retention system in compliance with environmental regulations locally in force.

**CAUTION**

In case of sinking hazard, if escaping condition allow you this, close the ball valve of the black water drain.

**CAUTION**

Totally empty the system and the black water tank before the lay-up period in order to prevent any problems with freezing.

**CAUTION**

For all pleasure crafts, drain at sea of on-board toilets is forbidden inside harbours, landings and moorings dedicated to crafts' anchor riding, and also within the limit of beaches visited by swimmers, as stated in the single regulations of the Port Authorities.

**CAUTION**

Direct sea discharge can only be carried out in the event of an emergency.

The holding tank is equipped with a sea water washing system.

In order to wash the tank, you have to open the valve concerned, located on the tank door, and start the concerned pump.

This operation has to be performed periodically at a variable time interval, according to the use of the tank.

In addition to this, we recommend constantly checking the filling of the tank, so as to disconnect the pump when necessary.

**WARNING**

The valve for washing the holding tank must always be closed, except for during washing operations.
If the valve remains open, the tank can be flooded and sea water can be boarded.

**WARNING**

The holding tank washing must be performed only in compliance with legislation in force, in the harbour, only under provided it is connected to the disposal facilities on land.

**WARNING**

When using chemical products, follow the manufacturer indications meticulously and use the suitable protection devices.

**DANGER**

Holding tank washing must be performed by experienced personnel and followed carefully until the tank is empty.
An excessive pump operation can cause the intake of a large quantity of water with consequent overfilling and bilge flooding.

Your yacht can be equipped with a sewage treatment system installed in the bow technical room.

The sewage treatment system is responsible for separating the muddy part from the liquid part of the sewage.

The muddy part is stored inside a dedicated tank installed in the forepeak.

NOTE

For further information on use and maintenance, please refer to the manufacturer's manual.

Sewage system diagram:

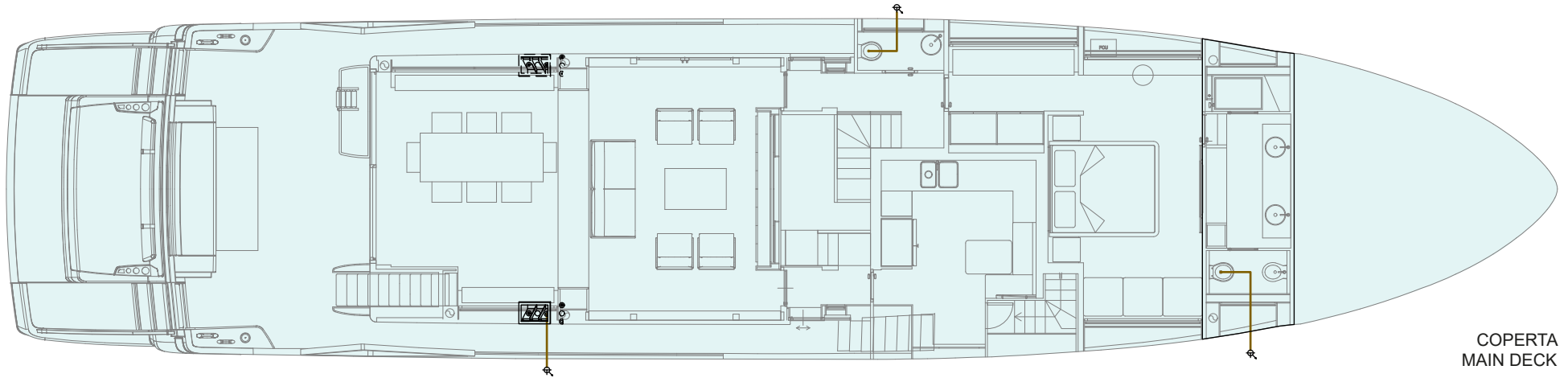



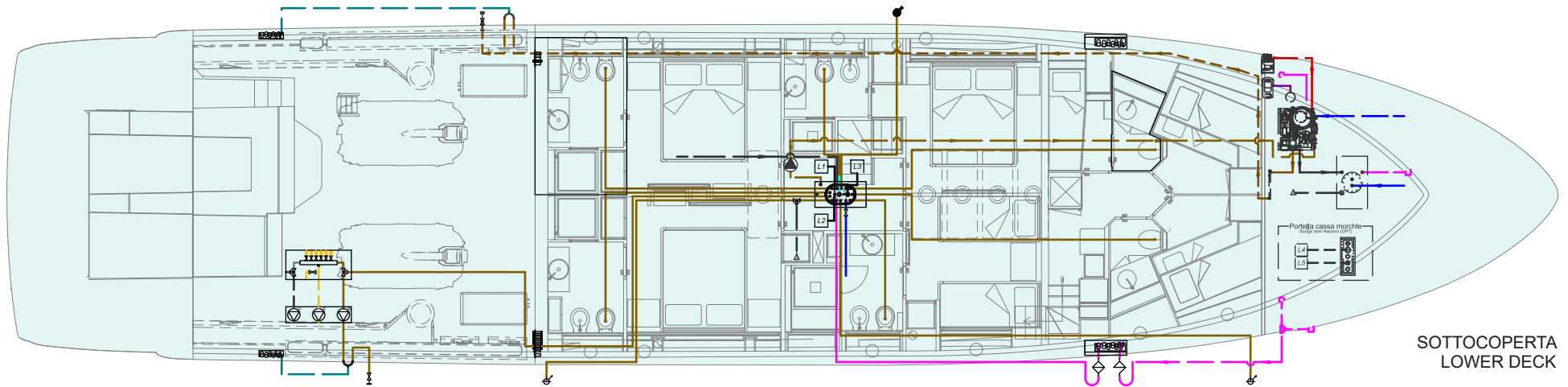



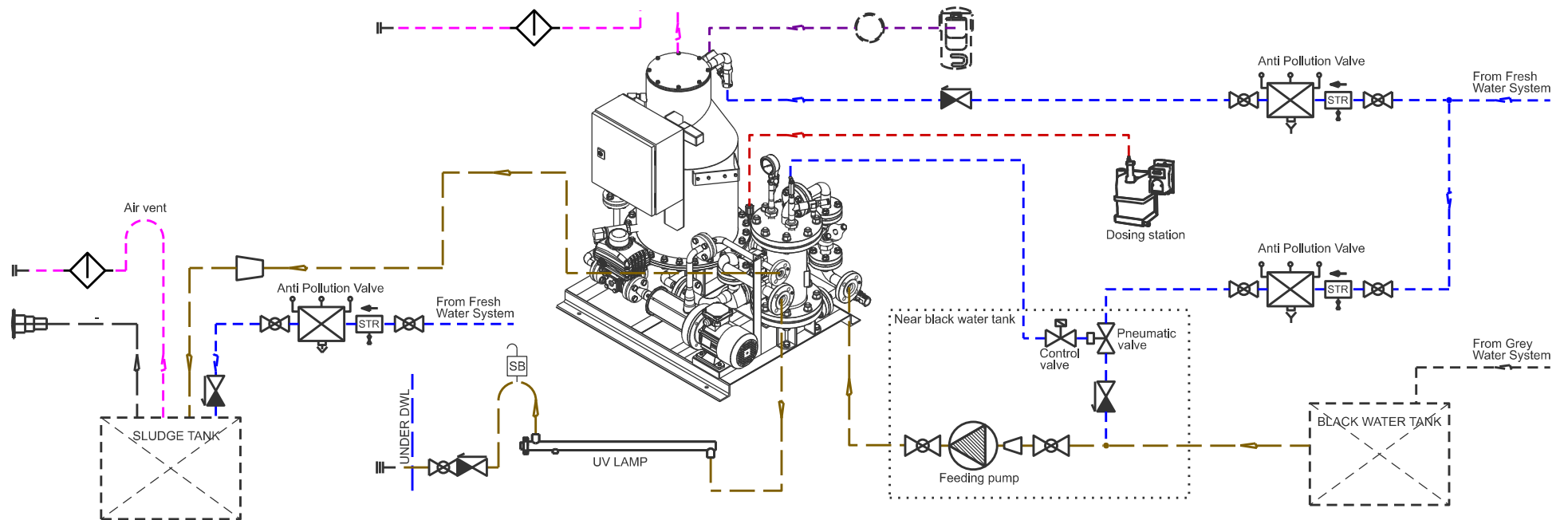















COPERTA
MAIN DECK





SOTTOCOPERTA
LOWER DECK



ICONA ICON	DESCRIZIONE DESCRIPTION
	Valvola di non ritorno Non return valve
	Valvola a sfera Ball valve
	Filtro anti odori No-smell filter
	Compressore Air compressor
	Fuori bordo Overboard
	Livellostato a tre contatti Three contact sensor
	Valvola a 3 vie 3 way valve
	Al ponte superiore To upper deck
	Al ponte inferiore To lower deck
	Scarico centralizzato Centralized overboard
	Passaparatia acciaio inox Watertight bulkhead penetration

ICONA ICON	DESCRIZIONE DESCRIPTION
	Livello cassa acque nere Black water level
	Livellostato Level
	Sensore a tre contatti Three-contact sensor
	Sonda di livello acque nere Black water level gauge
	Livellostato a 3 contatti Three-contact sensor
	Sonda di livello acque grigie Grey water level gauge
	Serbatoio accumulo ac Compressed air accumulation tank
	Tee Tee
	Y Y
	Collettore Manifold
	Fan coil Fan coil unit

ICONA ICON	DESCRIZIONE DESCRIPTION
	Antisifone Siphonbreak
	Pompa trasferimento Feeding pump
	Impianto trattamento acque nere Black water treatment system
	Gruppo preassemblato Assembled pumps
	Serbatoio fanghi Sludge tank
	Flangia pump out Pump out flange
	Unità di dosaggio Dosing unit
	Cassetta raccolta acque grigie Grey water pumping unit
	Cassetta raccolta condensa Condensation pumping unit
	Sifone antiodore Odor removing siphon

6.4.1 Toilet operation

The bathroom toilets are made of ceramic and their control panels contain two backlit buttons:

1. Button "BEFORE USE"
2. Button "AFTER USE"

After 2 minutes of service the backlit buttons 1 and 2 switch OFF and the device sets to energy saving mode.

Approaching the hand to the panel, the backlight will be restored and the operation panel.

In case of alarm for a full tank, the two button icons are illuminated permanently. To clean the surface of the panel, you can turn it OFF by pressing briefly one of the two buttons. This prevents the accidental activation of the toilet control.

NOTE

For further information on use and maintenance, please refer to the manufacturer's manual.



CAUTION

We suggest not to use the **residential function** of the WC, as the water inside the WC could splash out and wet the floor due to the yacht's rolling.



CAUTION

Other than organic waste, only very thin toilet paper can be discharged into the sea toilets. Paper tissues or handkerchiefs and sanitary napkins may clog and damage the sanitary system.

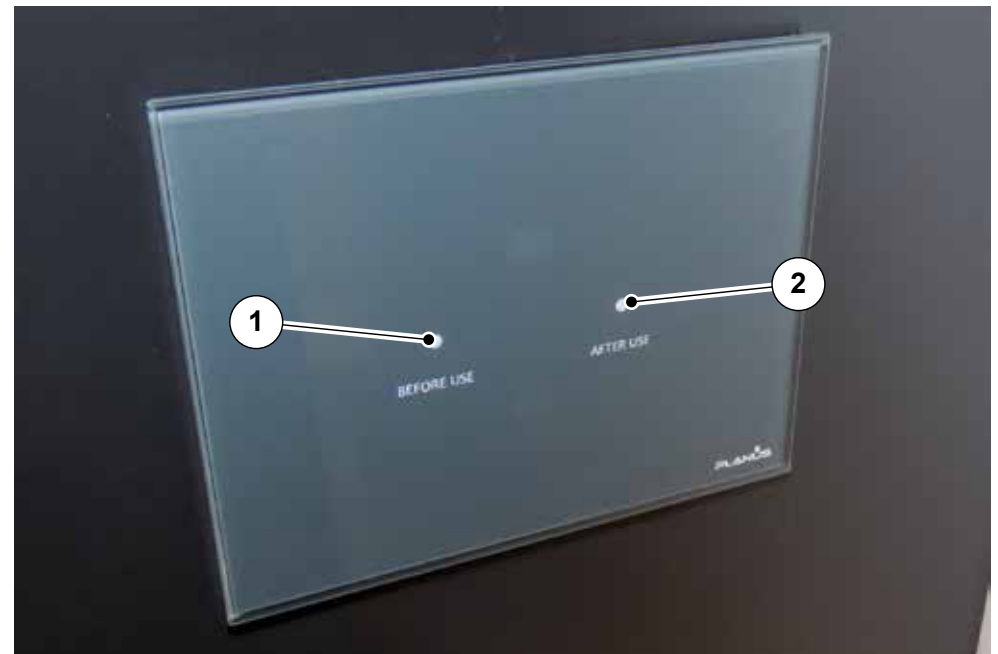



CAUTION

Make sure that toilets are electrically powered and that the black water system is operating before using them.



CAUTION

Forcing the toilet discharge can cause overflow of the tank.



CAUTION



The full tank condition is indicated by the red icon light.





CAUTION

The disabling of toilet drain protection can cause the tank to overflow.

6.4.2 Maintenance of black and grey waters draining system

Component	Maintenance	Notes and precautions
<p>Holding and grey water tanks</p>	<p>Rinse the tanks (at least every month)</p>	<p>Have the tanks filled with clean water and drain them two or three times. To prevent the formation of bacteria and of bad smell, pour periodically a disinfectant into the toilet, sink and bidet drains.</p> <div style="border: 1px solid yellow; padding: 10px; margin: 10px 0;"> <p style="text-align: center;"> CAUTION</p> <p>When using deodorants or disinfectants, avoid abrasive substances or acids, because they could damage tubes and seals.</p> </div> <div style="border: 1px solid yellow; padding: 10px; margin: 10px 0;"> <p style="text-align: center;"> CAUTION</p> <p>In case of need, break or pollution of the tanks, they can be replaced. Contact the RIVA After Sales & Service Department.</p> </div> <div style="border: 1px solid gray; padding: 10px; margin: 10px 0;"> <p style="text-align: center;">MAINTENANCE</p> <p>At least once a week check the correct operation:</p> <ul style="list-style-type: none"> • Of toilets; • Of the black water pump. <p>At least once every three months check the status of the tubes and connections.</p> <p>At least once every six months protect with proper products:</p> <ul style="list-style-type: none"> • Of toilets solenoid valves; • The black waters pump. <p>When necessary, at least once a year, carry out the accurate cleaning of the holding tank.</p> </div>

Component	Maintenance	Notes and precautions
Pumps	Replacement of impeller and mechanical seal	<p>This is a complex operation and should only be undertaken by skilled personnel.</p> <div style="border: 2px solid yellow; padding: 10px; margin: 10px 0;"> <p style="text-align: center;"> CAUTION</p> <p>The electric motor may become hot when running (see manual of the electric pumps). Pay attention. The electric pump must only be repaired by competent or qualified personnel, using manufacturer's spares; if this procedure is not followed, the manufacturer is relieved of any responsibility and warranty is void and null.</p> </div>

Component	Maintenance	Notes and precautions
Pumps	Operation check and cleaning (at least every month)	<p>Electric pumps usually do not need ordinary maintenance, as long as some precautions are taken, which extend their lives (address to the pumps' Manufacturer).</p> <div style="border: 2px solid red; padding: 10px; text-align: center;">  <p>DANGER</p> <p>Before each intervention make sure that voltage is disconnected and that there is no possibility of accidental connection.</p> </div> <ul style="list-style-type: none"> • If there is a risk of freezing, it is necessary to empty the pump casing from the liquid and to fill it, before restarting the pump. • Make sure that the pump never runs dry. • The DC motor brushes must be periodically checked for consumption and spring pressure. • If the pump does not work for a long time, it is better to empty the pump casing and clean it. • If a strainer and a foot valve are installed, check periodically for their efficiency and cleaning. • Check that the impeller is jammed, this could cause heavy damages to the electric motor; if this happens, descale the impeller and pump body. • At least once a month, have the operation of the grey/black water pumps checked, having their tanks filled with clean water until the pump activates and having the correct overboard draining checked.

6.5 BILGE AUTOMATIC SUCTION SYSTEM

6.5.1 Main bilge system

The pumps for bilge suction, driven by suitable floating switches, suck water from the bilge and send it to the overboard discharges positioned on the bulwarks.

Another float for alarm activation, located a little higher than the first one, actuates the acoustic alarm in the engine room.

The pumps are connected directly to the batteries and can be operated also when the battery master switch is set to OFF and provide water drain at any time (hold the magneto-thermal switches of the main electrical panel in the ON position).

The suction of the pumps are equipped with net strainers, whose purpose is to prevent the penetration inside the circuit of foreign bodies, which may damage or inhibit the pump or cause pipe clogging.

The bilge pumps can operate both in automatic mode, thanks to the float switches and in manual mode.

To activate the pumps manually, press the relevant buttons, located on the synoptic panel of the main helm station. To activate the bilge pumps, switch on the relevant magneto-thermal switches located on the main electrical panel in the engine room.



CAUTION

In case of emergency it is possible to suck the bilge water in the engine room through the sea pumps placed on each engine.

Should the bilge pumps of the engine room as well as not be able to drain the bilge water, the engine room is equipped with the bilge emergency draining system, operating by means of valves with manual activation, allowing to use the sea water pumps of the propulsion engines, as draining pumps. In case of emergency, use the handwheels of both valves, taking the valves to the emergency position; the suction of the pumps, driven by the engines, is now directly diverted towards the bilge.

Should it be necessary to use this draining system, the bilge level must be checked continuously, because in case of complete drainage, the engines will not be cooled down.



DANGER SINKING RISK

Make sure the pump is working properly.



CAUTION

In case of engine room bilge suction by engines: be careful to put the engine valves back in the sea water suction position when the water level in the engine room bilge is under control so as not to impair the engine components.

**WARNING**

Keep the bilge dry to allow the detection of water and to reduce the risk of slipping, as well as creating a less aggressive environment for the fixtures.

Remove any rags or other residues from the bilge, to prevent any clogging of the pump intakes, causing serious damage to the pumps and impairing the safety of the yacht.

**CAUTION**

In case of engine room bilge suction by engines: be careful to put the engine valves back in the sea water suction position when the water level in the engine room bilge is under control so as not to impair the engine components.

**WARNING**

The system total capacity is not designed for yacht draining in case of leaks.

**ENVIRONMENT**

Possible oil or fuel spilled in the bilge must be collected and stowed. It is forbidden to discharge bilge water mixed with oil or diesel fuel into the sea, because this can cause pollution.

During the maintenance operation in the engine room, it is compulsory to disconnect the magneto-thermal switches of the bilge pump automatic suction system, avoiding in this way accidental spillages of liquids and consequently sea water pollution.

**ENVIRONMENT**

Sea discharge of oils and fuels is prohibited.

**WARNING**

The main suction line operates in automatic/manual mode, while the secondary line operates only manually with the centralized pump. All pumps can be cut-OFF to prevent possible accidental discharges.

Bilge system diagram:

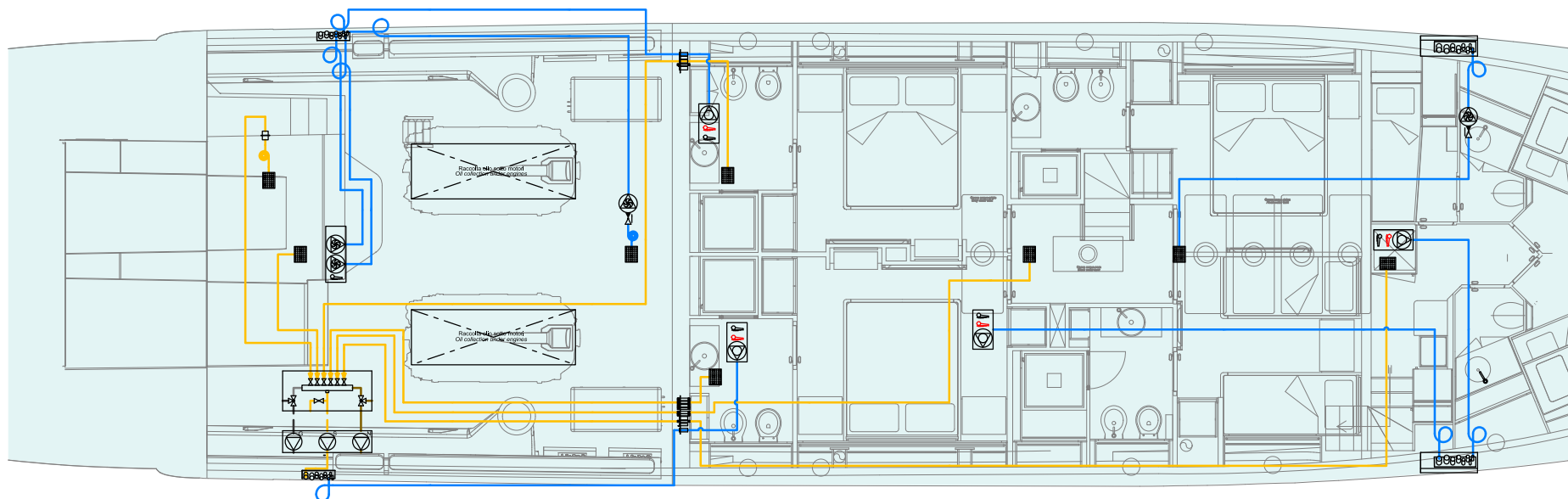

ICONA ICON	DESCRIZIONE DESCRIPTION
	Valvola a sfera Ball valve
	Valvola di non ritorno Check valve
	Scarico centralizzato Centralized discharge
	Passaparatia acciaio inox Watertight bulkhead penetration
	Pompa Pump
	Succhierola Suction strainer

ICONA ICON	DESCRIZIONE DESCRIPTION
	Gruppo polivalente Multipurpose group
	Pompa a girante Impeller pump
	Interruttore livello galleggiante: Innesco pompa Float level switch: Pump priming
	Interruttore livello galleggiante: Allarme Float level switch: Alarm

ICONA ICON	DESCRIZIONE DESCRIPTION
	Linea a banco pompe To pumps line
	Linea fuoribordo Overboard line

6.5.2 Maintenance of bilge automatic suction system

Component	Maintenance	Notes and precautions
Bilge pumps	Operation check Bilge pump operation check	As shown in the following sequence.
Non-return valves	Operation check	<div style="border: 1px solid black; padding: 10px;"> <p style="text-align: center;">MAINTENANCE</p> <p>At least once a week check the operation of pumps and floaters. At least once a month:</p> <ul style="list-style-type: none"> • Check the condition of connections; • Carry out an accurate cleaning of pumps and floaters; • Carry out an accurate cleaning of the bilge. <p>At least once every six months check the presence of clogging in the piping.</p> </div>

Operation check:



DANGER

Before each intervention make sure that voltage is disconnected and that there is no possibility of accidental connection.

Check that the pump shaft turns freely (this is possible by inserting a screwdriver in the back end of the engine shaft).

Fill the pump body with liquid so as to allow the pump to prime. This operation is very important and must be carried out at the first pump start and each time the pump body is empty, to avoid pump damaging.

Check the rotation direction, that the pump motor works within its output range and that the absorbed current is not higher than that one indicated in the tag.

These pumps, normally, do not need ordinary maintenance, provided that some measures are taken which extend their operation.

- Make sure that the pump never runs dry.
- The brushes, on DC motors, must be checked at regular intervals.
- If the yacht must remain inoperative for a long period, it is advisable to drain the pump body and to clean it.
- If a strainer and a foot valve are installed, check periodically for their efficiency and cleaning.
- Check that the impeller is jammed, this could cause heavy damages to the electric motor; if this happens, descale the impeller and pump body.

Bilge pump operation check

- Have the operation of each bilge pump checked, having the bilge filled with clean water up to the activation of each pump and having the correct draining overboard checked.
- Have the operation of each bilge pump checked even the manual one (at checks end the pumps switches must be on "AUTO").

**CAUTION**

Never run the electric pumps dry.

**CAUTION**

Check all bilge pump operation at regular intervals. Clean the pump intakes.

Non-return valves:

The on board hydraulic system consists of check valves (or non-return valves) "EUROPE" type (1) and "CLAPET" type (2).

Their maintenance, only the extraordinary one, is due to their lack of operation, which can be caused by a foreign body inside the valve itself, or by a mechanical break; in both cases, check the failure, if it is not removable, carry out the replacement.

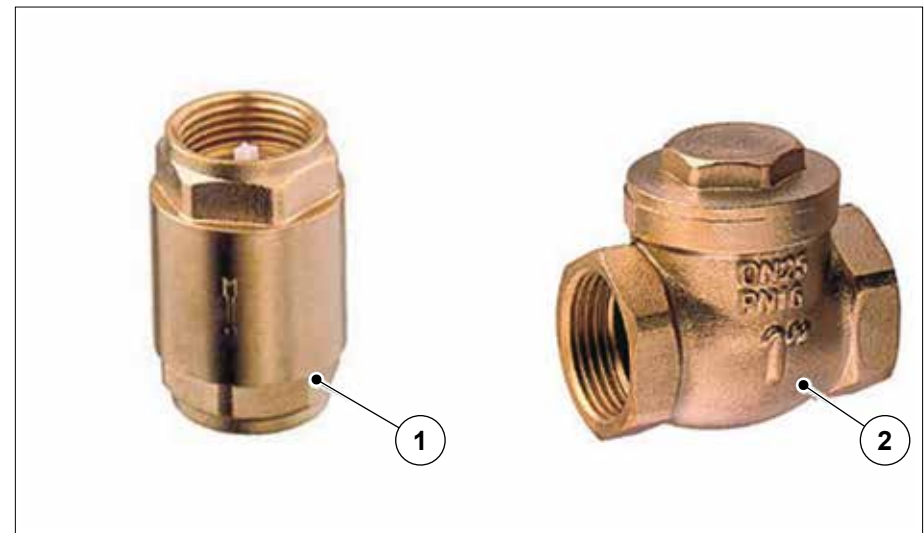

6.5.3 Multipurpose pump system

The yacht is equipped with a multipurpose pump 90l/min, which can be used, in case of emergency, to help or to replace the various automatic bilge pumps, in order to drain water from the bilge.

The multipurpose pump, activated manually, by correctly shunting the valves on the relevant manifold, can replace the following pumps:

- The black water pump;
- The grey water pump;
- The automatic bilge pumps.

In case of failure of black or grey water pumps, the multipurpose pump replaces the suction of one of the two pumps, by means of two deflecting valves installed on the multipurpose pump manifold.



CAUTION

After the use of the multi-purpose pump, it is advisable to carry out a check of the impeller. For the procedure ask the RIVA After Sales & Service Department.



CAUTION

To use the multipurpose pump, activate the magneto-thermal switch located on the general electrical panel.



ENVIRONMENT

The bilge drains can be discharged at sea only if they do not contain polluting substances.

If polluting agents are present in the bilge waters, dispose of them using the suitable containers for polluting agents located in harbours.



CAUTION

Never run the electric pumps dry.

6.6 SCUPPERS SYSTEM

The scupper system, by means of appropriate holes and drains, allows the quick offboard flow of rain water, marine water or of other nature water, that may fall on main deck or on the sun-deck.

All waters collected by the scuppers are conveyed by means of manifold tubes, placed along the bulwarks.

The total or partial clogging of one or of more scuppers must absolutely be prevented, because it is a cause of flooding and consequent loss of stability by the yacht and its structures.



CAUTION

Always check the correct water flow towards the scuppers.
The partial or total clogging of one or more scuppers is a possible cause of damage for the yacht structure and of loss of stability.



CAUTION

Avoid that incorrectly stowed objects clog the scuppers.

Scuppers system diagram:

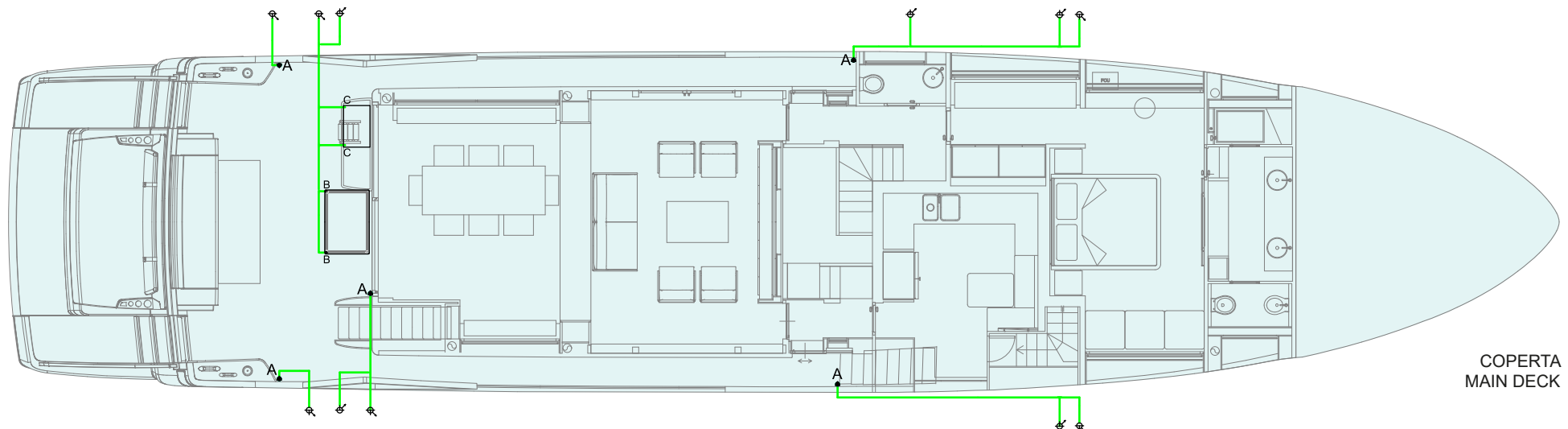
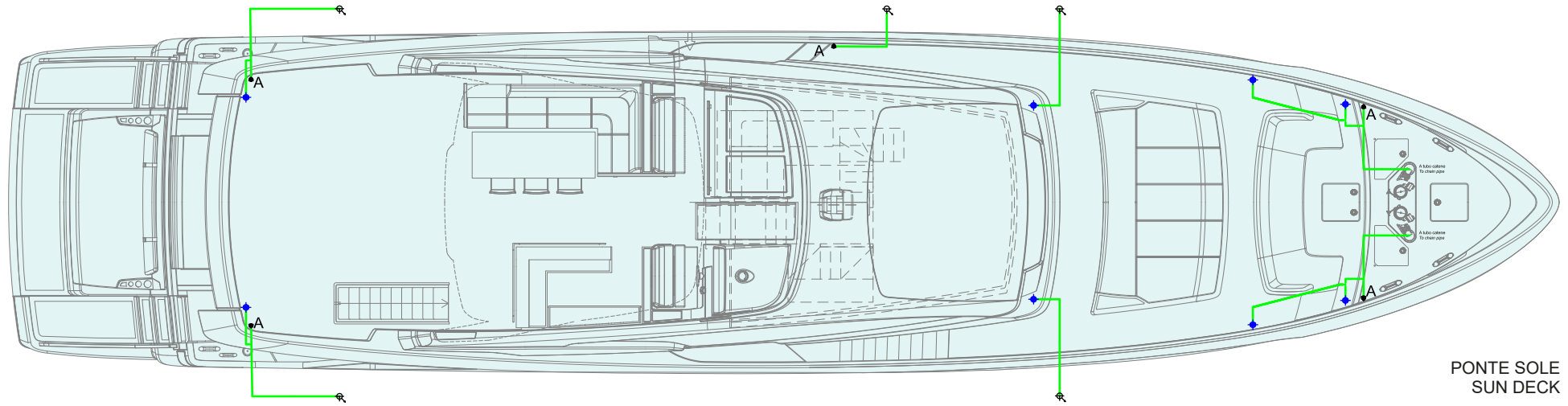

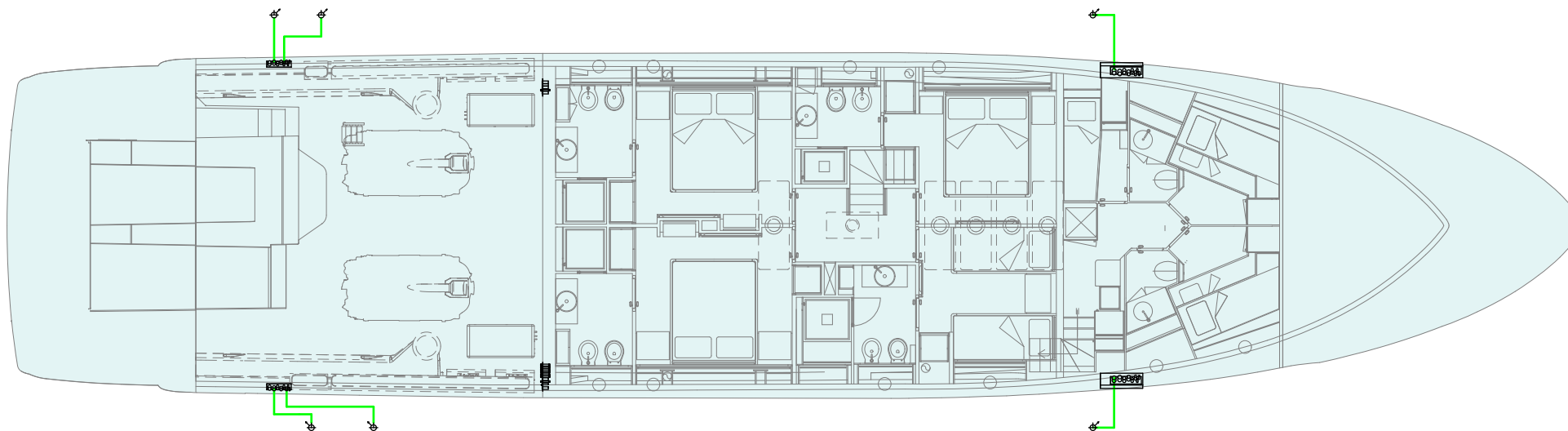

ICONA ICON	DESCRIZIONE DESCRIPTION
	Al ponte superiore To upper deck
	Al ponte inferiore To lower deck
	Scarico centralizzato Centralized discharge

ICONA ICON	DESCRIZIONE DESCRIPTION
	Fuoribordo Overboard
	Valvola a sfera Ball valve
	Valvola di non ritorno a clapet Check valve

ICONA ICON	DESCRIZIONE DESCRIPTION
	Valvola 3 vie 3 way valve
	Connessione di raccordo Junction connection
	Tubazione flessibile Flexible hoses

Riva

102 CORSAARO *supera*

ELECTRIC SYSTEM

CHAPTER 7

7.1 ELECTRIC SYSTEM

The electrical system of your yacht has been designed with the utmost attention to the SAFETY of you and your guests and has been made using materials of excellent quality and is fully compliant with current legislation.

The design and construction of the system have been carried out in compliance with current regulations.

The electrical system installed on board has been designed and built-in compliance with current regulations, based on the following criteria:

- All wiring, joints and line-feed protection devices such as magneto-thermal switches, RCCBs and fuses have been collected and grouped both within and on the front plates of the various on-board electrical panels.
- All electrical lines are oversized, ducted and/or inspectable and implemented with flame-retardant cables laid inside special self-extinguishing conduit; all the aforesaid lines are connected with special spring-type terminal blocks, the latter positioned inside the engine room main electrical panel and in the various electrical sub-panels.
- The system is highly fragmented into sub-circuits and protected with magneto-thermal switches and fuses for each single load or homogeneous load groups in order to simplify the tracing of possible faults which, for any line, can only occur at the load and the electrical panel.

The electrical system of your yacht consists of three distinct sections separated from each other.

- Service network powered by a nominal voltage of 24 V DC supplied by 12 batteries of accumulators 2 V DC - 640 Ah each, connected in series with each other so as to constitute a bank of the total capacity of 640 Ah at the voltage of 24 V. The aforementioned bank of batteries is recharged by the output of the service charger and by the alternator pulled by the port-side propulsion engine of the yacht.
- Engine mains powered by a nominal voltage of 24 V DC supplied by four batteries of 12 V DC - 220 Ah accumulators each, connected in series

and parallel to each other so as to constitute a bank of the total capacity of 440 Ah at the voltage of 24 V. This bank of batteries is recharged by the engine charger as well as by the alternator driven by the starboard engine of the yacht. The engine charger automatically disconnects when the engines start.

- Utility network 120/240V powered by the platform network, or alternatively, by the two generating assemblies present on the yacht (main generator power 32 kW, secondary generator power 32 kW). Each generator assembly is powered by a 12 Vdc - 180 Ah battery located near the generator itself and recharged by an alternator driven by the unit itself.

The yachts are equipped with electronic injection machines and electronic remote control systems, for this reason it is very important for the user to carry out some simple operation to prevent faults to the electric systems, which on their turn may cause problems to the propulsion system.



CAUTION

Before undertaking any navigation, check that the batteries are in good condition and that they supply the correct nominal current.



CAUTION

During navigation both the button-switch of the user batteries and the button switch of the engine batteries must always be connected, that is positioned to ON. The parallel button switch on the two sets must be normally disconnected and therefore set to OFF.

**CAUTION**

If during navigation an operation fault on the re-charging alternators occurs, set to ON the button switch of the parallel connection between the batteries sets and let it connected until the fault has been removed.

**CAUTION**

Never start navigation without having set to ON both the engines batteries switch and the uses batteries switch and do not disconnect them during navigation.

**CAUTION**

If, during navigation, a remarkable and continuous voltage drop of one nor both battery banks occurs, check the recharging efficiency (alternator recharge on monitoring system) of the relevant alternator. If the alternator is not operating, it is necessary to start the power generator and to activate the independent electrical battery chargers.

**CAUTION**

The parallel system between battery banks is used to increase the inrush current during the start-up phase of engines, in particular weather conditions or state of charge, and for a limited period of time. This system must be activated only if the button switches connecting the engines and user battery banks are positioned to ON. Do not use in case of faults on the batteries recharging circuits, for instance on the engines alternators. We advise to use this system only in emergency cases.

**DANGER**

Do not modify the electric systems or relevant drawings. The installation, the modifications or the maintenance must be carried out only by a skilled naval electrician. Inspect the system at least once a year.

The protection of the single electric system sections is performed by automatic magneto-thermal switches of different amperage and size, according to the absorption of the various services to be protected and by the size of cables used for their supply.

All metallic wet pieces are interlocked with equipotential connections and linked on sacrificial anodes installed on the underwater quick-work.

**WARNING**

Refrain from performing any modification or intervention on the system and on the panel and take advantage of experienced Companies and skilled staff. Avoid particularly derivations on electric lines and splices of services not provided for on the same panel. Finally, if you need to assign services to the switches available, make sure that their characteristics are suitable with the device installed.

**CAUTION**

If you are compelled to use the “battery parallel connection”, turn off all electronic devices, so as not to jeopardize their correct operation. In emergency conditions, use the battery parallel set for the shortest reasonable time.

**CAUTION**

The engine control systems: accelerator and gears engagement remote controls are electronic. Their reliability is very high, but in case of a sudden black-out, it is necessary to immediately switch off the engine which is not controllable any more by means of the relevant buttons located in the main helm station.

**DANGER**

Before carrying out any intervention on the electric system, disconnect all circuits (shore, generators and inverter):

- Disconnect the shore sockets;
- Set to OFF the magneto-thermal switch of generators;
- Set to OFF the magneto-thermal switches at inverter output and turn off the inverter (off button on the front).

**CAUTION**

Do not modify the electric systems or relevant drawings. The installation, the modifications or the maintenance must be carried out only by a skilled naval electrician. Inspect the system at least once a year.

**WARNING**

To reduce shock and fire hazards to the minimum:

- Open the ground power connection switch of the unit before connecting or disconnecting the ground power cable;
- Connect the ground power source;
- Disconnect the shore power cable first from the power source (shore power column) and then from the unit.

**CAUTION**

Use electric devices with double isolation or grounding.

**DANGER**

We recommend, in order to operate in complete safety, to carefully read the safety rules relevant to the maintenance and contained in this manual.

**DANGER**

Before starting to work on electrical panels or devices, prevent the generators' operation by disconnecting the electric power supply from shore and the inverter.

**CAUTION**

Disconnect the shore power supply connections when the system is not in use.

**WARNING**

NEVER:

- Work on the electric system while under voltage.
- Modify the electric systems of the system or relevant drawings: the installation, the modifications and the maintenance must be carried out only by a skilled marine electrician.
- Alter or modify the intensity of rated current of protections against overcurrent.
- Install or replace electric equipment or devices with components exceeding the rated current intensity of the circuit.
- Leave the yacht unattended with the electrical system powered, except for the circuits of the bilge automatic suction pumps, of the fire-fighting protection and of the alarms (directed to battery).

**WARNING**

Do not allow the cable end of shore power supply to float in the water. This can cause an electric field and following injuries or even the death of the swimmers nearby.

**CAUTION**

Do not modify connectors of shore power supply cable, use only plug compatible connectors.

**DANGER**

The 120/240V system is similar to a domestic system in terms of features and risks and, if "wrongly" used, mishandled or serviced, it statistically represents one of the most frequent reasons for fire on board.

**DANGER**

Electrocution hazard! Turn the power off before removing the cover and servicing any electrical equipment internal component.

**DANGER**

All electrical systems (included those at low voltage) if wrongly handled or subjected to overloads, can originate short-circuits and dangerous overheating with potential fire hazards!

**WARNING**

Before carrying out any maintenance operations, disconnect all electrical power sources.

The on-board services are supplied by separate electric systems with different features:

- 24 V DC (Direct Current)
- 120/240V AC (Alternating Current) (60Hz)

**CAUTION**

RIVA suggest to examine very carefully the whole documentation delivered by the manufacturers of the various components; and for any problem relevant to maintenance, to contact RIVA After Sales & Service Department directly.

**WARNING**

Before stopping the power generator, disconnect the various on-board services supplied by this; stopping the power generator under load can irreparably damage the electronic control units of the various uses and have a negative influence on the generator operation.

However, please refer to the manual of the power generator to obtain more detailed information about the starting and stopping procedures.

AC-DC distribution system:

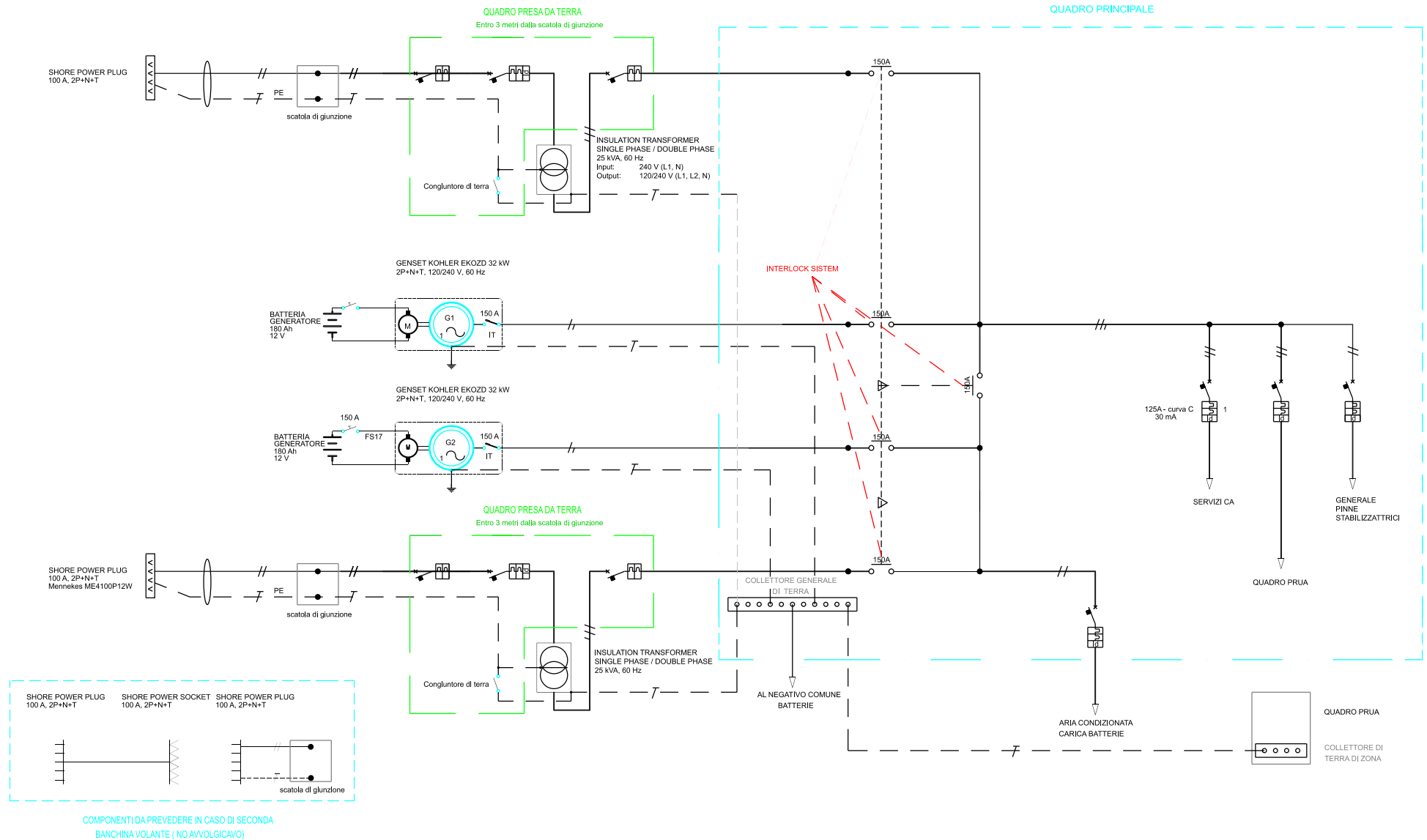

Hull electrics arrangement:

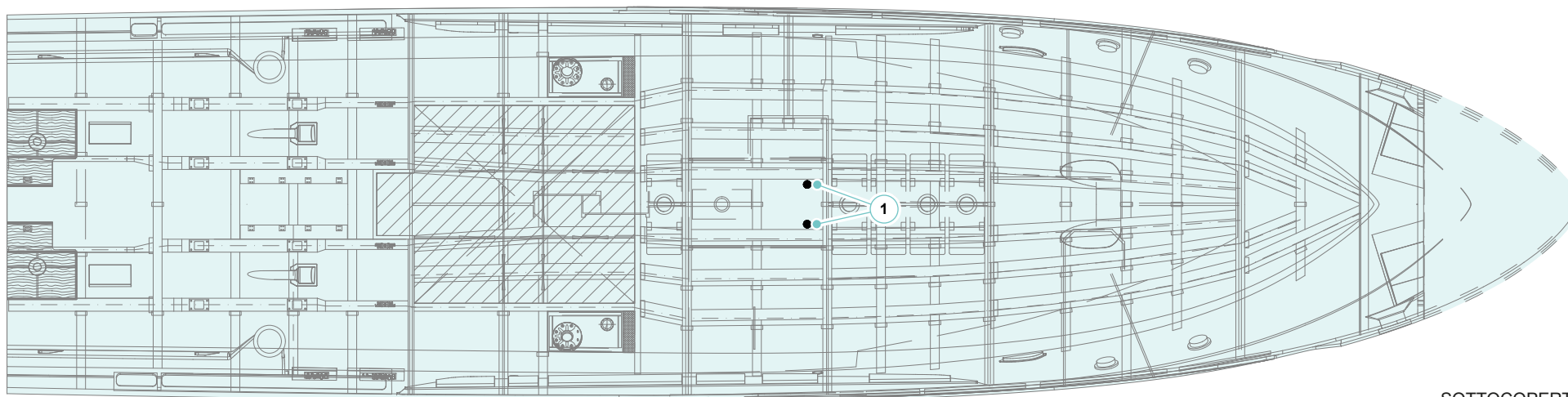

SOTTOCOPERTA
LOWER DECK

ICONA ICON	DESCRIZIONE DESCRIPTION
1	Piastra porosa Porous plate
2	Trasduttore Transducer
3	Anodo Anode

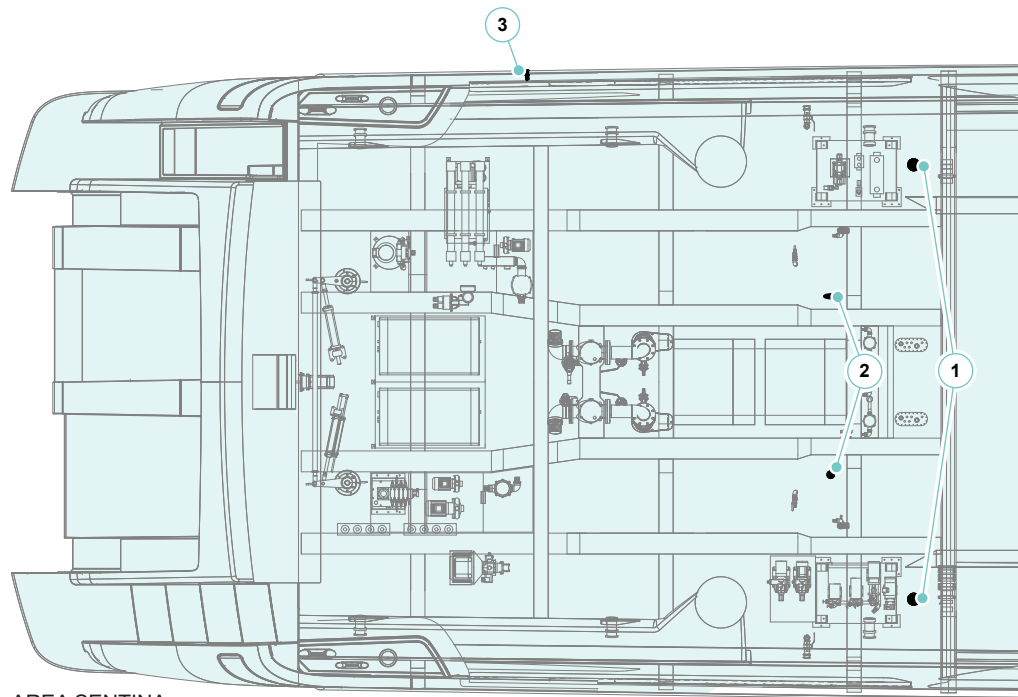

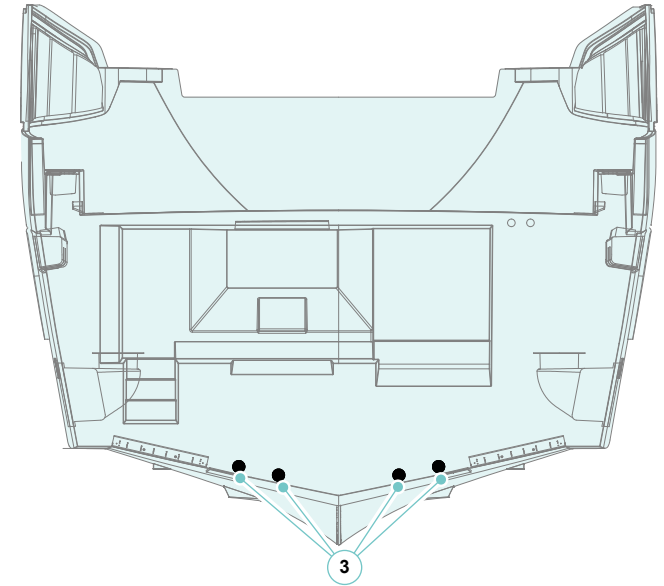

AREA SENTINA
BLIGE AREA



VISTA DA POPPA
STERN VIEW

ICONA ICON	DESCRIZIONE DESCRIPTION
1	Piastra porosa Porous plate
2	Trasduttore Transducer
3	Anodo Anode

7.1.1 Maintenance of the electric system

Component	Maintenance	Notes and precautions
Equipment and circuits	Cleaning and checks	<p>Have the condition of connections on electric boards, panels and boxes checked periodically by skilled and equipped staff. Make sure that ground connections of electric equipment and electrical panels are tight and not oxidized. Have the absorption of the different electric motors periodically checked by skilled personnel. When cleaning the bottom hull, carefully clean the electronic instrument ground static dischargers; moreover, check the condition of the protection anodes and if necessary, replace them. During the lay-up period, do not apply any antifouling on the ground static dischargers.</p> <div style="border: 1px solid black; padding: 5px; margin: 10px 0;"> <p style="text-align: center;">MAINTENANCE</p> <p>At least once a week check the operation of all electrical panels. At least once every six months:</p> <ul style="list-style-type: none"> • Check the possible presence of damaged cables; • Protect the various contacts. </div> <div style="border: 2px solid red; padding: 10px; margin: 10px 0; text-align: center;">  <p>DANGER</p> <p>Before starting to work on electrical panels or devices, prevent the operation of the generators by disconnecting the electric power supply from shore and the inverters.</p> </div> <div style="border: 2px solid red; padding: 10px; margin: 10px 0; text-align: center;">  <p>DANGER</p> <p>Do not modify the electric systems or relevant drawings. The installation, the modifications or the maintenance must be carried out only by a skilled naval electrician. Inspect the system at least once a year.</p> </div>

7.2 ELECTRICAL PANELS

7.2.1 Main electrical panel

The electrical system is monitored from the electrical panel located in the crew area, going through the access of the stern cockpit.

The following main sections have been identified, in order to make the descriptions easier:

- A. Uses command buttons 24V and measuring instruments voltage
- B. Magneto-thermals for protection of 24V uses.
- C. Uses command buttons and 120/240V electrical measuring instruments.
- D. Uses command buttons magneto-thermals for protection of 120/240V uses.



CAUTION

Before removing the front panel for maintenance, stop the power generators, disconnect the shore sockets and the inverter.

NOTE

For a detailed description refer to the electric installation manual.

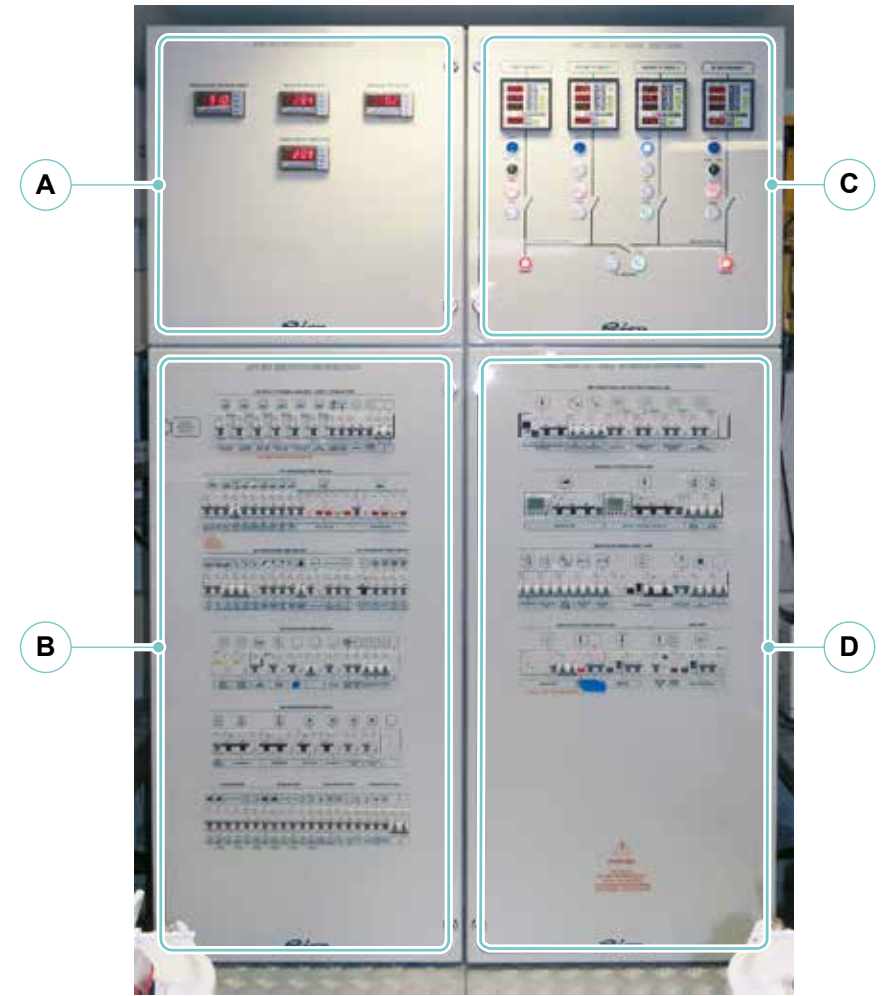

Uses command buttons 24V and measuring instruments voltage:

24V DC SECTION MEASUREMENTS

SERVICE BATTERY DISCHARGE CURRENT



SERVICE BATTERY VOLTAGE



ENGINES BATTERY VOLTAGE



ENGINES ROOM AIR TEMPERATURE



Magneto-thermals for protection of 24V uses:

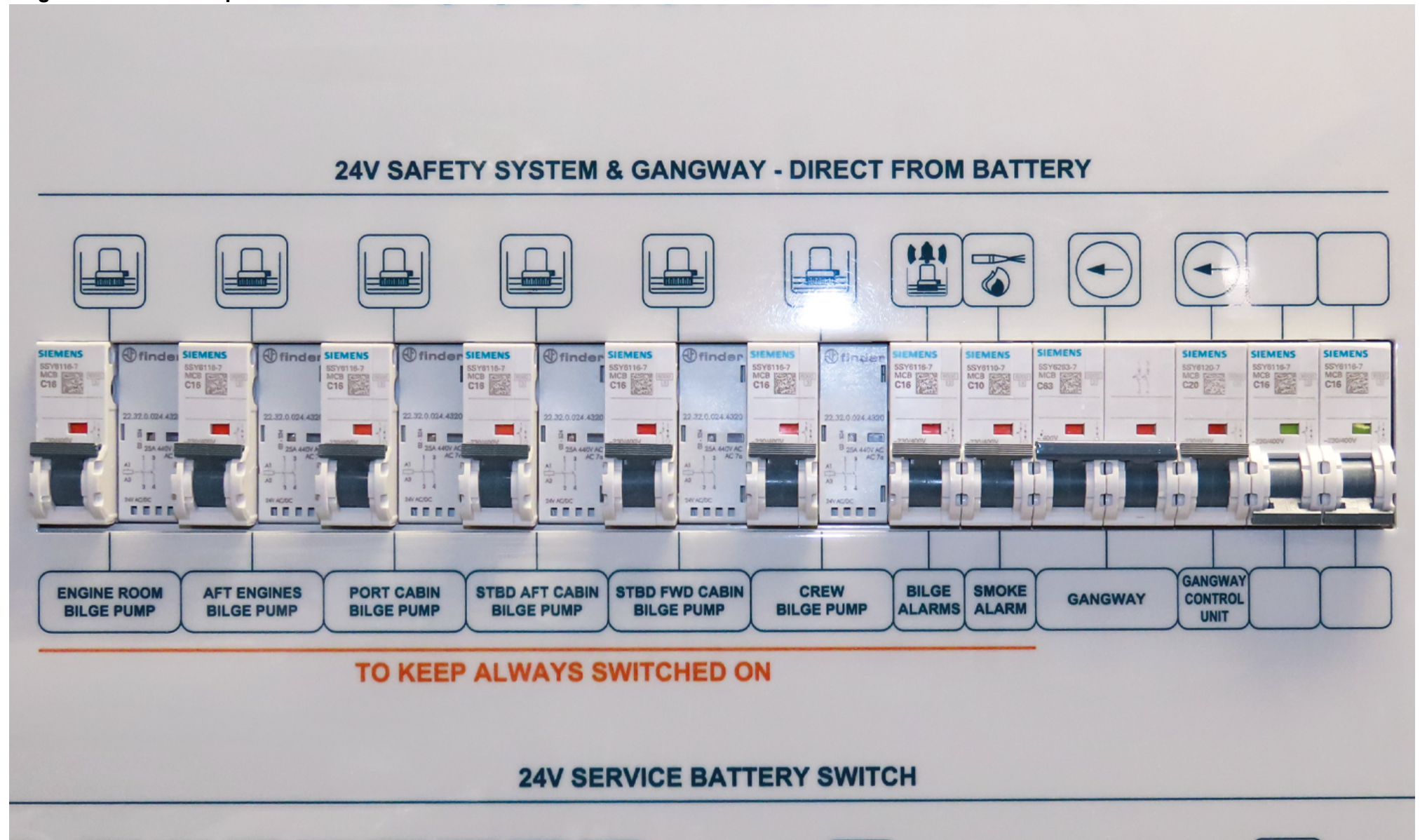

ENGINE ROOM BILGE PUMP AFT ENGINES BILGE PUMP PORT CABIN BILGE PUMP STBD AFT CABIN BILGE PUMP STBD FWD CABIN BILGE PUMP CREW BILGE PUMP BILGE ALARMS SMOKE ALARM GANGWAY GANGWAY CONTROL UNIT

TO KEEP ALWAYS SWITCHED ON

24V SERVICE BATTERY SWITCH

Icons above breakers: Bilge pumps, Fresh water pump, Port stern grey transf. p., Stbd stern grey transf. p., Port fwd grey transf. p., Stbd fwd grey transf. p., Crew grey transf. p., Crew water cond. p., Grey water pump, Black water pump.

Labels below breakers: AFT PLATFORM GARAGE HATCH, MULTIP. BILGE PUMP, FRESH WATER PUMP, PORT STERN GREY TRANSF. P., STBD STERN GREY TRANSF. P., PORT FWD GREY TRANSF. P., STBD FWD GREY TRANSF. P., CREW GREY TRANSF. P., CREW WATER COND. P., GREY WATER PUMP, BLACK WATER PUMP.

WARNING
KEEP AFT HATCH
BREAKER SWITCHED
OFF UNDERWAY

24V SERVICE BATTERY SWITCH

24V ENGINES BATTERY SWITCH

Icons: Bilge pumps, Fresh water pump, Port stern grey transf. p., Stbd stern grey transf. p., Port fwd grey transf. p., Stbd fwd grey transf. p., Crew grey transf. p., Crew water cond. p., Grey water pump, Black water pump, Bilge pumps, Fresh water pump, Port stern grey transf. p., Stbd stern grey transf. p., Port fwd grey transf. p., Stbd fwd grey transf. p., Crew grey transf. p., Crew water cond. p., Grey water pump, Black water pump, Bilge pumps, Fresh water pump, Port stern grey transf. p., Stbd stern grey transf. p., Port fwd grey transf. p., Stbd fwd grey transf. p., Crew grey transf. p., Crew water cond. p., Grey water pump, Black water pump, Bilge pumps, Fresh water pump, Port stern grey transf. p., Stbd stern grey transf. p., Port fwd grey transf. p., Stbd fwd grey transf. p., Crew grey transf. p., Crew water cond. p., Grey water pump, Black water pump.

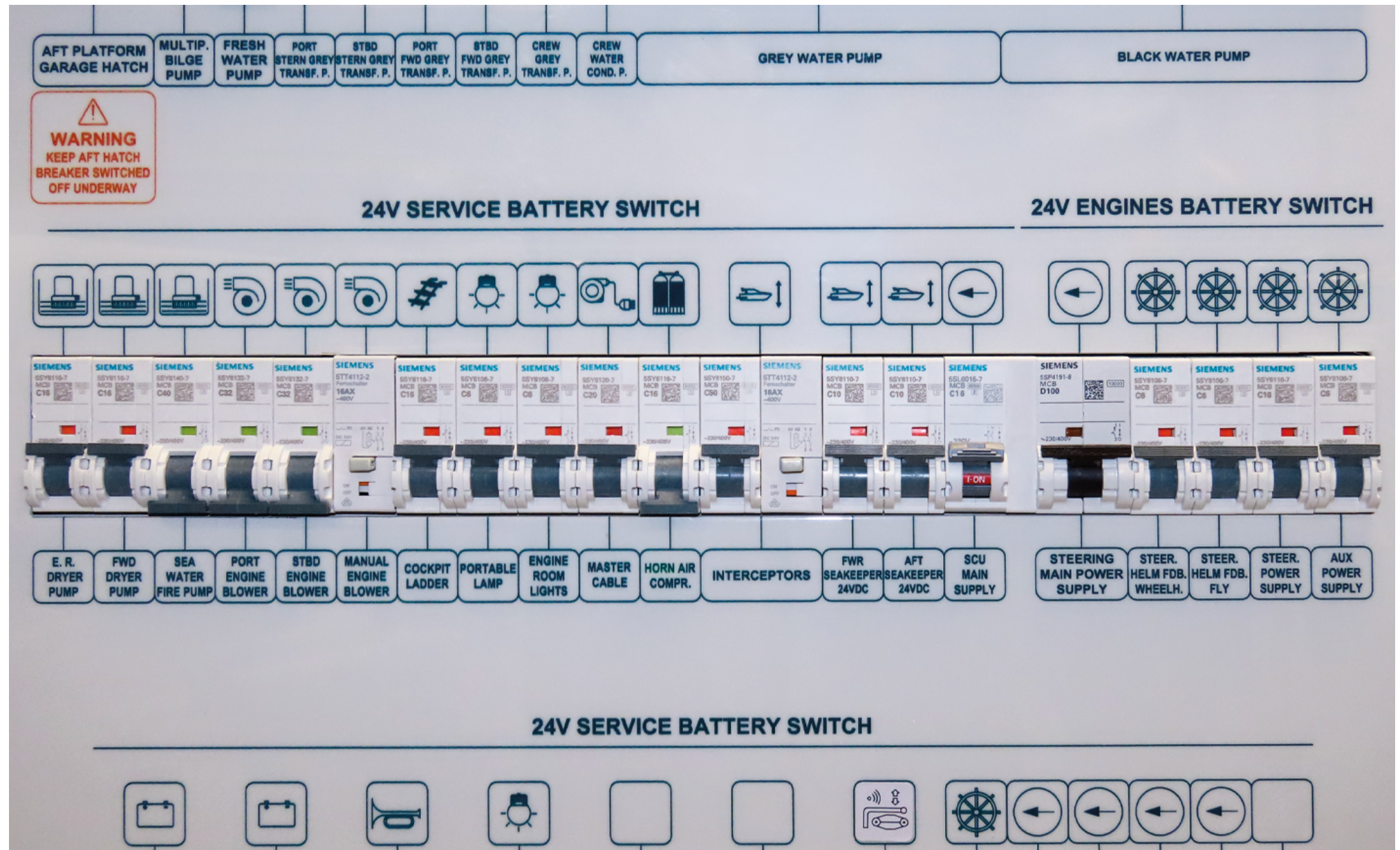

ER PUMP FWD DRYER PUMP SEA WATER FIRE PUMP PORT ENGINE BLOWER STBD ENGINE BLOWER MANUAL ENGINE BLOWER COCKPIT LADDER PORTABLE LAMP ENGINE ROOM LIGHTS MASTER CABLE HORN AIR COMPR. INTERCEPTORS FWR SEAKEEPER 24VDC AFT SEAKEEPER 24VDC SC MAIN SUPPLY STEERING MAIN POWER SUPPLY STEER. HELM FDB. WHEELH. STEER. HELM FDB. FLY STEER. POWER SUPPLY PO SU

24V SERVICE BATTERY SWITCH

QU13 QU14

GENSET 1 BATTERY CHARGER GENSET 2 BATTERY CHARGER HORN COMMAND GARAGE LIGHTS GARAGE LIFT SENSOR SEC. STEER. POWER SUPPLY STEERING COOLING PUMP CONDENS. CHILLER SEAKEEPER PUMP 1 SEAKEEPER PUMP 2

24V ENGINES BATTERY SWITCH



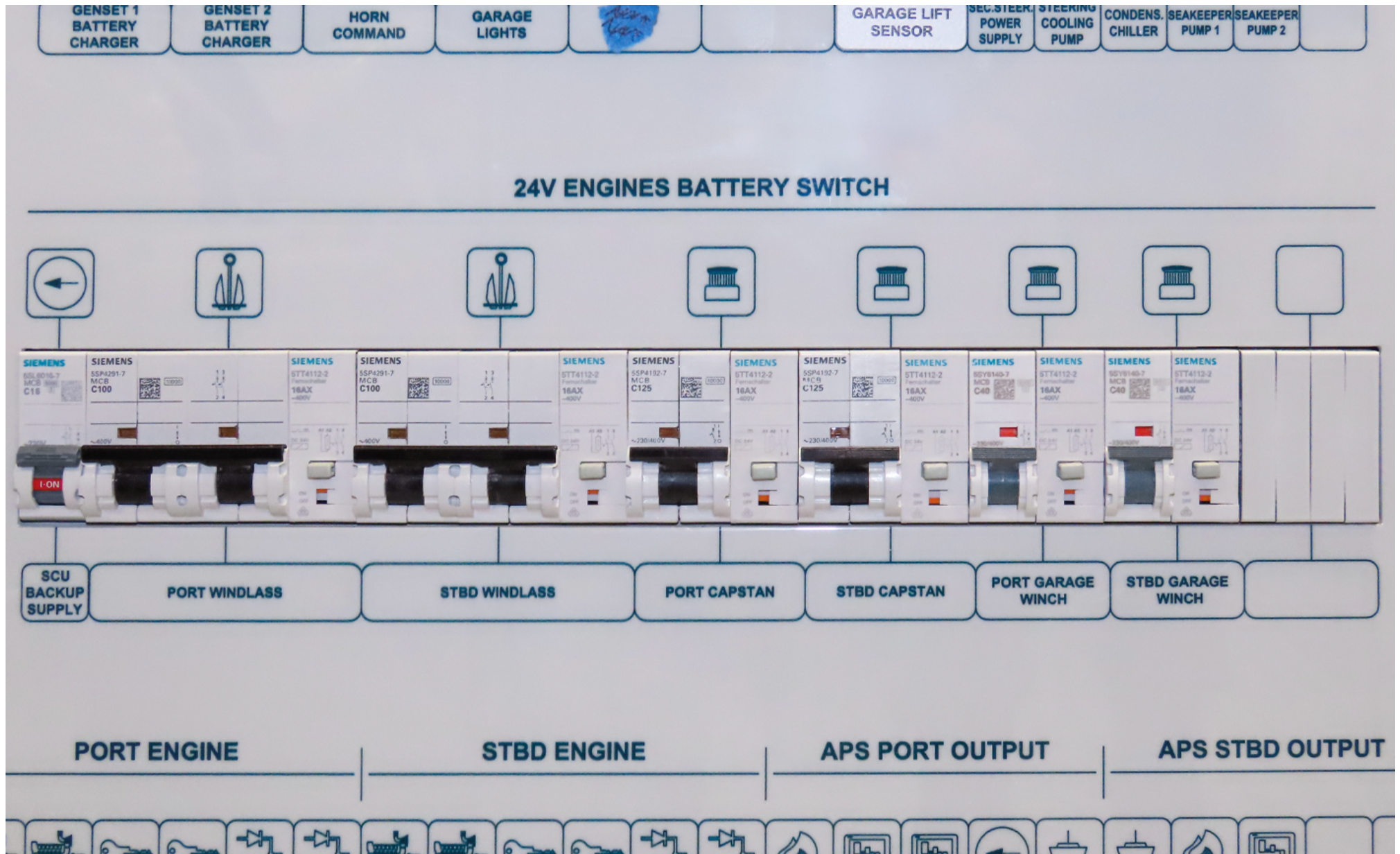

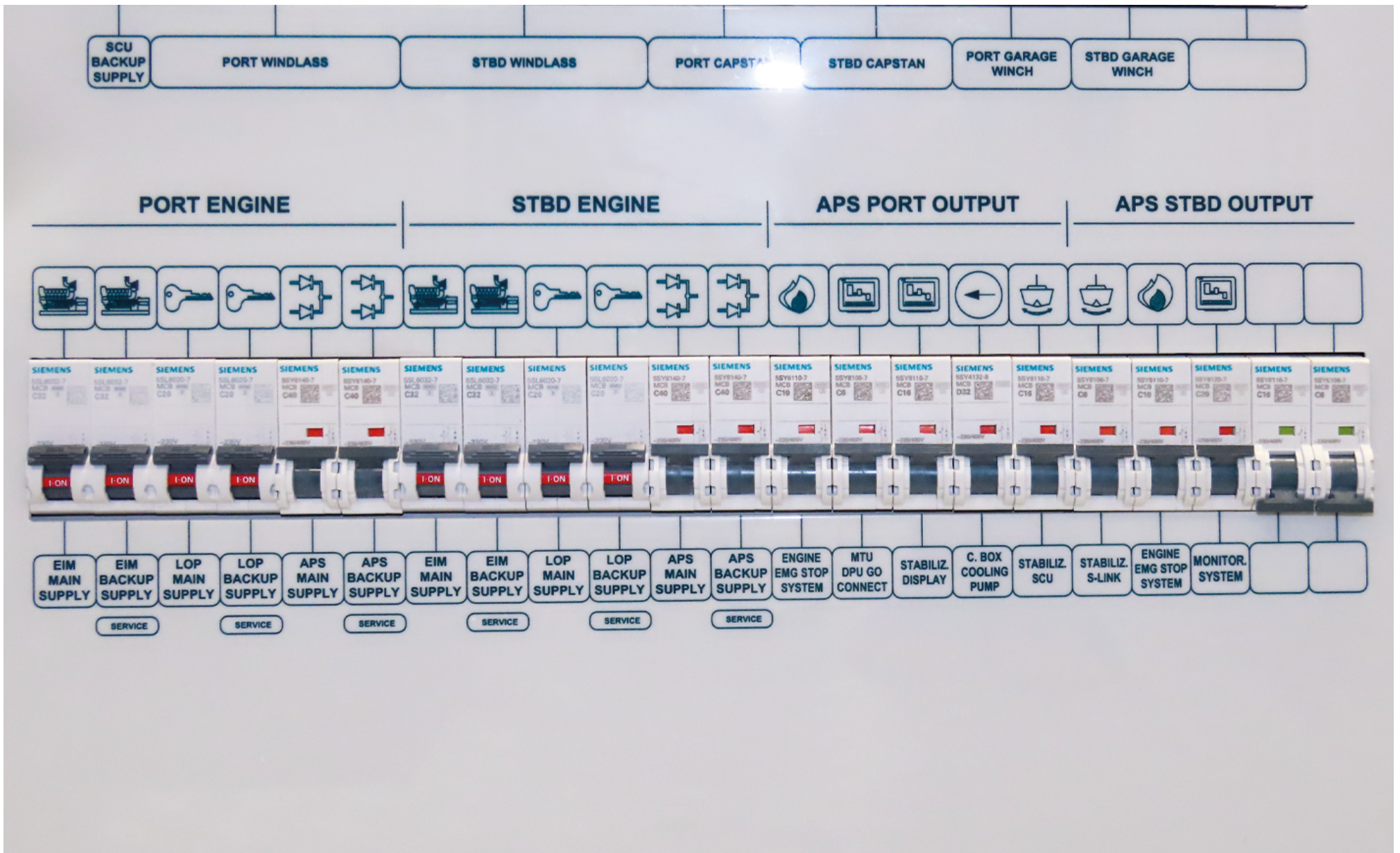

Uses command buttons and 120/240V electrical measuring instruments:

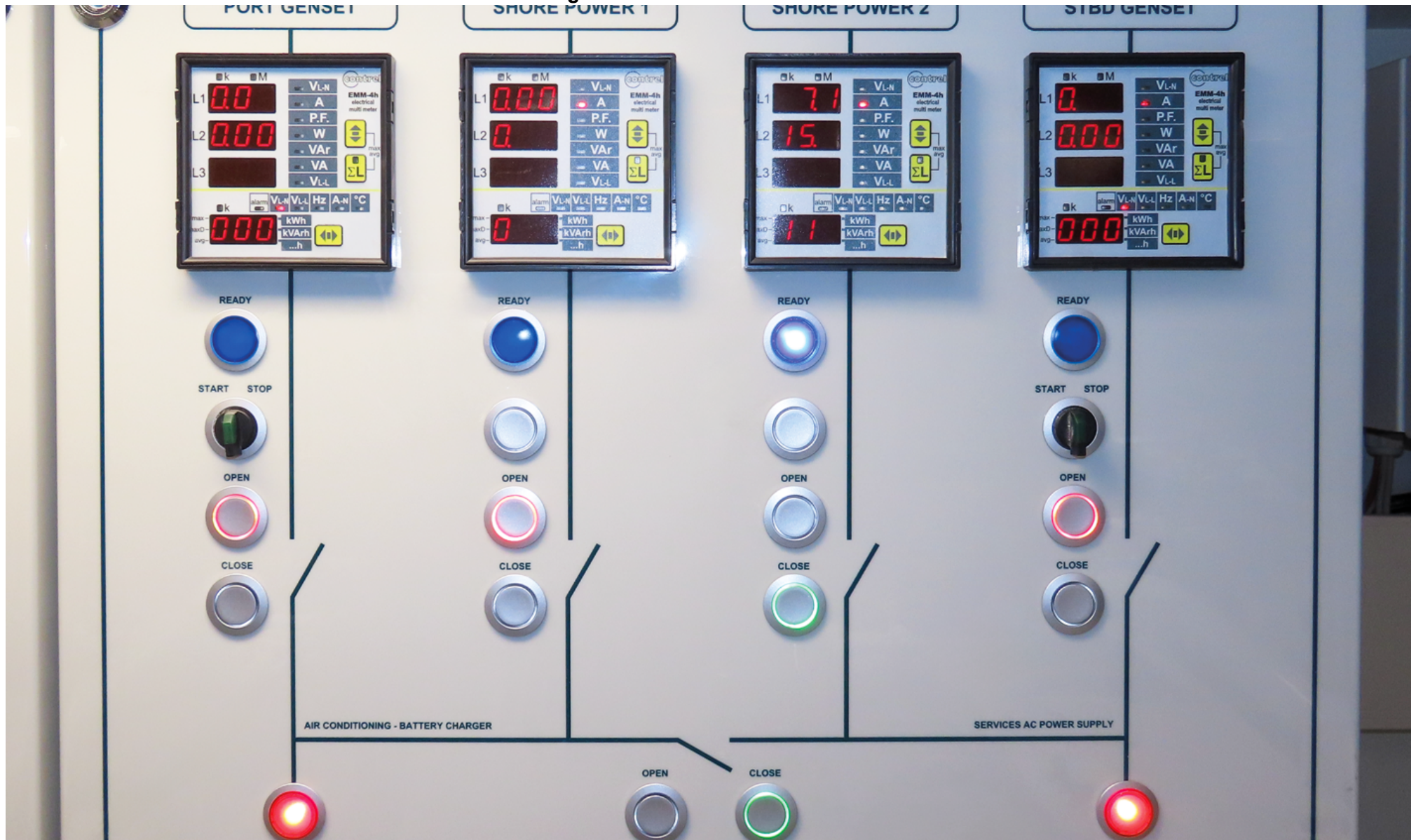

Uses command buttons magneto-thermals for protection of 120/240V uses:

120 / 240V AC - 60Hz BUSBAR DISTRIBUTION

AIR CONDITIONING AND BATTERY CHARGER LINE



SERVICES AC POWER SUPPLY LINE





SERVICES AC POWER SUPPLY LINE



SERVICES AC POWER SUPPLY LINE



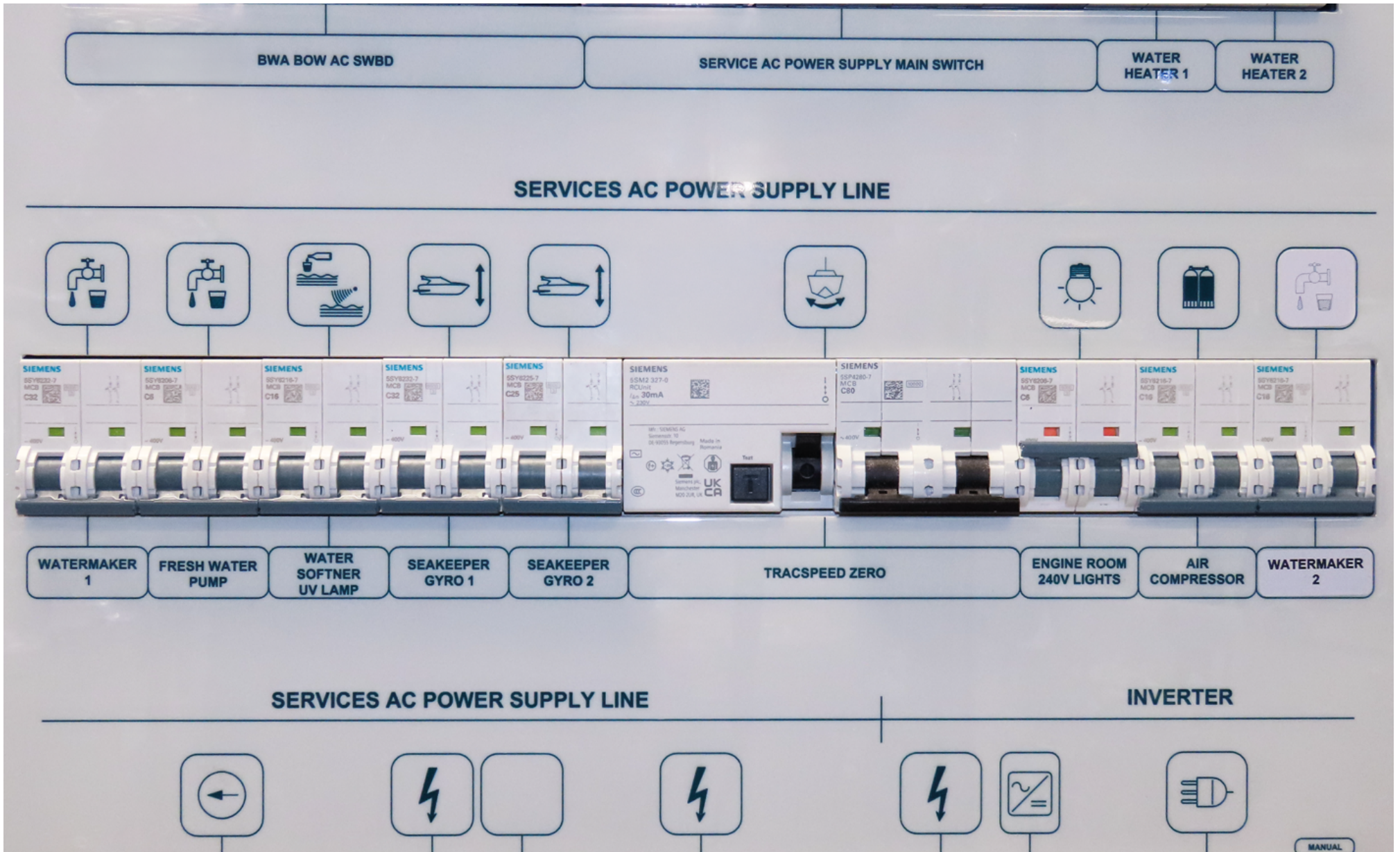

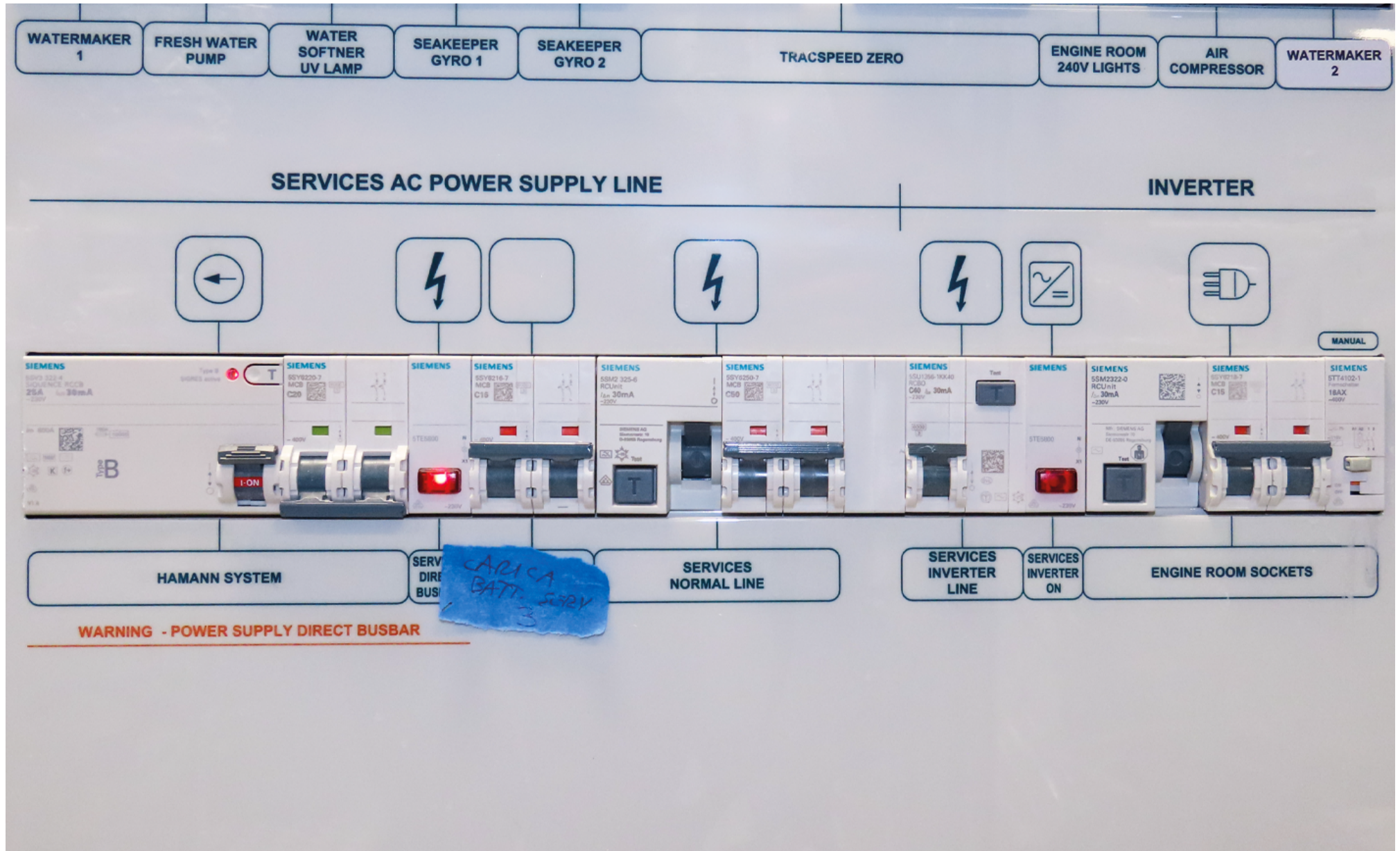

7.2.2 Synoptic panel in the main helm station

The synoptic panel is located in the main helm station. For an easier description of the panel, the following main sections have been identified:

- A. Buttons and lights suction system control bilge and grey and black water system.
- B. Buttons and lights control and street navigation lights and anchor winch control buttons.



CAUTION

The test switch is used to verify the correct operation of the light test circuit, by means of warning lights installed on the synoptic panel. By means of the test button, all LEDs must be lit, indicating the correct operation of the light system. The fuses protect the navigation lights.

DURING NAVIGATION (navigation light switch to ON)

If the warning light is red, the navigation light does not operate and must be replaced; if the warning light is green, the navigation light operates correctly. The lighting up of the red led confirms that the bulb is burnt, or that the protection fuse has tripped.

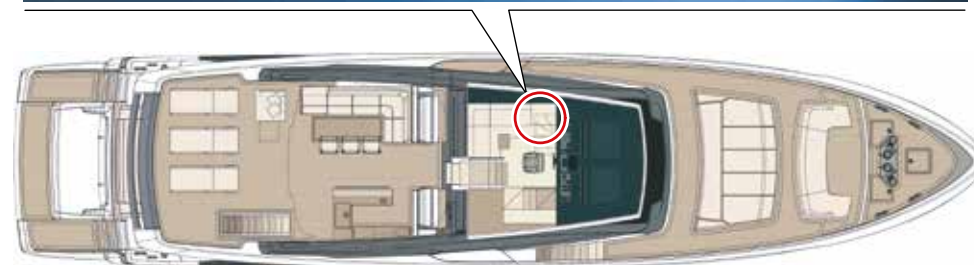
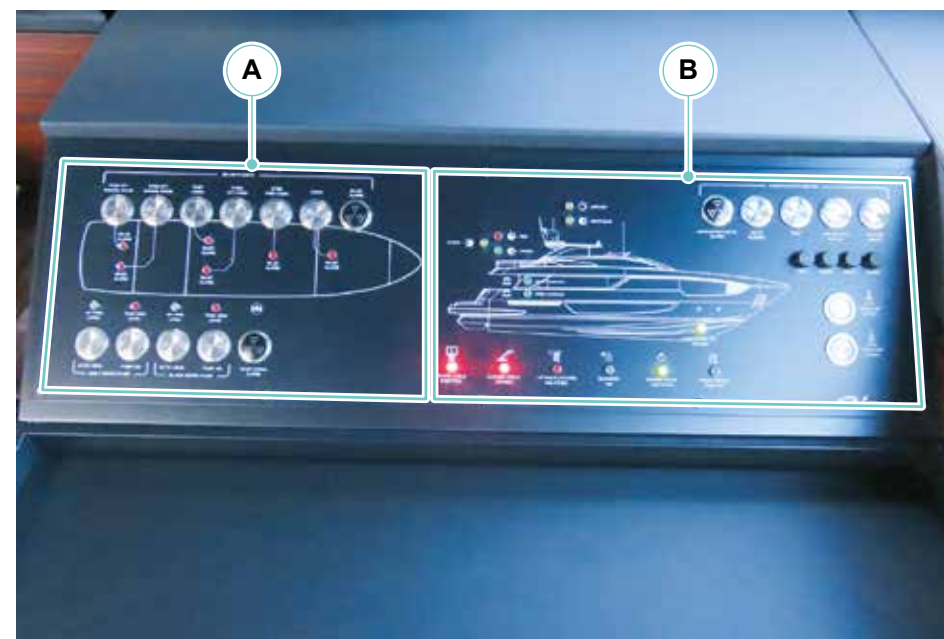

7.2.3 120/240V bow electrical panel

At the bow of the salon there is an electrical panel equipped with various magneto-thermals to protect the various loads present in the galley. For a better comprehensive description of the electrical panel the following main sections have been identified:

- A. Magneto-thermals to protect galley appliances.
- B Magneto-thermals to protect services and fridge.



CAUTION

Before removing the front panel for maintenance, stop the power generators, disconnect the shore sockets and the inverters.

NOTE

For a detailed description refer to the electric installation manual.

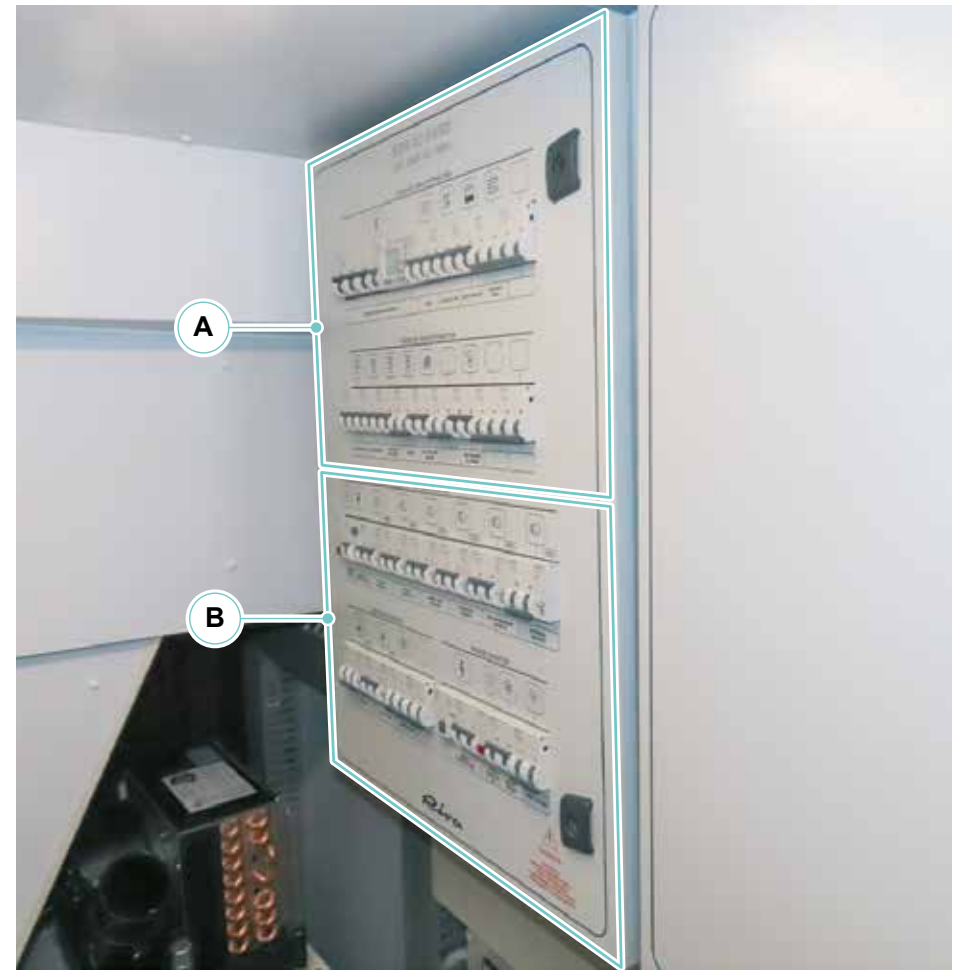

Magneto-thermals to protect galley appliances:

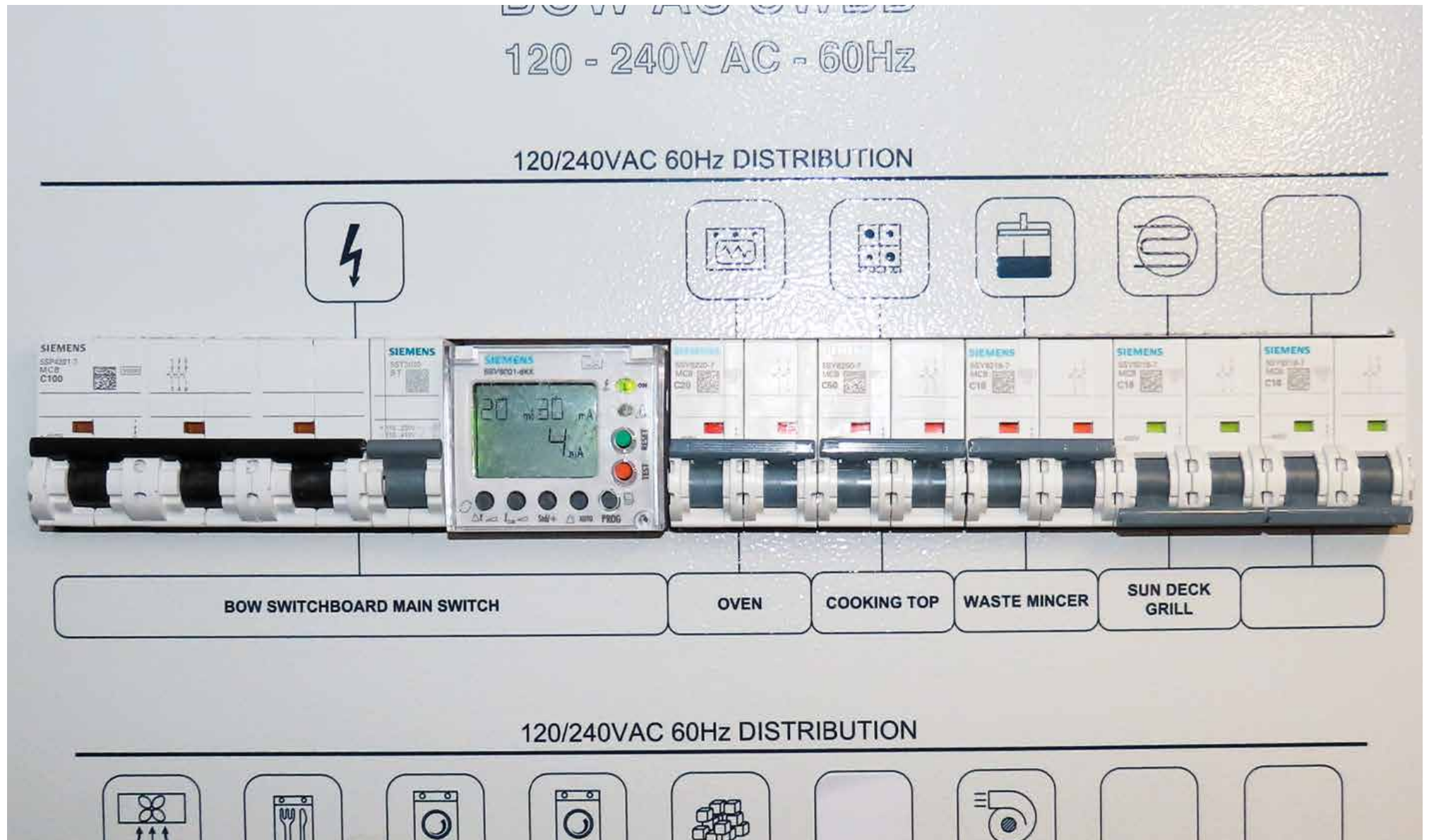

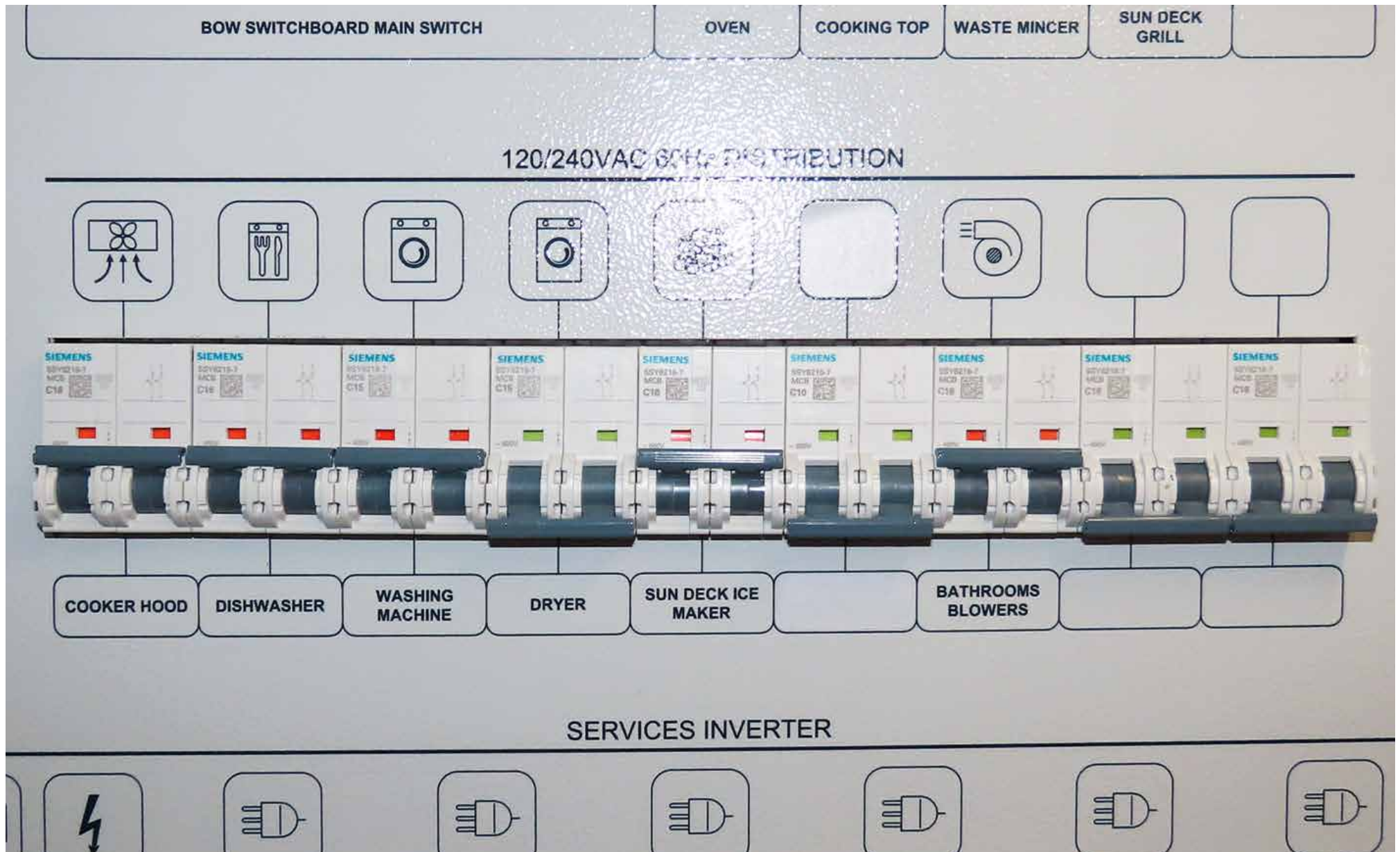

Magneto-thermals to protect services and fridge:

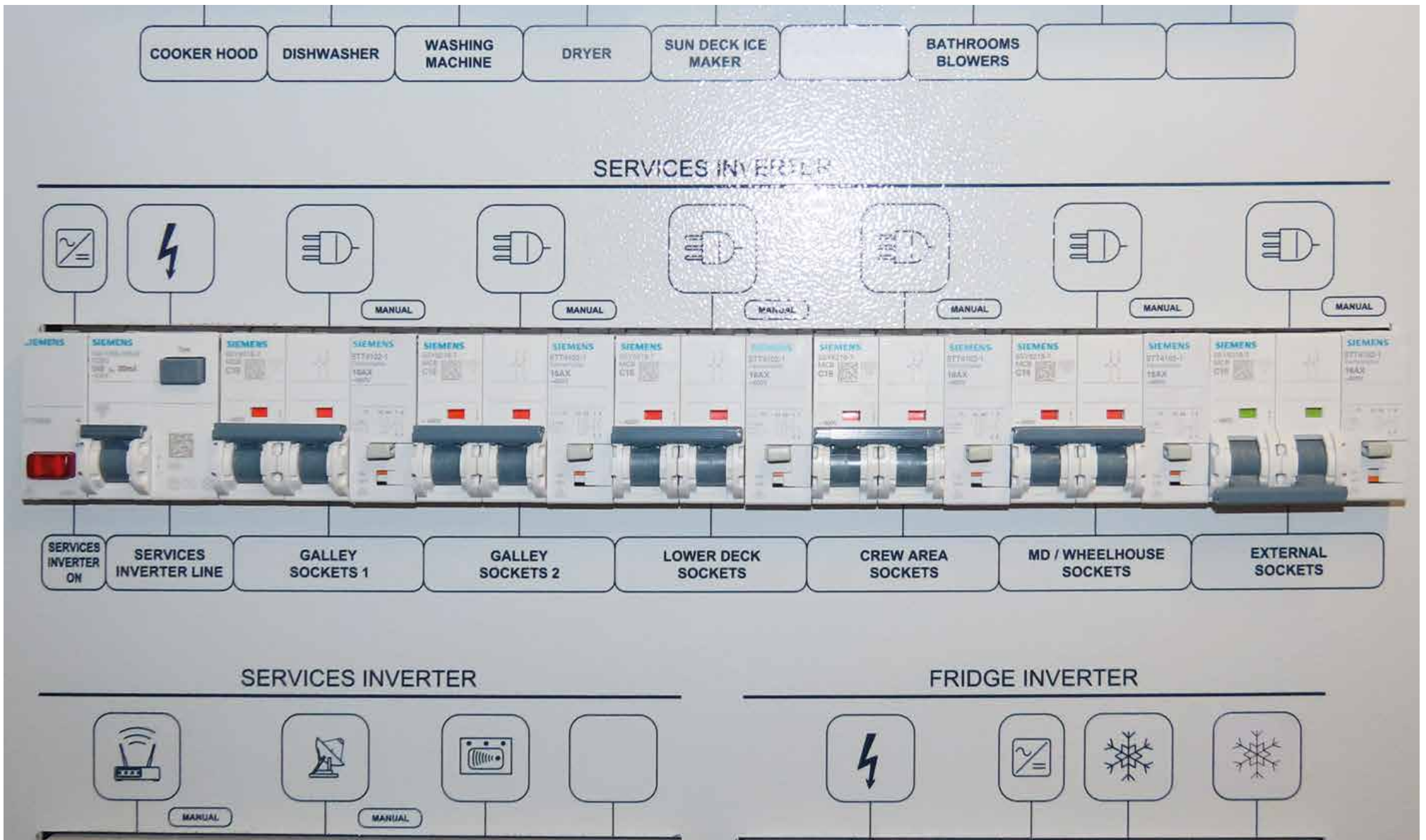

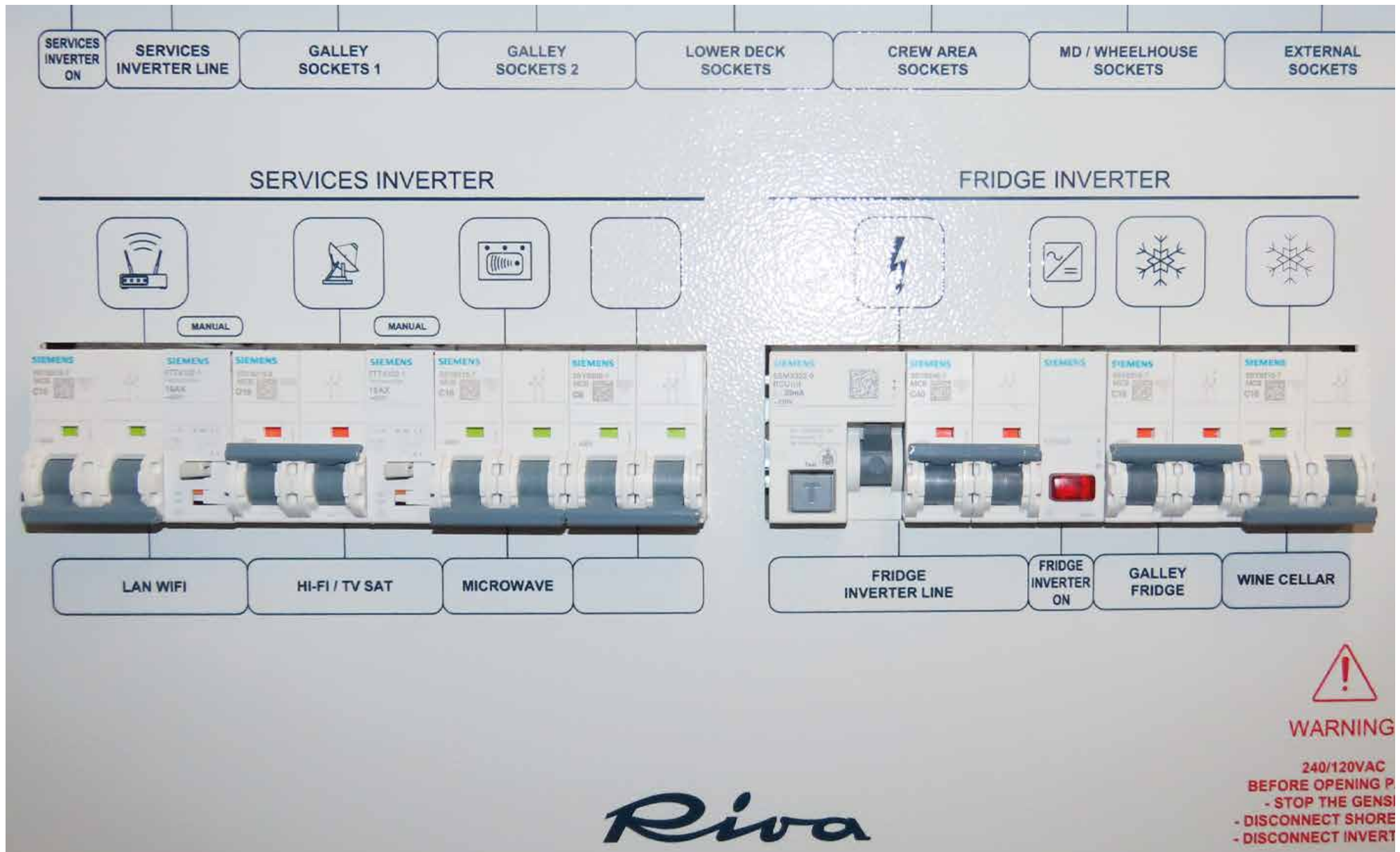

7.2.4 24V bow electrical panel

At the bow of the lounge there is an electrical panel equipped with various magneto-thermals to protect the various uses present in the various cabins of the yacht.

To make the description of the electrical panel more comprehensible, the following main sections have been identified:

- A. Magneto-thermals to protect wheelhouse uses.
- B. Magneto-thermals to protect lights and on-board uses.



CAUTION

Before removing the front panel for maintenance, stop the power generators, disconnect the shore sockets and the inverters.

NOTE

For a detailed description refer to the electric installation manual.



Magneto-thermals to protect wheelhouse uses:

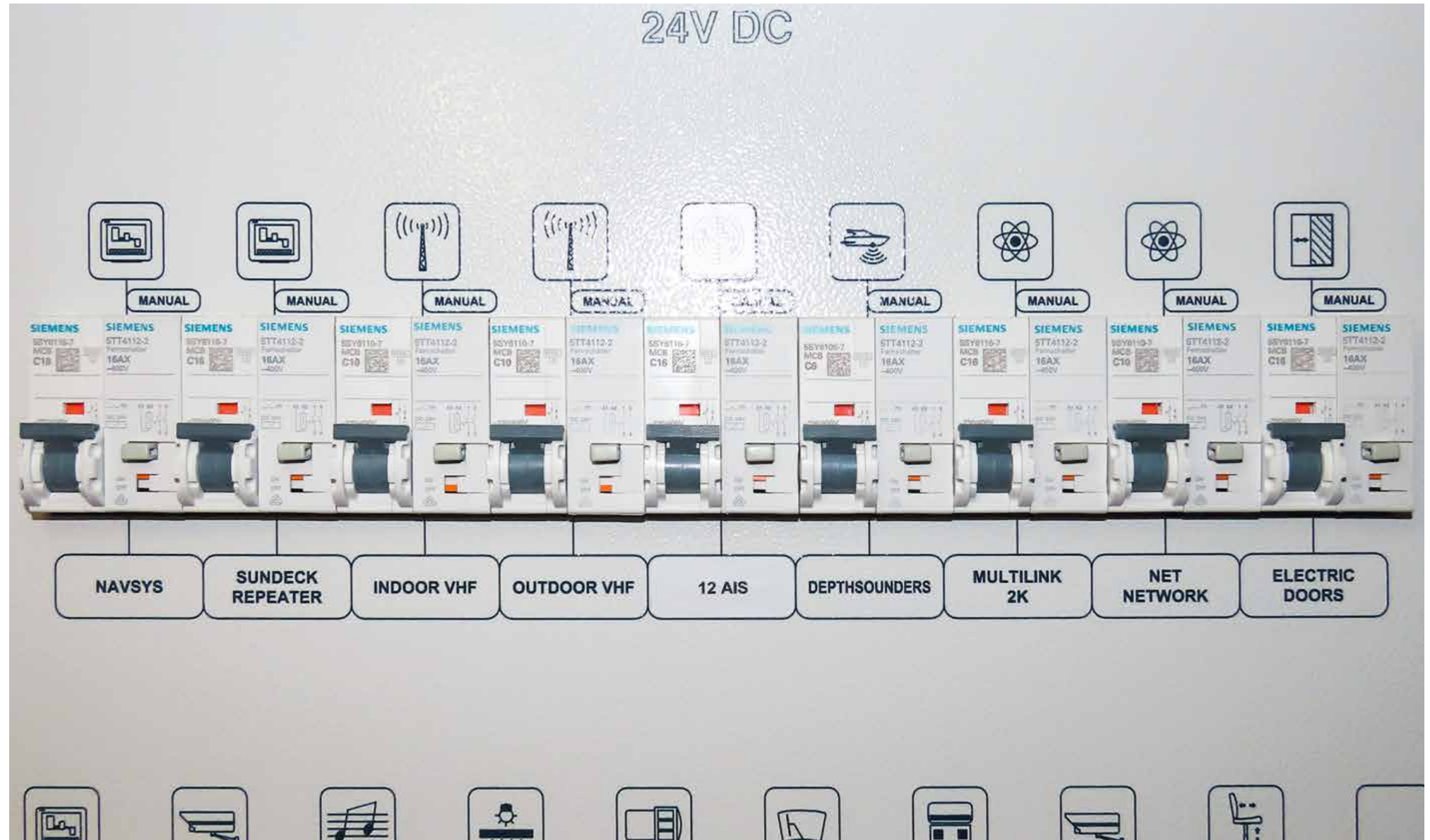

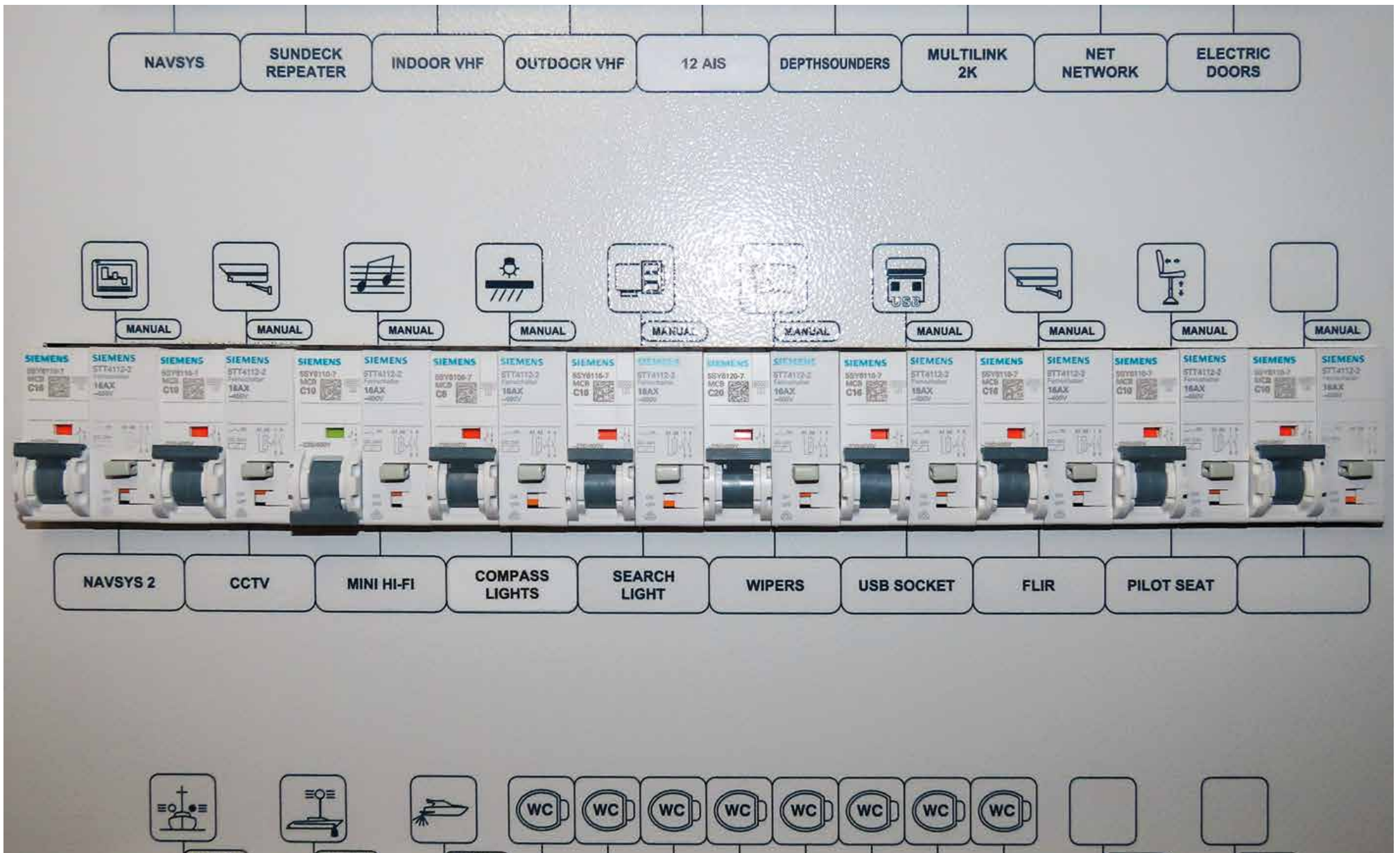

Magneto-thermals to protect lights and on-board uses:

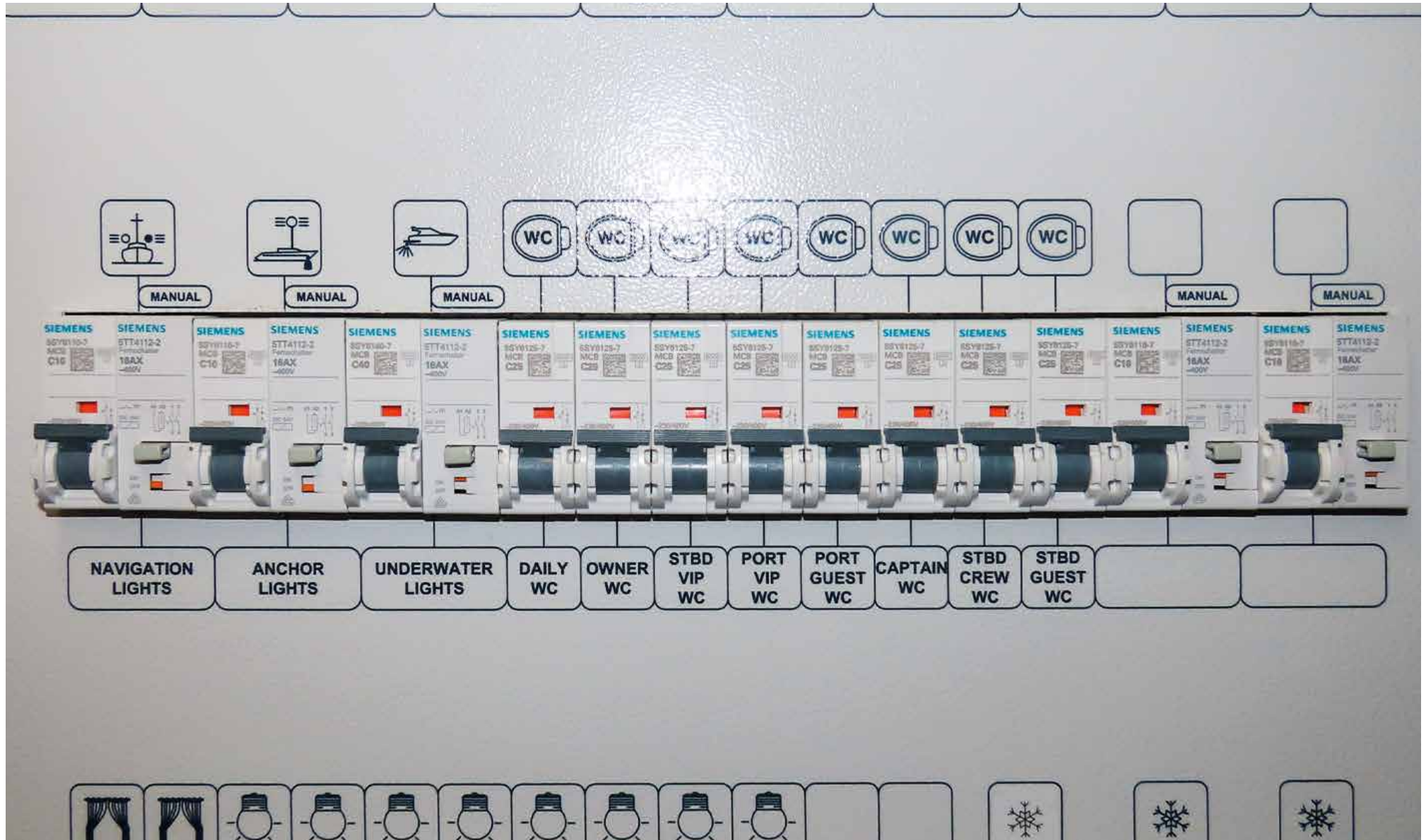

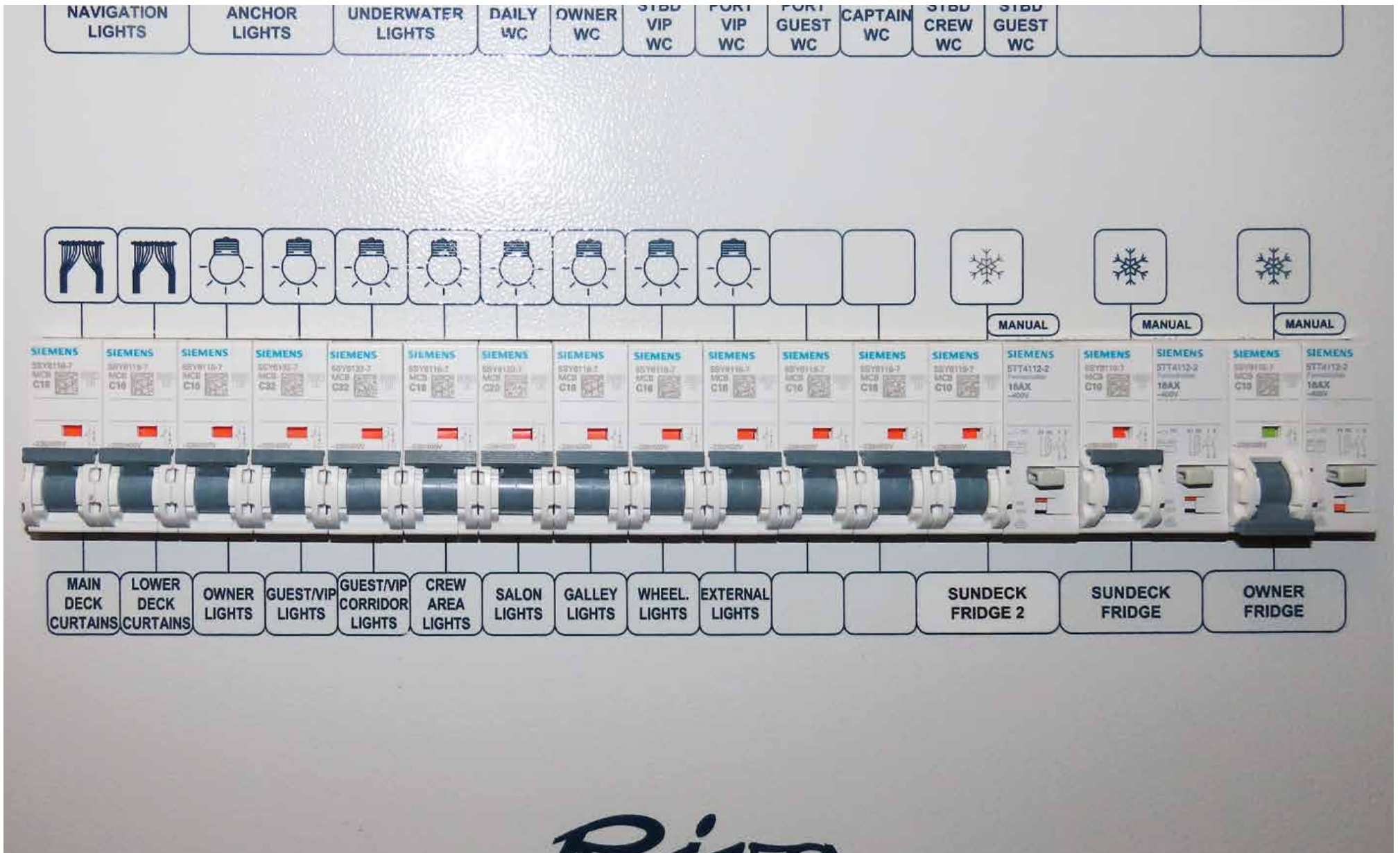

7.3 GROUND PROTECTION

On board there is an adequate grounding dispersion system fitted with a porous plate which constitutes the “means” of grounding the generator PE conductor, to which all the grounds of the alternating current systems are connected as well as all the negatives of the direct current systems.



DANGER

If the yacht is out of the water, position the ground bar near the platform panel in the DRY DOCK position.



DANGER

If the yacht is out of the water and connected to the shore power supply, check the presence of the shore system in the power supply system.



WARNING

Periodically check the status of sacrificial anodes and porous plate: replace if the reduction for corrosion is more than 50% of their original mass. If their wearing is particularly quick, the on board electric system could be leaking. Have the electric system checked by experienced personnel.



Grounding system:

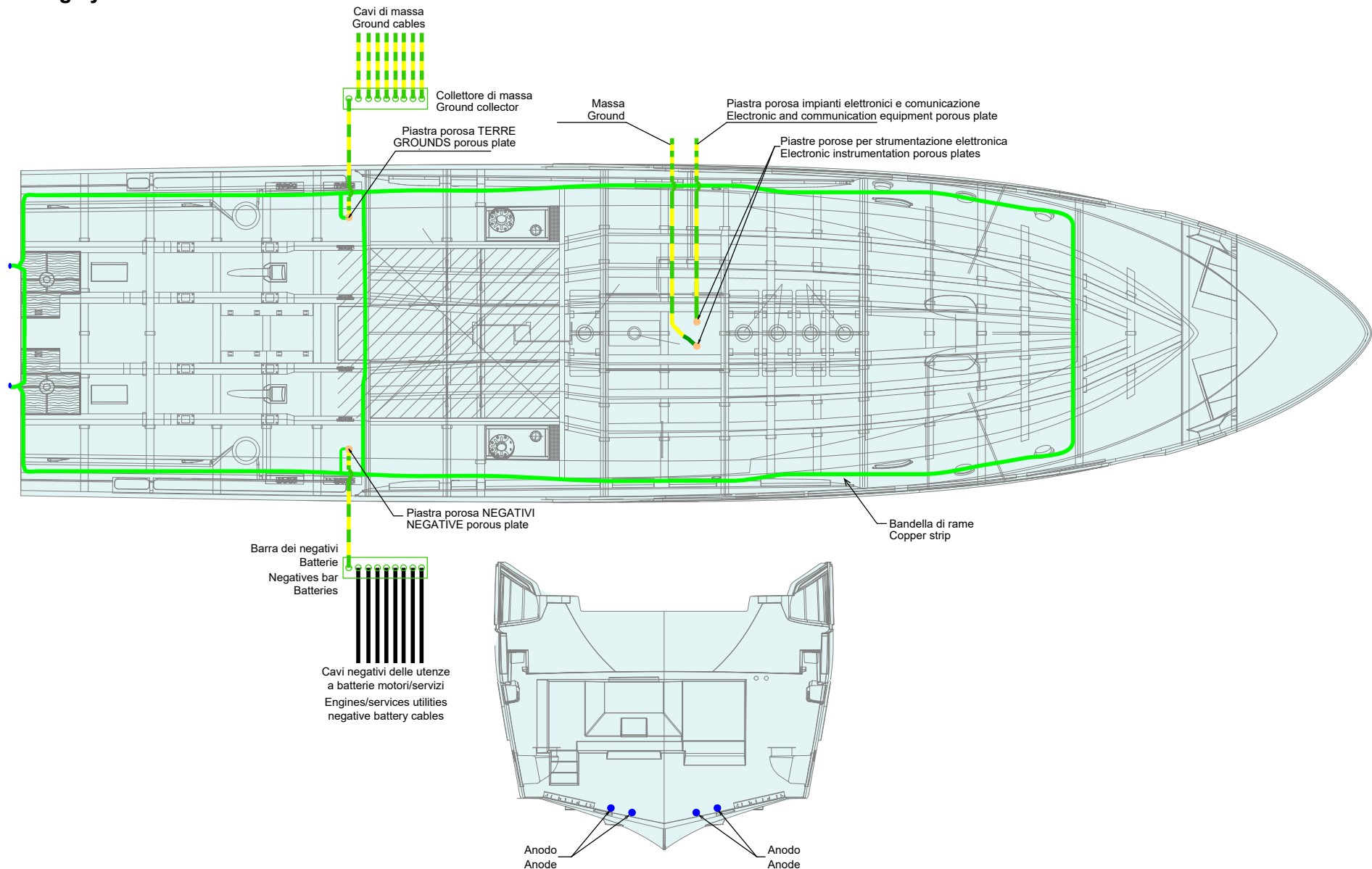

7.4 FUSES

In addition to these protections, there are common fuses with types and characteristics appropriate to the specific installation.

Please refer to the electric system user's manual for their location on board.

The main fuses on board have the following characteristics:

- 25 A
- 80 A
- 100 A
- 160 A
- 200 A
- 250 A
- 315 A



DANGER

For reasons of safety and reliability of any electrical system, any fuse must be replaced with one which has the same electrical characteristics: in case of doubt, consult an expert technician.



DANGER

At the end of eventual replacement of a fuse, ensure the proper keeping: DO NOT not leave any foreign objects inside the panel.

NOTE

For more information, refer to the Equipment Manuals provided on board.

7.5 BATTERY SET

The batteries are normally charged by the alternators during the operation of the engines. As an alternative, you can recharge them with the battery charger from shore or with the generator.

Description	Element number	Features element
Engine start	4	12 V 220 Ah
Generator start	1 + 1	12 V 120 Ah
Services batteries	12	2 V 640 Ah



WARNING

The batteries left unloaded over long periods of not operation, lose progressively their charge, until they become completely flat and get irreparably damaged.



DANGER

NEVER obstruct the air intakes of the battery boxes as natural ventilation must always be allowed so that the batteries do not overheat.



WARNING

While the engines are running, it is advised to set the battery charger thermic to OFF to avoid damaging the alternators.



WARNING

Do not lay objects on the cases containing the batteries.



CAUTION

A frozen battery may blow up if used or charged; do not start a yacht with frozen battery. To prevent the battery from freezing keep it always completely charged.



DANGER

The battery releases explosive gas: do not approach flames, sparkles or smoke near it. If the battery is used or charged in a closed area, ensure ventilation.

Do not check the battery charge by short-circuiting the terminals with metal tools: use a densimeter or a voltmeter.



WARNING

EXPLOSION HAZARD

Any lithium battery powered device on board must be recharged only in open air areas, connected to a suitable charging system. Also please refer to the device dedicated Use and Maintenance Manual.

7.5.1 Maintenance of the batteries

Component	Maintenance	Notes and precautions
Batteries	Battery check (accumulators)	During the periods when the yacht is not in use, have the battery terminals disconnected, or leave them all connected and have periodically all batteries charged (generator included).



CAUTION

In case of contact with the batteries electrolyte wash contaminated part with fresh water for at least 15 minutes and ask for a doctor.



CAUTION

Remove bracelets, rings and every other piece of jewellery before working on the batteries.



WARNING

All the maintenance listed must be carried out by specialised personnel.



CAUTION

Always keep the batteries charged and recharge them periodically even if the yacht is left unattended.
If the charge level drops to the minimum, the batteries can get irreparably damaged.



CAUTION

Monitor the voltage of the engine and user batteries.
During the charging phase 29.1V can be reached, this is a temporary value, well tolerated, both by the batteries and by the battery charger.
This value has to be monitored and if this situation lasts for too long, the magneto-thermal switches of the battery chargers must be disconnected.



CAUTION

Check the condition of batteries for the presence of galvanic corrosion on connection poles and terminals; if some is noticed, address to the Service Department and have the pieces showing this kind of problem replaced.

Carry out following checks:

Terminal inspection

- Check that the battery containers are clean and dry and that the terminals are coated with silicon grease and properly fastened. Clean and grease as required.
- Identify positive and negative cables, prior to connecting (connect the positive terminal first and then the negative, in order to avoid sparkles).



DANGER

Batteries may be subject to explosion hazard, with subsequent risks of serious personal injuries. Do not use open flames, smoke, cause sparks or use arc-welders in the area where batteries are located. Do not disconnect battery cables when the generator is running.

Battery acid may cause serious injuries. Wear safety goggles, gloves and protective clothing.

Do not wear any bracelet, ring or any other jewel when operating on batteries.

In case of contact with battery acid, wash the contaminated part with fresh water for at least 15 minutes and address to a doctor.



DANGER

Always remove the negative terminal (-) for grounding connection first and connect it last.

7.6 BATTERY BREAKER PANEL

The battery switch panel (1) is positioned at the entrance of the engine room, accessible from the stern cockpit on the port side.

The panel includes the electrical remote control switches (each with green LEDs) that insert:

2. Services batteries;
3. Parallel connection between engine and services batteries;
4. Engine batteries.

When the LED are ON the batteries are operating, in order to disconnect them press again the buttons (LED OFF).

The battery parallel connection can temporarily be connected also from the main helm station dashboard by means of proper switch.

If the electric battery breaker controls do not operate, you can use the manual battery breaker control buttons, located in the engine room.



CAUTION

Do not disconnect the battery breaker switches with the engines running because the engine alternators might get damaged.



CAUTION

Use the "Services-Engine parallel connection" breaker only if strictly necessary and disconnect it as soon as possible.

**CAUTION**

The switch parallel services/engines must be used only if the engine batteries are not charged enough.

The switch parallel batteries must be operated only with the switches in banks link button batteries services and engines ON.

**DANGER**

Keep the breaker of the battery-powered uses set to ON. Cut out only in case of maintenance.

1. Batteries breaker

This switch allows cutting in or out the user battery set.

2. Services/engine battery parallel connection breaker

If the engine batteries are flat or not sufficiently charged, the battery main switch allows the parallel connection between user battery bank and the engine battery bank, to enable the start of the propulsion engines.

**CAUTION**

This connection must be activated only if the engine batteries are not sufficiently charged. The battery parallel connection switch, must be activated only with buttons connecting the user battery banks and the engine banks set to ON.

3. Engine batteries breaker

This switch allows cutting in or out the engine battery set.

4. Generator batteries breaker

These allow cutting in or out the generator batteries.

5. General battery breaker for battery-powered uses**6. Battery switch box**

Contains the devices battery master services, engines and parallel services/engines.

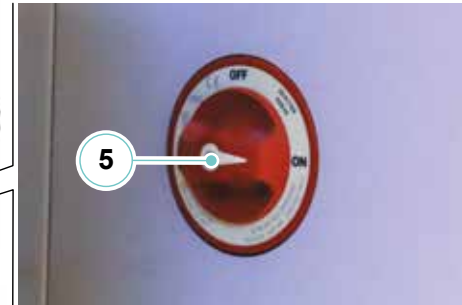
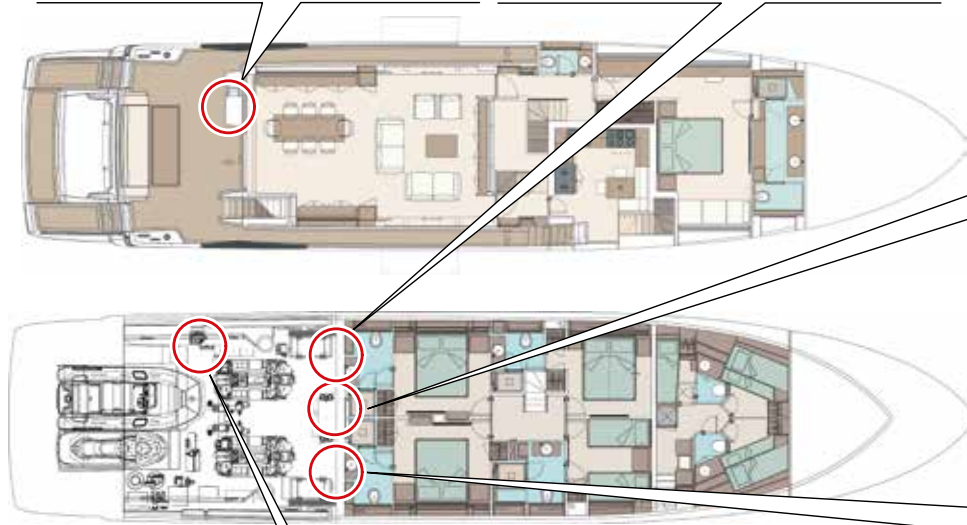
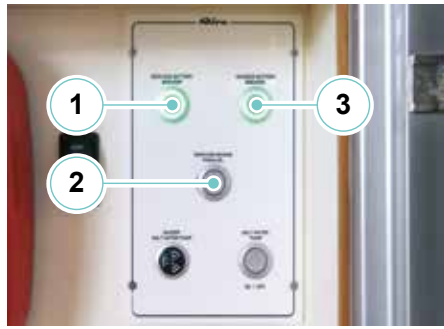

7.7 SHORE ELECTRIC POWER SUPPLY



DANGER

Before connecting the shore socket, ensure the type of voltage and the sockets available, their integrity and the absolute absence of moisture on the wire, on the socket and on the plug.

With plug connected check that wire:

- Cannot get in traction as a result of tide variations, yacht movements, etc..
- Does not get crushed, etc..
- Does not dive into water.



CAUTION

The connection must be performed under safety conditions with not powered connections and by paying attention to carry out a correct grounding.

The shore columns can supply different types of voltage, according to the harbour where you are moored; contact the Port Authority for the correct power supply of the column you are going to be connected.

In order to power the yacht's electrical system, which in turn ensures operation of the various onboard systems, two 100 A 60 Hz shore connection have been fitted astern.

By means of the control panel it is possible to check and to monitor the electric parameters, this facilitates the prevention of possible faults and malfunctioning and increases the safety of navigation.

It occurs very often to find shore plugs with dimensions not compatible with those on the yacht; in this case it is necessary to contact the Port Authority and to get a new plug or an adapter.

Electric shore power supply connection procedure:

- On the main engine room electrical panel, open (OFF) the general magneto-thermal switches of the on-board services;
- Open the shore socket power supply protection switch on the shore socket electrical panel (1);
- On the shore power column, open the power switch;
- Connect the power cable, first to the yacht and then to the shore column;
- Turn OFF the switch on the shore column;
- Close the power switch to protect the power supply to the yacht's shore socket;
- From the electrical panel in the engine room, select the shore power supply and monitor the voltage using the relevant instrument;
- Only if the voltage level is correct, close the magneto-thermal switches that feed the loads.

A supply voltage level controller is installed on the main electrical panel (upstream and/or downstream of the isolation transformer).

If the shore supply voltage is outside the correct operating range, the controller prevents selection of the shore supply and sends a signal to the monitoring station.

The controller is powered at 24V by the service batteries. If the batteries are flat or the controller is damaged, a by-pass control on the shore connection panel overrides the controller disable and enables manual selection of the shore connection.



CAUTION

Do not modify connectors of shore power supply cable, use only plug compatible connectors.
 If the yacht power supply cable cannot be plugged into the shore socket, ask the Port Authority for an adapter.
 In any case, never use adapters cutting the mass conductor connection between the shore electrical system and the yacht electric system.
 The use of these adapters can irreparably damage the electric devices.



DANGER

Do not leave shore power supply connected without people on board.



DANGER

Before carrying out any intervention on the electric system, disconnect all circuits and the shore plug.

NOTE

The transformer (2) is ventilated, periodically check that there are no obstructions on the grates and that the ventilation system is working correctly.



WARNING

If the warning lights on the main electrical panel in the engine room are ON, this means that the electric socket for shore power supply is plugged.



**CAUTION**

Disconnect the shore power supply connections when the system is not in use.

**DANGER**

Risk of electric shock from leakage currents.
Never swim in waters near harbours or marinas.

**WARNING**

Do not allow that cable end of shore power supply to floats in the water. This can cause an electric field as well as injuries or even the death of the swimmers nearby.

**CAUTION**

To cut the electric power supply from shore:

- Disable the shore power supply on the main switchboard in the engine room.
- Turn the shore connection switch on the engine room electrical panel to the OFF position.
- Turn OFF the protections on the shore column.
- First disconnect the power supply cable from the shore power supply source (shore column), then from the yacht.

MAINTENANCE

At least once every two weeks, have the various connections of electric boards, panels and boxes checked by experienced and equipped personnel. Make sure that ground connections of electric equipment and electrical panels are tight and not oxidized.

At least once a month check the status of the shore socket and eventually clean it.

7.8 BATTERY CHARGER

SERVICES BATTERY CHARGER:

On board of your yacht there are two fully automatic battery charger and high efficiency. They feature an optimized charge technique to charge batteries quickly and safely, while feeding the connected uses. In addition, they are protected against short circuits, overload and high temperatures (engine room).

On the front side of the chargers, a capacity gauge gives you some information on the residual capacity of the batteries, like the fuel level gauge of a car. More LEDs are ON, more the battery is charged.

Energisation

The battery charger is energized when the switch (8) is in the ON position. One of the LEDs on the front side turns ON and the charge starts immediately.

De-energisation

The battery charger is de-energised when the switch (8) is set to OFF. The connection between the electric mains and the battery charger is not interrupted with the switch.

Bulk (LED 1 ON)

The battery is discharged only when the first LED Bulk/ON (Quick charge/ON) is ON. Now the battery charger provides full power and the battery voltage increases slowly. After having reached the 27.6V level, the battery is about 25% charged and the second LED turns ON.

(LEDs 1 and 2 ON)

The battery has been charged to 25%. The battery charger still provides the maximum output current and voltage increases up to the level of absorption voltage. Phase A can last up to 6 hours max.

Absorption (LEDs 1, 2 and 3 ON)

The battery has been charged to 50%. The battery charger limits the charging voltage to a safe level and the charging current decreases slowly.

(LEDs 1 to 4 ON)

The battery has been charged to 75%. The charging voltage is limited to the absorption level, because the battery is nearly full. Current consumption will continue decreasing.

Maintenance (LEDs 1 to 5 ON)

When all the LEDs are ON, the battery is fully charged.

The slow maintenance/charging programme provides a output voltage, high enough to keep the batteries with a 100% charge, but low enough to prevent that the batteries suffer unnecessary constraints. The battery charger can now deliver full power to the connected uses/loads.



CAUTION

The connection between the electrical mains and the battery charger is not interrupted with the commutator.

LEDs ON	Meaning
Normal operation: the green light of LED no. 6 turns ON	
1	Battery charger ON
1+2	U output > 27.6V
1+2+3	U output = absorption (28.5V)
1+2+3+4	3 hours after the max. bulk time has started or I < re- turn amp
1+2+3+4+5	6 hours after the max. bulk time has started or I < re- turn amp. for 15 min or more
9	Recharging current equal to 0-5% of total current
9+10	Recharging current equal to 5-25% of total current
9+10+11	Recharging current equal to 25-50% of total current
9+10+11+12	Recharging current equal to 50-75% of total current
9+10+11+12+13	Recharging current equal to 75-100% of total current
6	Green: normal operation, red: faulty, OFF: stand-by or OFF
7	Green: communication of MasterBus in progress, OFF: no communication of MasterBus
Failure condition: the red light of LED no. 6 turns ON	
6 red +1	Battery detection error
6 red +2	Too high temperature of the battery charger
6 red +3	Short-circuit warning: the battery charger will reduce charging current to 25%
6 red +4	CC error: CC voltage is too low or too high
6 red +5	Temperature detection error

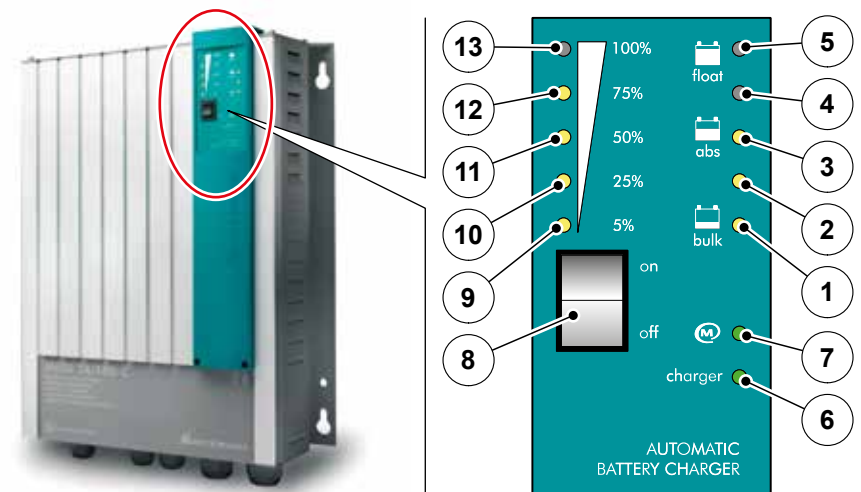

NOTE

For further information on use and maintenance, please refer to the manufacturer's manual.

ENGINE BATTERY CHARGER:

Your yacht is equipped with an onboard engine battery charger.

The ChargeMaster is a fully automatic battery charger.

This means that under normal conditions it can remain switched on with AC power and batteries connected. It has an automatic input device that allows operation with virtually any available AC power source. The three-step charging method ensures that the batteries are always 100% charged.

With an external AC source connected, the charger also functions as an AC/DC converter to supply DC loads connected to the batteries.

The battery charger can be activated by keeping the POWER switch pressed for about 3 seconds.

The POWER switch will start blinking green and the charging status will be displayed. If necessary and if AC power is provided, the battery charger will start charging the batteries.

In the event that the charger is in standby or the AC power supply is interrupted, the POWER switch starts flashing red. After about two minutes, it stops flashing and the display turns off, thus preventing the battery from charging by the indicator light.

NOTE

For further information on use and maintenance, please refer to the manufacturer's manual.

GENERATOR BATTERY CHARGERS:



Your yacht is equipped with two onboard generator battery chargers.

NOTE

For further information on use and maintenance, please refer to the manufacturer's manual.

7.8.1 Battery charger maintenance

Component	Maintenance	Notes and precautions
Battery charger	Check charge output	At least two or three times a year, have a specialist check the connection of each cable checked for looseness or oxidation. Keep the battery charger dry, clean and away from dust in order to ensure a good dissipation of heat. Periodically check the good condition of the cooling fan.



DANGER

Do not work on the battery charger or on the electric system if they are still connected to a current supply. Disconnect the mains supply before connecting or disconnecting the battery.
Modification to the electric system must be carried out exclusively by skilled personnel and only after the approval of RIVA.



DANGER

Have the inner condition of the battery charger checked by skilled staff at least once a year.
Faults like loose connections, burnt wires, etc., with following risk of fire spreading, must be repaired immediately.

MAINTENANCE

At least once a month check the correct operation of the battery charger.
At least once a month carry out the complete cleaning.
At least once every six months protect the contacts with proper products.



WARNING

If the engines are ON, the alternators are charging the batteries; it is therefore advisable to keep the magneto-thermal switch of the battery charger to OFF, in order to avoid alternator damage.



DANGER

EXPLOSIVE GASES - AVOID FLAMES OR SPARKLES

Position the battery in a well ventilated area.



DANGER

Before operating on the battery charger, disable the generators start and cut-OFF the shore power supply.

This device can operate in a reliable and optimal way, only if following operations are performed:

- Check that all breakers and indicator lights are working, the wiring does not present any signs of cuts and all parts are clean and free from oxidation;
- Remove the chassis and check the electronic boards for oxidation. Clean with deoxidiser if necessary;
- Protect the electric contacts by using an appropriate product (DC4);
- Reinstall the casing after cleaning;
- Check at least once a year the connection of each cable (for loose connections, etc.);
- Keep the battery charger dry, clean and in a dedusted area to ensure a good dissipation of heat.



WARNING

All maintenance operations listed must be performed only by skilled personnel.



DANGER

NEVER obstruct the air intakes of the battery boxes as natural ventilation must always be allowed so that the batteries do not overheat.

Charge output

For a good operation, batteries must not be discharged below 30-40% of their capacity, therefore, always start recharging them, when this charge level is reached.

The battery charger is equipped with a temperature sensor located close to the batteries. According to the temperature value detected, together with the value of residual capacity of the batteries, the charger automatically adjusts the charging voltage according to temperature, thus remarkably increasing battery life. Moreover, besides the thermal compensation, the battery charger can also compensate the voltage drop due to the dispersion of the connection cables. The battery charger is provided with an integrated warning light which activates in case certain adjustment values are exceeded.



WARNING

With running engines, the alternators are charging the batteries so it is advisable to keep the charger switch set to OFF, in order to avoid damaging the alternator.



CAUTION

If the battery voltage drop under 18 V, the battery charger will supply a current corresponding to the 25% of the maximum one and the recharge time will consequently increase.

7.9 INVERTER SERVICES

Operation:

The inverter is a completely automatic device and of high efficiency. The inverter transforms the 24V DC voltage into 120/240V AC.

- **Switch ON**
Position the ON/OFF switch, located on the front panel of the inverter to "ON". The green light "inverter on" lights up and the inverter starts.
- **Switch OFF**
Position the ON/OFF switch, located on the front panel of the inverter to "OFF". The inverter stops and all lit lights switch OFF.



Warning lights:

The functions of the warning lights located on the inverter front panel are:

- **Inverter ON**
The green light indicates when the inverter is ON.
- **Overload**
Light lights up when the inverter is overloaded. When the inverter is overloaded, the power limiter reduces the voltage output. According to the load, the inverter will switch OFF after a short period.
- **Overload + ON slow**
When the inverter remains overloaded for a long period of time, it will switch OFF and the "overload + ON" indicators will blink slowly. This takes approx. 20 seconds, after which the inverter will restart automatically. This is called "wait state" and gives the inverter time to recover from any heavy surge load and gives the battery time to recover in case it is flat.

- **Overload + ON fast**
The inverter is switched OFF. When the inverter switches OFF 10 times with intervals no longer than 30 seconds, the inverter will switch OFF permanently and the "overload" and "ON" indicators will blink fast. To switch the inverter ON again, you have to switch the inverter OFF and ON again.
When the output terminal is short-circuited, the inverter will overload. The "overload" and "ON" indicators will blink slowly. The inverter will try to start up ten times. If the short-circuit is not removed, the inverter will switch OFF permanently. Remove the short circuit and reset the inverter by switching it ON and OFF.
- **Low battery (nearly flat)**
The inverter is OFF when the battery voltage is too low. If the voltage increases above certain values, the inverter restarts automatically.
- **Temperature**
The inverter switches OFF in environments at high temperature and/or remarkable overload. After the cooling, the inverter starts automatically.



DANGER

When disconnecting the inverter by means of the switch located on the front panel the connection with the mains is not broken OFF.

NOTE

For further information on use and maintenance, please refer to the manufacturer's manual.

7.9.1 Inverter services maintenance

Component	Maintenance	Notes and precautions
Inverter (services/refrigerators)	Maintenance and check	<p>At least once a year, have the cable and wire connections checked by skilled personnel; they should still be tight and not oxidized.</p> <p>Keep the inverter/battery charger dry, clean and away from dust to ensure a good heat dissipation. Periodically check the good condition of the cooling fan.</p> <p>If the device is OFF during the maintenance and/or repair works, it should be set to prevent an unexpected or unintentional activation:</p> <ul style="list-style-type: none"> • Switch OFF the connection with the batteries or remove the inverter fuse; • Make sure that nobody can tamper with the precautions taken.



DANGER

Do not work on the inverter or on its system if still connected to a current source. Only qualified staff can carry out interventions on the electric system and only after the approval of RIVA.



WARNING

The uses supplied by the inverter highly stress the batteries that could discharge as a result.



DANGER

Have the inner condition of the inverter checked at least once a year by skilled personnel. Faults like loose connections, burnt wires, etc., with following fire break risks, must be removed immediately.

MAINTENANCE

At least once a month check the correct operation of the inverter.
 At least once a month carry out the complete cleaning.
 At least once every six months protect the contacts with proper products.

7.10 GENERATORS

On board of your yacht, two generators are installed in the engine room.

On the fuel tank flange, you can easily see the generator's power supply, which can be cut-OFF by means of the two suction valves, on which you can handle quickly to cut-OFF the fuel lines in case of emergency in order to disconnect the generators. The connections going from the generators to the tank are for fuel flow-back.

The fuel, before being sent to the generators, is passed through the separator filters in order to retain the dirt particles and separate any water present (optional).

The exhaust gases, instead of being discharged directly overboard, are conveyed through mufflers, one on each generator placed next to them. These mufflers, by injecting water in the exhaust pipes, allow cooling down the fumes and, at the same time, reducing the noise produced by the water outflow.

To further reduce the noise, the fumes are then sent to the separators. The separators use the gravity and centrifugal forces to separate exhaust gases from cooling water.

This latter is separated and discharged directly under the water line. The exhaust gases without water are then conveyed and discharged overboard.

The sea cocks of the cooling circuit are installed on the hull with the sea water strainers, fastened to a surface close to the sea cocks valves.

Clean the sea cock strainers according to the use frequency and to the condition of the sucked waters (seaweeds, mucilages, etc..).

Before cleaning the strainers, remember to close the sea cock valves, to stop the generators and then to proceed with maintenance. Once this cleaning operation is completed, reopen the valves supplying the cooling circuit. As to the unit supply, on each power generator set is located the control panel for the check and start/stop operations.

The generators are also equipped with battery breaker switches.

The dashboard control panel monitoring and controlling the main operating parameters (oil pressure, coolant temperature, rpm, etc..) of the generators, in order to detect any alarm situation or potential risk.

NOTE

For further information on use and maintenance, please refer to the manufacturer's manual.

Generator exhaust diagram:

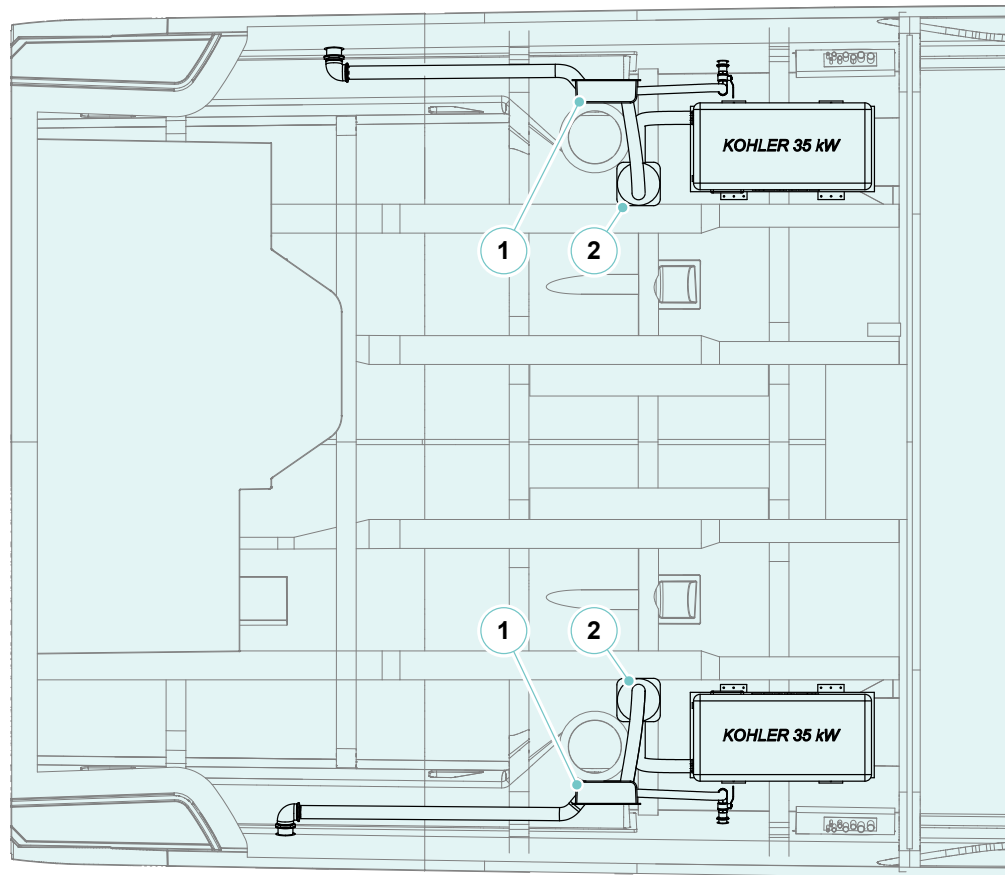

ICONA ICON	DESCRIZIONE DESCRIPTION
1	Separatore acqua/fumi Water/fume separator
2	Silenziatore generatore Generator muffler

7.10.1 Power generator control panel

Description

On the power generator there is a control panel allowing to carry out the controls and the start/stop operations.

A display indicates, by means of the relevant warning lights, the fault detected, thus allowing the monitoring of the power generator set.

NOTE

For further information on use and maintenance, please refer to the manufacturer's manual.



WARNING

Before stopping the power generators, disconnect the various on-board uses supplied by them; stopping the power generators under load can irreparably damage the electronic control units of the various uses, beyond having a negative influence on the generators' operation.

However, please refer to the manuals of the power generators to obtain more detailed information about the starting and stopping procedures.



DANGER

CARBON MONOXIDE POISONING

Start the generator only in a well ventilated area. The carbon monoxide, generated by the inner combustion of engines, is extremely toxic.



DANGER

EXPLOSION/FIRE HAZARD

Check for the presence of fumes in the generator area.

7.10.2 Generator maintenance

Component	Maintenance	Notes and precautions
Lubrication system	Oil specifications	Use specified oils according to Manufacturer's indication.
	Oil check	Check the oil level in the crankcase daily or before each start-up to ensure that the level is in the safe range. Remove the level rod, clean the end, reinsert as far as possible, and remove. Maintain the oil level between the marks (Min and Max).
	Oil change	<p>For the oil change remove the draining hose from its holder. Position the hose in the oil collecting container. Remove the oil filling plug. Open the oil draining valve located on the engine and drain the oil completely in the container. Change oil according to intervals suggested by the Manufacturer.</p> <div style="border: 2px solid yellow; padding: 10px; text-align: center;">  <p>CAUTION</p> <p>Do not mix different oils.</p> </div>
Fuel system	Cleaning and replacement of fuel pre-filter	Replace fuel pre-filter at time intervals recommended by the Manufacturer.
	Cleaning and replacement of fuel filter	Close the fuel supply valve. Loosen the fuel filter by turning it counter clockwise. Remove the filter and clean the contact surface. Tighten the filter on the adapter until the seal comes in contact. Replace fuel filter within the intervals indicated by the Manufacturer.

Component	Maintenance	Notes and precautions
Cooling system	Cleaning / replacement of the air cleaner	Release the two spring clamps and remove the cover of the air intake. Clean the cover and the base with a clean cloth so as to remove the dirt. Refit the filter and the cover at the base of the filter air intake. Replace the filter at time intervals recommended by the Manufacturer.
	Cooling liquid top up	Before filling the cooling system stop the generator and let it cool down. Close the draining taps. In order to discharge the pressure turn slowly the plug clockwise up to the first stop. Remove the plug after the pressure has been completely released.
	Sea water strainer	At least once a week check for the correct water flow through the strainers. At least once a month check the integrity of the strainers. At least once a month clean the suction strainer. At least once every six months check the condition of the cover seal.



ENVIRONMENT

Recover all waste materials (engine oil, fuel, filter, etc..) according to the rules in force concerning the special waste disposal.



CAUTION

Failure to observe the oil specifications may cause inadequate lubrication/oil pressure and cold-starting difficulties.



DANGER

Hot coolant and steams may cause heavy injuries or even death.



CAUTION

If the oil level is not positioned between the two reference notches do not activate any device.

**CAUTION**

Pay special attention to the coolant level. After the coolant drains, allow time when re-filling the coolant for a complete refill of the engine water jacket.

Check the coolant level as prescribed in the Pre-start Checklist.

**CAUTION**

For detailed information refer to Manufacturer's Manual.

**CAUTION**

Damage due to sea water. Sea water quickly deteriorates metals. Wipe up sea water on and around the generator set and remove salt deposits from metal surfaces.

**CAUTION**

Do not add coolant if the engine is still hot. Adding coolant to an hot engine can cause the cylinder block or cylinder head to crack. Wait until the engine has cooled down.

7.11 REFRIGERATOR SYSTEM

On this kind of yacht is installed a galley refrigerator with freezer, operating at 120/240V (it also operates by means of dedicated inverter).

The galley refrigerator is powered by a 24 V/2500 VA inverter (1) that allows it to be operated with 120/240V power both from the shore and with the inverter itself.

In order to avoid a parallel connection between the 120/240V mains and the inverter outlet, which could damage the inverter, a switching system has been arranged and equipped with two inputs: one for the shore connection and the other for the inverter connection and a connection for the AC system.

When shore supply is available, the galley refrigerator operating at 120/240V will be automatically supplied and the inverter will hold in stand-by.

Should the shore supply fail, the switch will automatically switch over to the inverter, supplied on its turn, by the user batteries. This will enable the inverter to supply the galley refrigerator.



CAUTION

Remember that the services batteries have a limited charge, therefore, during their use check periodically their charge status and eventually proceed with recharging.



Riva

102 CORSARO *supera*

PROPULSION SYSTEMS

CHAPTER 8

8.1 PROPULSION SYSTEMS

In the engine room and steering unit compartment are assembled all components for the yacht thrusting.

The propulsion system consists of two equal units.

Each one includes:

1. "MTU" engine model. 16V 2000 M96L
2. Mechanical seal
3. Propeller shaft
4. Propeller shaft support
5. Propeller
6. Rudder

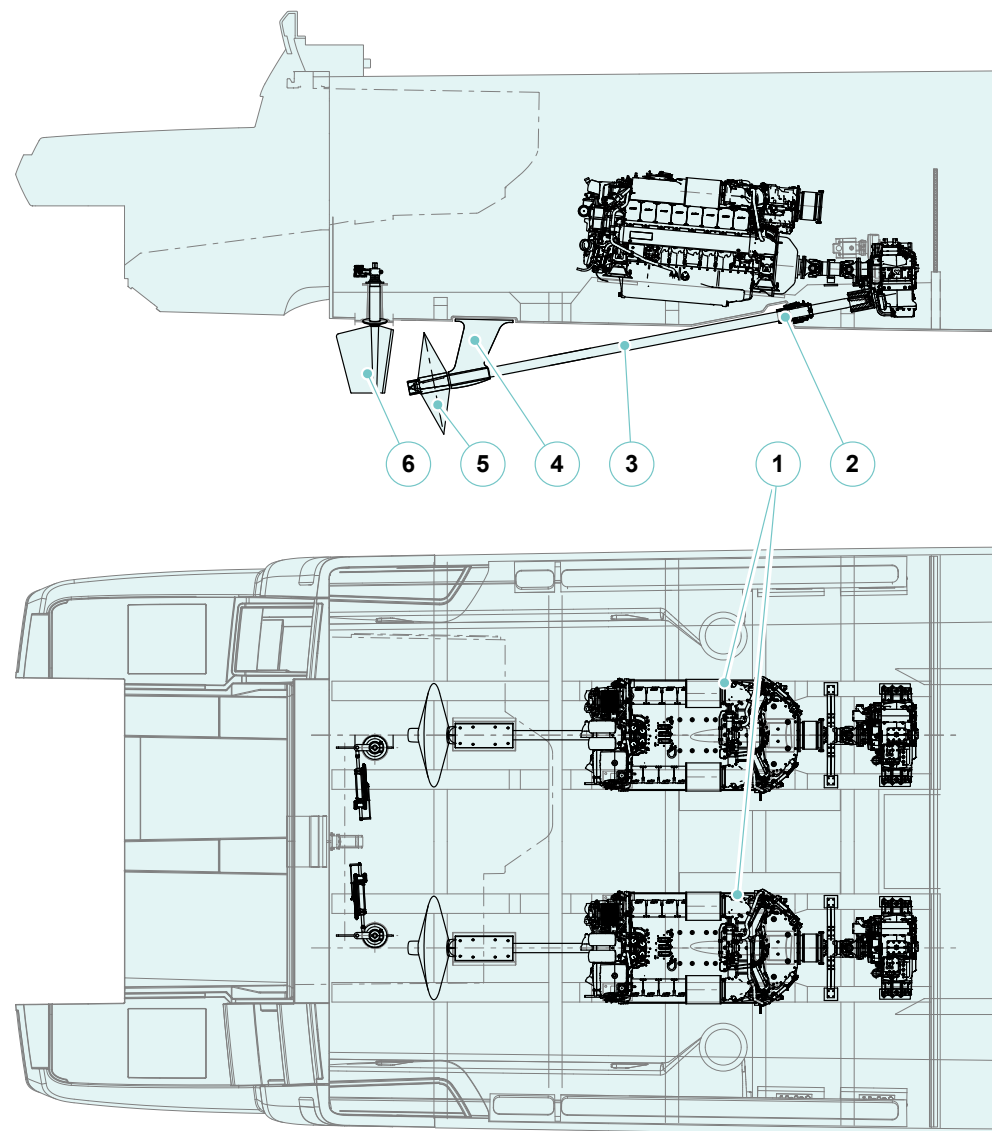

8.2 ENGINES

They have following features:

- | | |
|--------------------|------------------|
| • Model | 16 V 2000 M96L |
| • Make | MTU |
| • No. of cylinders | 16 |
| • Effective output | 1939/2638 kW/mhp |
| • Rated speed | 2450 rpm |
| • Dry weight | 3450 kg |
| • Displacement | 35,70 l |

For any problem related to the use or maintenance of the engines, refer to the specific manuals or directly to the Service Centres.

NOTE

For further information on use and maintenance, please refer to the manufacturer's manual.



CAUTION

Do not operate the yacht with an engine of rated power greater than the maximum recommended power (actual power engine series).

Among all the possible interventions to carry out on the engines in case of need (see the operating instruction manual) these are the most useful, according to our experience:

- Replacing the fuel filters.
- Replacing the oil filters.

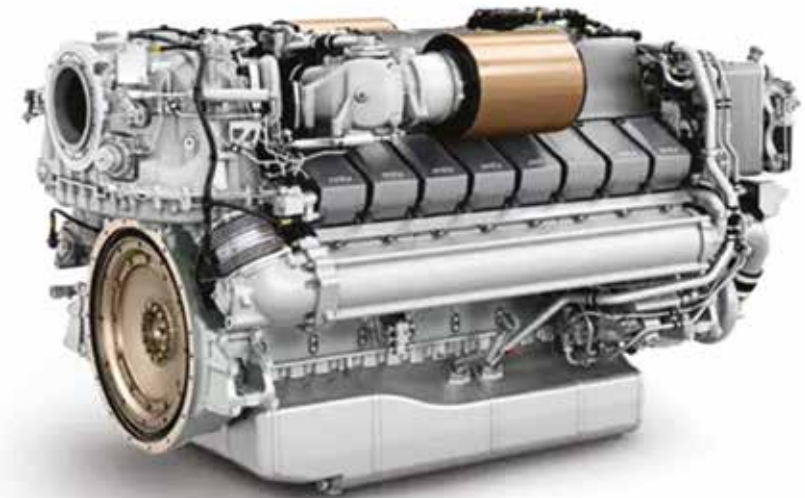

**CAUTION**

The engine data boards are very important in case of repairs. Therefore keep them with care together with the warranty.

Remember that you can obtain a flawless operation and a high power only by respecting the prescribed maintenance intervals and by using the specified fuels and lubricants.

The engines have been installed on suitable elastic supports, which absorb vibrations and allow the minimal motion of the engines; in this way structures and devices connected with them are not damaged.

Moreover, elastic supports allow easy adjustment of the position of the engines, during new installation or after the expected adjustment.

8.3 ENGINE CONTROL PANEL

This station must be used only in case of emergency. The controls on the panel allow all procedures for yacht navigation to be executed in “Local” mode.



CAUTION

When driving the yacht at “local” station, require the help of three people: one for the yacht’s controls, the second on the engine room door transmitting the indications to the third person controlling the “local” station.

NOTE

For further information on use and maintenance, please refer to the manufacturer’s manual.

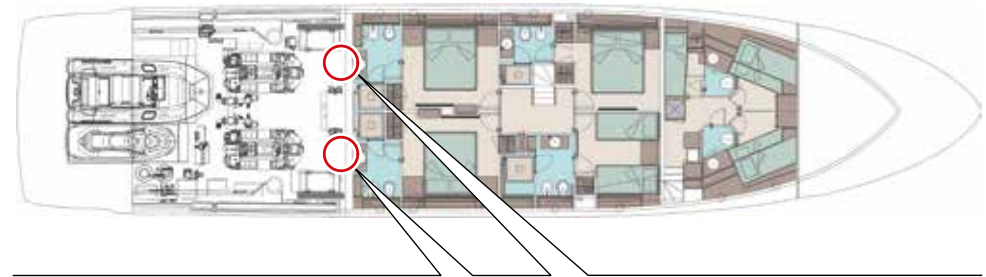

8.4 START OF PROPULSION ENGINES

Commissioning

When setting a new or overhauled engine into operation pay attention to the technical publication. During the first service hours it is advisable to have new engines run not over 75% of their maximum load and at variable speeds. After this initial run-in, the engine should be brought up to full output gradually.



CAUTION

Use only approved technical fluids; otherwise the Manufacturer's warranty will become null and void and the engines can get seriously damaged.

Daily start-up

Before daily starting the engine, check fuel level, coolant level and engine oil level and replenish, if necessary. In case of need, fill with fuel, coolant and oil mix.



CAUTION

Engines must always be started with gear boxes at idle run and throttle levers set at minimum speed.



DANGER

Before starting an engine, ensure that nobody is standing in the dangerous area of the engine room.

Cooling liquid

Fill the cooling system of the engine with a mixture of drink water and anti-freeze or anti-corrosion agent.

- Pour in coolant slowly in the expansion tank through proper filler.
- For the proper quantity of coolant, see "Technical Data" in the Manufacturer instruction manuals delivered.

Engine oil



CAUTION

Do not top up oil so to exceed the MAX notch of the control rod. If the oil level is too high, damage to the engines may occur!

Pour lubricating oil into engine by means of proper filler neck.
For proper quantity of lubricating oil, see Manufacturer instruction manuals.

Sea water suction pumps



CAUTION

Do not let raw water pump run dry! Make sure that all valves of the raw water circuit are open.
Drain the pump in case of freezing danger.

Oil level check

Check engine oil level only approx. 20 minutes after the yacht has been switched OFF.

- Pull out control rod for oil level check.
- Wipe it with a clean, dry and lint-free cloth.
- Place it back up to retainer.
- Pull out control rod again.

The oil level should set between the two notches in the control rod and must never fall below the MIN notch.

Top up oil as necessary

Ensure utmost cleanliness when handling fuels, lubricants and coolants.



CAUTION

Do not top up oil so to exceed the MAX notch of the control rod. If the oil level is too high, damage to the engines may occur!

Waste oil drain

It is possible to drain the used oil from the propulsion engines by using a manual pump activated by means of the relevant lever.

Procedures for start-up

- Verify that the main electrical panel in the crews' corridor and the electrical panels for engine electronics in the engine room are fitted with the following functional uses of the yacht: engine start, exhaust fans, navigation lights, dashboard lights, manoeuvring thrusters, mooring winch, horn, VHF, radar, autopilot, control panel, GPS/Navigator, plotter, and depth sounder.
- Move the control levers (4) and (5) to the neutral central position.
- Turn the right engine ignition key (10) to the "ON" position, the thrust levers will emit a short beep, then press the "CMD" button (7). The "COMMAND" indicator light (8) on the thrust lever block indicates that this helm position now has control. The control system is ready for operation. Then proceed by pressing the engine "START" button (9).
- Check that the oil pressure settles to the normal value within 10 seconds.
- Check the correct circulation of the cooling water.
- Start the first engine and, only after it has been established that it is running properly, start the second engine as well.
- Start the left engine as described for the right one.
- Turn the left engine ignition key (10) to the "ON" position, the thrust levers will emit a short beep, then press the "CMD" button (7). The "COMMAND" indicator light (11) on the thrust lever block indicates that this helm position now has control. The control system is ready for operation. Then proceed by pressing the "START" key (12).
- Heat the engines for about 2-3 minutes at 1000 rpm maximum.
- Check the charge of the alternators.
- Activate the manoeuvring thrusters by operating the control panel on the helm station.

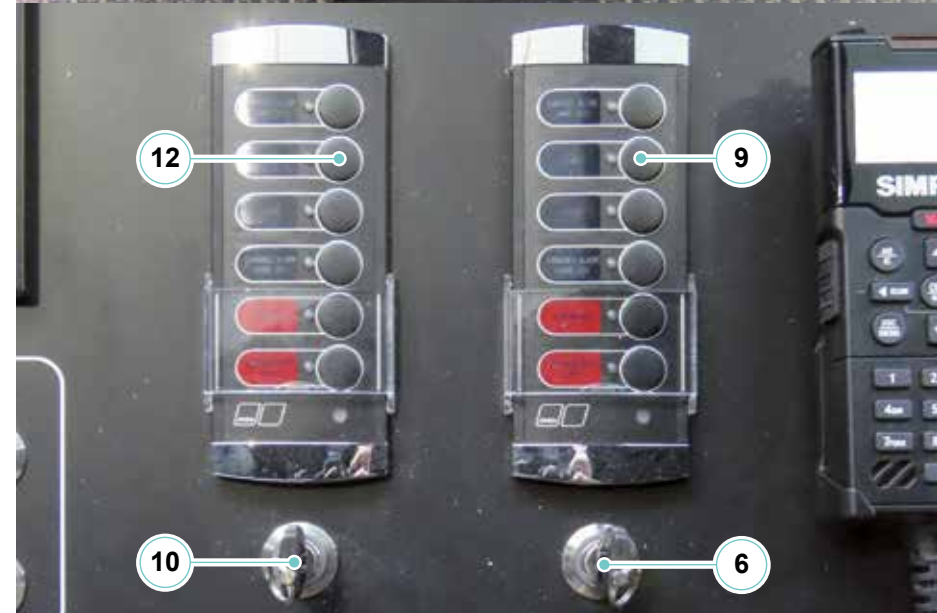
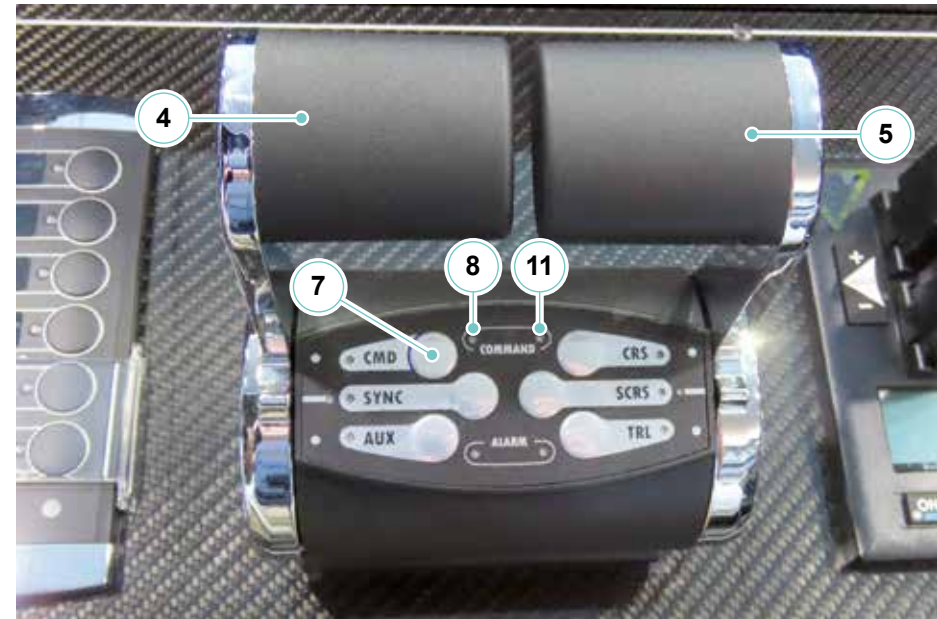

Throttle operation

- Bring both throttles to the “**NEUTRAL**” position (4) and (5) (vertical levers).
- Press the “**CMD**” button (7) from the workstation you intend to use (the lights indicating successful transfer will light up).
- Press the button corresponding to the mode you want to activate:
 - **CRS**: cruising mode;
 - **SCRS**: Smart cruise mode;
 - **TRL**: Trolling mode;
 - **SYNC**: Synchronisation mode;
 - **SCL**: Single control lever.

**CAUTION**

If you have to connect the batteries in parallel for the start-up of the propulsion engines, it is suggested to disconnect the electric devices in order to avoid current rushes or drops.

**CAUTION**

In the event of the intervention of a magneto-thermal protection, do not try repeatedly to reset it, but check the relevant electric system condition.

**CAUTION**

We suggest avoiding slow running for periods longer than 5 minutes. The slow run implies major wear of the engine mechanical parts and is the most harmful from the point of view of polluting exhaust.

8.4.1 Engine drive

Despite the efficiency and the high performances of the yacht, and in particular the sensitivity to rudder motion, which allow an immediate response to the controls, the use of this yacht requires a careful and responsible behaviour.

In the passage between displacement and gliding navigation there is a critical phase to be carried out as quickly as possible, as it is characterized by high consumption and more vibrations; it also causes a very deep wake.

The minimum gliding speed is influenced by the displacement, the distribution of the weights on board, the position of the interceptors and the sea conditions. The excellent choice and quality of the engines allows keeping high speeds for a long time with no consequences.

In order to achieve the best compromise between comfort and speed, while minimizing fuel consumption, it is recommended to keep the engine operating speed in the range between 1500 and 2000 rpm.

Do not keep the propulsion engines at idle run for a long period of time; this to prevent them from getting “dirty” or overheated.

Avoid harsh accelerations or decelerations to avoid excessive stresses for the engine turbines.

When the yacht reaches the cruising speed, the engine check instruments should set to constant values.

If the instruments show contrasting or abnormal indications during continuous run, check for failures of the systems or of the equipment and contact Assistance Service.

**CAUTION**

Even if the automatic pilot controls the route, navigation must be supervised in any case.

**CAUTION**

During navigation, keep rear window closed to avoid the introduction of exhaust gases and water splashes into the main deck compartments, under special conditions of wind direction and force.

This will improve comfort for the passengers and silence inside the compartments.

**CAUTION**

The speed of the yacht must be controlled, together with the position of the interceptor, according to the sea conditions and the prevailing wave direction, so as not to subject the structure of the yacht to avoidable stress and assure the occupants' comfort when underway.

**DANGER**

It is absolutely forbidden to perform reverse run with one of the two engines stopped. This operation is allowed only in case of life danger for the people on board and for the safety of the yacht itself, however when the engine is running it should not run higher than 1000 rpm.

**WARNING**

Avoid prolonged use of low speed engines to avoid overheating of the exhaust ducts due to reduced circulation of cooling water.

8.4.2 Checks after start of propulsion engines

- Check that water comes out of the exhaust pipe and, in case it does not, slightly accelerate with engine idling for a few seconds. Otherwise stop engines, troubleshoot the problem or call for Assistance Service.
- Run the engines slightly higher than idle run until they have reached the operation temperature.
- Check for abnormal noises or excessive smoke. Otherwise stop engines and call for Assistance Service.
- Check that alternators load the batteries.
- Verify the efficiency of the instrument system from the plotter to the radar, VHF, compass, etc..
- Plug out the shore cable if connected.
- Remove moorings and check for loose mooring ropes or floating objects hindering the propellers' movement.

**DANGER**

Make sure that no crew stands in front of gas exhausts and near the mooring ropes.

8.5 STOP OF PROPULSION ENGINES

Do not immediately stop the engines after a full-load operation, but let them run low (about 5 minutes) to balance the temperature differences.

From inner helm station

- Recall the position levers (1) and (2) of the inverter's neutral centre.
- Press the "STOP" buttons (3) and (4) on the engine control panels.
- Turn the keys (5) and (6) to the OFF position.
- Disconnect the magneto-thermals related to the starter keys of the two engines.



CAUTION

With engines stopped carry out following:

- Disconnect all unnecessary electric uses and check the general status of the switchboard as well as the voltmeters and ammeters indications;
- Check the switches of the bilge pumps and their regular operation;
- Check for possible leaks from the shaft lines seals;
- Rinse the yacht with fresh water;
- Connect the shore electric power supply;
- Keep the engine room extractor running for about 30 minutes, for ventilation and air cooling.

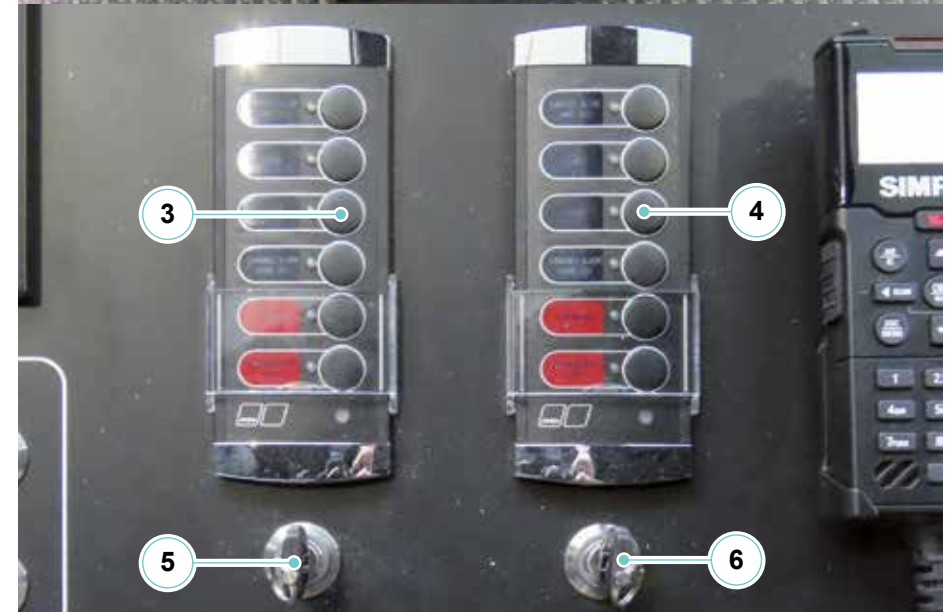

From fly helm station and/or third station

- Recall the position levers (1) and (2) of the inverter's neutral centre.
- Press the "STOP" buttons (3) and (4).
- Go to the internal bridge and turn the keys to the OFF position.
- Disconnect the magneto-thermals related to the starter keys of the two engines.



DANGER

Make sure that the engines cannot be started by unauthorized staff.



8.6 ENGINE EMERGENCY PROCEDURE

Due to a mechanical or electrical fault, the normal procedures for engine stop might not be sufficient; it is therefore necessary to stop the engines with the EMERGENCY procedures.

- **EMERGENCY STOP buttons**
The EMERGENCY STOP buttons are installed in the inner and third helm station: press and hold them until the engines stop.
- **From the engine room with "local" station**
Reach the engine room and the engines control panel; press the EMERGENCY STOP button.



CAUTION

The emergency stop causes heavy stress on the engines with consequent hazard of component damage. Use only in case of real need.



DANGER

Before restarting the engines after an emergency stop, make sure to find and to clear the reason of the fault.



WARNING

The engines emergency stop controls must be used only in case of real emergency.
Never use these controls during the normal engine stop procedure.



8.7 PROPULSION ENGINE MAINTENANCE

Component	Maintenance	Notes and precautions
Lubrication system	Replacement of the oil separator filter	Replace the separator filter, according to the time intervals suggested by the Manufacturer.
	Oil level check	Check the oil level by means of the special control rod; make sure the level is included in the allowable range (MIN - MAX). Do not start the engines if the oil level is not included between the two reference marks, as indicated in the Manufacturer's Manual.
	Oil and oil filter replacement	Replace engine oil according to time intervals and oil type suggested by the Manufacturer.
Fuel system	Fuel filter replacement	Replace fuel filter within the intervals indicated by the Manufacturer.
	Air cleaner replacement	Replace air filter within the intervals indicated by the Manufacturer.
Cooling system	Coolant check	Make sure the coolant is in the tank (lever sensor, reference plate, built-in eyelet).
	Cooling system filling	For coolant features refer to the User's Manual of the Manufacturer.
	Cooling system drainage	Drain the coolant only when the engine is stopped; follow the procedure indicated by the Manufacturer.

**DANGER**

A wrong use, a wrong maintenance, tampering and replacement of pieces, can cause serious damages or mortal events, beyond damaging the equipment.

The interventions on the electrical and mechanical equipment must be carried out by qualified staff after having examined the Manual delivered by the Manufacturer.

**ENVIRONMENT**

Dispose of waste materials (engine oil, fuel, filters, etc..) with respect for the environment and according to the laws in force.

Use only authorized disposal procedures, in case of doubts, contact the Port Authority.

**DANGER**

Any maintenance procedure on the engines is to be carried out with engines shut OFF, after they have sufficiently cooled down and after seeing to the prevention of their being switched on by disconnection of the magneto-thermal switches.

**CAUTION**

Use only approved fuels, otherwise the Manufacturer's warranty will become null and void.

**CAUTION**

Do not top up oil so to exceed the MAX notch of the control rod. If the oil level is too high, damage to the engines may occur!

**CAUTION**

Do not use open flames, do not generate electric sparks. Do not smoke. Avoid ignition sources. Risk of fires and explosions!

**DANGER**

Compressed air at high pressure may create the risk of injuries. Do not direct compressed-air jets at persons. Wear protective goggles, safety masks and ear protectors.

**DANGER**

Hot oil can contains combustion residues which are harmful to health. Risk of injury and scalding! Wear protective clothing, gloves and goggles/safety mask. Avoid contact with skin. Do not inhale oil vapour.

**DANGER**

Because of the high temperature in the engine room, oil or fuel leaks can evaporate and create a serious risk of fire. Regularly check the integrity of the system.

**CAUTION**

It is absolutely necessary to view with RIVA the documentation of the different components provided by the Manufacturer; for any problem relevant to the use or maintenance, please directly refer to the Service Centres, listed in the documentation provided by the Manufacturer. In any case there are some small procedures that can be carried out by the crew on board, after consulting the operation manual.

**ENVIRONMENT**

Handle used fuel filters as special waste.

**DANGER**

Coolant is hot and under pressure. Risk of injury and scalding! Let the engine cool down and wear protective clothing, gloves, goggles and safety mask.

**CAUTION**

Cold coolant in a hot engine causes thermal stress with the risk of formation of cracks in the components. Fill/top up only a cold engine.

**CAUTION**

If the oil level is not positioned between the two reference notches do not activate any device.

8.8 FUEL SYSTEM

The fuel tank is built with fibreglass according to ISO 10088 standards and is located at bow in the engine room under the flooring of the VIP's cabins. The tank is filled through two filler necks, located inside two suitable peaks placed along the side walk-arounds of the yacht.

The fuel level is detected by a sensor and is visible by means of the control panel, located in the main station.

It is possible to monitor the level in the tank also by means of a visual gauge, attached directly on the fuel tank flange. This gauge can be actuated by means of a ball valve and a push-button valve, and it must be activated to check whether the transmitted value corresponds to the real level of fuel inside the tank.

Your yacht is equipped with a fuel treatment system.



CAUTION

It is a good rule, before each navigation, to check again the fuel level also by means of the visual check installed on the tank flange.

NOTE

The level indicated without operating the valve refers to the last check.



CAUTION

While checking for consumption and distances, it is a good rule to always keep plenty of margin, so as to be able to face bad weather conditions or other possible unexpected events.

The fuel is sucked directly from the tank and is sent to the distribution manifold, which supplies the engines and the generators.

The fuel sucked, before reaching the uses, flows through the water/fuel separator filters holding impurities and separating possible water in the fuel.

During boarding, the fuel flow produces a lot of foam; if this comes out, you might think the tank is full. Therefore, it is good to wait for a few minutes and then top up, in order to be sure that the tank has been filled correctly.

The particular geometric shape of the tank allows the decantation of impurities in the fuel tank.

It is appropriate to fill the tank some hours before setting up for navigation, in this way the impurities in the fuel will settle down and water will decant as they are both heavier than fuel.

The tank is drained through a manually operated valve located on the consumer flange.



CAUTION

The draining should never be conveyed to the bilge. If accidentally the draining is conveyed to the bilge, disconnect the bilge pumps and clean accurately.

To avoid fuel fumes, the tank has been equipped with two vent manifolds and a flame trap.

The activation of the fire-fighting system implies the closure of the fuel cut-OFF valves.

**WARNING**

The sensor reading can be distorted by the temperature, because the specific weight of fuel varies according to this last parameter and to the yacht trim. Therefore before setting-up for navigation, always refer to the visual level in the engine room.

**WARNING**

The bilges of the engine room must always be kept clean, so that fuel or oil leaks or penetrations from the engines or the generators can be easily noticed. If leaks are noticed, it is necessary to stop the engines and to let them cool and only afterward, if possible, repair the leak. Finally clean the bilges.

**ENVIRONMENT**

Every marina has dedicated toxic waste disposal areas. It is recommended not to scatter waste that can contaminate the environment (such as used oil, fuel, oily liquids, batteries, etc.).

Prior to perform any job in the engine room, disconnect the bilge pumps switches, to prevent accidental fuel, lubricant or other liquid leaks and therefore the pollution of the yacht surrounding waters.

**ENVIRONMENT**

It is forbidden to discharge bilge water mixed with oil or diesel fuel into the sea, because this can cause of serious pollution. Check periodically the level of possible oily waters contained into the collecting tanks under the engines, should their level be close to bilge over flooding, disconnect the magneto-thermals switches of the bilge automatic pump system, to avoid accidental spills, until the tanks have been completely drained in accordance with the environmental legislation. During the maintenance operation in the engine room, it is compulsory to disconnect the magneto-thermals of the bilge pumps automatic suction system, avoiding in this way accidental spills.

**DANGER**

Because of the high temperature in the engine room, oil or fuel leaks can evaporate and create a serious risk of fire.

**DANGER**

Fuel leak can cause a fire to break. Check regularly the integrity of the system.

**DANGER****EXPLOSION/FIRE DANGER**

- Stow flammable material in a safety-approved container. Never stow flammable material in non-vented areas.
- Check bilge and engine room for fumes.
- Keep the ventilation system free of obstructions. Never modify the ventilation system.
- Inspect the fuel system for leaks.

**DANGER****EXPLOSION/FIRE/POLLUTION DANGER**

Fuel system connections that are too loose or too tight can leak, resulting in fuel loss, environmental pollution and explosion/fire danger.

**CAUTION**

Be careful not to accidentally damaging the system fuel pipes.
Periodically carry out the verification of all the fuel pipes.

Fuel system diagram:

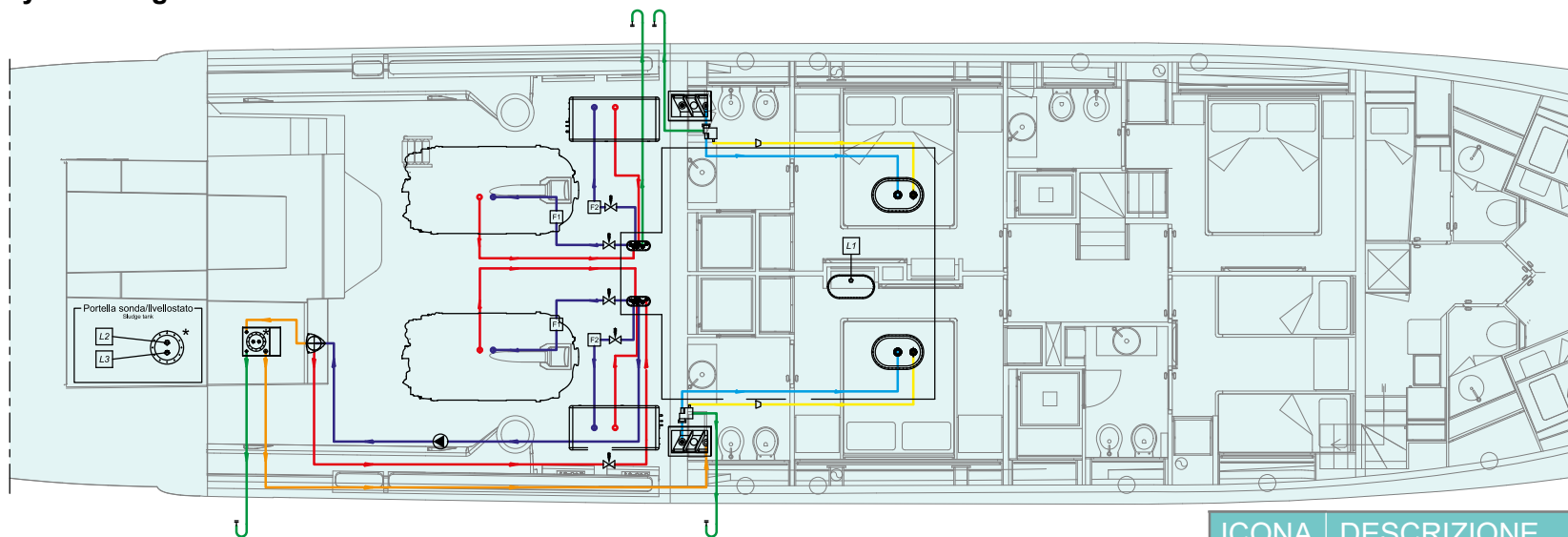

ICONA ICON	DESCRIZIONE DESCRIPTION
	Mandata combustibile Fuel delivery
	Ritorno combustibile Fuel return
	Sfiato Vent
	Imbarco Fuel inlet
	Morchie Alfa Laval Alfa laval sewage

ICONA ICON	DESCRIZIONE DESCRIPTION
	Linea anti rigurgito Overflow line
	Motore Engine
	Gruppo elettrogeno Diesel generator
	Valvola a scatto Fuel cut-off valve
	Prefiltro gasolio Fuel prefilter

ICONA ICON	DESCRIZIONE DESCRIPTION
	Prefiltro gasolio supplementare Diesel fuel prefilter
	Interruttore di flusso Fuel Splash-stop
	Sonda Sonde
	Livellostato (OPT) Fuel level (OPT)
	Sonda livello (OPT) Level sensor (OPT)
	Alfa laval (OPT) Alfa laval (OPT)
	Serbatoio morchie Alfa Laval (OPT) Sewage tank Alfa Laval (OPT)

8.8.1 Fuel inlet

The fuel inlet of the yacht is equipped with a flow switch having the function to prevent undesired leaks of fuel from the plug and from the vent which may stain the bridge and pollute the water. The leak of fuel may occur during refuelling, if the tank is almost completely full.

The fuel coming out of the intake duct is collected in a tank with suitable capacity, which, on its turn, will drain automatically into the on-board fuel tank, through the return duct. Also the flow switch is equipped with own air vent, bleeding from the wall near the filler plug of the tank.



CAUTION

The inlet plug carries the indication "DIESEL" to avoid accidental input of different fuels.



CAUTION

Filling lines pressure must be kept constantly under 0.3bar during bunkering operations.



CAUTION

Before refuelling, wash the teak with fresh water to avoid its contamination with fuel.



DANGER

During refuelling operations, do not approach open flames to the yacht; do not smoke. Carry out refuelling with engine shut OFF. Non-observance of these precautions may cause fire and injury.

8.8.2 Fuel quality

The quality of the fuel is crucial for a good performance of the engines installed.

Fuel should be purchased from reliable high-sale filling stations, for both the quality and a probable short stay of fuel inside the shore tank.

The fuels:

- European Standard EN590
- DIN EN 590 (Germany)
- ÖNORM EN 590
- ASTM D975 No. 1D (USA)
- BS 2869 Part 1 Class A 1 (United Kingdom)
- BS MA 100 DMX (Marine Diesel Fuel)

are suitable to supply the engines.

If the above type of fuel is not available in some countries, follow the rules indicated in the manual relevant to the engines.



CAUTION

Stop all engines when refuelling.



WARNING

For the type of fuel to be used, follow the manufacturer's recommendations. Diesel engines require very clean fuel. Keep filters clean.

8.8.3 Fuel system maintenance

Component	Maintenance	Notes and precautions
Fuel tank	Bleeding (at least every two or three refuelling and at least once a month)	As shown in the following sequence
Flow stopper	Fuel checks and cleaning	As shown in the following sequence
Water/fuel separator filters for engines	Maintenance and check Water drain from collection tank Replacement of filter element Troubleshooting procedure	As shown in the following sequence
Water/fuel separator filters for generators	Maintenance and water drain Replacement of filter element Troubleshooting procedure	As shown in the following sequence

FUEL TANK:

Bleeding

The tank is equipped with a flametrap vent and with a visual check of the fuel level. The gauge includes a lower valve to be operated in order to display the real level in the engine room. The geometric shape of the tank allows the decantation of possible impurities or water in the fuel. For the drainage of water and possible impurities embarked with fuel, it is necessary to wait for some hours after refuelling, so that the suspended particles have enough time to settle down.

Drain through the opening of drainage valve located on the flange. To this aim take off the blanking plug from the valve, open the valve slowly and let the water and the deposits drain into a container, until only clean fuel comes out. After the operation close the valve, disconnect the hose and reinsert the plug. In addition to the venting valve, the fuel supply valves for the engines and generators are also installed on the flange.

During the long periods of inactivity of the yacht, when the tank is empty, we suggest to open the flange and to remove the fuel deposits embarked during refuelling.



WARNING

The bleeding of tank is a special operation, that has therefore to be carried out by specialized person.

NOTE

The crew should always be present during this operation, as fuel leaks may occur in the engine room.

**WARNING**

During the tank inner cleaning, it is a good norm, to ventilate the room for a long time with the help of fans and to wear all necessary protections, to avoid injuries caused by gas fumes.

During the flange assembly, make sure that the screws are correctly and uniformly tight, in order to prevent leaks of fumes and fuel.

Furthermore, check the condition of the O-ring.

These are extraordinary maintenance operations, contact RIVA SERVICE in advance.

**CAUTION**

The draining should never be conveyed to the bilge. If the drained substances fall into the bilge, stop the bilge pumps immediately.

**CAUTION**

The bleeding procedure should be carried out every two or three refueling operations.

**ENVIRONMENT**

Handle water mixed with fuel and dispose of it according to the rules in force. Use only authorized disposal procedures; in case of doubt, refer to the Port Authorities.

**CAUTION**

We advise to drain and clean the tank periodically, at least once a year. Please remember that re-used fuel must be filtered.

**WARNING**

The bilges of the engine room must always be kept clean, so that fuel or oil leaks or penetrations from the engines or the generator can be easily noticed. If leaks are noticed, it is necessary to stop the engines and to let them cool and only afterward, if possible, repair the leak. Finally clean the bilges.

**ENVIRONMENT**

It is forbidden to discharge bilge water mixed with oil or diesel fuel into the sea, because this can cause of serious pollution. Periodically check the level of possible oily waters inside the collection tanks under the engines; should the level be next to overflowing into the bilge, disconnect the magneto-thermal switches of pumps of the bilge suction system, to prevent accidental spilling, until the bilge is empty, in compliance with current legislation for environmental protection. During the maintenance operation in the engine room, it is compulsory to disconnect the magneto-thermals of the bilge pumps suction system, avoiding in this way accidental spills.

MAINTENANCE

Check periodically the correct operation of the valves.
At least every three months check for the presence of leaks.
At least once every three months drain the tank.
At least once every two years carry out complete cleaning of the tank;
check anyway the draining according to the quality of fuel filled.

FUEL FLOW STOPPER:**Fuel checks and cleaning**

Regularly check for the air outlet valve and clean the screen if necessary.

At least each season begin and end carry out the following checks:

- Check for the anti-splash sleeve and replace if necessary;
- Check that pipes and connections are not leaking and install new pipes and/or clamps if necessary.

**CAUTION**

First place the filling nozzle as deep as possible into the filling pipe (through the rubber of the anti-splash sleeve), then use the nozzle to fill the tank.

**ENVIRONMENT**

Fuel is harmful to the environment. Prevent any spilling.
Keep oil absorbent rags within reach as a precaution!

8.8.4 Water/fuel separator filters for engines

Differential pressure – recording of indicator instrument with double switchable filter:

1. When the new cartridge is put into service, make the recording index (2) coincide with the pressure indicator (3) on the pressure indicator device (1);
2. Check the differential pressure as follows:
 - At full load or at rated engine power, read the pressure on the indicator instrument (1);
 - If the differential pressure between the indicator pointer (2) and the pressure indicator (3) is greater than or equal to 0.3 bar, wash the filter cartridge in service.

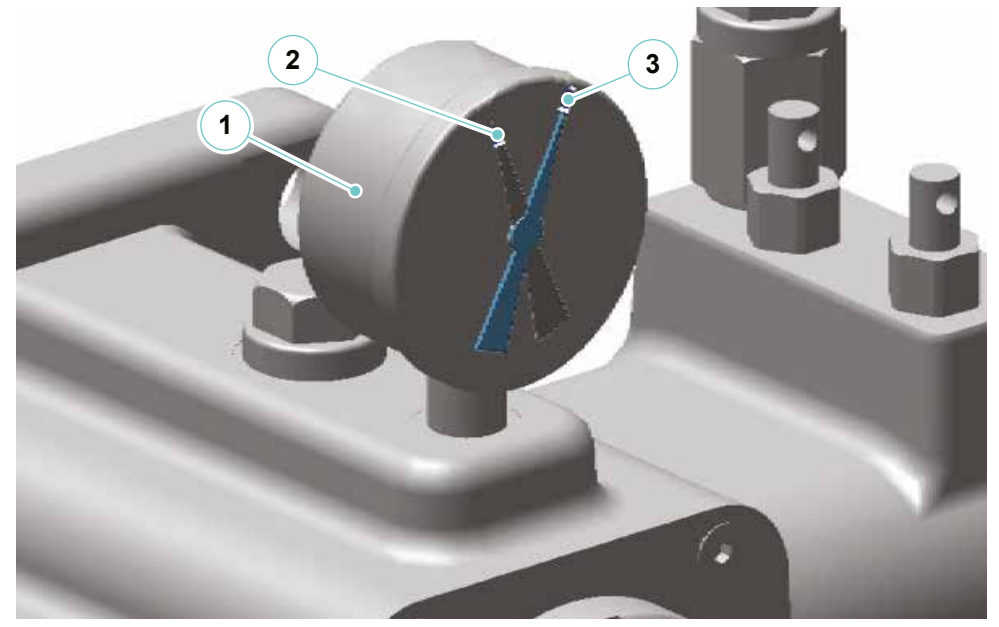

Drainage of the fuel pre-filter with double switchable filter:

1. Disable the filter to be drained (A) or (B) by turning the handle (7) towards the desired filter;
2. Loosen the vent valve (4) of the filter from which you wish to drain the condensate;
3. Open the drain valve (8) of the filter from which you wish to drain the condensate;
4. Drain the water and impurities from the filter until clean fuel comes out;
5. Close the drain valve (8) opened previously;
6. Connect the feed pump to the filling fitting (5) on the suction side of the filter;
7. Open the vent valve (4) and top up the fuel until fuel leaks from the vent pipe (6);
8. Close the vent valve (4);
9. Slightly turn the handle (7) (about 30°) and open the vent valve(s) (4), until fuel comes out of the vent pipe (6);
10. Close the vent valve (s) (4);
11. Turn the handle (7) to the deactivated drained filter position.

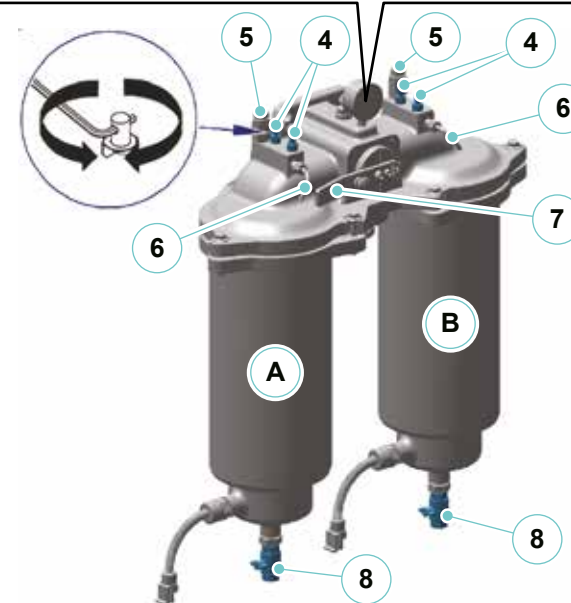

Rinsing of the fuel pre-filter with double switchable filter:

1. Disable the filter to be drained (A) or (B) by turning the handle (7) towards the desired filter;
2. Loosen the vent valve (4) of the filter to be rinsed;
3. Open the drain valve (8) and drain the fuel completely;
4. Close the drain valve (8) opened previously;
5. Close the vent valve (4).

Refilling of the fuel pre-filter with double switchable filter:

1. Turn off the engine making sure to prevent any unintentional ignition;
2. Connect the feed pump to the filling fitting (5) on the suction side of the filter;
3. Open the vent valve (4) and top up the fuel until fuel leaks from the vent pipe (6);
4. Close the vent valve (4);
5. Slightly turn the handle (7) (about 30°) and open the vent valve(s) (4), until fuel comes out of the vent pipe (6);
6. Close the vent valve (s) (4);
7. Turn the handle (7) to the deactivated drained filter position;
8. Check the differential pressure as follows:
 - At full load or at rated engine power, read the pressure on the indicator instrument (1);
 - If the differential pressure between the indicator pointer (2) and the pressure indicator (3) is greater than or equal to 0.3 bar, wash the filter cartridge in service.
9. If rinsing has not resulted in an improvement in differential pressure, replace the filter cartridge.

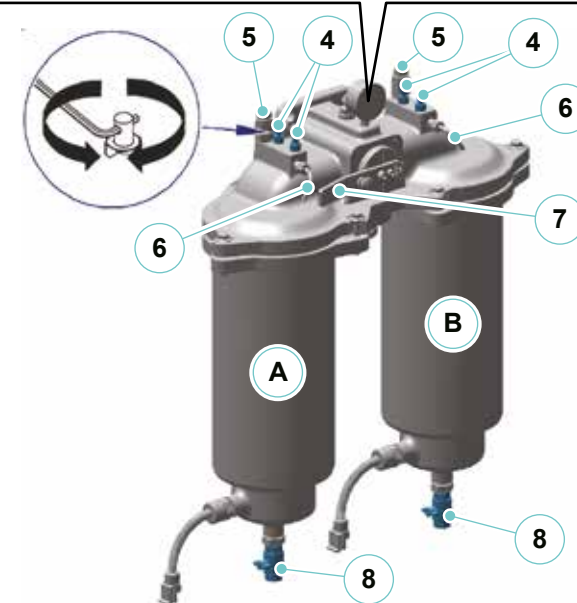
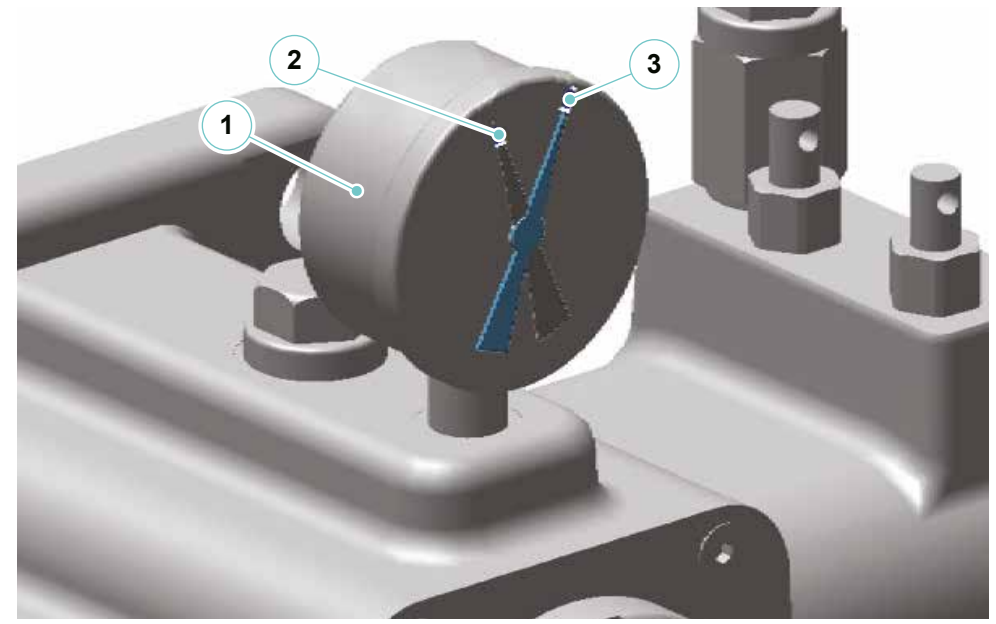

Replacing the fuel pre-filter cartridge with a switchable double filter:

1. Disable the filter to be drained (A) or (B) by turning the handle (6) towards the desired filter;
2. Loosen the vent valve (1) of the filter to be replaced;
3. Open the drain valve (5) and completely drain the fuel, water and impurities contained therein;
4. Close the drain valve (5);
5. Unscrew and remove the filter retaining screws (2);
6. Remove the elastic seal (3) and the filter cartridge (4);
7. Insert the new filter cartridge (4) and the elastic seal (3);
8. Refill the filter with clean fuel;
9. Replace the seal of the filter cover;
10. Place the filter under the cover and tighten the sealing screws (2);
11. Connect the disconnected filter;
12. Tighten the vent valve (1) after the fuel leaks;
13. Record the differential pressure indicator instrument as indicated above.

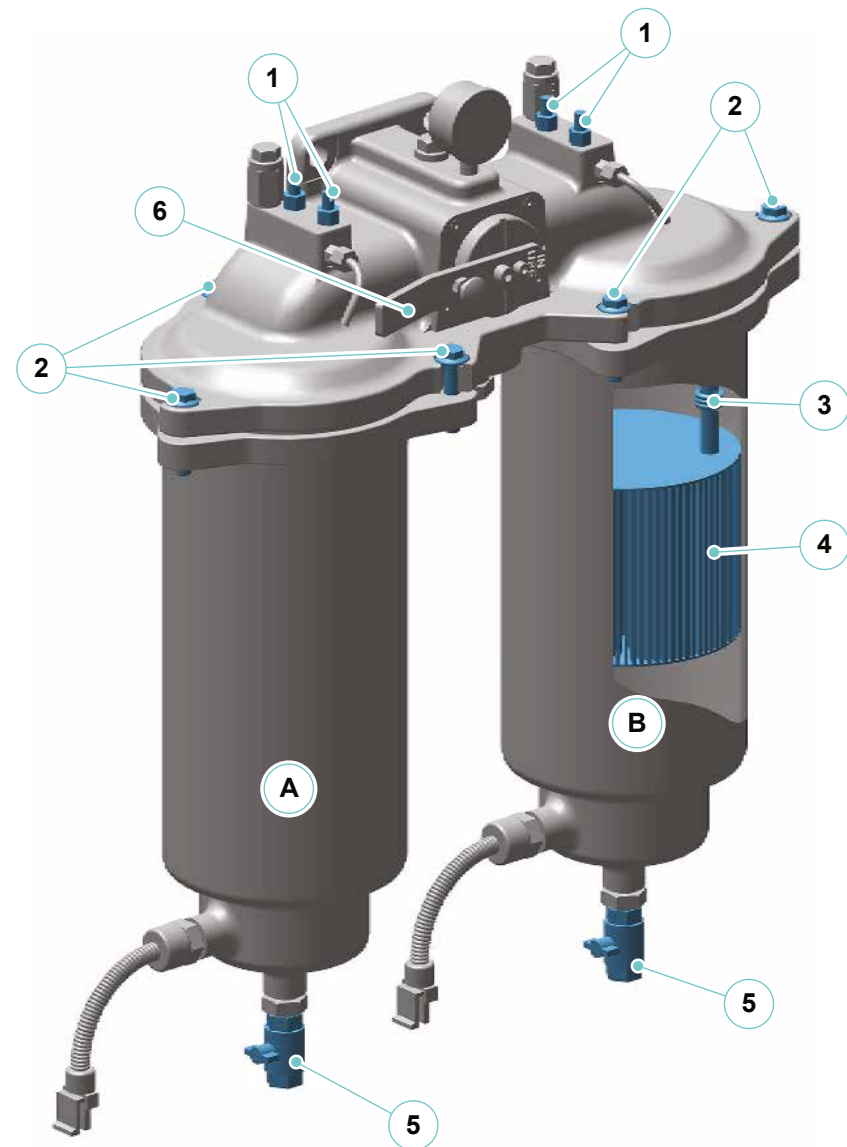

8.8.5 Water/fuel separator filters for generators

Maintenance and water drain from collection tank

Bleed frequency or the replacement of the filter element (1) are determined by the contamination level of the fuel.

Check or drain the water collection tank (2) daily.

The collection tank must be drained before containments reach the engine.

- After having placed a capacious collection container underneath it, open the drain to discharge containments.
- Remove the cover (3) and fill with clean fuel.
- Close the cover and tighten the T-handle (4) firmly by hand.

Replacement of filter element

Replace the element according to the schedule recommended by the manufacturer or if a lack of power is noticed. Power loss indicates that the element is indeed clogged. Other elements like a too full tank or excessively contaminated fuel can also clog the filter.

- Close the seacock.
- Remove the cover.
- Remove the element by holding the handle and by pulling lightly forward with a twisting movement.
- Insert a new filter having the same filtering features of the one replaced.
- Check and, if necessary, replace the filter cover gasket. Apply a layer of clean fuel or engine oil on the seal before reinstalling it, insert the new element with a slow twisting movement downwards.
- Fill with clean fuel, then replace the cover. Tighten the T-handle manually and reopen the valve.
- Start the engine and ensure there are no leaks. Repair any leaks with engine shut OFF.

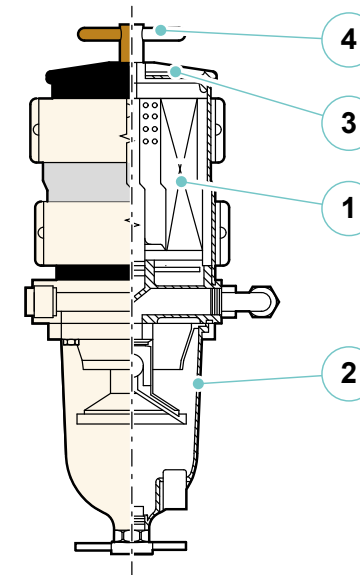

MAINTENANCE

At least once a month check the operation. At least once a week, and anyway before each refuelling, check for the presence of water in the fuel. If necessary drain the water present. When necessary, but at least once a year, replace the cartridge of the filters.

Troubleshooting procedure

The main reason for a poor start-up or lack of power is the result of a clogged filter or of an air leak in the fuel system.

If the device does not prime or does not hold the idle run, or air bubbles are visible through the check glass, first of all check the cover by means of the T-handle and vent it, if it had not been closed properly. Then check all connections and lines and make sure that no fuel line is clogged with contaminants. If the fuel tank is equipped with an incorporated filter, check for its possible clogging. If the problem persists and the filter element is new, address to Dealer.

**CAUTION**

The separators must be checked at regular intervals as suggested by the Manufacturer, in order not to impair the generators' operation.

8.9 EXHAUST SYSTEM

The engine exhausts (1) are submerged silenced exhausts. This system reduces the smoke that usually tends to soil the yacht's stern. The exhausts have to be checked at regular intervals to avoid the formation of build-ups that could prevent the correct gas ejection.



WARNING

When starting the engines, check that water comes out of the semi-submerged exhaust; this means that the engines cooling system works correctly and that the exhaust is cooled. Accelerate if no water comes out. If the problem continues, contact the Service Department.



CAUTION

A strong smell and a light smoke from exhaust insulation are normal during the first period of use.



WARNING

Avoid prolonged use of low speed engines to avoid overheating of the exhaust ducts due to reduced circulation of cooling water.

MAINTENANCE

At least once every three months carry out the tightening of the discharge raiser bolts.



**CAUTION**

Some temperature sensors have been installed on both engine exhausts, the warning lights are visible on the fly and on the engine control panels in the helm station and they light up to indicate that the temperature inside the exhausts is too high.

8.9.1 Maintenance of the engine exhausts

Component	Maintenance	Notes and precautions
Exhausts	Periodical check (as necessary, according to the floating area)	<p>Check the exhaust terminal cleanliness conditions periodically. Clean, if necessary.</p> <div style="border: 2px solid yellow; padding: 10px; text-align: center;">  <p>CAUTION</p> <p>Carbon deposits, marine growths and fouling may affect the engine regular operation, causing performance degradation and serious damages.</p> </div>

8.10 ENGINE COOLING SYSTEM

The engine and generator cooling fluid is sea water circulated by the engine inner pumps, by means of special water intake.

The sucked water flows through the strainers, is delivered to the engines, gearboxes, heat exchangers and is finally drained overboard.

In case of engine room flooding, it is possible to use this system to suck water from the bilge in large quantity proceeding as indicated at paragraph "Engines suction with bilge emergency".

When required, turn the valves completely and never to intermediate positions.



CAUTION

When the bilge is nearly dry, remember to turn the valves back to sea water intake position, in order to avoid engine damages.



WARNING

Before opening the sea cock strainer for cleaning, remember to close the cut-OFF valve in the hull.

If the yacht is not used, close as a precaution, all cut-OFF valves of the sea cocks; as soon as the yacht is reused, remember to open them.



WARNING

Avoid prolonged use of engines at low speeds to avoid overheating of the exhaust pipes due to reduced cooling water circulation.

This yacht is equipped with a Trailing Pump on the gearbox module; this system allows navigation with a single engine while safeguarding the mechanical components of the engine switched off. For long distances a “sea water” cooling circuit has been provided with the following modes of use.



For prolonged navigation with one of the two engines switched off, operate as follows:

- With both engines working, the 3-way valves, positioned between the engine and the inverter, must be kept in configuration “A” (no partialization of the water flow towards the other inverter);
- If one of the two engines shuts down or fails (engine OFF), the corresponding valve must be set to position “B” (the inverter now receives part of the cooling water from the operating gearbox flow).

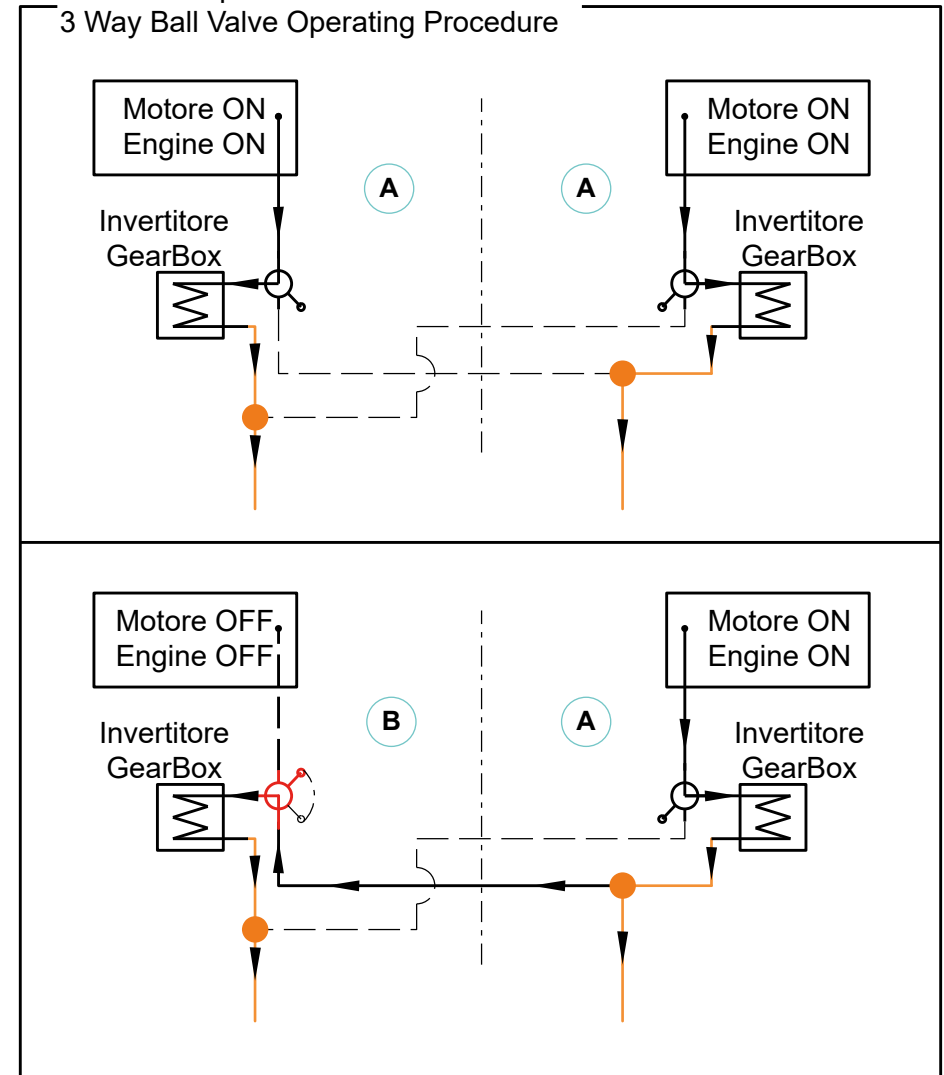
Procedura operativa valvola a sfera 3 vie
3 Way Ball Valve Operating Procedure



8.10.1 Maintenance of valves, sea cocks and strainers

Component	Maintenance	Notes and precautions
Valves, sea cocks and strainers	Cleaning (as required according to shoring area, but at least every months)	<div data-bbox="880 331 2069 703" style="border: 1px solid black; padding: 5px;"> <p style="text-align: center;">MAINTENANCE</p> <p>At least once a week check for the correct water flow through the strainers. At least once a month:</p> <ul style="list-style-type: none"> • Check the integrity of the strainers; • Check the correct operation of the sea cock valves; • Clean strainer and the suction valve. <p>At least once every six months:</p> <ul style="list-style-type: none"> • Check the condition of the cover seal; • That the valve does not show corrosion signs; • Carry out a protection treatment by means of proper products. </div> <p>Cleaning is necessary more frequently if the sucked waters are particularly dirty (seaweed, mucilage etc..).</p> <div data-bbox="880 842 2069 1038" style="border: 2px solid orange; padding: 10px; margin-top: 10px;"> <p style="text-align: center;"> WARNING</p> <p>Before removing the strainer, it is necessary to close the valve fitted to the sea cock, to prevent flooding the bilge with water.</p> </div> <div data-bbox="880 1082 2069 1378" style="border: 2px solid orange; padding: 10px; margin-top: 10px;"> <p style="text-align: center;"> WARNING</p> <p>During navigation, regularly check the cleanliness of the sea water strainer baskets. If the yacht is crossing a dirty sea area, check the condition of the strainers and proceed with their cleaning. Taking suitable precautions is very important to prevent damage to mechanical parts (engines, generators, etc..), discharge systems and to not jeopardize the safety of the yacht.</p> </div>

8.10.2 Valves, sea cocks and strainers

Inspection and cleaning

This operation has to be carried out outside, therefore the yacht must be in a dry shore or you can ask for the intervention of a diver.

- Have the sea cocks cleaned (removal of seaweed or barnacles. If necessary have them cleaned with a brush).



DANGER

If the yacht is in water, before starting to work on the shaft lines, block the start of the engines, the generators and the sea water pumps.

- Check for barnacles or corrosion on the control levers of the cut-OFF valves of the strainer to be checked.
- Clean the control levers of the valves with a brush.
- Move the levers repeatedly.
- Close the cut-OFF valve upstream the strainer.
- Remove the strainer cover by loosening the screws.
- Remove the filter element, clean it with a brush and rinse it in water.
- Clean the strainer housing.
- Check and, if necessary, replace the gasket of the strainer cover.
- Fill the strainer with water to avoid the pumps running dry or that the system does not prime.
- Reposition the strainer, the cover and tighten the nuts.
- Reopen the cut-OFF valve and check for leaks from the cover.



CAUTION

Before restarting the uses, make sure that the cut-OFF valve is completely open.



DANGER

Before working on the sea water lines, disable the operation of the connected uses.

8.11 ENGINE ROOM VENTILATION SYSTEM

The ventilation system of the engine room allows the necessary air recirculation for the operation of the propulsion systems and of the machinery installed on your yacht, in order to keep a safe temperature inside the engine room.

The ventilation system consists of two lateral air intakes (grids), which let air enter in the room and prevent the penetration of sprinkled water and of two extractors (aspirators), withdrawing the inside air and conveying it outside.

To activate the air extractors, press the magneto-thermal switch located on the main electrical panel.



CAUTION

While the engines are running, the extractors must always be activated. It is suggested to keep them on for at least 30 minutes, after anchoring, to eliminate the residual heat.



CAUTION

Do not lay tools or clothing on the extractors or on the air inlets, because the emergency closing mechanism might get blocked.



CAUTION

The engine room should be adequately ventilated when the engines or the generator are in operation and during cooling; therefore, always leave the vents open and free from obstruction.



DANGER

Carbon monoxide poisoning.

Fossil fuel combustion generates a high quantity of carbon monoxide. This gas is a colourless, odourless and highly toxic. When the engines and/or the generator are running, the yacht must be properly ventilated, in particular if underway at low speed, or when the exhaust fumes may blow back on board (e.g. when the yacht is shored or anchored or riding the anchor).



DANGER

It is strictly forbidden to insert your hands or tools inside the fan when operating or when electrically connected. Before starting the fan, make sure that this one is protected against tampering, in compliance with the laws in force.

Engine room ventilation system diagram:

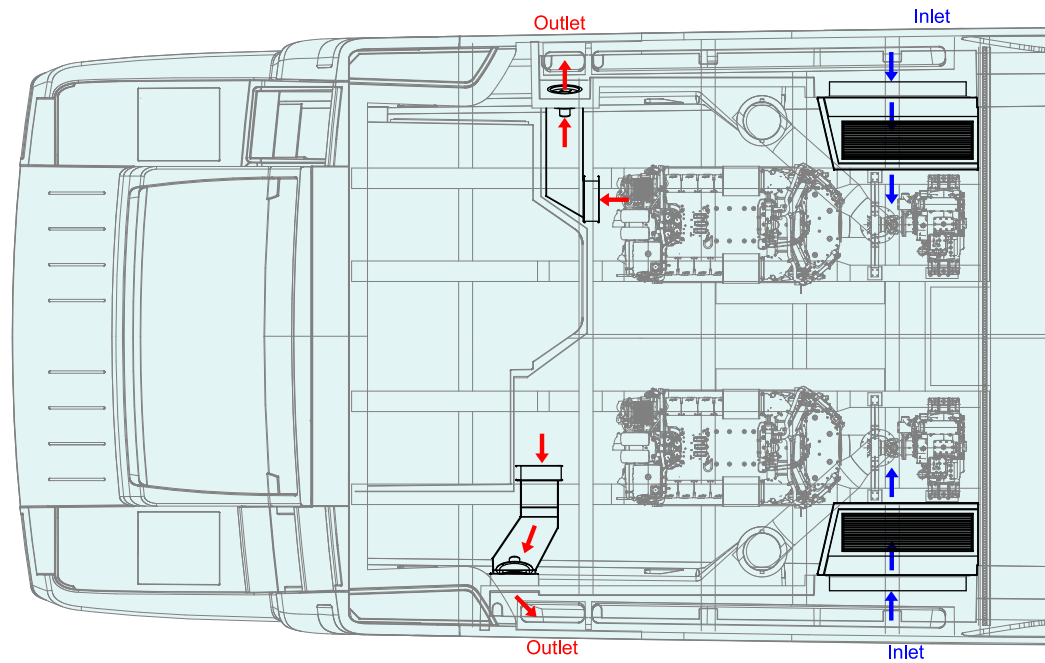
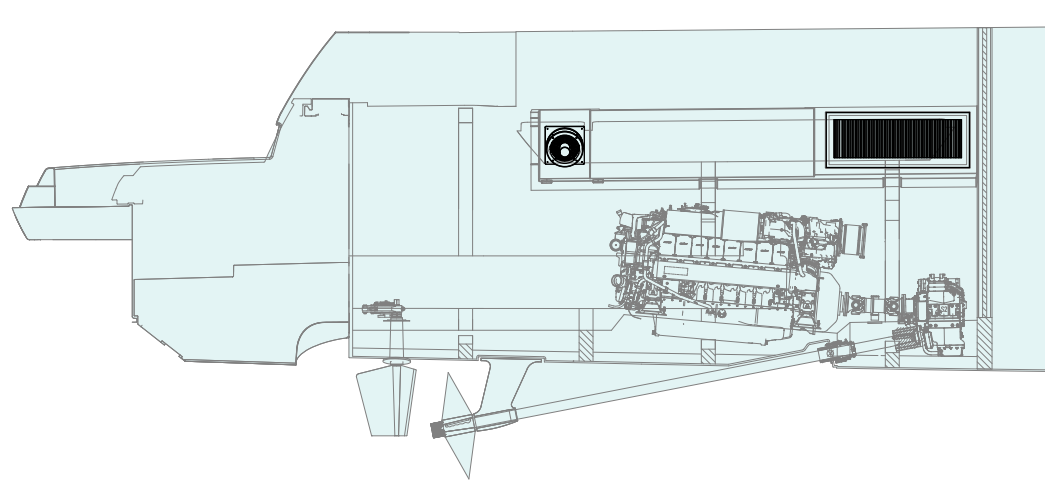

8.12 GEAR BOX

The main functions of a marine gearbox are the following:

- Couple the engine with the propeller shaft and reduce the number of revolutions of the propeller;
- Reverse the motion direction;
- Interrupt the propeller shaft motion (idle).

The gear boxes are provided with several documents.

We suggest you to read the operating instruction manual carefully and in detail.

Oil level check

Check the oil level only when the engine is OFF. The proper oil level is between the upper and the lower notch of the control rod.

After the first oil filling, a repair or the cleaning of the oil filter, the gearbox must be run for about two minutes.

Next the oil level check has to be carried out again two minutes after the engine has stopped.



CAUTION

Before starting checking the oil level, check that the gearbox oil temperature complies with the normal operating specifications.



ENVIRONMENT

Recover waste oil following the norms in force, relevant to special waste disposal.



DANGER

Service the gear box only if engine and propellers are stopped and the magneto-thermal switch is OFF. Before starting the inverter, carry out the filling and the consequent check of the oil level. The use of the gearbox with a low quantity of oil may damage the gears. An excess of oil might cause leaks to the seals and to the vent and increase remarkably the operating temperature.

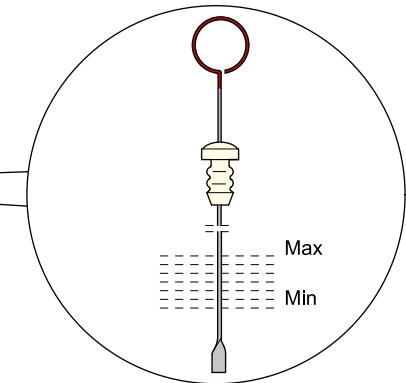

8.12.1 Gearbox maintenance

Component	Maintenance	Notes and precautions
Gearbox	Oil level check	For the correct maintenance and check procedures, refer to use manual delivered by the Manufacturer.
	Oil change	For the kind of oil and grade of viscosity recommended by the Manufacturer, refer to the gear-box plate.
	Suction filter check	Remove the plug upstream of the sump and position it near the connection area of the propeller shaft gearbox. Remove filter and seal. Replace the filter at time intervals recommended by the Manufacturer.
	Oil filter change	Have the scheduled maintenance operations performed at the correct time schedule by authorized and skilled personnel, in order to keep the gearboxes perfectly efficient.



WARNING

The gearboxes are provided with emergency controls in case of fault. Refer to the Manual delivered by the Manufacturer.



WARNING

Under normal operation conditions, the gear change can be carried out with the engine at low speed. However, in case of emergency, gear shifting can be carried out with the engine at high speed, thus remarkably reducing clutch life though.



CAUTION

The use of the gearbox with a low quantity of oil may damage the gears. An excessive quantity of oil may cause seals and vents to leak and can remarkably increase the operation temperature.

8.13 SHAFT LINE

8.13.1 Propeller shaft and through-hull seal

The propeller shaft is fastened to the gearbox by means of the flange coupling and is aligned on the three points represented by the gearbox, by a water-lubricated stuffing box seal and by the shaft support. The stuffing box case includes a piece fixed to the hull and an adjustable piece.

The adjustable piece is closed to the fixed one, in order to compress the seal, located inside the stuffing box case. It's very important that the seal disposal is compressed, in order to avoid irregular pressures on the seal seat that might compromise life and efficiency of seal disposal. The outer shaft support includes a Neoprene bushing which uses the sea water as a lubricant. Check it every season, as it might get worn quickly during cruising, especially in sandy waters. The bushing wear causes a vibrations increase. When the yacht is on a sandbank, a good technician can easily consider, by moving the shaft, if the wear demands the replacement of the bushing.



DANGER

Never approach the shafts while they are rotating.

8.13.2 Maintenance of the shaft line and of the stuffing box seal

Component	Maintenance	Notes and precautions
Shaft support bushings	Periodical checks (at least once a month) Assembly/disassembly	The Neoprene bushing of the shaft support, during navigation in waters with sandy suspensions, may wear rapidly. The bushing wear causes a vibrations increase. With the yacht in a dry shore, a good technician can easily evaluate, by moving the shaft, if the wear is so bad as to need the bushing to be replaced.
Stuffing box seal	Maintenance and check	With yacht moored at the harbor, daily and before set up navigation.
Shaft lines	Periodical checks (at least once a month)	It is essential to keep always the propellers and shafts clean; the formation of parasites or the presence of foreign bodies like cables, cloths or plastic bags lead to propulsion power reduction, to propellers cavitation with consequent surface damage, and to vibrations causing damages to the stuffing box seals and to the bushings of the shaft supports. Checking and eventual cleaning may be carried out with the yacht in a dry shore or with the help of a diver. To clean scrape the barnacles, without engraving the metal, polish them with sand paper at thin grain.

MAINTENANCE

At least once a week check for water penetration.

At least once a month carry out the cleaning.

Periodically:

- Check the status of the seals;
- Check the compression of the seal and when necessary carry out the compression;
- Check and service the cooling circuit of the seals in order to prevent dirt, seaweeds and foreign bodies from blocking the cooling water flow, thus causing the seals to overheat and, consequently, their irreparable damage.

8.13.3 Shaft support bushings

Periodical checks

Check the shaft backlash (1) trying to move the shaft on a side back and forth to verify the backlash of the shaft supporting bushing (2).

Assembly/disassembly

- If the propeller shaft (1) shows backlash, the water lubricated neoprene bushing (2) could be worn out; in this case replace it.
- Remove completely the antifouling to reveal the screwdriver screws (3) which lock the bushing positioned.
- After the propeller (4) and the shaft (1) have been disassembled, by means of a plastic tube with a slightly smaller diameter, pull out the bushing (2).

For reassembly, repeat the above-mentioned operations in reverse sequence.

- Do not use grease between propeller shaft and bushing. Remember to fasten the screws (3).

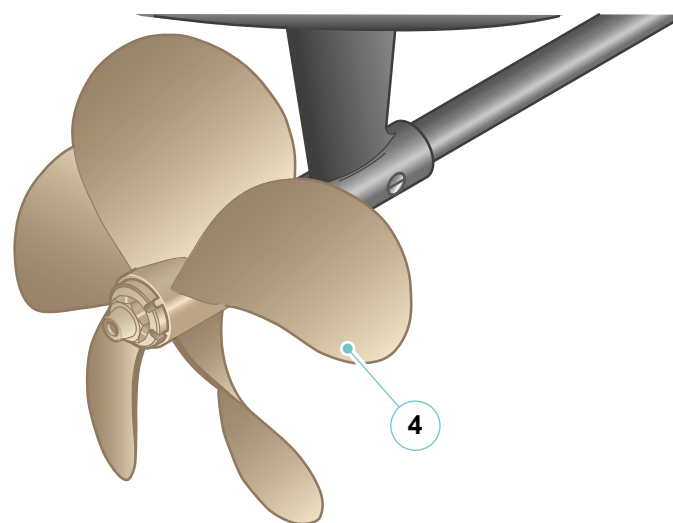
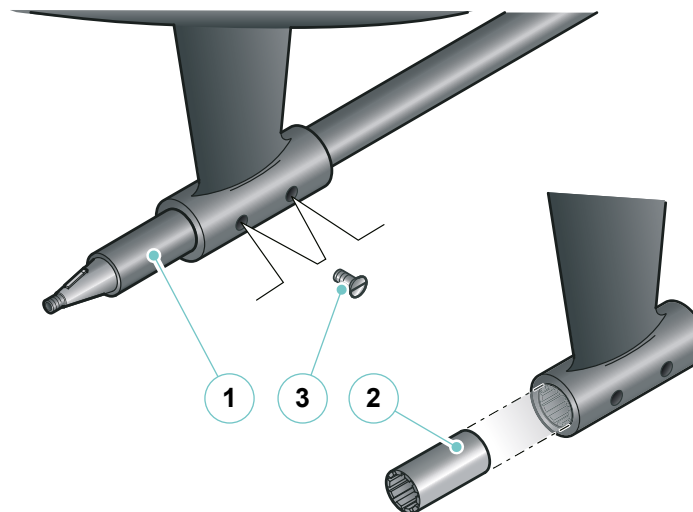

CAUTION

For spare part request contact the RIVA After Sales & Service Department.



CAUTION

Remember to tighten the fastening screws (3) of the bushing on the shaft mount. Never use grease or any other lubricant between the propeller shaft and the neoprene bushing.

8.13.4 Mechanical seal

The mechanical seal has the function of preventing sea water from entering the yacht through the space between the propeller shaft and the hull. It is made up of two sliding rings kept in contact by combined forces. One ring is defined as rotating and rotates with the shaft; the other stationary is bound to the hull.

The seal between the parts is made by means of o-rings.

Cooling of the seal is ensured by the access of water through the flushing duct.

On your yacht, between the bulkhead and the stationary element, the idrostop system can be installed (OPT).

In emergency situations and in case of water infiltration from the bulkhead, the IDROSTOP (if present) allows, once pressure has been applied, through the special pneumatic connection (max 3 bar), the return to port in complete safety, keeping the shaft stationary and at reduced speed.

Make sure before starting the engine:

- That the seal is also clean on the outside. If foreign bodies are present, it is advisable to wash thoroughly.
- That the flush water valve is open and there are no leaks from the sealing surfaces.
- Of the sacrificial anode's state of consumption.
- For medium-long periods of yacht downtime, follow the instructions in the supplier's use and maintenance manual.



CAUTION

Install the seal only when the yacht is outside the water.

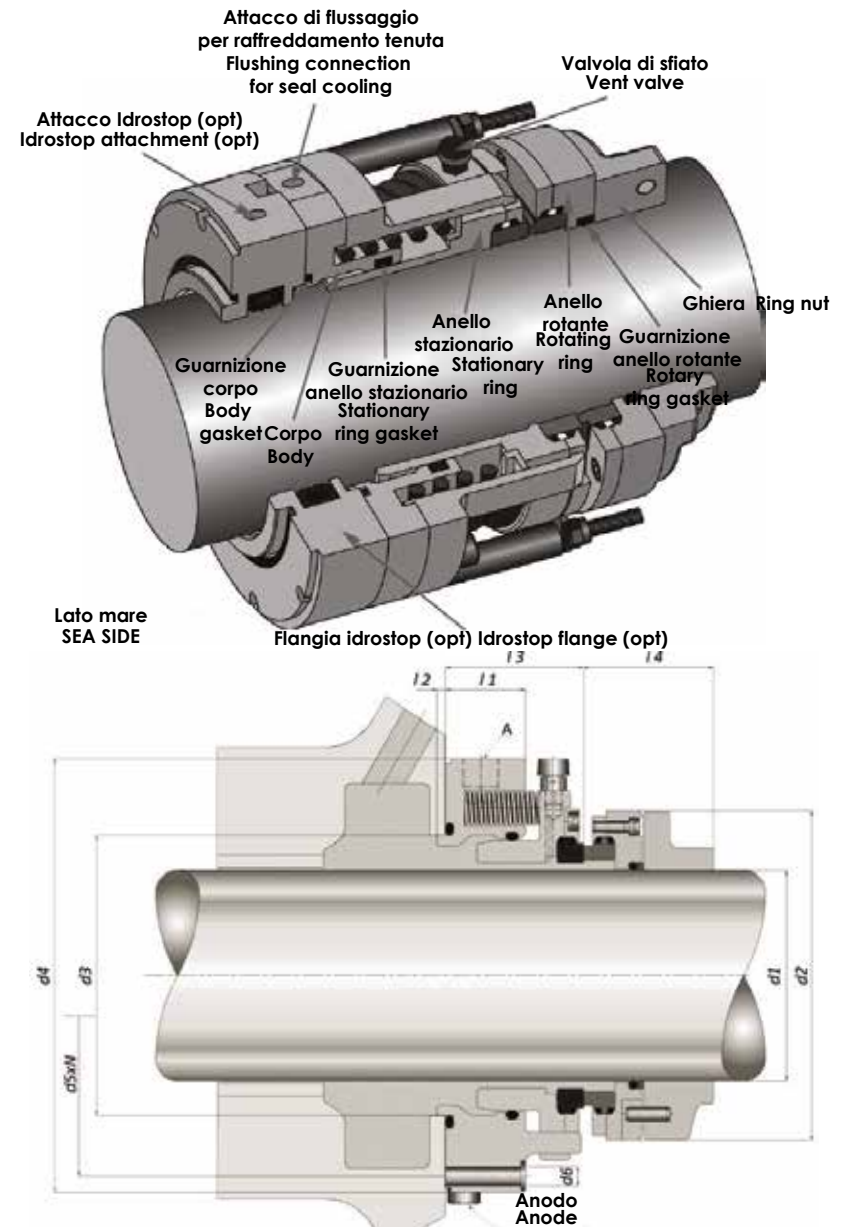

**CAUTION**

Never leave sealing surfaces in contact with substances like oil, lubricants or antifreeze.

NOTE

For further information on use and maintenance, please refer to the manufacturer's manual.

MAINTENANCE

At least once a week check for water penetration.

At least once a month carry out the cleaning. Periodically:

- Check the status of the seals;
- Check the compression of the seal and when necessary carry out the compression;
- Check and service the cooling circuit of the seals in order to prevent dirt, seaweeds and foreign bodies from blocking the cooling water flow, thus causing the seals to overheat and, consequently, their irreparable damage.

**CAUTION**

The ongoing navigation and low speed, both forward and in reverse (as in the case of fisheries), it can cause overheating of the seals and their irreparable damage.

**CAUTION**

After using the Idrostop system (OPT) you must contact the RIVA service.

8.14 PROPELLERS

The propellers (1) have been designed in order to result lightly “unloaded” with a new yacht, hull clean and without displacement overloads: in this way the engines will develop all their power in average normal operating conditions, with hulls and propellers not perfectly clean and some overloads on board.

Periodically check if the propellers are not too “dirty”, as this leads to a fast performance decrease and to a vibration increase.

In case of impact with the depth or submerged/semi-submerged bodies, check propellers and shafts immediately; in case of considerable vibrations, reduce the revolutions to the minimum and steer toward the harbor for repair, as a vibration increase might damage the propelling devices and the yacht structure.



CAUTION

RIVA yachts are designed to obtain a correct transversal trim with full optional equipment, and with spare propellers and shafts.
If the yacht is not provided with full optional and with spare propellers and shafts, some weights are inserted to correct the transversal trim.
The above-mentioned weights can be removed or displaced as soon as the yacht is provided with a new equipment.

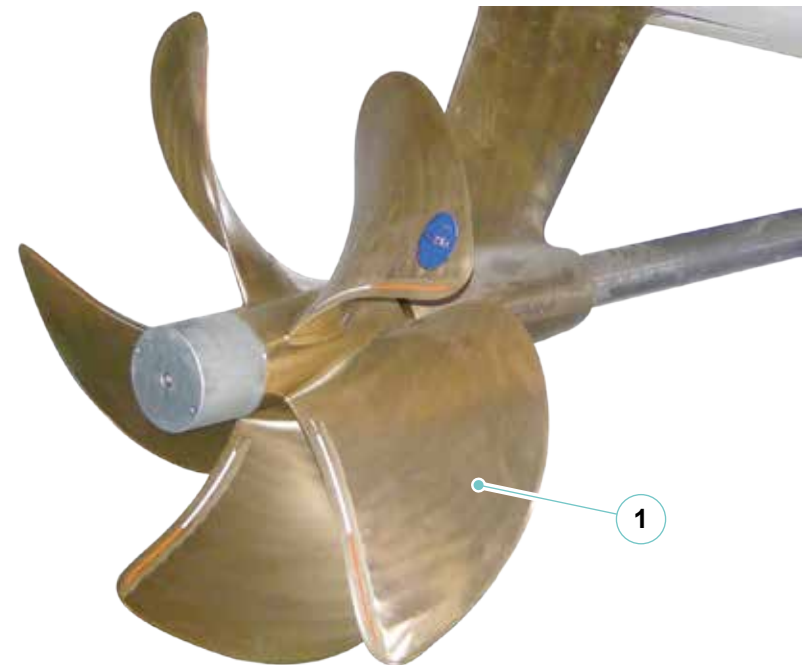
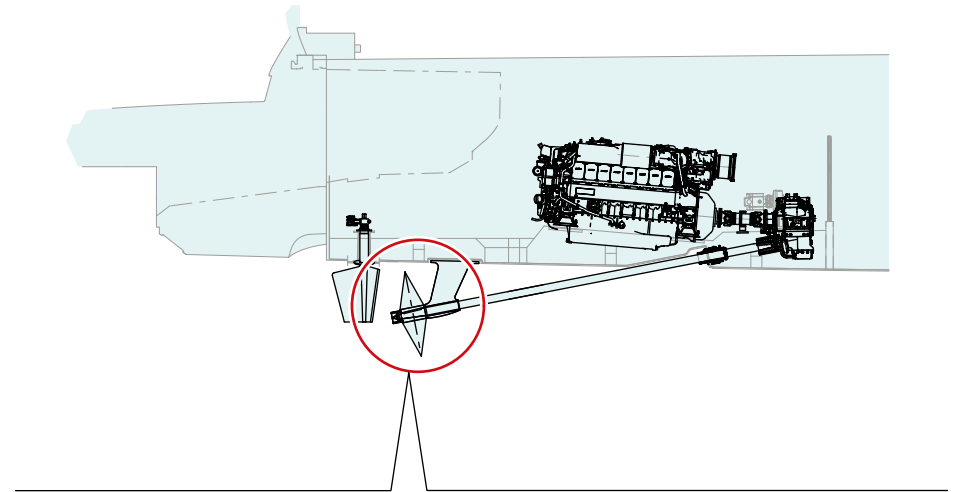

8.14.1 Maintenance of the propellers

Component	Maintenance	Notes and precautions
Propellers	Periodical checks	<p>The propeller check should be performed according to the floating waters. Inspection and possible cleaning may be carried out with the yacht in a dry shore or with the help of a diver.</p> <p>Check if the propeller blades have notches, fractures, fouling or barnacles which may have a negative influence on the yacht performances during navigation.</p> <p>If you notice corrosion, check the anodes conditions and replace the propellers for major failures.</p>
	Assembly/disassembly	<p>The starboard and port propeller are not interchangeable between them neither with others as designed according to specific features of your yacht.</p> <p>Replace only with genuine spare parts supplied by the RIVA After Sales & Service Department.</p>

8.14.2 Periodical checks of propellers



DANGER

To clean and check the yacht in water: disable the engines and generators start.

It is advisable to carry out this operation by yacht in dry shore because maintenance is in this way eased. Check if the propeller paddles show notches or breaks, scales or barnacles, which may have a negative influence on the yacht output during navigation. If you notice corrosion, check the anodes conditions and replace the propellers for major failures.

Propellers assembly/disassembly

The propellers (starboard and port) are not interchangeable between them; they are bronze meltings according to specific features of your yacht. The extreme end of the shaft (9) is conical and a little key allows the coupling with the propeller (5) which must be inserted up to the shaft catch and leaving the propeller stretching out from the shaft plane of 2÷3 mm.



CAUTION

Do not replace the propellers of your yacht with other of doubtful origin. Contact the RIVA After Sales & Service Department. Each yacht model has its own propeller

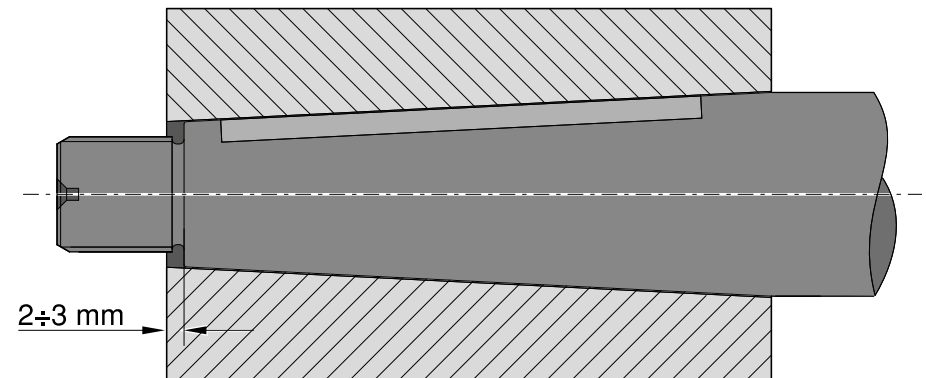

Pieces should not show burrs or dents to make the coupling effective. It is essential to lubricate them with plenty of silicon grease.

Tighten the nut (4) locking the propeller on the shaft (9); on the propeller hub there are three holes to 120°. Tighten as necessary to insert the dowel (3), to avoid natural loosening.

For disassembly keep an extractor at disposal so as not to deform the propeller.

In case of obstacles or excessive sticking, heat the propeller to expand the coupling and ease the removal.



CAUTION

Avoid the use of hammers or mallets to pull out the propeller. The pull out force must be uniformly exerted on the entire hub of the propellers.

Hereunder a list of the components of shafts and propellers line:

1. Screw
2. Propeller anode
3. Dowel
4. Nut
5. Propeller
6. Shaft support bushing
7. Shaft support
8. Countersunk screws with notch
9. Propeller shaft

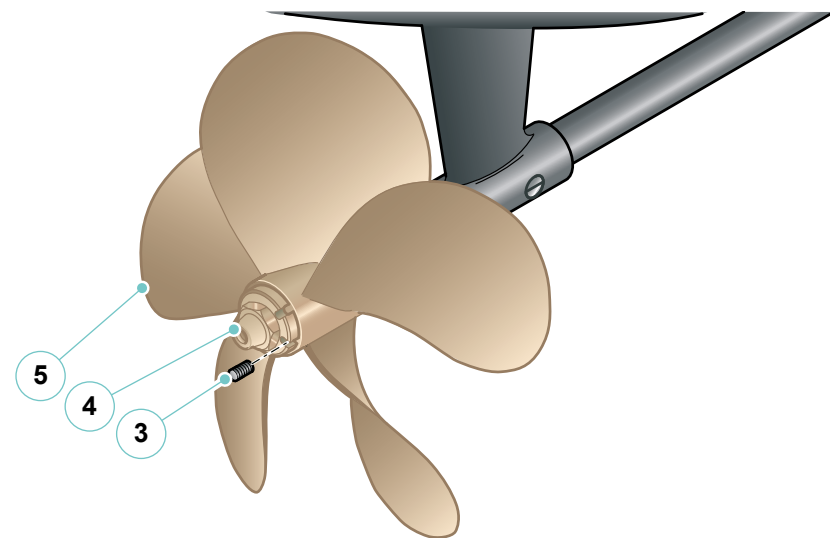
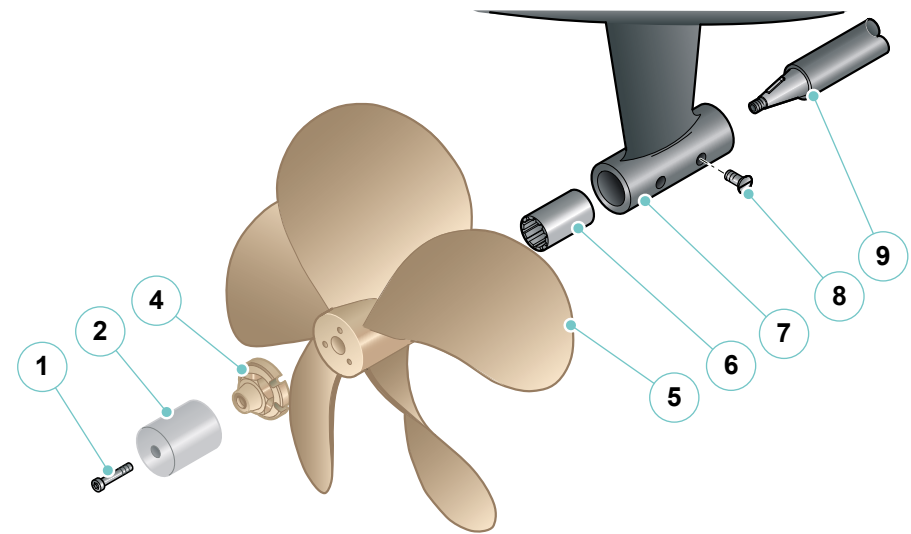

Riva

102 CORSARO *supera*

STEERING SYSTEM

CHAPTER 9

9.1 STEERING SYSTEM

The electro-hydraulic steering system contributes to a good maneuverability of the yacht. When the steering wheel in the helm station is turned, a hydraulic pump is operated to activate the piston located in the engine room and connected directly to the rudders, thus maneuvering the yacht.

The transfer of the steering control to a secondary control station takes place with the following procedure: require the transfer from the station in operation which will remain active until the consent is given from the receiving station.

The mutual transfer between the different stations can only take place in the absence of propulsion (engines in neutral position).

The steering of a rudder is always guaranteed in case of main electronic system failure by a backup panel.

A rudder that cannot be electrically operated can always be released with the power pack by-pass and will be free to move.

1. Pneumatic cylinder
2. Rudder bar
3. Electro-hydraulic power pack

NOTE

For further information on use and maintenance, please refer to the manufacturer's manual.

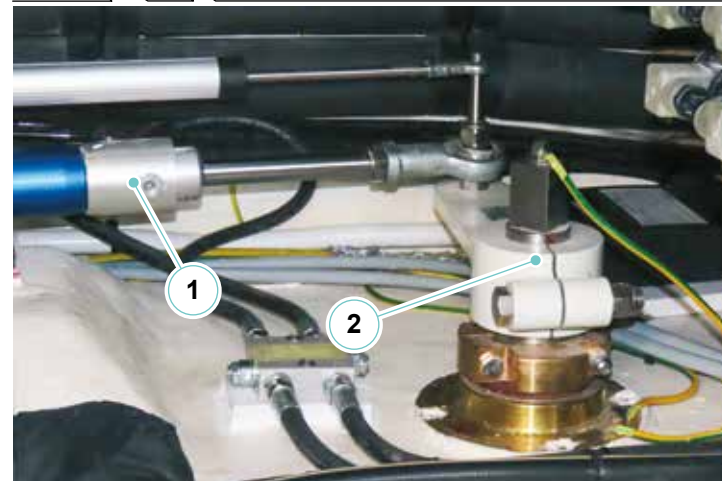

Steering system scheme:

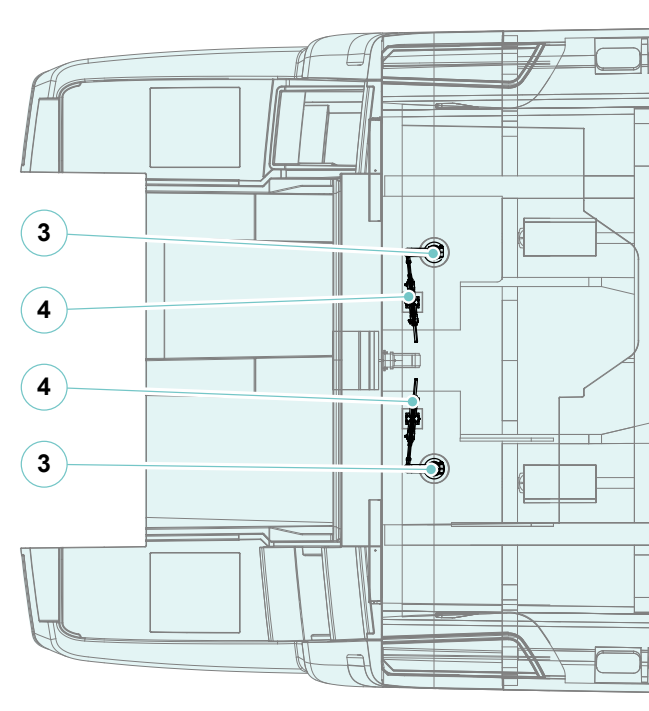
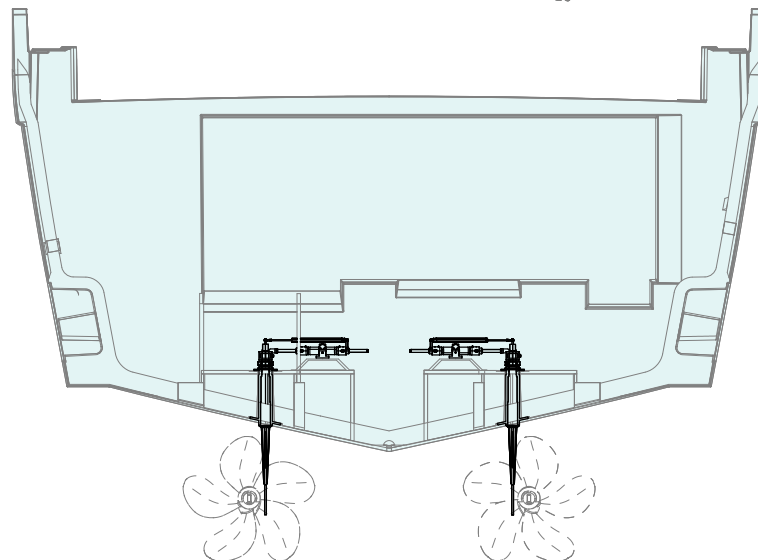
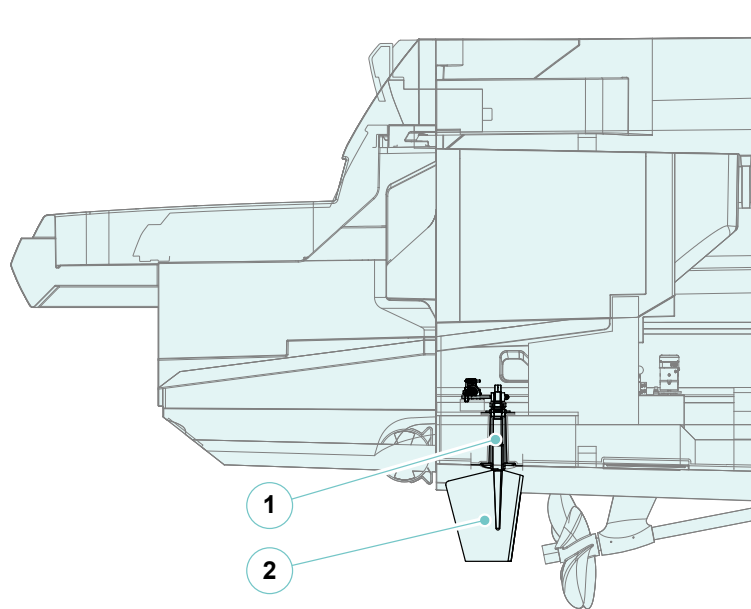

ICONA ICON	DESCRIZIONE DESCRIPTION
1	Foro timone Rudder hole
2	Timone Rudder
3	Barra del timone Rudder bar
4	Timoneria idraulica Hydraulic steering

9.2 INTERCEPTORS SYSTEM

The yacht is equipped with two interceptors, which can be controlled from the control post. Each interceptor is driven by an electric motor. They allow you to vary both the yacht's longitudinal and transverse trim during navigation.

Familiarisation with the use of interceptors is important, as their correct use will improve performance and comfort.

In principle, lowering and raising the interceptors will lower and raise the bow of the yacht respectively.

Correct positioning of the interceptors results in a stable and ideal setup which can increase speed while reducing consumption.

In particular navigation conditions, when, due to lateral forces of the sea, sea currents and wind, the yacht assumes an inclined attitude, to restore normal conditions while maintaining the course, it is necessary to act on the wheel of the rudder or with the offset use of the interceptors.



WARNING

Interceptors are normally used during cruising, both to make it more comfortable and to achieve better performance of the yacht, according to the sea and navigation condition, and the yacht loading.



CAUTION

When using reverse, set the interceptors fully up otherwise they may be damaged.

A signal sent from the bridge to the electronic control unit located in the engine room activates the interceptor drive motor. The motor rotates in the chosen direction and determines the interceptor inclination.

Pressing the button on the other position determines the opposite movement of the motor. Each button controls the movement of an interceptor.

The monitoring system provides a reading of the interceptor outflow, measured by means of a position transducer placed on each of them.

Some suggestions will be useful in familiarizing yourself with the interceptors:

- After the yacht has moved to the glide position, adjust the position of the interceptors to find the angle most favourable to navigation;
- At high speeds, it is recommended not to operate the interceptors at the same time, one "up" and the other "down", but to carry out the operations separately in order to avoid abrupt swerving; instead, it is possible to operate them simultaneously in the same direction;
- In calm seas, the best position for interceptors is to allow maximum speed with less yacht drag;
- In rough "bow" sea, the "down" interceptors will allow you to "beat less" and navigate with more comfort even if your speed will be reduced;
- In rough seas "on the stern", the interceptors "up" will tend to raise the bow thus avoiding unpleasant;
- With lateral wave motion or asymmetrical lateral load, the best stability is achieved with staggered interceptors;
- If the yacht is not in motion, place the interceptors all on.

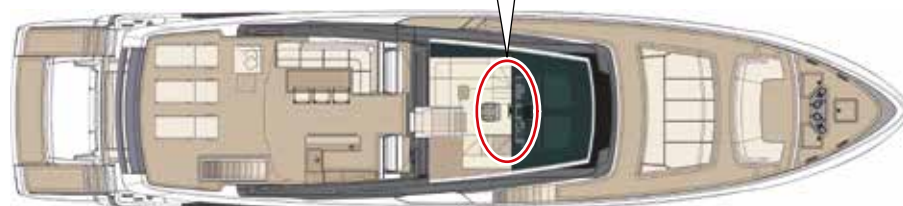
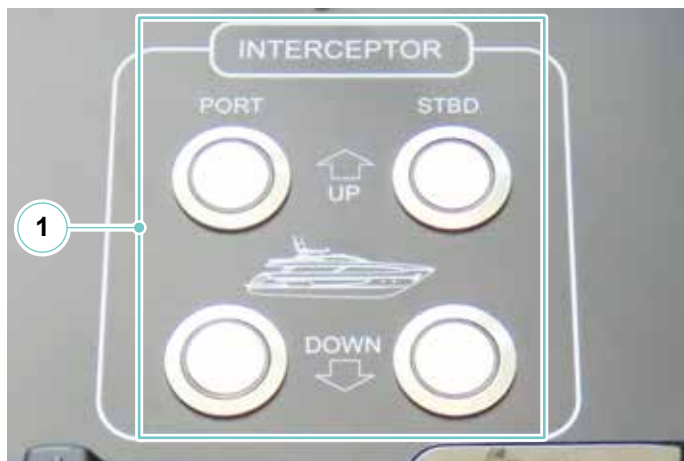

1. Helm station control panel
2. Interceptors

**CAUTION**

The manual use of interceptor (“trim assist” function disabled or override), running at high speed, requires special attention and it is normally not recommended.

**CAUTION**

The interceptors, as well as transmission systems, can give sudden changes of direction to the yacht if they are operated too quickly or at large angles, especially as speed increases and during manoeuvres (since they are sized and optimised for intermediate speeds).

**CAUTION**

As is good practice on a yacht, always make sure that passengers are seated before performing large adjustment manoeuvres on the interceptors, especially if you are navigating at high speed.

**CAUTION**

Periodically clean interceptors to remove any corrosion that may affect their efficiency. To reduce the risk of corrosion, retract the cylinder rods especially when the yacht is stopped for some time in the shore or on the ground.

NOTE

For further information on use and maintenance, please refer to the manufacturer’s manual.

9.2.1 Interceptors system maintenance

Component	Maintenance	Notes and precautions
Sacrificial anodes	Check and replacement	Check the two anodes installed to protect the interceptors at least once a month and replace them when necessary.

MAINTENANCE

At least once a month, and in any case before each sea trip, check the functioning of the interceptors.

At least once every 3 months:

- Check the status of the anodes and, when necessary, replace them;
- Check the condition of the antifouling, restore when necessary.

At least once every 6 months protect the motors and fittings with special products.

At least once a year, use antifouling protection.

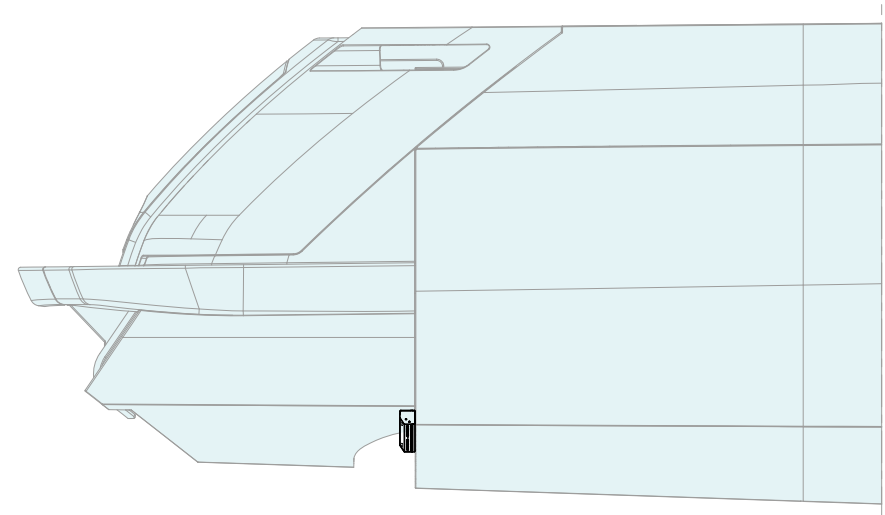
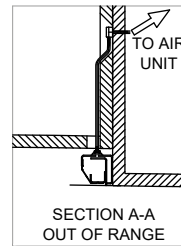
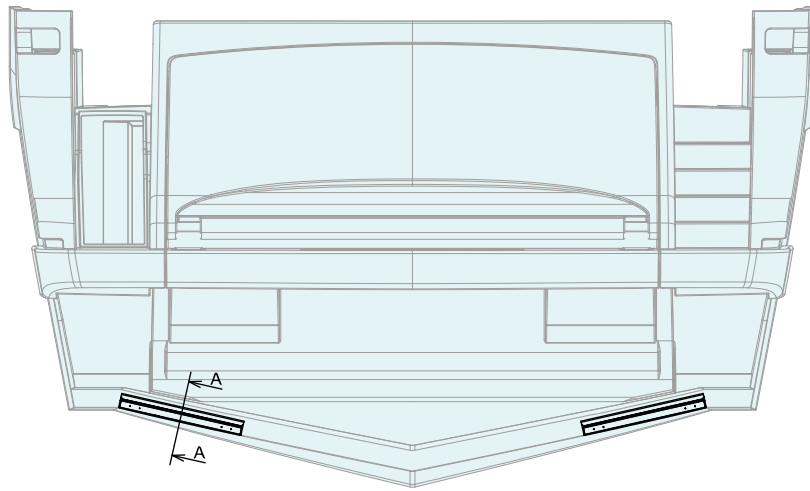

9.3 BOW AND STERN THRUSTERS

The thruster is a very simple and robust accessory, but it requires some attention:

- The thruster must be used at a very low speed, or without fresh way; at higher speed, more correct reactions can be obtained with the offset use of the gear boxes;
- Each time the yacht is lifted up, check the condition of each thruster, of the protection anodes and of the fastening system.

MAINTENANCE

At least once a week check the correct operation.
At least once every three months check the status of the sacrificial anodes and if necessary, replace them.
When necessary fill oil.

NOTE

For further information on use and maintenance, please refer to the manufacturer's manual.

Use of the operating thruster

Enable the relevant controls via the monitoring system and press the ON button on the joystick of the chosen control panel (bridge, fly bridge or third station). A continuously on indicator light confirms readiness for use. The thrusters are controlled via the control joysticks.



WARNING

When the thruster is no longer in use, press the OFF button on the control panel.



CAUTION

In case it is necessary to replace a fuse on the thruster system, have this operation carried out by a skilled naval electrician.
Take care to carry out a preliminary inspection of the relevant documents or to contact the Service Department.



WARNING

On the synoptic panel in the control panel there is a light that, if on, indicates that the operating thruster is powered.



CAUTION

For the continuous operation of the thruster, refer to the manual delivered by the Manufacturer.



CAUTION

When the bow thruster is not used, always disconnect the control unit.



DANGER

During the thruster operation, pay attention to possible swimmers or small boats which may be close to the thruster openings.
Do not test the thruster when the yacht is outside water, unless you are sure the workers are at safety distance from the thruster tunnel.



DANGER

Always stop the thruster before undertaking inspection or maintenance tasks by disconnecting the switches and possibly also the battery terminals.



CAUTION

Never activate the thruster for more than one second when the yacht is at dry shore, as this can seriously damage the system.

1. Bow thruster
2. Bow thruster control joystick
3. Bow thruster motor
4. Stern thruster control joystick
5. Stern thruster

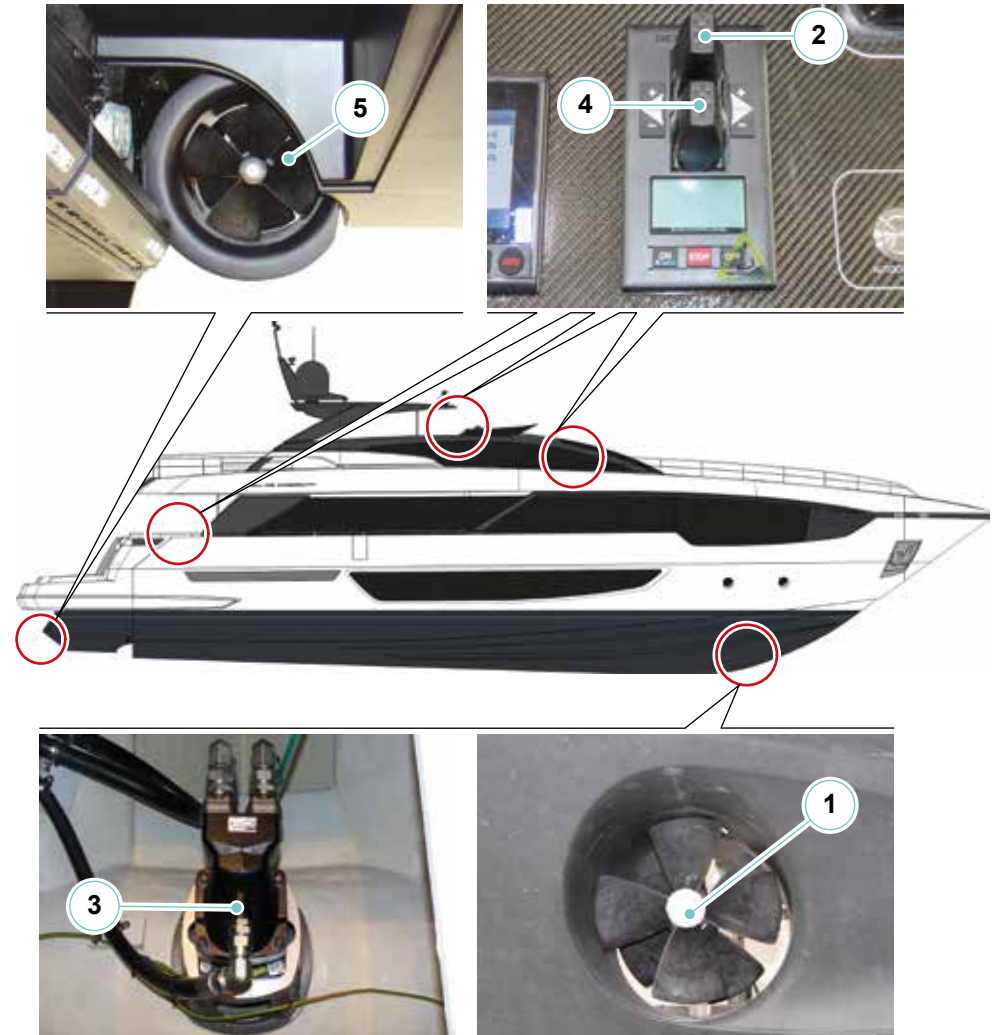

9.4 STABILIZING FINS SYSTEM

The fins are of airfoils to all effects and exploit the water speed which meet to create lift on the upper or lower surface, depending on how the fins are rotated with respect to their axis.

So, according to their imposed by the control logic, they, by means of hydraulic actuators, they move in such a way as to give an immediate response to the action of rolling.

The greater the speed of the hull, the greater will be the lift that the fins will create and that they will influence ship stops practically nothing.

The control system includes an electronic control unit.

Leaving the harbour, just activate the system, which in a totally autonomous manner manages the trim of the yacht in a continuous and effective way, thanks to the stabilizing fins mounted under the hull.

The system adapts its interventions in function of speed, the state of the sea and of the direction of the waves, and of course the heeling data coming from the sensors.

The stabilizing fins of the system are equipped with very strong electromechanical mechanisms that ensure effective durability.

On this yacht it is also present the Zero Speed system that allows the operation of the stabilizing fins even with the engines OFF.



CAUTION

Fins in Zero Speed mode must not be activated with people swimming around the yacht.

NOTE

For further information on use and maintenance, please refer to the manufacturer's manual.



CAUTION

The power of the stabilizing fins panel must always be maintained on the main electrical panel, also in case of non-use of the system stabilizing fins, the fins must be kept at the center.

9.4.1 Hydraulic system for stabilizing fins and bow/stern thrusters

This is an independent system operating by means of two hydraulic pumps (each one fitted on a gear box), which suck oil from a suitable tank and convey it to a control valve.

From the control valve depart two lines: one supplies the stabilizing fins group, the other the bow thruster. In the stabilizing fins assembly, the oil flows out of the control valve and reaches two separated blocks of solenoid valves, each of which drives the hydraulic cylinders of each fins. In the other line of the bow thruster, oil supplies a further block of solenoid valves, that activates the hydraulic motor on which the bow thruster is fastened.

A heat exchanger is connected to the hydraulic tank, which uses sea water to cool down the oil, in order to keep oil temperature constant, a pressure gauge, to keep the oil pressure under control, and a visual gauge to monitor the level.

NOTE

For further information on use and maintenance, please refer to the manufacturer's manual.

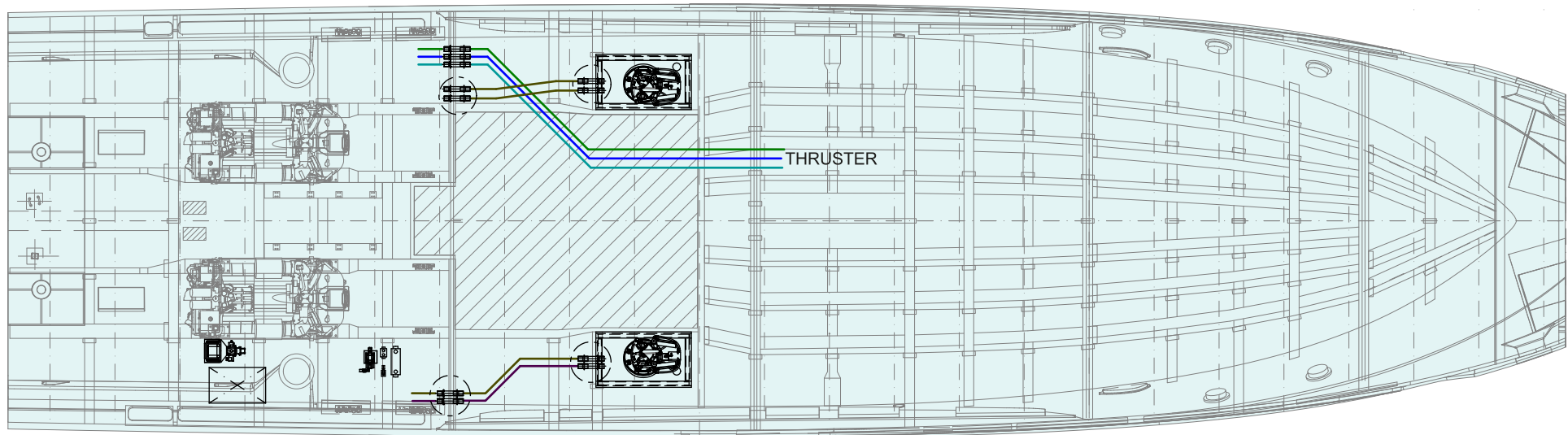

9.5 GYROSCOPIC STABILIZER (OPTIONAL)

To reduce the annoying effect of the wave-induced rolling motion, a system has been installed comprising a gyroscopic stabilizer capable of generating a rotation equal and opposite to that of the waves. The system provides a remarkable reduction of the pitch both with the yacht stationary or during navigation with low energy consumption that does not impair the quality of life on board and does not affect performance.

Thanks to these important features, the device can also be kept on at night to allow a greater comfort by damping almost completely the annoying rolling motion.

The stabilizer devices are based on a well-known principle of physics: a gyroscope tends to maintain its vertical rotation axis, parallel to the acceleration of gravity.

When an external force attempts to vary the position of the stabilizer, such as roll caused by the movement of waves, the stabilizer prevents this action by rotating along an axis perpendicular to its own and that of the disruptive cause.

This generated operation (pitch) is reduced by means of two dampeners, duly calibrated according to yacht's features.

The system consists of one or two stabilisers positioned centrally in the engine room and a control display on the bridge control panel.

NOTE

For further information on use and maintenance, please refer to the manufacturer's manual.

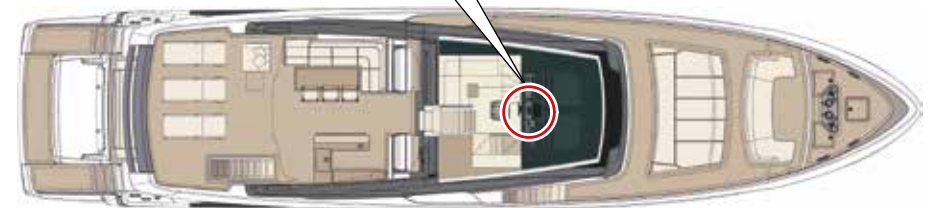

**CAUTION**

Have the scheduled PERIODIC INSPECTION performed by skilled personnel every two years. Address to RIVA After Sales & Service Department for further information.

**WARNING**

During operation, the stabilizers, vibration dampers and their housing overheat. Touching the stabilizers during operation may cause burns.

**DANGER**

The stabilizer housing is not a solid component. If you place objects or sit on the stabilizer, the stabilizer may become damaged.

**CAUTION**

The stabilizer is not watertight. If it's submerged in seawater, it could be damaged.

MAINTENANCE

The gyroscope system is designed to require as little maintenance as possible. However, since the system is equipped with mechanical and electrical components for operation at sea, periodic checks and maintenance are recommended. The manufacturer recommends an annual inspection and maintenance interval every 2000 hours of operation of the gyroscope in the absence of failure.

Riva

102 CORSARO *supera*

AIR CONDITIONING SYSTEM

CHAPTER 10

10.1 AIR CONDITIONING SYSTEM

The air conditioning system consists of a conditioning unit with heat pump equipped with inner heat exchanger that cools (or heats in winter) the fresh water of a closed circuit. This unit is used to cool water used as a thermal exchange with the air of the rooms to be cooled down.

In winter the inversion of the cooling circuit (by heat pump) allows the water heating instead of the cooling, in this way the rooms get warmed up.

The fresh water, by means of a circulation pump, delivers cooled (or heated) water to the fan-coils until it reaches the set temperature.



WARNING

Check that fresh water circulates regularly. Because of a pressure drops or of a long period of inactivity, stop the system and top up water through supply valve until the requested pressure is achieved, this will be indicated by proper pressure switch installed on the unit. After this, close the supply valve.

The entire system is powered by 120/240VAC, and is controlled by a magneto-thermal on the main electrical panel in the engine room. The compressor unit is located in the engine room under the garage.

Each conditioned room is equipped with self-adjusting control panel.



CAUTION

Two magneto-thermal switches for AIR CONDITIONING and FAN COIL BLOWERS are installed on the main electrical panel, both switches must be set to ON, in order to operate the air conditioning system correctly.

For operation and maintenance descriptions and information, please refer to the relevant Manufacturer's Manual.

Before starting the system, check the free rotation of the sea water pump and the circulation pump.

Rotation should be free, in case the pump is locked, do not start, but eliminate troubles first (dirt, rust, scraps, etc..).

Check that the sea water inlet and outlet valves are both open. Power the chiller using the selector located on the separate electrical panel.

It is advisable to check the power absorbed by the pumps and to compare it with the plate data.

The unit will work normally if the circulation of sea water and treated water is correct. After a few seconds the compressor will start.

Its operation will stop when reaching the temperature of chilled water 7 to 8°C. The temperature of the chilled water can be checked by suitable thermometers placed on the unit. The cooled water temperature can be set by means of the thermostat on the unit's control panel. The chilled water circulation pump will circulate water to the different fan-coils. Fancoils will exchange heat with surrounding ambient, the return water will be heated and the thermostat will automatically start the compressor, in a differential range of 3 to 4°C, thus keeping the chilled water temperature in the range from 7 to 11°C.

**CAUTION**

Clean the strainer of the sea cock according to the time interval of the system use and to the pollution conditions of the sucked waters (seaweeds, mucilage's, etc..).

**CAUTION**

Before cleaning the strainer, remember to close the sea cock valve, to stop the generator and then proceed with maintenance. Once this operation is finished, remember to open the valve which supplies the cooling circuit.

**CAUTION**

When the yacht is connected to the shore socket, due to the limited power that can be drawn from the 200 V-50 A socket (equal to 10 kVA), it is necessary to limit the maximum power absorbed by the A/C unit, excluding at least one of the three compressors; this is to prevent the thermal protection from tripping.

NOTE

For further information on use and maintenance, please refer to the manufacturer's manual.

**CAUTION**

When starting the unit after a prolonged shut down check the correct operation of the sea water pump and make sure of proper circulation.

**CAUTION**

The excessive use of conditioned air may cause infirmities due to the great difference of temperature between the yacht inside and the outside.

**CAUTION**

Never clog the temperature sensors located in each air conditioned room; as their clogging could impair the correct operation of the system.

Air conditioning system diagram:

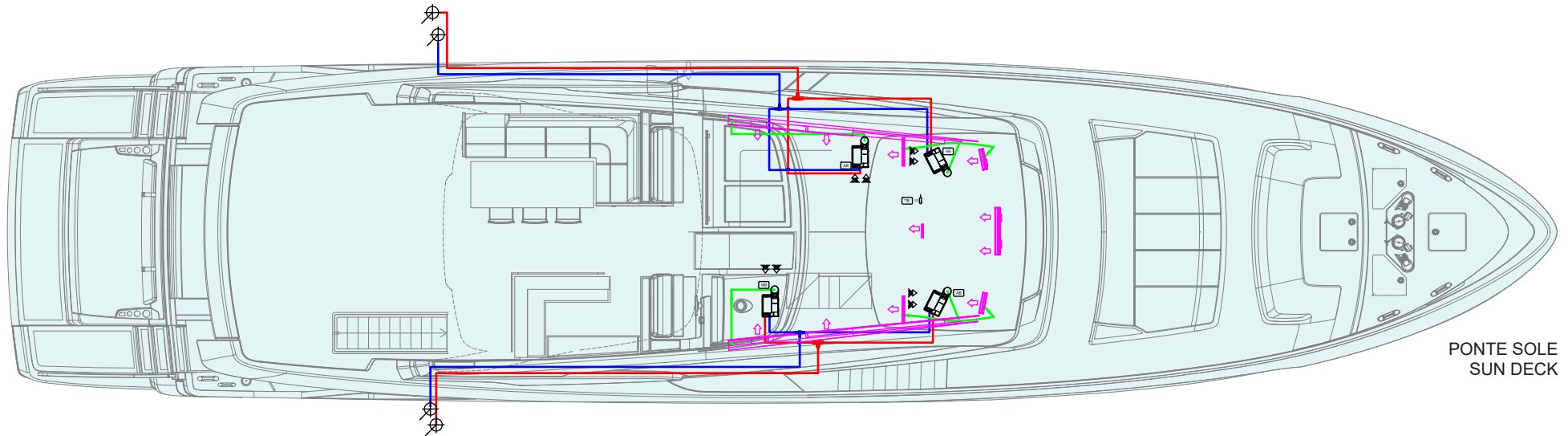

PONTE SOLE
SUN DECK

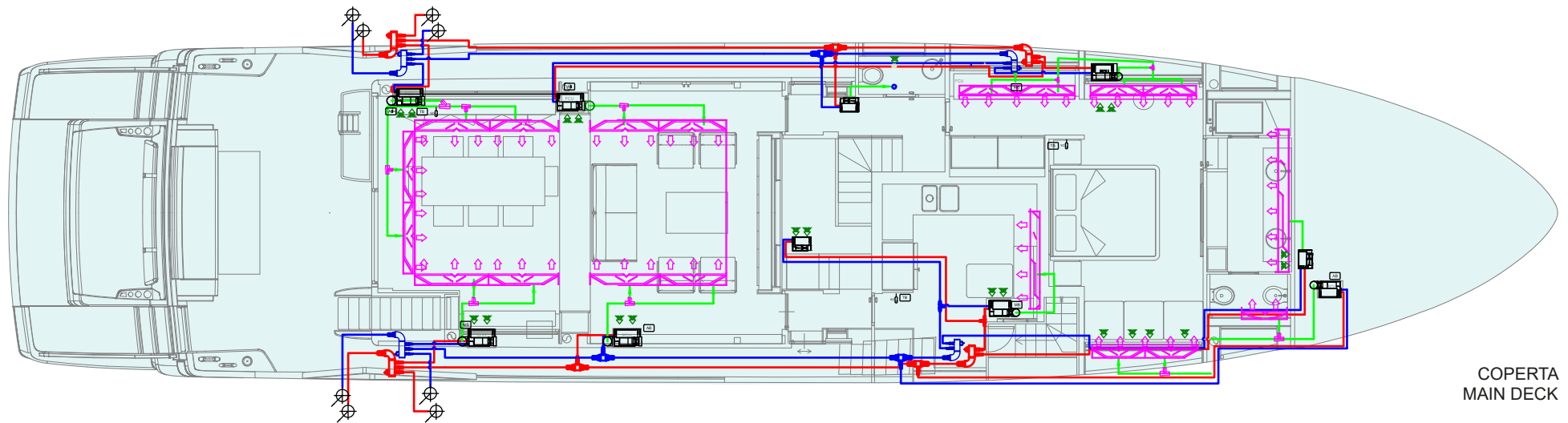

COPERTA
MAIN DECK

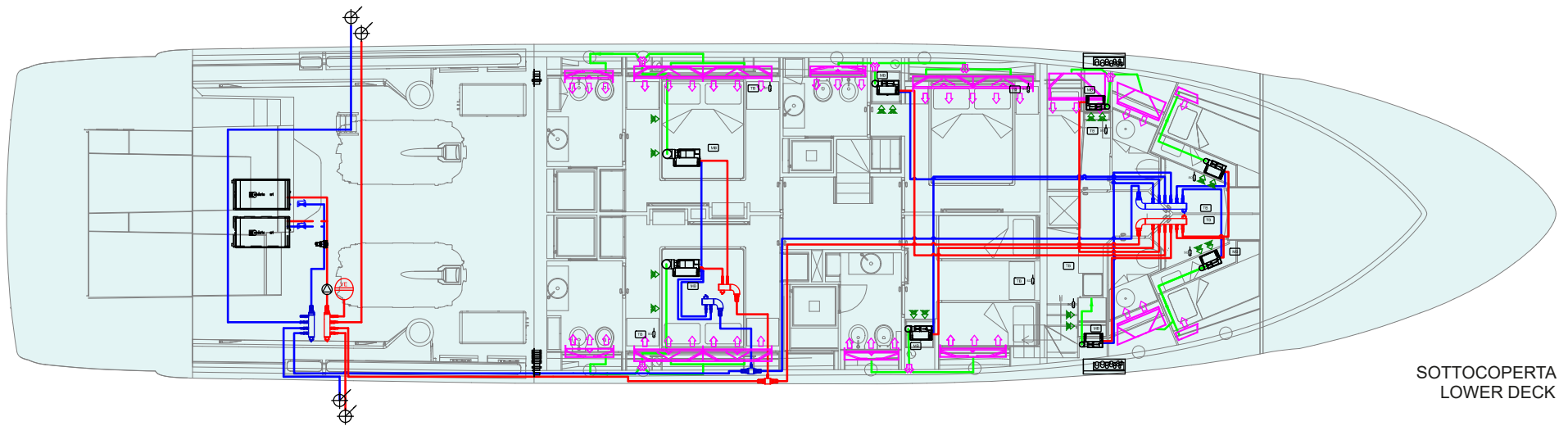

SOTTOCOPERTA
LOWER DECK

ICONA ICON	DESCRIZIONE DESCRIPTION
	Al ponte superiore To the upper deck
	Al ponte inferiore To the lower deck
	Fan coil Fan coil
	Ripresa aria Air intake
	Mandata aria Air outlet
	Griglia aspirazione/mandata Intake/outlet grid

ICONA ICON	DESCRIZIONE DESCRIPTION
	Sonda temperatura Temperature probe
	Cassetta raccolta condensa Condensation collection box
	Pannello regolazione ambiente Room control panel
	Scheda master Master board
	Scheda fan coil ausiliari Auxiliary fan coil board
	Raccordo a T TEE

ICONA ICON	DESCRIZIONE DESCRIPTION
	Disaeratore Deaerator
	Mandata fan coil FCU outlet
	Ripresa aria Air intake
	Linea mandata acqua Water delivery line
	Linea ritorno acqua Water return line

10.1.1 Refrigerating unit control panel

The control panels of the cooling system located in the engine room and in the main helm station have the following functions:

1. **Alarm indicator**
If pressed, the button shows the active alarms on the display.
2. **Program mode**
Press to enter the menu.
3. **Escape to exit**
Press to exit the menu.
4. **Scroll up**
Press to scroll up.
5. **Enter**
Press to select and confirm the highlighted option.
6. **Scroll down**
Press to scroll down.
7. **Display**

At first start the chiller unit will operate according to the parameters set.

NOTE

For further information on use and maintenance, please refer to the manufacturer's manual.



CAUTION

It is strongly recommended that the factory-settings NOT BE CHANGED. This is possible only in exceptional cases and with the help of RIVA staff and After Sales & Service Department.



CAUTION

The signal of any alarm implies a failure in the operation of the system. INVESTIGATE and ELIMINATE THE REASON FOR THE FAULTY OPERATION before restarting the system. Refer to the specific manual or refer to the RIVA After Sales & Service Department.

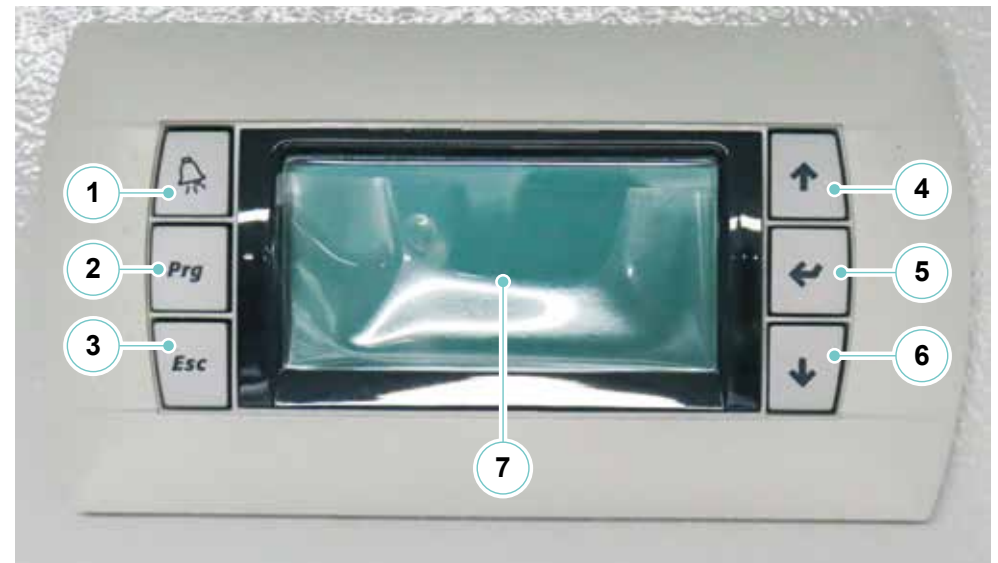

10.1.2 Fan-coil control panel

The fan-coil control panel, located in each room as per the air conditioning control diagram, has the following functions:

1. Ambient temperature detected
2. Mode of operation
 - Heating
 - Electric Heating
 - Cooling
 - Fan only
3. Fan speed

Pressing on the symbol opens the operation selection menu.

 - Automatic
 - Manual
4. Fan-coil shutdown
5. Temperature reached

Pressing on the symbol opens the operation selection menu:

 - Cooling
 - Heating
 - Electric Heating
 - Fan only
6. Temperature setting keys.
7. Configuration key

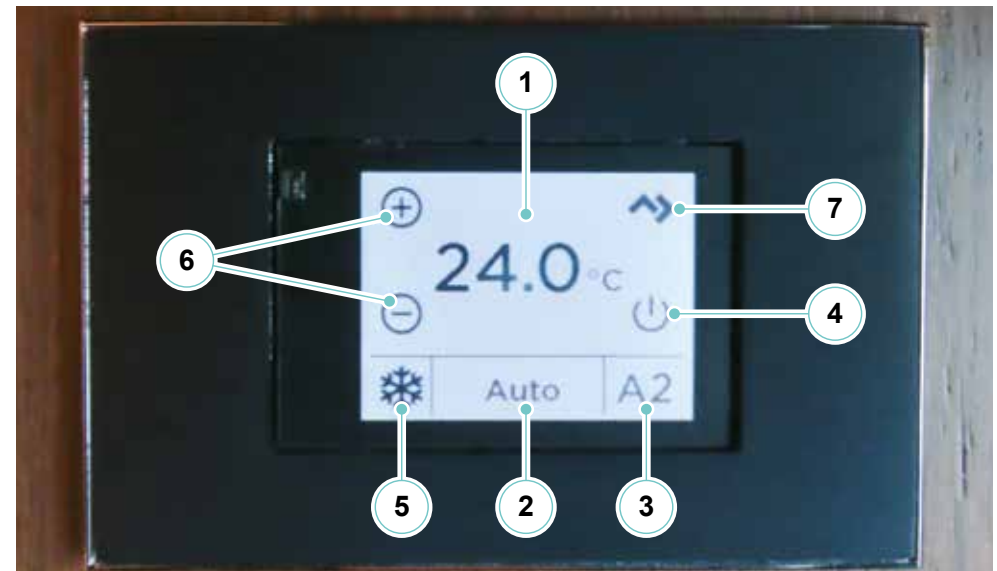

NOTE

For further information on use and maintenance, please refer to the manufacturer's manual.

10.1.3 Air conditioning system maintenance

No delivery of cool or warm air from fan-coils

Lack of treated water in pipes. Check if the pressure gauge operates at the minimum pressure of 10 m with idle system. In case the gauge reads 0, most probably there are air pockets in the circuit or water leaks. Stop the system and fill water through a cock so as to reach a pressure of 10- 15 m. Bleed air by means of the relevant valves installed on the heat exchanger, the fan-coils and the manifolds, keep the bleed valve open. If the treated water flows regularly, and the outlet does not release warm or cold air, check if the fan turns and if the room thermostat is set to correct summer-winter position.

Fan-coils air setting

Each fan-coil allows setting three speeds and an automatic speed. Select the required mode.

Room temperature setting

To obtain the desired room temperature, set the thermostat to +21, +22°C / +70, +72°F in winter cycle and to +24, +25°C / +75, +77°F in summer cycle. Refer to the instruction manual.

Temperature check of treated water in the fan-coils circuit

The treated water temperature check is performed through two digital control panels. The water temperature inside the fan-coil circuit may vary from 0 °C/32°F +60°C/+140°F and by exactly the water temperature in the fan-coil circuit.

For a good BTU/h performance, the thermometer should indicate +7 + 8 °C/+45, +46°F in summer and +45°C/+113°F in winter after 15-20 minutes of operation.

When the set temperature is reached, the compressor stops, while the treated water pump keeps running.

The compressor starts automatically when water temperature decreases by 3°C/37°F in winter cycle or increases by 3°C/37°F in summer cycle.

In winter, if the sea water temperature drops below +10°C/50°F, the heating output of the unit is seriously affected.

Sea water circuit check and cleaning

Check the strainer located on sea water suction periodically, specially when the yacht is shored.

Never leave water in the system when the yacht is out of water.

At least once a year, it is important to have the system rinsed with fresh water for half an hour, to remove all sea water residues.

Fan-coil cleaning

At least once every six months clean the fan-coils sucking the dust trapped in the back screen. Disassemble the filter, clean it, disinfect it and reassemble it; if broken, replace it.

Winter cycle

The units can produce hot water for heating purposes, by using the heat pump, reverse cycle principle. Just set selector on "Heat" and the unit will start producing hot water at about 45°C/113°F.

The selector acts on the solenoid valves for cycle inversion. In winter, the heating capacity of the unit depends on the sea water temperature; efficiency diminishes as sea water temperature grows colder.



WARNING

Pay attention not to damage the airtight cooling circuit, because it contains a polluting and irritating gas inside.



CAUTION

The topping-up of the cooling liquid must be carried out by skilled and qualified personnel, according to the indications of the Manufacturer.



CAUTION

The air inlets of the air conditioning system must always be free; their obstruction besides involving the system performance, can also generate serious problems.

Riva

102 CORSARO *supera*

Riva

102 CORSARO *supera*

AUXILIARY EQUIPMENT ON BOARD

CHAPTER 11

11.1 PREPARATION FOR MOORING

Your yacht is equipped with deck equipment necessary for easy and safe mooring.

In addition to the anchor winch, mooring equipment is located at the bow, on the walk-around and at stern of the yacht, and consists of cleats, fairleads and anchor windlass:

- Each stern mooring furniture is arranged with two cleats and a mooring winch;
- On the starboard and port side of the stern platform there are two cleats for mooring the yacht;
- A cleat is arranged on each side of the walk-around of your yacht;
- A retractable cleat (optional) is fitted on the stern platform for each side of the yacht;
- In the anchorage area at the extreme bow, there are four cleats, four rope bridges and two anchor winches.



CAUTION

Stern cleats should never be used for tender or chase boat towing.

- 1. Mooring cleats
- 2. Warping winch
- 3. Anchor windlass
- 4. Rope bridges

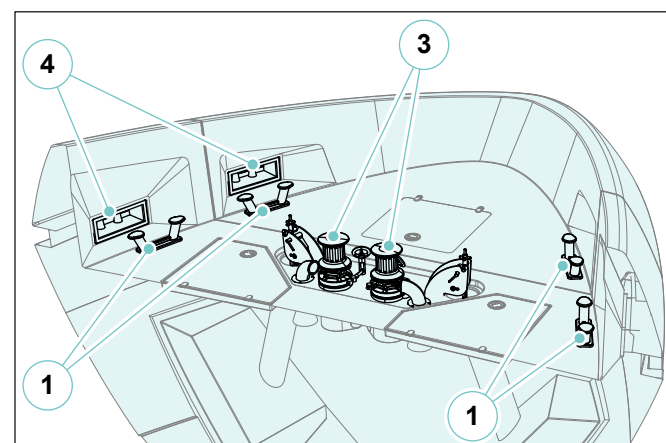
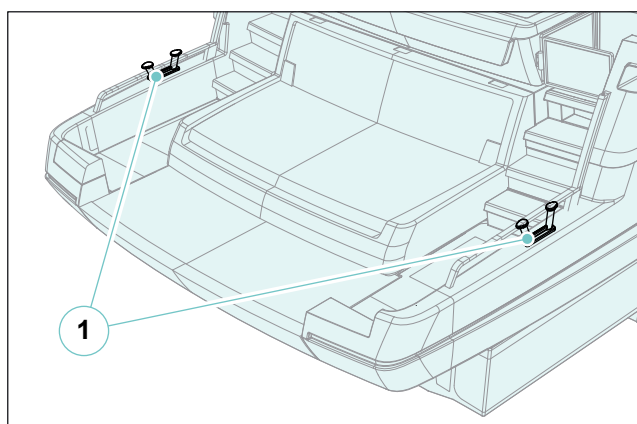
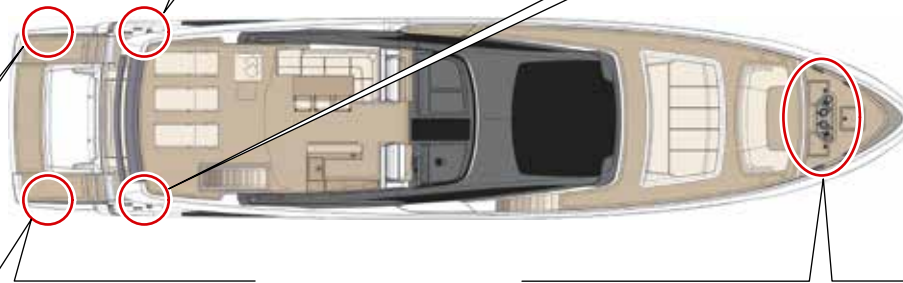
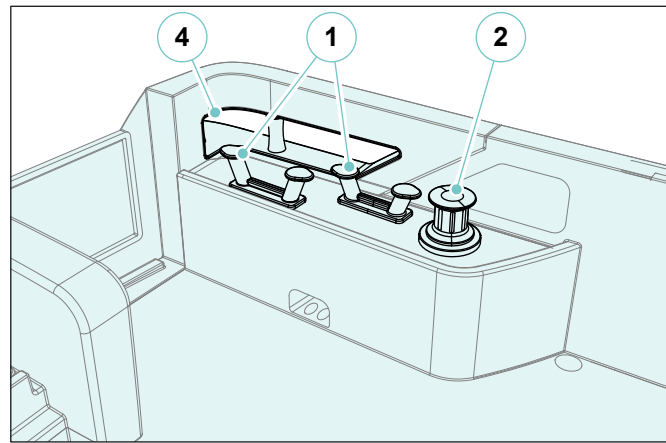

11.2 ANCHOR WINCH

The yacht is equipped with two windlasses that weigh and lower the bow anchors.

The anchors chains glides into the yacht through the chain guides and reaches the anchors winches, then winds around the wildcat and glides into the chain pit.

The anchor winches are equipped with control for chain displacement in both directions and with manual brake to lock the chain during mooring.

The anchor winches are equipped with a clutch separating the drive shaft from the wildcat; this allows using it as a warping winch for pulling a line.

1. Bushing for lever engagement

This device allows lever engagement.

2. Barrel

This device allows pulling a line.

3. Wildcat

This device allows weighing and lowering the anchor.

4. Wildcat locking wheel

This device allows locking the wildcat rotation for the chain fastening.

5. Lever

Adjusts manually the clutch opening and closing, and releases the wildcat.

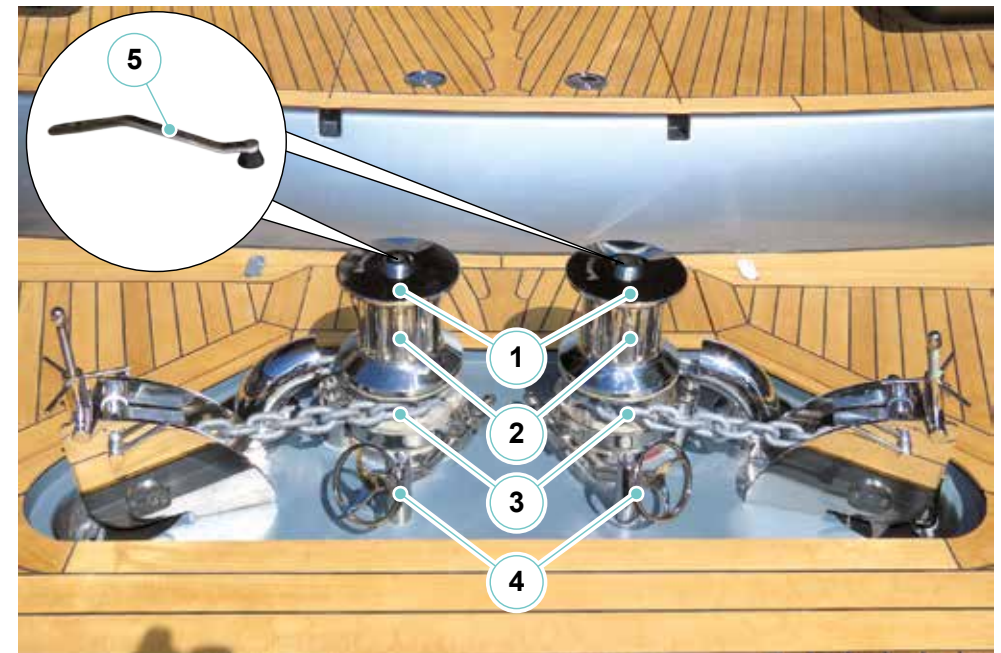

CAUTION

RIVA is exempted from any liability for any accidents or damage to persons or property caused by incorrect use of the device.

Anchor winch activation controls

The anchors winches located at bow can be activated either by means of the remote control, located in the bow peak, or by means the digital chain counters, that will measure the length of the chains installed in the main helm station.

1. **Control for anchor winch activation**
This push-button allows activating the anchor winch.
2. **“UP” button**
This button allows weighing the anchor chain.
3. **“DOWN” button**
This button allows lowering the anchor chain.

 **CAUTION**
If you intend to use the anchor, remove the slip lock and safety lock.

 **CAUTION**
Do not bring body parts or objects near the area where the chain, the line and the wildcat run. Make sure that the electric motor is not powered when acting manually on the anchor winch (also when you use the lever to loosen the clutch): people having the remote controls of the anchor winch (remote push-button panel) might accidentally activate it.

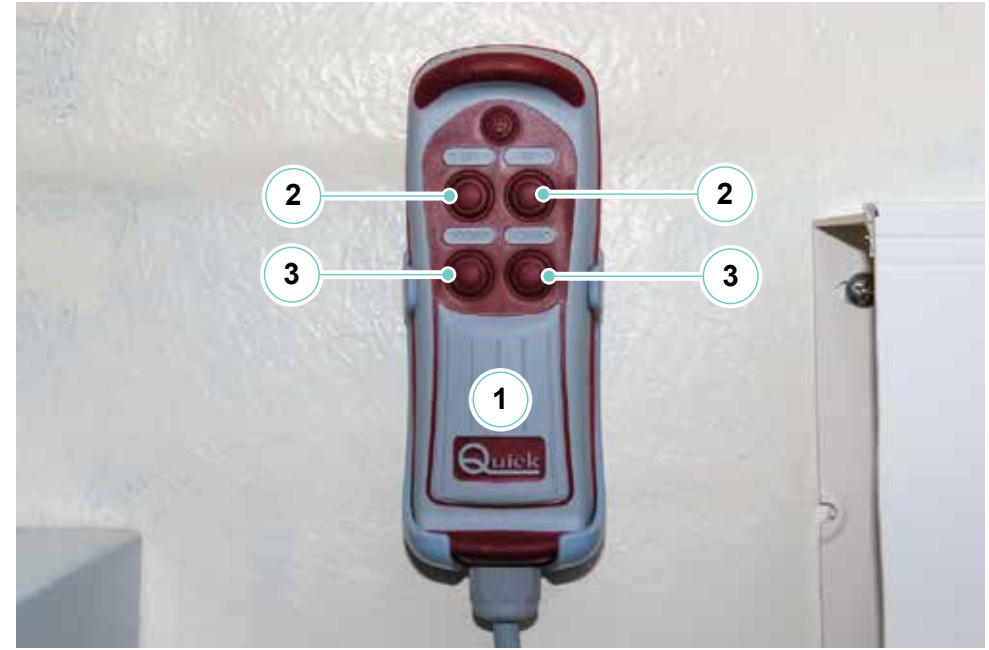

**CAUTION**

Lock the chain with its safety block before setting up for navigation.

**CAUTION**

Do not operate the anchor winch electrically with the lever in the drum housing or in the wildcat cover.

Clutch use

The wildcat is connected to the main shaft by means of the clutch. The clutch opens (disengages) when the lever inserted in the bushing is rotated counterclockwise. When rotating clockwise, the clutch will close (engage).

Anchoring

The wind and the sea conditions highly affect an anchored yacht. Make sure the anchor is set in any situation. It is necessary to understand the principles of the chain length and its effect on the anchor performance.

The radius is technically defined as the ratio between the chain length and the vertical distance from the bow to the sea bottom.

The chain length depends on the type of anchor, on the sea bottom, on the tide, on the wind and on the sea conditions.

The chain length is 5 times the depth of calm sea; it is 7:1 in normal conditions and up to 10:1 in critical conditions.

$$\text{Radius} = \frac{\text{Chain length}}{\text{Bow height} + \text{water depth}}$$

as it is necessary to know the length of the chain to be used for mooring.

$$\text{Chain length} = (\text{bow height} + \text{water depth}) \times \text{radius}$$

Anchor weighing

Start the yacht's engines. Make sure the clutch is engaged and pull out the lever. Press the control button available and start to weigh the anchor. If the anchor winch stops without any reason, the anchor might be stuck and therefore the anchor winch magneto-thermal switch trips, due to the effect of the effort. In this case, if after several attempts the anchor winch remains stuck, we suggest to manoeuvre the yacht to release the anchor.

Check the raise of the last metres/feet in order to avoid bow damage.

Anchor lowering

Lower the anchor by means of the electric controls or manually. To carry out this operation manually, open the clutch and let the wildcat rotate freely on its shaft and the chain fall into the water. To brake the anchor chain fall, turn the lever clockwise.

To lower the anchor electrically, press the control button at your disposal. In this case the anchor lowering is perfectly controllable and the unrolling of the chain or of the line is regular.

Once the yacht is anchored, lock the chain with the safety cable.

The anchor and the chain may damage the yacht bow if the anchor winch is not operated carefully.

We suggest to carry out the operation by means of the remote control located near the anchor winch; this will allow checking the lifting and lowering speed of the chain and the entry and exit of the anchor shaft into the anchor roller. Namely during those operations, an excessive gliding of the chain or a wrong entry or exit of the anchor shaft from the roller may cause damages to the yacht's bow.

Pay utmost attention: never get too close to moving parts to avoid danger and injury.



DANGER

Do not use the on board auxiliary equipment for uses or ways other than from those indicated in the manual delivered by the Manufacturer.

Always disconnect the warping winches not in use, to prevent accidental activation.



DANGER

Never get too close to moving parts to avoid danger and injury.



CAUTION

The anchoring area is a circle with the centre at the anchoring point and a radius equal to the chain length plus the yacht length.

The entire anchoring area must be free, in case of sudden variations of wind and/or current direction, especially in case of night anchoring.

At night, before dropping the anchor, check that the white anchor light works.

Before dropping the anchor, check the nautical charts: anchoring is prohibited in certain areas, in weeds covered sea bottom, anchoring is unsafe and harmful to the environment, on rocky sea bottom, the anchor may get stranded or lost.

Anchor the yacht with the engines running, both for safety reasons and to compensate the electrical consumption of the winch.

Check the anchoring point frequently.

The distance from obstacles or other yachts must be, at 360°, greater than the length of chain dropped.

During anchor riding it is advisable to leave the winch powered.

Do not reverse the winch rotation suddenly.

**CAUTION**

The anchor chain is fastened to the yacht by means of a line and an hook system. If it is impossible to remove the anchor from the sea bottom, this system will ease up to resume navigation.

**DANGER**

When the winch is operating, be extremely cautious of rotating parts; keep your feet, hands and the remote control cable at safe distance.

Anchoring operations

- Make sure that the engines battery breaker is ON;
- Turn the anchor winch switch ON, on the main electrical panel;
- When the key-pad is not used, disconnect it to prevent contact oxidation;
- Before operating the anchor winch with the electric control, check that the wildcat clutch is properly engaged and remove the wildcat stopper and the safety wire;
- Let the yacht move backward slowly; if necessary, use the engines;
- Lower the anchor until just below the waterline, and hold;
- Lower the anchor until it reaches the sea bottom;
- Once the anchor holds, leave the lock and the brake engaged.

**CAUTION**

Operate the anchor winch with the engines running, in order to provide the high current required and reduce the stress by slowly moving the yacht toward the anchor.

Lower and raise the anchor always by using the electrical control, after engaging wildcat and barrel. This latter can be disengaged both for casting off the anchor in case of need and to operate the barrel as a warping winch.

**CAUTION**

During navigation, make sure that both the chain stopper and the chain brake are securely locked.

Weighing the anchor

To weigh the anchor, perform the same operations previously described above, in reverse order.

In windy or strong current conditions, start the engines and keep the bow toward the anchor position to avoid the breakage of the chock.

Once the anchor is on board, fasten the chain stopper before resuming navigation.

**CAUTION**

Before navigation, check that the chain stopper is properly fastened.

NOTE

For further information on use and maintenance, please refer to the manufacturer's manual.

11.2.1 Anchor winch maintenance

Component	Maintenance	Notes and precautions
Reduction motor	Check and cleaning (before each navigation)	When you weigh the chain, after an anchor mooring in a muddy or weedy sea bottom, we advise you to wash the chain using the proper system. The outer part of the winch requires frequent washes with fresh water because very much exposed to sea salt during navigation specially with choppy sea.

Reduction motor:



CAUTION

Before carrying out any maintenance operation on the anchor winch cut out electric power connected with it and remove with care the chain from the wildcat.

Remove the layer of salt, which builds up on the anchor winch outer surfaces as soon as possible, to avoid dangerous corrosion, which could jeopardize its integrity. Wash with fresh water and clean the surfaces, particularly those hidden and hardly reachable and into which the salt remains trapped. At least once every two months disassemble the exposed parts, clean and check all pieces so that they do not show signs of corrosion and grease the thread of the shaft with sea grease. In case of anchor winch long inactivity, we advise you to have the motor run idle for a couple of minutes in both directions. If the electric motor turns with problems we advise you to clean or replace the brushes. We strongly recommend to separate the anchor winch from the main deck at least twice a year to remove the salt deposits building up under the base.

If oil is drawn from the body, due to deterioration of the seals, it is necessary to disassemble the gear box to replace the seals.

A complete kit of spares parts is available for this purpose.

Check and top up

Top up the gear body with oil through the level check and filling cap (1). Check periodically the condition of the electric motor terminals and of the gear motor, removing possible drifts and spreading the terminals with grease.



11.3 WARPING WINCHES

At the stern, a mooring winch is installed at the side in each mooring yacht. For their operation it is necessary to wind the line into the barrel and to operate the foot button.

The foot buttons for each winch are located at the base of the relevant mooring peak and can be activated by pressing them with one foot:

- UP: recovers the line;
- DOWN: releases the line.

Near the warping winches two mooring cleats are fitted.

For a safe anchor mooring, the lines used for warping have to be fastened to the proper cleats.

**DANGER**

Do not approach your hands to the sliding area of the mooring rope.

NOTE

For further information on use and maintenance, please refer to the manufacturer's manual.

11.3.1 Waring winches maintenance

Component	Maintenance	Notes and precautions
Reduction motor	Inspection and cleaning	For a correct maintenance and check refer to instruction manual delivered by the Manufacturer.

Reduction motor - Cleaning and checks



DANGER

Before carrying out any maintenance operation on the anchor winch cut-OFF the electric power connected with it and remove with care the chain from the wildcat.



DANGER

Do not bring body parts or objects near the area where the rope slides. Make sure that there the electric motor is not powered when manually operating the winch.

The winches are made of materials resistant to sea environment: it is necessary, in any case, to remove periodically the layer of salt which forms on the outer surfaces, to avoid dangerous corrosion, which could jeopardize its integrity. Wash accurately with fresh water and clean the surfaces, particularly those in which salt remains trapped. Disassemble the barrel according to the service intervals recommended by the Manufacturer.

MAINTENANCE

At least once a week:

- Check the operation;
- Wash with fresh water and carry out an accurate cleaning.

At least once every six months grease the terminals of the electric motor.
At least once a year disassemble and check the exposed parts.



CAUTION

Do not activate electrically the winch with lever inserted into the drum.

11.4 GANGWAY SYSTEM

The gangway is controlled by a hydraulic power unit positioned in the engine room.

NOTE

For further information on use and maintenance, please refer to the manufacturer's manual.



CAUTION

Use and suggest to passengers comfortable shoes and eventually help them with the boarding.



CAUTION

Never use slippery products for the gangway cleaning.



WARNING

Never jump on the gangway.



DANGER

Never use the gangway to lift persons, even though the same is provided and tested to lift high loads.

Always make sure that the maximum load suggested by the Manufacturer is not exceeded.



CAUTION

Always pay the utmost attention to the movements of the gangway; in case of emergency, press any button of the remote control or of the panel to stop the gangway.

1. Oleodynamic gangway unit
2. Gangway control panel

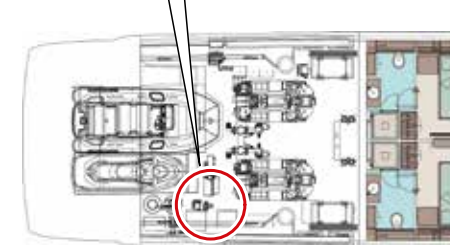
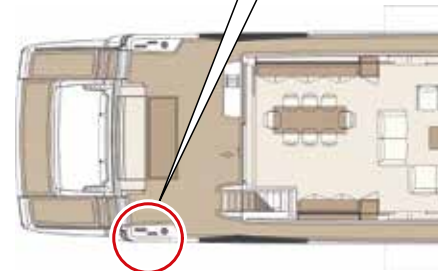
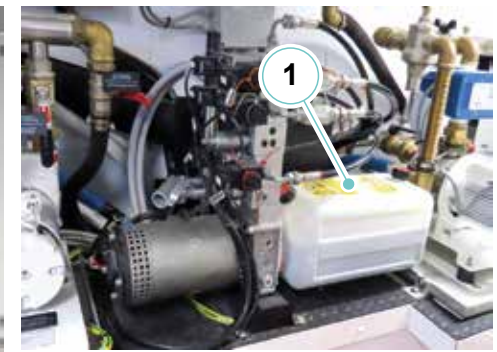

The gangway is housed in the engine room on the starboard side and exits the staircase that accesses the stern cockpit.

The movement of the gangway is assisted and allows it to be extended or retracted. Once the gangway is removed, the free end can be raised or lowered to adapt the trim to the height of the shore.

Gangway controls

The gangway movement control panel is positioned in the cockpit.

The functions are to be performed by holding down the respective panel button. The gangway can also be operated from the radio remote control.

On the aft transom there is a photocell detecting the signal sent by the radio control and transferring it to the hydraulic control unit.

The radio control must be directed towards the photocell and no obstacles must stay in their way.

1. Automatic gangway exit
2. Automatic gangway retraction
3. Switching ON gangway lighting
4. Switching OFF gangway lighting
5. Lifting the gangway
6. Lowering the gangway
7. Gangway retraction
8. Gangway exit



**DANGER**

Never operate the gangway when someone is passing nearby. When walking on the gangway, be cautious and keep hold to the handrail; as it is made of rope, it cannot be considered a rigid and safe support, but simply a help to keep balance.

**DANGER**

Do not navigate with the gangway incorrectly stowed away. Ensure that the gangway, garage hatch and stern platform are properly closed before navigation.

**CAUTION**

The hydraulic gangway, even if easy manoeuvrable, might damage people and things. Its use is recommended only to well experienced people.

**DANGER**

Be careful of moving parts and hands.

MAINTENANCE

At least once a week carry out the washing with fresh water and an accurate cleaning.

At least once a month:

- Check the oil level in the control unit, when necessary top-up;
- Check the possible presence of oil leaks and bleeding;
- Check the operation of the emergency pump;
- Check the possible presence of corrosion;
- Grease the pulley gliding races of the steel cable.

At least once every six months:

- Grease the swivel pins and the gliding sleeves;
- Tighten the locking bolts.

**CAUTION**

Always check for the correct gangway position from the shore. Never jump on the gangway.

**CAUTION**

Position the gangway in such a way that it cannot touch the shore, either because of the normal yacht swinging or of the tide change. If the gangway should strike against the shore, it could get seriously damaged.

**CAUTION**

Do not use the gangway as a springboard.



CAUTION

In order not to compromise the seals, flush the box without allowing pressurised water to enter.

Gangway system diagram:

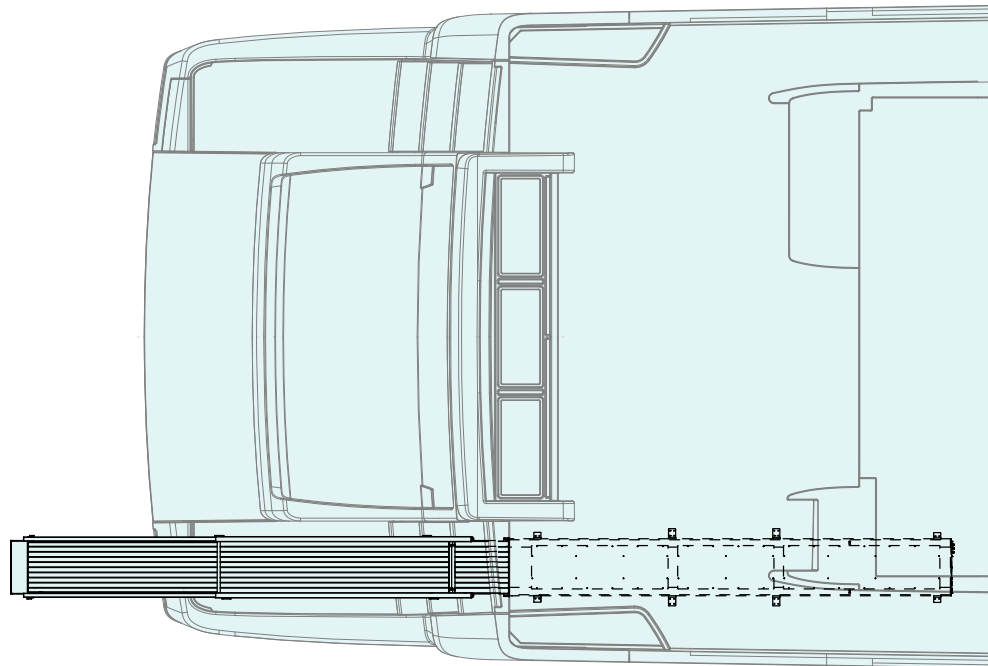
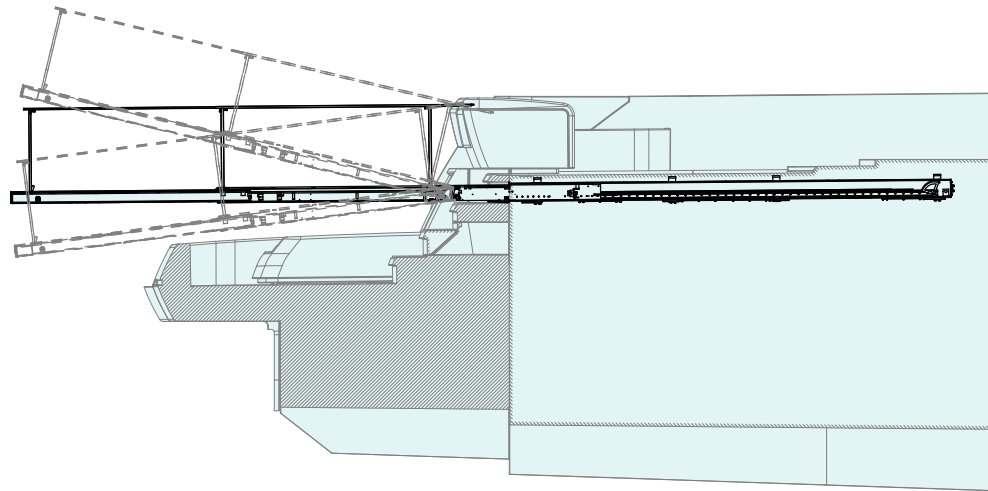

11.4.1 Gangway systems maintenance

Component	Maintenance	Notes and precautions
Gangway control unit	Oil check and top-up	Check monthly and always before each navigation the oil level inside the tank. Top up keeping the oil level at about three-quarters of the tank's capacity, and using the type of oil recommended by the Manufacturer.

11.5 GARAGE HATCH AND STERN PLATFORM

Garage hatch

The garage is located astern and can stow inside a tender and a jet ski.

The garage is closed by an electro-hydraulically controlled hatch.

The operating controls of the system are positioned near the mobile starboard mooring.

The garage hatch along with the stern platform is controlled via an electro-hydraulic control unit (24V) located in the engine room.

Stern platform system

At the stern of the yacht there is a platform that allows, once the garage hatch is opened, the launch or hauling of a tender and a jet ski.

The stern platform is moved thanks to an electro-hydraulic control unit (24V) located in the engine room.

The operating controls of the system are positioned near the mobile starboard mooring.



CAUTION

Keep the platform lowered only for the time necessary for launching or hauling the tender.



DANGER

Never navigate with the platform down.
This prohibition also applies to low-speed manoeuvres.



DANGER

It is forbidden:

- To handle objects or people with the hatch and the platform.
- To open the hatch and platform in unfavourable weather conditions.
- To leave the hatch or platform open when the yacht is unattended.



DANGER

The garage hatch and stern platform must always remain closed during navigation. Make sure that the locking devices are inserted.



DANGER

Never navigate with the garage hatch and stern platform not properly closed. This prohibition is also valid for low-speed manoeuvres with operating propellers.

**DANGER**

Loads inside the garage must be fastened with the outmost care, especially the jet ski.

**DANGER**

Fuel leaks may result in a risk of fire and explosion.

**DANGER**

Before closing the garage hatch, make sure that the jet-ski sledge has been completely closed and blocked with the relevant lock pins.

NOTE

For further information on use and maintenance, please refer to the manufacturer's manual.

Diagram of the movement of the garage hatch and stern platform:

Sezione in mezzzeria - portellone chiuso
Cross section - hatch closed

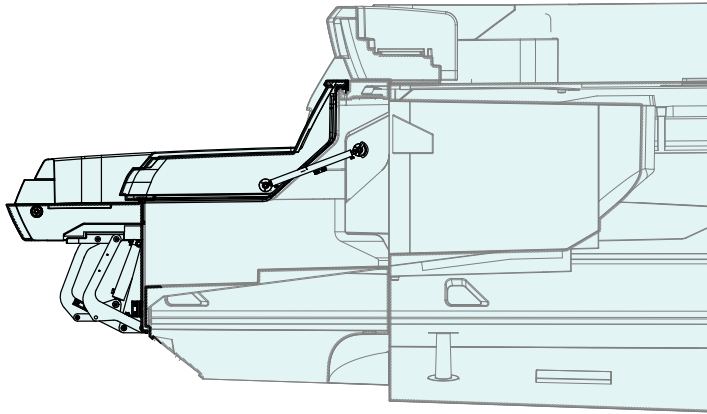

Sezione in mezzzeria - portellone aperto
Cross section - hatch open

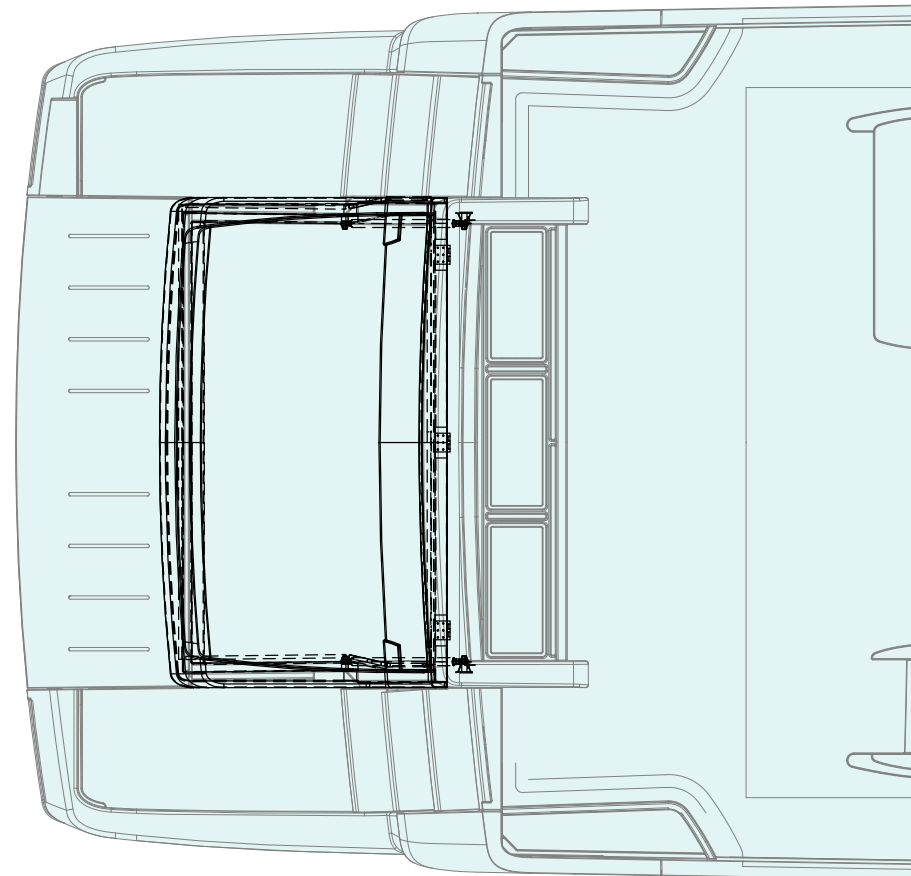
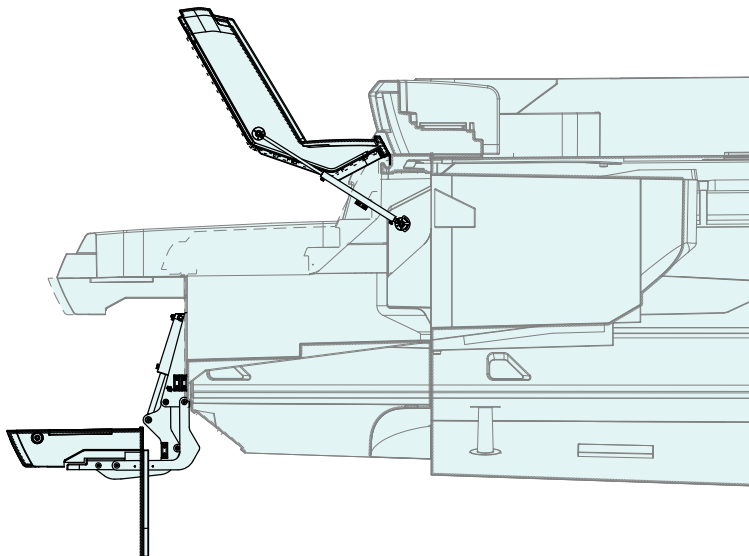

Launching and stern hauling diagram:

Tender dentro
Tender IN

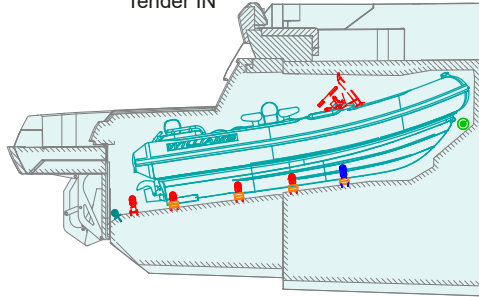

Tender estratto
Tender OUT

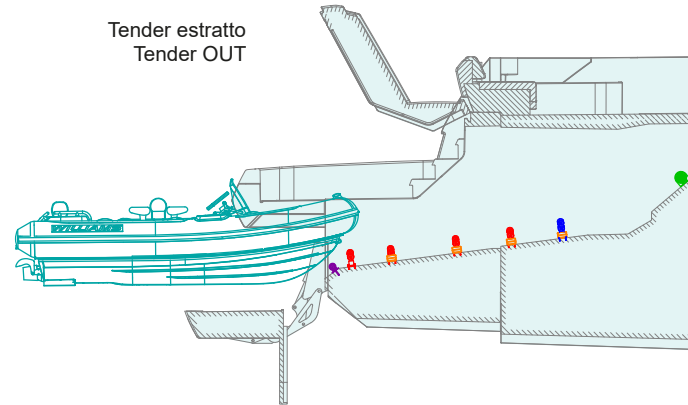

Jet-sky dentro
Jet-sky IN

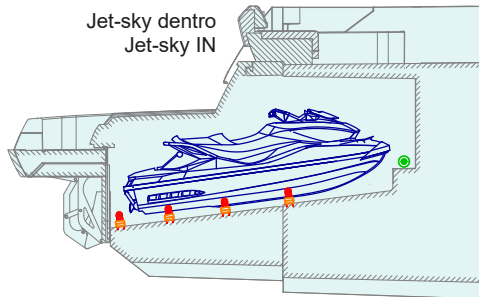

Jet-sky estratto
Jet-sky OUT

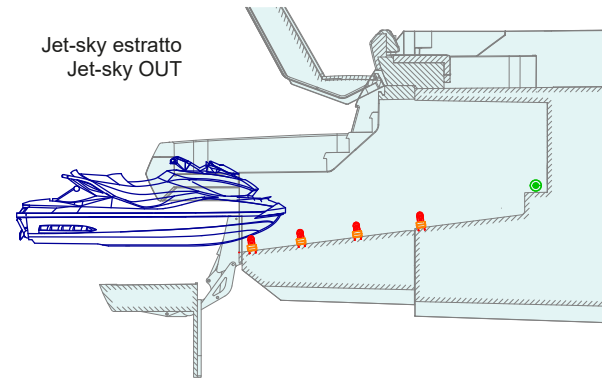

Tender e Jet-sky dentro
Tender and jet-sky IN

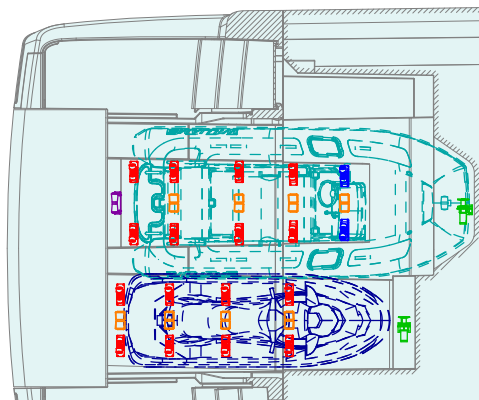

Tender e Jet-sky dentro
Tender and jet-sky IN

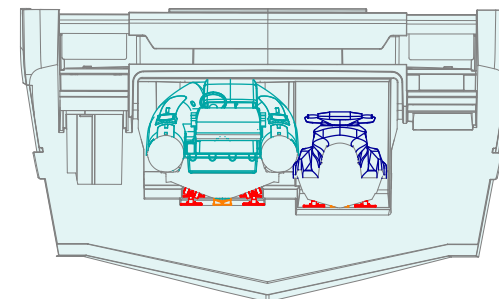

11.6 CLEANING AND MAINTENANCE OF THE GANGWAY, STERN PLATFORM AND GARAGE HATCH

Outer cleaning

To keep all our accessories and their parts in good working order, they should be cleaned carefully and thoroughly as often as possible. As the gangway and the swim ladder, are located in a very critical position compared to all the other equipment on board, being in constant contact with water and acid exhaust fumes, they require a more accurate cleaning. For a careful and thorough clearing operation, cover all the steel parts with a layer of paraffin oil. For painted parts, use a paste/cream. This will prevent the forming of rust stains.



DANGER

During cleaning or maintenance operations, make sure that no one can move the gangway, the stern platform and the garage hatch as they can cause serious damage to people; it is recommended to remove the power supply.



CAUTION

In order not to jeopardize the gangway of the seals, perform the washing in the box avoiding that water enters under pressure.



ENVIRONMENT

Do not discharge oil in the sea, but in the special areas for toxic waste disposal.



CAUTION

RIVA declines all liability for any accident to persons or damage to property caused by a wrong use of the devices.



CAUTION

After completion of some operations, check the oil level of the tank. The oil top up in the tank must be performed with the gangway completely retracted.

Ordinary Maintenance

Mechanical joints

Mechanical joints and sliding parts are greased during installation. It is advisable to verify anchorage bolts locking and a little joints greasing at each beginning and season end.

Hydraulic system

Verify oil level at each beginning and season end, if below minimum level, top up with the oil recommended by the Manufacturer. Verify the correct operation of emergency pump and hand operation of solenoid valves at each season beginning and end.



CAUTION

We recommend that you pay the utmost care during assembly and subsequent top-ups, so that there is no infiltration of possible waste, chips, dust, etc.. into the oil tank, and thus also into the hydraulic circuit.

MAINTENANCE

At least once a month grease all mechanical parts.

Electric system

Check the battery charge and the liquid level according to the procedures advised by the Manufacturer. "Daily" check the integrity of the keyboard.

The systems are controlled through logics electronic systems.

This systems have to be supplied according to specifications of enclosed technical tags.

The electronic card can't be connected directly to the battery charger. The power supply has to be stabilized by the batteries (also during recharge). Pay attention to connection and correct polarity. Pay attention to possible water intrusions which may damage the connections and the electronic cards.

Make sure that all jack plugs are well connected and well tight. In case only one of those is not properly connected, the electronic systems operation is jeopardized. Do not carry out modifications to the receiver cable (because screened). The engines and the whole systems are sized for a normal use. The continuous and uninterrupted use of the systems may cause overheating of the engines.

11.7 SWIM LADDER

The yacht is equipped with a removable swim ladder which is to be installed on the port-side of the stern platform.

The swim ladder is stowed in the garage on the left side.

In order to install the swim ladder, it is necessary to overturn the edge of the stern platform on the port-side.

NOTE

The lock latch of the flap in which the swim ladder must be installed, has a screwing closure system, which must be used correctly every time it is opened to avoid damaging the fibreglass during the movement of the flap.

**DANGER**

Before going down into the water, make sure that the ladder is properly installed.

**DANGER**

Risk of electric shock from leakage currents. Do not swim in the waters of ports or marinas.

**DANGER**

Never use the swim ladder when the engines are running. Pay utmost attention to not approach to the interceptors area, because they could be accidentally activated.

**CAUTION**

Pay attention because the ladder can be slippery. Secure the grip before starting the return on board.

**DANGER**

Never navigate with a swim ladder that is not properly stowed.

**CAUTION**

Do not use the swim ladder as a springboard.

**CAUTION**

RIVA is exempt from any liability for any accident or damage to persons or property caused by improper use of the swim ladder.

MAINTENANCE

At least once a week, wash with fresh water and clean thoroughly.

**CAUTION**

Control and maintenance operations must be carried out by specialised maintenance staff who are informed about the operating conditions of the ladder.

11.8 BALCONY HANDLING SYSTEM (OPTIONAL)

On the port side walk-around there is a balcony which, when open, allows one to look out over the profile of the yacht.

It is operated by means of the push-button panel, located near the push-button panel, which controls the dedicated electro-hydraulic control unit.

**CAUTION**

It is prohibited:

- Jump on the balcony;
- Use the balcony as a trampoline;
- Move to the balcony without having installed perimeter protections.

**DANGER**

It is forbidden to open the balcony during navigation.

NOTE

For further information on use and maintenance, please refer to the manufacturer's manual.

Balcony handling system diagram (optional):

VISTA DA SINISTRA

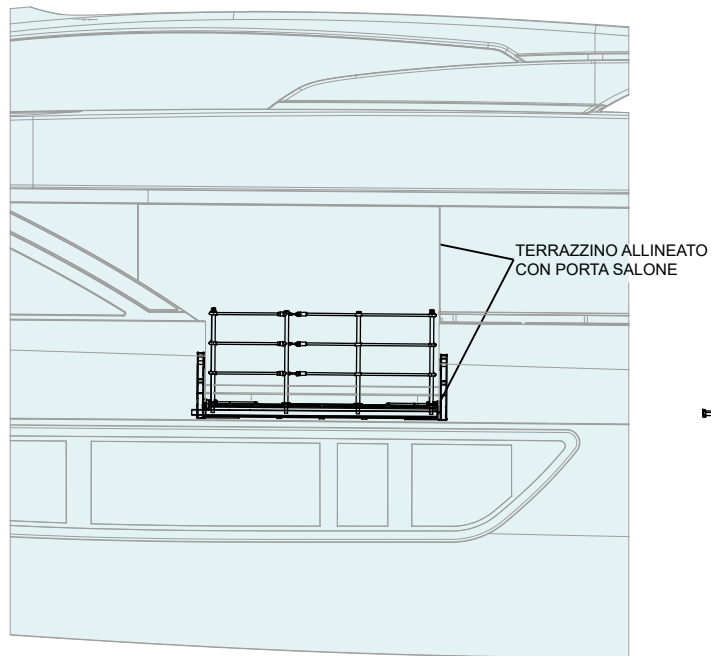

VISTA DA POPPA

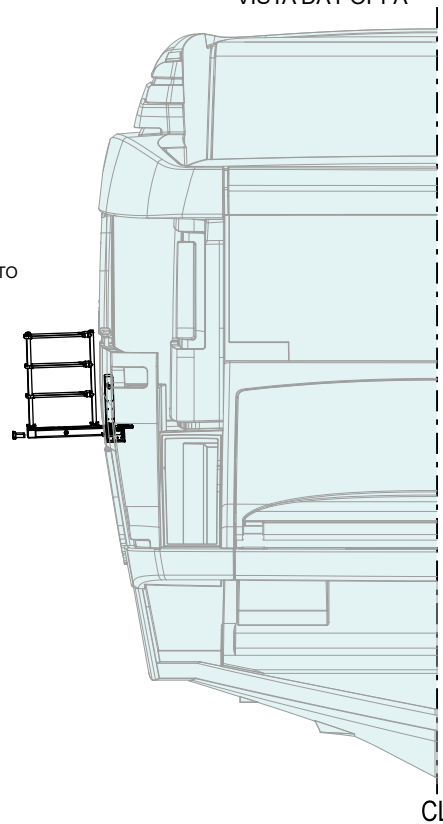

VISTA DALL'ALTO CON SOVRASTRUTTURA

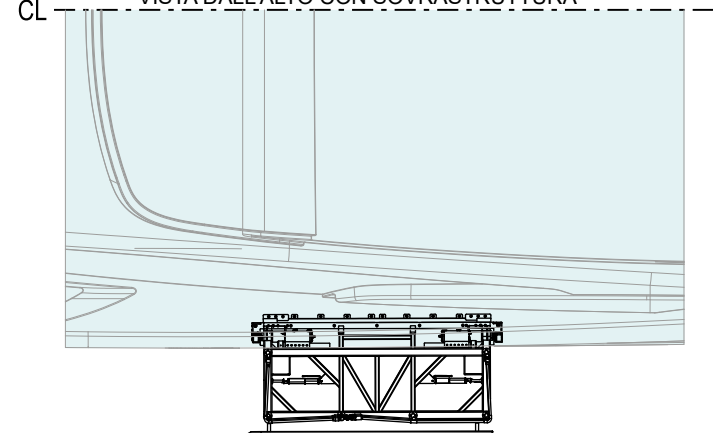

VISTA DALL'ALTO SENZA SOVRASTRUTTURA
E SENZA TIENTIBENE VERTICALE

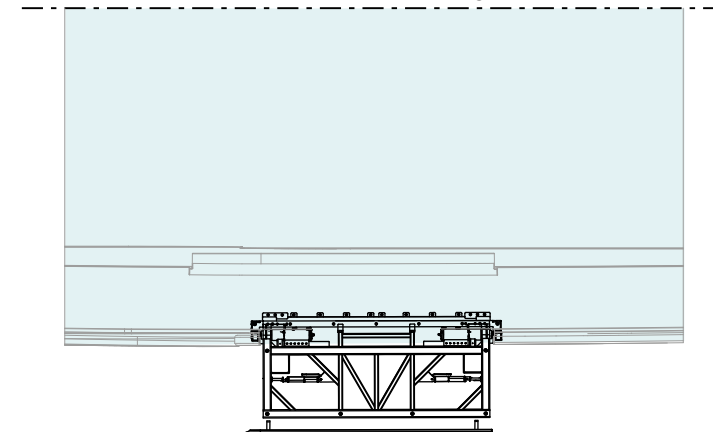

11.9 WINDSCREEN WIPER SYSTEM

In order to ensure a sufficient visibility under any weather condition, your yacht has been equipped with an efficient windscreen wiping system (4). The system is supplied at 24V and allows activating, by means of mechanical brackets and at variable speed, the windscreen wipers. The windscreen wiper system is controlled by the relevant panel located in the helm station of the main deck.

1. **ON/OFF**: wipers button activation;
2. **WASH**: washer button activation;
3. **SPEED**: wipers potentiometer speed adjustment.

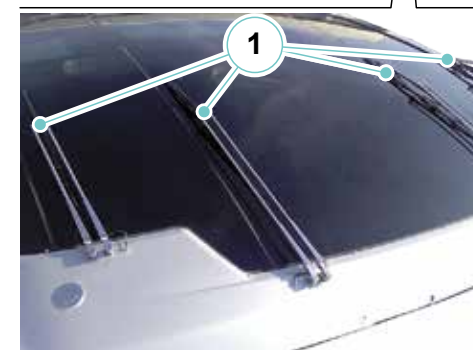
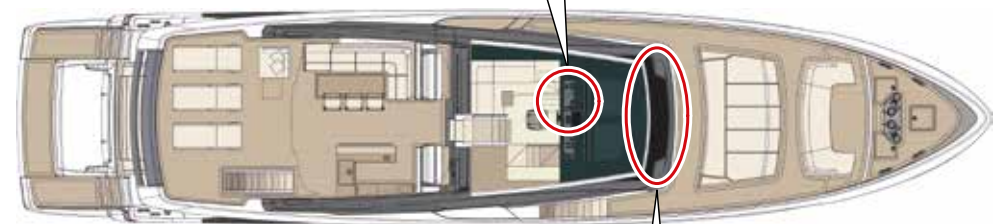

11.9.1 Maintenance of the windscreen wiper system

Component	Maintenance	Notes and precautions
Windscreen wiper blades	Cleaning	Clean accurately with fresh water after each navigation return. Clean periodically the windscreen wiping blades using specific detergent or alcohol. Apply Vaseline oil on the blades and grease the arms springs with silicone grease.
	Replacement	Replace the windscreen wiper blades at least once a year with original spares. If necessary and if the blade rubber results to be deformed or worn out, replace them more frequently.
Windscreen washer	Cleaning	If the screen washing system does not work or has a poor performance, check that the supply circuit of the nozzles is not clogged. In such a case, clean the spray holes with a needle.



WARNING

During the cleaning or maintenance operation, make sure that nobody can operate the windscreen wiping system causing damages to persons.



CAUTION

With very harsh weather, and with the freezing risk, detach in advance the wiping blades from the windscreen surface.

Before activating the windscreen wiping system make sure that ice has not stuck the blades on the windscreen surface; if necessary to spray an anti-freezing agent to detach them.



CAUTION

Do not remove foreign bodies activating the blades when the windscreen is dry.

11.10 SACRIFICIAL ANODES

The metal parts of the yacht are protected against the phenomena of electrolytic corrosion by means of anodes mounted on the stern, on the attitude correctors and on the propeller shaft nozzles. Check for their wear very frequently, as it depends also (and highly) on environmental factors like sea chains nearby, metal posts or shores, metal hulls moored nearby, electric devices, etc..

The replacement is necessary when the wear exceeds 50%.



CAUTION

Each time the yacht is lifted, check for the condition of the propeller, of the protective anodes and of the fastening system.

Replace the anode frequently.

For a spare part of the propeller shaft anode, specify the diameter of the shaft itself (105 mm).

1. Stern thruster anode
2. Stabiliser anode
3. Propeller anode
4. Propeller shaft anode
5. Prow thruster anode

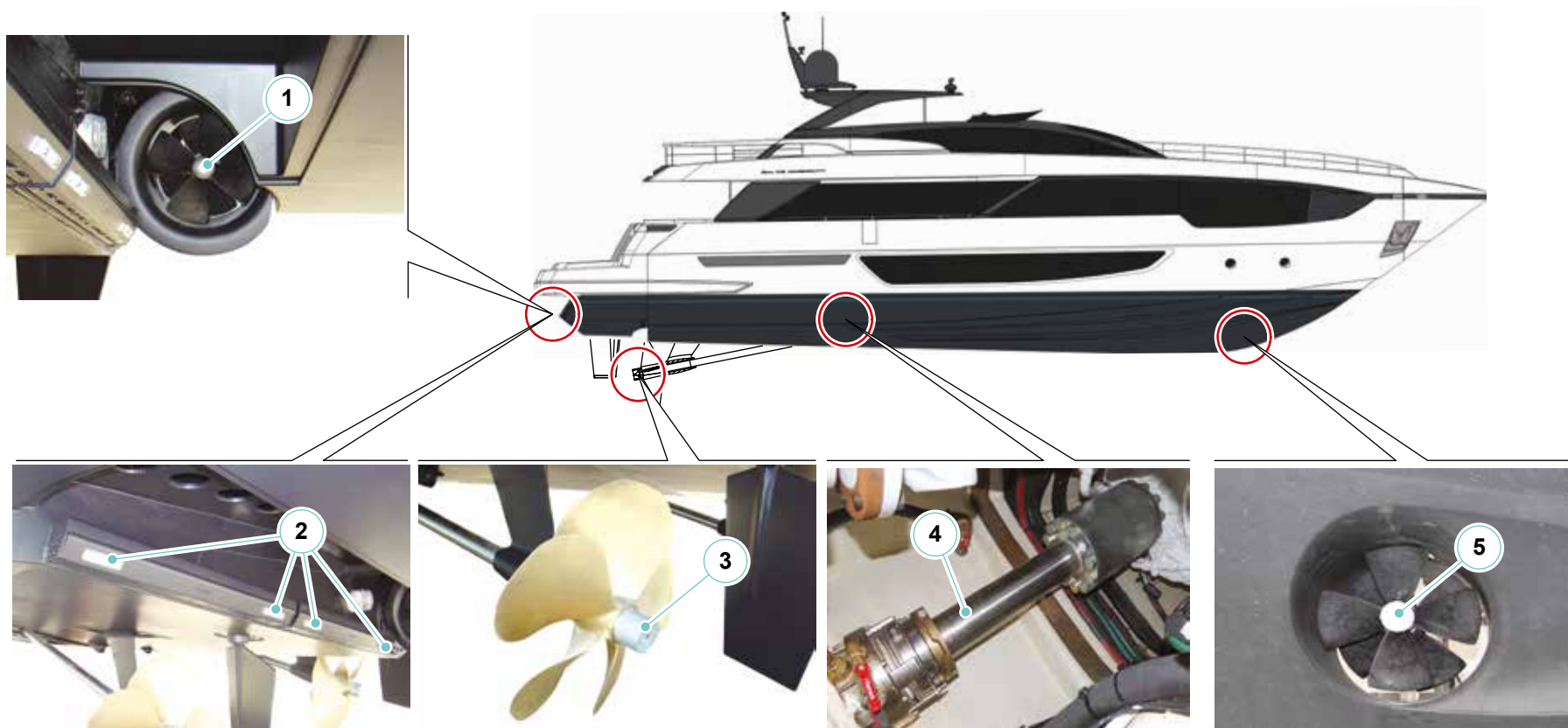

11.10.1 Maintenance of sacrificial anodes

Component	Maintenance	Notes and precautions
Sacrificial anodes	Periodical check (as necessary, according to the floating area)	Metal parts are protected against galvanic corrosion (caused by electrolytic currents due to the combination of different metal bodies such as steel and aluminium) by means of sacrificial anodes mounted on the hull, trim tabs, propeller shaft, etc.. The anodes' wear may depend on environmental factors as nearby chains, hulls or metallic shores, bad insulation of ground electric systems.

Periodical check

This operation must be carried out with yacht on dry shore or with the help of a diver.

Have the outer condition of the sacrificial anodes checked and have them replaced if they show evident signs of corrosion or if their volume is reduced to about 50%.



WARNING

To clean and check the yacht in water: disable the engines and generators start.



CAUTION

Check the anodes' wear conditions very frequently (when the yacht is on a dry shore or with the help of a diver) and replace them as soon as wear exceeds 50%.



CAUTION

Failure to replace the anodes causes corrosion on other metal parts.

Assembly/Disassembly

The sacrificial anodes are fastened to the yacht in several positions of the hull. We advise you to clean the seat of the sacrificial anode and cover with silicon the screws ends which fasten the anodes. This will ease the replacement of the anodes when worn out. We advise not to tighten the nuts fastening the anodes with glues or other materials which will hinder their removal.



CAUTION

Do not cover the contact surface between anode and hull with silicone.

Riva

102 CORSARO *supera*

Riva

102 CORSARO *supera*

INFORMATION FOR USE

CHAPTER 12

12.1 GENERAL INFORMATION

This part of the manual describes some basic rules to keep in mind at all times in order to enjoy your yacht safely.

- Periodically check the availability and efficiency of individual and collective safety equipment.
- Keep a safe distance when anchoring.
- Check that all yacht safety equipment on board are in good conditions and no maintenance activity is overdue.

NOTE

The manufacturer provides some international equipment required. The owner will have to equip the yacht of devices required by each national legislation.

- In case of use of the fixed fire protection system: do not let air into the engine room until the fire is extinguished.
- Ventilate the engine room before entering. Ventilate the lower deck compartment before entering, if portable extinguishers have been used.
- When operating the gangway, be sure that nobody is in the way.
- Oils, used filters, emulsions, coolants, electrolytes are all harmful products: avoid contacts with the skin and dispose of them carefully.
- In engine room, be cautious with hot and moving parts.
- Wear hearing protection when entering the engine room.
- Do not use open flames and do not smoke, when handling fuel or lubricants.
- Do not disperse fuel in the environment.
- Replace the fresh water stored in the tanks frequently and apply bactericides as needed.
- Do not exceed speed limits in harbour and confined waters.
- Reduce speed in proximity of other yachts or swimmers.
- Adjust speed according to sea conditions.

- Reduce speed before entering the engines room. Modify the course, if necessary.
- Before connecting the shore, make sure that the main switch on the main electrical panel is not turned ON.
- Before leaving the yacht, turn the battery breakers OFF.
- Handle hot oils carefully, in order to prevent serious burns.
- Secure engines, shafts and generator prior to performing any maintenance activity.
- Open the coolant tanks very carefully, in order to prevent serious burns.
- Do not perform any work on generator' electric board when running: serious risk of electric shock.
- Do not inhale exhaust fumes: risk of serious injuries or death.
- Before disconnecting a battery, check if the battery charger is operating. If it is, disconnect it and remove the negative wire first and then the positive one. When reconnecting the battery, proceed in the reverse sequence (the positive wire first and then the negative one).
- Replace immediately any part showing signs of corrosion.
- Never disconnect the batteries when the generators are running.
- Switch the radar OFF, prior to performing any work on the aerial.

12.2 PRECAUTIONS FOR HARSH CLIMATES

Periodically check that all equipment and machinery containing water is protected with the correct proportion of non-toxic antifreeze.

If the outside temperature is below or close to 0°C, the fresh water and sea water systems run the risk of freezing.

Piping and hoses may break from freezing and this could lead to sinking the yacht.

The systems subject to the risk of freezing include, but are not limited to, the engine and generator sea water and fresh water cooling systems, the water maker system, the fresh water system (cold and hot water piping, pumps and tanks), the windscreen washing system, the toilet and waste systems (piping, pumps and black water tanks), the air-conditioning system pumps and piping, all sea water pumps and piping, the icemakers and refrigerators, etc..

For more information on the maintenance and service requirements of your yacht and its equipment, and for special information about maintenance with cold weather, see the sections in this manual that make reference to the single components, devices and equipment, but especially consult the User Manuals provided by the Manufacturers for specific information.

12.2.1 Cooling system

The antifreeze liquid is advised for all kinds of climates: it enlarges the working temperature range, lowering the freezing point and increasing the boiling point.

When the temperature comes close to 0°C it is necessary, in order to avoid the risk of freezing, to make sure that the cooling lines are filled with anti-freeze mixture. Otherwise, replace the cooling liquid with such a mixture.

Before carrying out the system filling with antifreeze mix, it is necessary to wash the cooling circuit.

The use of antifreeze liquid is recommended for which reference is made to the specific manuals for the mixing percentages in relation to the external temperature.



ENVIRONMENT

Concentrated coolant must be treated as special waste.

When disposing of used cooling liquid, keep to prescription of Authority locally in charge.



CAUTION

Check periodically that all devices containing water are filled with the correct quantity of anti-freeze if necessary.

Each time that the outer temperature drops below 0°C the water (fresh or sea) inside the ducts may freeze and consequently break.

All systems and equipment containing water, both sea water systems (engine cooling system, generators cooling system, etc..) and fresh water systems (windscreen wipers, fresh water pump, etc..) may run this risk.

12.2.2 Fuel system

With low temperatures, Diesel fuel forms some solidified paraffin suspensions obstructing the fuel filters; in this way the normal engine supply is impossible.

The fuel as per European standard EN590 guarantees fluidity up to 0°C during the summer period, and up to -20°C during the winter period.



WARNING

There is a special type of fuel for the countries subject to very low temperatures.



CAUTION

Do not add petrol to fuel, in order to avoid serious engine damage.

NOTE

For further information on use and maintenance, please refer to the manufacturer's manual.

12.3 PREPARING FOR NAVIGATION

- Check the operation of the rudders (move them from end to end, check their correct operation, then return them to central position);
- Check interceptors operation
Operate both interceptors. If not employed during navigation, interceptors must be kept in neutral position;
- If not employed with yacht stationed, interceptors have to be kept completely "lifted";
- Check navigation lights and horn operation;
- Check the efficiency of the anchor winch and chain stopper;
- Check radiotelephone operation;
- Check documents and nautical charts;
- Check proper closing of portholes, hatches and materials proper arrangement;
- Check operation of bilge pumps and relevant indication lights;
- Cast off moorings, ensuring no obstacle can hinder unmooring operations (not aligned cables, chains, anchor log engaged in other yachts moorings, etc.);
- Check that the engine room extractors are operating;
- Ensure no flammable or other improper materials have been stowed in engine room;
- Ensure that the hull valves for the cooling of engines, generators and air conditioning system are open;
- Check that the cooling systems of engines and generators can be operated (valves open);
- Ensure engines and generators fuel circuits are operational (open valves);
- Start the generators and, after a few minutes of pre-heating, load electric power by means of the main helm station panel;
- Disconnect shore inlets/sockets (electric power, water supply);
- Connect engines and uses battery breakers;
- On the main electrical panel, check the battery charge status. If necessary, recharge them.

- Connect the 24V uses on the main electrical panel.
- Disconnect non-employed uses, after having checked their proper operation.
- Verify that all on board fire extinguishers (portable and fixed ones) are charged and perfectly operating.
- Start the engines.

**CAUTION**

The removable curtains and the relative support poles must always be dismantled and stored in the appropriate seats before starting navigation. When not in use, the poles must be stored in special places. Curtains should only be set up when the yacht is stationary and weather conditions are favourable. Do not leave curtains open in case of heavy rain. Do not leave the curtains installed in an unattended yacht. Do not let water pool on the fabric of the curtains. When not using the curtains, keep the pole engagement holes closed with the appropriate covers.

12.3.1 Weather

Learn to understand weather patterns and signs of change.

Bad weather and sea conditions can cause an uncomfortable and unsafe situation.

Here are a few basic weather-related rules:

- Check the forecast and sea conditions before leaving and while navigation;
- A sudden change in wind direction or speed, or an increase in wave height indicates deteriorating weather;
- If a storm approaches, immediately seek a safe harbour;
- If a storm hits, head the bow of your yacht into the wind;
- If you encounter fog, determine your position, set a safe course, slow down and alert other yachts of your presence with a sound signal.

12.4 NAVIGATION SET UP PROCEDURES

Accurate preliminary checks carried out with time, are fundamental for a safe navigation.

Here is some fundamental advice to consider when setting up for navigation:

- Gather information on weather forecast and warnings.
- Consult the pilot's book.
- Consult the navigation charts, and consider the cruise distance, courses, dangerous sea bottoms and flats.
- Consider the quantity of diesel oil necessary.
- Consider the length of navigation.
- Verify on the synoptic panel of the main helm station the possible lighting of the warning lights for the bilge pumps, indicating the presence of water in the engine room.

If the indicators are lit, turn ON bilge pump switches.

If pumps do not work, batteries may be discharged (recharge batteries).

If pumps work without interruptions and discharge water, this means that switches and floaters are jammed or damaged (have them checked).

If pumps work, but water does not come, this means that the suction are clogged (clean them).

- Check the cleanliness of the sea cock strainers for engine and generator cooling and for the supply of the air conditioning system.
- If they are dirty, check closing or close hull valves, remove and clean the baskets, then replace them and close the strainer housings; clean and open the hull valves.



WARNING

During navigation, regularly check the cleanliness of the sea water strainer baskets. If the yacht is crossing a dirty sea area, check the condition of the strainers and proceed with their cleaning. Taking suitable precautions is very important to prevent damage to mechanical parts (engines, generators, etc..), discharge systems and to not jeopardize the safety of the yacht.



WARNING

Once the hull valves have been reopened, make sure that no leaks are present.

- Make sure that engines and generator V belts are properly adjusted. If necessary restore correct tension.
- Check oil levels of engines, gear boxes and generator. If necessary, top up.
- Check engines and generator coolant level. If necessary, top up.
- Ensure fuel system separator filters are properly clean. If water is present, drain the filters by mean of tap.
- Check hydraulic oil levels of the various control units. If necessary, top up.



WARNING

To carry out the above mentioned checks and top-ups, refer to specific manuals supplied by the Manufacturer.

- Check liquid levels (fuel, fresh water) in the tanks.
- Ensure everything necessary has been loaded (supplies, nautical charts, documents, rockets, first aid kit, etc..).
- Check the proper fastening of all mobile components, on the main deck and lower deck.
- Ensure the load has been distributed evenly, so that the yacht maintains a proper trim.

**CAUTION**

Try to arrange load equally and securely, in order to avoid sudden displacements.

**WARNING**

The yacht's designated captain must ensure that all uses are shipped to the location of the current security systems (fire extinguishers, life raft, life buoys, etc..) and they are aware of how to use them.

**CAUTION**

Safety equipment should always be checked before each navigation, in order to ensure the good condition of the safety devices and to become familiar with their location and use. The little time spent may be very useful in case of need.

Carry out checks of the safety equipment, as indicated below.

- Ensure that life jackets are in good conditions, that the inflating device is in working order and that the life jackets are in the correct location and easily accessible (do not obstruct access hatches with anything).
- Ensure that the collective life rafts are easily accessible and that their mooring and anti-capsize line is in good condition (properly rolled up and not worn out).
- Ensure that the life buoy is in its correct location and fitted with relevant safety rope.
- Check extinguishers charge level.
The extinguisher is charged when the pressure gauge indicator is in the green sector.

12.5 FIRST PERIOD OF USE

During the first period of yacht operation, in addition to the normal maintenance and check operations indicated in this manual, we recommend to carry out following additional operations and more accurate checks. The duration of this period varies according to the frequency and use modes, such anyway to allow a correct run-in of all systems and components on board.



WARNING

We recommend consulting the technical documentation provided by the Manufactures of the various on-board systems and components; they can indicate operations, checks and specific times not included in this section of the Manual.

Following the first period of use, the hereunder listed additional operations and checks, should be performed at longer time intervals, playing anyway an important role for the safeguard and reliability of the yacht and navigation safety.

- It is recommended that new or overhauled engines should not be operated at higher loads than 75% of their maximum load and at variable speeds. After this initial run-in, the engine should be brought up to full output gradually.
- After starting each engine, check for the correct circulation of the cooling water inside the circuit, by verifying that it comes out of the drains. Check also for the presence of leaks from the sea cock valves and strainers of the cooling circuits.
- Before the engines start, check the correct tension of the v-belts.
- Check the possible presence of anomalous noises from the engines exhaust.

- Before and after navigation, check for possible leaks in the shaft lines.
- During navigation monitor constantly the temperatures and operation pressures of the devices on board (propulsion engines, generators, gear boxes).
- Check, by means of indicators installed on the main electrical panel, the correct charge condition of the batteries starting the engines and the uses. Moreover, the engine alternators must correctly charge the batteries.
- Check the efficiency of the rudders (checking in particular the rudder bar angle) and the trim tabs.
- Before and after navigation, check the correct oil level in the hydraulic systems such as rudders, hydraulic gangway, and operating propellers.
- After the generator start, wait several minutes before loading. Bring it slowly to maximum performance monitoring its correct operation.
- Check the correct load level of all extinguishers (fixed and portable ones) installed on board; the indicator needle on the pressure gauge should be set in the green range.
- Check on the indicator of main pressure gauge, possible pressure drops inside the system.
- Check before and after navigation the correct operation of all bilge pumps on board.
- Check tightness and closure of portholes and hatches.
- Check the correct sliding and closure of the salon door, considering that it is not a watertight door.



DANGER

Before performing the listed checks and maintenance operations, we recommend to read careful the Safety Rules relevant to maintenance, contained in this Manual.

**WARNING**

In the event of more or less serious anomalies, contact the RIVA After Sales & Service Department as soon as possible.

**CAUTION**

RIVA declines all responsibility concerning tampering carried out by third parties on equipment installed in the Shipyard. Such tampering or unauthorized installations will not only immediately void the warranty, but may cause damage to the yacht and injuries to the people on board.

RIVA declines all responsibility concerning periodical maintenance activities scheduled by the Shipyard or by Manufacturers, but not carried out, on equipment/components, for which it is necessary to refer to their own Technical Manuals.

**WARNING**

Avoid prolonged use of low speed motors to avoid overheating the exhaust pipes due to reduced cooling water circulation.

12.6 DEVICES SETTINGS CARRIED OUT BY THE OWNER

Magnetic compass:



CAUTION

The yacht is delivered with a compass not compensated. The compass compensation has to be carried out at Owner's responsibility, after the installation of any additional electronic equipment, and should be performed by an authorised and qualified technician. Any electrical or metallic items located in its proximity may influence the compass.

Compensation

The compass compensation must be carried out by the Authorized Experts of the Marine Authority. As a consequence of variable magnetic fields on board and the prolonged anchorage always in the same bow, the compass turns for the relevant correction must be carried out at least every year.



CAUTION

Never unscrew for any reason screws and filling caps (1). The only screws to be regulated are the ones of the adjusters (2) (by means of the magnetic screwdriver at disposal).

When the adjusters screw slot (2) is horizontal the setting is neutral, when it is vertical it is maximum.

Have this operation carried out only by specialized personnel.



12.7 REFUELLING

- Ensure the yacht is properly moored, stop engines and generators if running.
- The fuel filler (1) is located into the suitable peak on each lateral walk around of the yacht.
- Wash the teak with fresh water ahead of time to prevent soiling it accidentally.
- Loosen the filling nozzle, make sure that refuelling pump has suitable dimensions, then insert the pump and hold it still.
- Do not top up the tanks at highest level, so as to allow the fuel to expand into the tank, without spilling out from vents.
- Tighten filler plug firmly and remove any fuel drop from the hull and the teak.

**CAUTION**

The inlet plug carries the indication "DIESEL" to avoid accidental introduction of different liquids.

To avoid damage to the system and tanks, we recommend replenishing by gravity and not by pressure.

**CAUTION**

When refuelling open the fillers on both sides of the yacht.

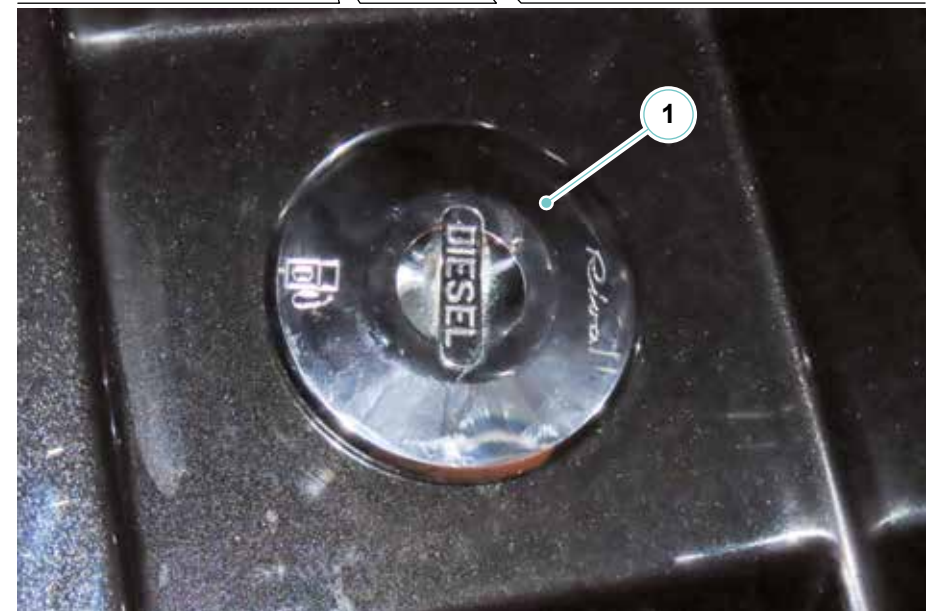

**CAUTION**

Refuelling should be performed at the end of navigation, in order to allow fuel cooling down, without condense. Drain the tanks, every 2 or 3 refuelling. Before refuelling, wash the teak with fresh water to avoid its contamination with fuel.

**DANGER**

Do not smoke during refuelling, do not leave the yacht unattended, do not leave the engines running.

**ENVIRONMENT**

Do not scatter fuel in the environment: it causes pollution.

**DANGER**

Fuel leaks create a fire and explosion hazard.
Fuel cannot be stowed inside the garage.

**CAUTION**

Stop all engines when refuelling.

**DANGER**

It is forbidden to smoke, use naked flames or keep mobile phones switched on during refuelling.

**CAUTION****Explosion/fire hazard**

- Stow flammable material in a safety-approved container. Never stow flammable material in non-vented areas.
- Check bilge and engine room for fumes.
- Keep the ventilation system free of obstructions. Never modify the ventilation system.
- Inspect the fuel system for leaks.

**CAUTION****Explosion/fire/pollution hazard**

Fuel system connections that are too loose or too tight can leak, resulting in fuel spillage, environmental pollution and explosion/fire hazard.

12.8 WATER SUPPLY

- Ensure the yacht is properly moored; we suggest to stop the engines and the generators, if running.
- The water inlet filler is located in the suitable peak along the starboard side walk-around of the yacht.
- Loosen the filling nozzle and insert the hose (it must have suitable dimensions).

At the end of filling, remove the hose and tighten the filler plug.

**CAUTION**

Often replace fresh water in the tanks and, if necessary, disinfect it with suitable products. Avoid leaving the tanks full in case of frosting risk. During the supply, do not leave the yacht unattended.

**CAUTION**

The inlet plug is marked "WATER" to avoid accidental introduction of different liquids. To avoid damage to the system and tanks, we recommend replenishing by gravity and not by pressure.

**CAUTION**

Before refilling the fresh water tank, check that the water supplied by the shore fresh water system is potable.

12.9 MOORING AND UNMOORING**CAUTION**

Before the unmooring operation, ensure that engines, gear boxes, rudders and bow/stern thrusters are in good working order. During such manoeuvres, the Captain should prevent any unpleasant noise, and/or wake that might bother other people. Before unmooring, make sure that all doors, hatches, port-holes, etc.. are closed.

**CAUTION**

The steering wheels of the helm stations are not interlocked. Before starting the manoeuvre, make sure that the unused station is free from people who may interfere with the controls.

**WARNING**

Before starting the manoeuvre, make sure that people on board, especially children, do not obstruct operations and that they stay in suitable places.

**DANGER**

Check with extreme care that no one boarded is in danger (with legs or arms outside edge, in precarious balance or moving on wet or slippery surfaces) and that the fenders are well positioned and fastened.

The yacht is equipped with very powerful engines, with very efficient rudders and with high-performing bow/stern thrusters.

The bow/stern thrusters are to be used at very low speed, or without fresh way; at higher speed, it is possible to obtain a more correct reaction, by using the engines throttles in an off-set way.

The ability to exploit these excellent qualities depends mainly on the “familiarity” the Captain has with his yacht. Practice is the only way to acquire confidence, and finally you will be able to safely perform mooring and un-mooring manoeuvres even in very difficult or crowded areas.

A basic rule, that should always be applied, is to manoeuvre at low speed, so as to have enough time to react and to better evaluate the situation; because, in case of accidental contact with other yachts, you will not cause any serious damage.

Before unmooring check following:

- That there are no other yachts manoeuvring nearby;
- That the mooring ropes are not damaged;
- That the fenders are positioned and well fastened (in case of wind or surf prepare a passenger with fender to avoid damages);
- That there are no floating objects or loose ropes which can damage the propeller.

If the yacht is moored with the stern to the shore:

- Undo the stern lines, haul in the chain, until distant from the shore, and head to the exit.

If the mooring is on the side:

- Ease away the mooring rope from stern, warp on bow rope to move away the stern from the shore, manoeuvre for way out.

12.9.1 Leaving the mooring

The yacht is steered by means of the steering wheel that moves the rudders (rudder operation is independent from the engine operation).

In case of need and/or when in confined waters, manoeuvre the yacht by using the engines (changing the rpm and reversing the engine direction of rotation).

It is a good rule not to leave the steering wheel, particularly when cruising at high speed or in confined waters.

Do not exceed the speed limits when operating in confined waters, harbours and wherever required.

Keep in mind that the rudders effect is proportional to the propellers rpm and to the yacht fresh way, especially with headway; as a result of an high rpm and an high speed, the rudder efficiency is high, while when the engines are idling, with low fresh way, the reaction of the tiller angle is almost negligible.



WARNING

Before unmooring disconnect the electric cables for shore electric power supply.

12.9.2 Strength points

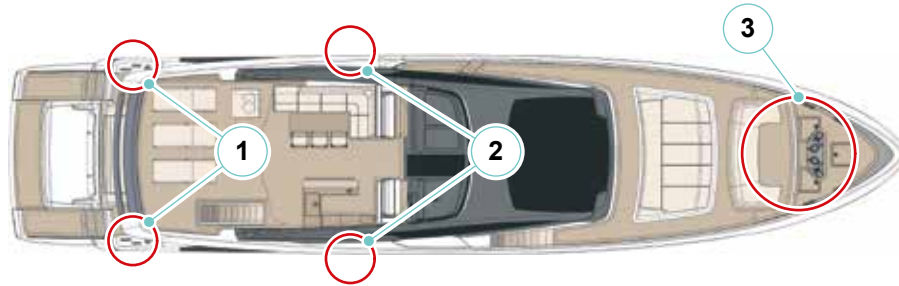

1. Stern tonnage
2. Side cleats
3. Stern mooring



CAUTION

It is the Owner's/operators' responsibility to make sure that the mooring ropes, the towing ropes, the anchor chain(s), the anchor lines and the anchor(s) are suitable for the intended use of the yacht, i.e. the resistance of the ropes or chains must not exceed 80% of the resistance to breaking of the relevant strength point.

12.9.3 Mooring manoeuvre

Before setting back for the harbour, stop in free waters and test the gear boxes and the bow/stern thrusters. Besides check:

- That mooring lines are ready for use;
- That the mooring point and the berthing course are free from incoming, leaving or moored boats or boats with the signal of unsteered craft at shore;
- Check that on the main electrical panel, all necessary uses are supplied (anchor winch, bow/stern thrusters, etc..). Disconnect unnecessary uses;
- That the wheel trim tabs are in a raised position;
- That the yacht hook is easily accessible and does not hinder any passage;
- The operation of the audible warning devices and the adjustable headlamp;
- In the case of a night approach, a hand-held (working) torch is at hand;
- That the passengers will not interfere with operations and, if participating, they know whom to listen to and what to do;
- That bilge, grey water tanks and holding tanks are empty;
- That mooring ropes and fenders are correctly arranged.

Lift the trim tabs, if necessary, and reduce the speed.

If the yacht is moored with the stern to the shore:

- Warp on stern ropes and on an anchor log, so as to haul the shore.

If the mooring is on the side:

- Warp on bow and stern ropes, so as to haul parallel to the shore.

Once moored:

- Stop the engines;
- Ensure that indication lights on the dashboard are OFF and remove start keys;
- Cut out not in use electrical equipment and check the general condition of the main electrical panel and the indication of voltmeters and ammeters;
- Check bilge pump switches and their regular operation;
- Check bilge and dry it;
- Ensure there are no leakages from shaft stuffing boxes;
- Rinse the yacht with fresh water;
- Connect shore electric power supply;
- Stop the generator, once cooled down.

Before leaving the yacht, check following:

- Lower deck lights are not powered;
- Ensure that navigation lights and external lights are not powered;
- Ensure that unnecessary devices (plotter, radiotelephone, anchor winch, etc..) are not supplied;
- Ensure that devices in use are powered (automatic bilge pumps);
- Ensure that the shore socket is properly connected and the cable cannot be damaged;
- Disconnect battery breakers;
- Make sure that the devices (life jackets, yacht hook, torches, etc..) are in their correct positions;
- Ensure that all bottles and containers with flammable liquids are properly sealed;
- Make sure that no food residues are left around (they could rot or clog scuppers etc..);
- Ensure that the gangway is in the right position and properly fastened;
- Ensure that mooring is correct (in case of bad weather conditions, tighten the mooring lines as much as possible and check the distance from other boats is appropriate; ensure fenders are properly fastened, etc..);
- Ensure that sea water intakes are closed;
- That lower deck compartments are properly closed;
- That all portholes and the garage hatch are well closed.

12.9.4 Unattended mooring

If the yacht is moored and left unguarded, operate as follows:

- Close sea cocks and overboard drain valves of sea water circuits.
- Check the condition of the main electrical panels and disconnect all unnecessary uses.
- Check all on board compartments, portholes, skylights and bilge.
- Ensure the yacht is safely moored.
- Disconnect all unnecessary uses.



CAUTION

The electric power supply from shore must be disconnected, especially if the yacht is left unattended for a long time.

It is necessary to recharge the batteries periodically.

Overboard outlets and drain pipes should be regularly checked, in order to ensure good buoyancy.

The electric system should be regularly checked, in order to prevent fires on board.



CAUTION

Inform the Harbour Authority about the location of the on-board fire-fighting system and hand them the keys for cockpit opening and fire-fighting control access.



CAUTION

Disconnect all pumps of the yacht.

12.10 YACHT OPERATION DURING NAVIGATION



WARNING

Personnel must not be under the influence of alcohol or narcotics. The yacht's skipper must be experienced in the use of tools and controls and know how to manoeuvre the yacht at any speed and in any sea condition. You should be certain that persons intending to operate your yacht are completely knowledgeable about its proper operation. If you are not certain about an individual's qualifications or competence, the person must be supervised by a qualified operator.

The yacht is very efficient and is equipped with very responsive rudders; nevertheless, because of its size and performance capability, only persons experienced, competent, responsible, cautious and with necessary qualifications should operate the yacht.

The yacht is steered by turning the helm wheel on the dashboard. Do not leave the helm wheel unattended while navigating.

Keep in mind that the rudder effect is proportional to the propeller rpm and the yacht's speed, especially when moving forward.

As a consequence, the rudder efficiency is high at high rpm and speed.

On the contrary, when the engines are idling and the yacht's speed is low, the yacht's reaction to the tiller angle is almost negligible.

If necessary, or when in restricted waters, you can steer the yacht with the engines by varying and/or reversing the engine speeds and alternating power from port and starboard engines.

At low rpm, operating on a single engine, alternating port and starboard engines and using the "back and fill" method for turning the yacht is the recommended practice. Learn and practice the skills for handling the yacht at low speed and engine rpm.

When the yacht's speed increases, the transition of the hull from displacement mode to planing mode is a critical phase.

The transition to the planing mode should be done as quickly as practical to achieve fuel efficiency and provide a comfortable motion.

The minimum glide speed depends on the displacement of the yacht, the distribution of loads, the position of the interceptor and the sea conditions.

Adjust the speed and position of the interceptor according to the sea conditions and the load of the yacht to ensure easy movement of the yacht and avoid stress on the structure due to the effects of sea conditions.



WARNING

At high speed, the use of the autopilot is dangerous and not recommended. Anyway, always be very careful during navigation also when the autopilot is in use.

The high quality engines allow running the yacht safely at cruising speed for extended periods of time.

12.10.1 Operating in shallow water**CAUTION**

COLLISION HAZARD - Use extra caution in shallow water or where underwater/floating objects may be present. Hitting an object at high speed or at an acute angle can seriously injure people and damage the yacht.

12.11 PRECAUTIONS DURING NAVIGATION

- During navigation, do not loosen the anchor chain safety lock because it can seriously damage the bow of the yacht.
- Maintain a safe speed for the sea conditions, visibility, and when near other yachts.
- Do not exceed speed limits in harbour and confined waters.
- Follow all navigation rules applicable to the waters in which you are operating.
- Provide laminated plastic reference cards for the Rules of Navigation and have them available for quick reference at each helm station.
- Consult charts for information on locations of reefs, rocks, shoals, or other hazards to make sure that the yacht is not at risk of grounding or collision with fixed or floating structures.
- Frequently check that your route ahead and around the yacht is unobstructed (no yachts or objects in the expected route or approaching your yacht).
- Frequently confirm the yacht's position as you cruise, using all available aids, such as charts, visual observations and bearings, depth soundings, GPS, radar, etc..
- If the yacht is controlled by the autopilot, keep a good visual guard. The autopilot cannot see.
- Before night navigation, make sure that navigation lights and search lights are operational. Ensure that the correct navigation lights are turned ON for operation at night. Do not keep the anchor riding light ON while the yacht is navigating.
- Use navigation lights in all conditions of reduced visibility, such as fog and rain and at all times between sunset and sunrise.



WARNING

When navigating at night, visual sharpness is crucial for a safe passage. To avoid collisions, reduce speed at night to compensate for limitations of visibility. Avoid switching on inner lights that may affect the pilot's night vision.

- Know the characteristics of the sea bottom before to anchoring. Keep away of other anchored yachts.
- During anchoring, pay special attention to avoid rotating parts of the winch and take precautions when handling the anchor chain as it comes off the winch. Caution is needed to avoid injury to hands and fingers. Also, take care to avoid entangling feet and legs in the anchor rode.
- When the yacht is navigating, all persons on board must be seated in designated areas to avoid injury from falls caused by the movement of the yacht in rough seas and active lapping areas, in the event of sudden changes in speed or during manoeuvres. No one should be seated on the stern platform when the yacht is navigating.



WARNING

For comfort and safety, reduce the speed in the presence of waves.

**WARNING**

Persons entering the engine room during navigation must be aware of the hazards due to the movement of the yacht and exposure to high temperatures, hot components and machinery operating in such an environment. Prior to entering the engine room, set the yacht on the most comfortable heading for sea and wind conditions. People in the engine room should maintain communication with the pilot.

**CAUTION**

To avoid heavy injuries or even death caused by hazards in the engine room, avoid the contact with hot and/or moving parts, while you are working in this area, wear proper safety clothing, safety goggles and safety gloves. Be extremely cautious in proximity of hot and moving parts. Wear hearing protection if the engine is running.

**DANGER**

It is forbidden to carry out sudden manoeuvres at high speed. This can result in accidents to people on board.

**DANGER**

It is forbidden to stand or sit on the bow cockpit while navigation at high speed.

**DANGER**

It is absolutely forbidden to perform reverse run with one of the two engines stopped. This operation is allowed only in case of life danger for the people on board and for the safety of the yacht itself, however when the engine is running it should not run higher than 1000 rpm.

**WARNING**

In order to obtain the best compromise between comfort and speed whilst minimising consumption, keeping the motor running speed in the range between 1500 and 2000 rpm below the maximum permitted revolutions is recommended.

**WARNING**

During navigation, keep the stern door closed to prevent engine exhaust fumes and water splashes from entering the interior. Since the closure is not waterproof, do not direct water directly onto the door when washing the yacht.

Observing the following guidelines will improve comfort, minimize noise inside the yacht, avoid damage and assist in the proper operation of the yacht.

- Do not run the engines at idle longer than necessary.
- Avoid sudden accelerations and decelerations, which create stress on engine turbochargers.
- Run at idle for a few minutes before shutting down the engines, to allow a gradual cool-down.

- Once the yacht is at cruising speed, the engine instrumentation readings should remain steady. However, if, during normal operating conditions, the engine gauges show abnormal or contradicting values, investigate for possible systems and/or equipment problems or failures (stop the engines).
- Monitor the control panel gauges and system condition alerts frequently.
- Once in the open sea and away from other boats, gradually increase the engine revolutions until you reach the desired speed. Adjust the position of the interceptor to achieve the best performance. For information regarding the adjustment of the wheel alignment correctors, refer to the system-specific manual.
- Adjust the speed to accommodate sea conditions.
- Check the engine exhausts. Black smoke means in particular dirty filters or unburned fuel, due to improper calibration of injection pumps or injectors. White smoke may mean presence of water in the fuel. Bluish smoke may mean abnormal oil combustion.
- In case of abnormal vibration, reduce speed and run at slow rpm until the cause of the vibration is determined. If the vibration is strong, take the engines out of gear. It may be necessary to check the propeller condition. It may also be necessary to have a specialist check the propeller shaft alignment.
- Perform a visual inspection of the bilges periodically.

For the supply of fuel to consider the distance that we intend to cover.



WARNING

When the yacht is navigating, all persons on board must be seated in designated areas to avoid injury from falls caused by the sudden movement of the yacht in active lapping areas, in the event of sudden changes in speed or during manoeuvres. No one should be seated on the stern platform when the yacht is navigating.

12.12 PREPARATION FOR ANCHORING



CAUTION

If the anchor has to be used, unlock it, check the wildcats clutch engagement and test the operation of the anchor winch from the helm station in use.

Please note that the anchor windlass system does not have any safety limit switches, so it is recommended to manoeuvre the last few metres of chain “manually” via the remote control when it is close to the cube or when it is calculated that almost the entire chain is being spun.

To avoid overheating of the anchor winch, it is advisable to help recovering it, by moving slowly the yacht toward the chain, without approaching it too closely, so as not to damage the hull.

If you weigh the chain after an anchoring on a muddy or weedy sea bottom, we suggest washing it during the weighing, using the button on the helm stations.

12.13 SUGGESTIONS FOR NAVIGATION UNDER SPECIAL CONDITIONS

12.13.1 Navigation with bad weather conditions

Your yacht has been designed for a safe and comfortable use, under all weather and sea conditions, bad or favourable; in any case, the navigation safety (especially with bad weather) depends mainly on the Captain's behaviour, who should either not set off or reduce the yacht's speed, sometimes considerably, and steer the yacht with the proper attitude.

It is very important during navigation with harsh weather, to make sure that all pieces of furniture, hatches, and mobile parts, are duly fastened or stowed, to avoid damages and especially to avoid hurting persons on board.

The reliability of the machinery, also due to a perfect maintenance, the scrupulous check during the pre-navigation phase and a Captain of proven experience assume, under adverse sea and weather conditions, an even greater importance.

The following table shows the maximum speed allowed in function of the wave height, in order to safeguard the yacht structural integrity.

Speed (knots)	Significant wave height (metres)
10	2,98
11	2,63
12	2,34
13	2,10
14	1,90
15	1,74
16	1,59
17	1,47
18	1,36
19	1,27
20	1,18
21	1,11
22	1,04
23	0,98
24	0,93
25	0,88
26	0,84
27	0,79

Beaufort Scale	Descriptive Term	Wind speed		Probable wave Height (metres)	
		m/sec	knots	average	max
0	Calm	0 - 0,2	until 1	-	-
1	Light air	0,3 - 1,5	1 - 3	0,1	0,1
2	Light breeze	1,6 - 3,3	4 - 6	0,2	0,3
3	Gentle breeze	3,4 - 5,4	7 - 10	0,6	1,0
4	Moderate wind	5,5 - 7,9	11 - 16	1,0	1,5
5	Gentle wind	8,0 - 10,7	17 - 21	2,0	2,5
6	Fresh wind	10,8 - 13,8	22 - 27	3,0	4,0
7	Strong wind	13,9 - 17,1	28 - 33	4,0	5,5
8	Gale	17,2 - 20,7	34 - 40	5,5	7,5
9	Strong gale	20,8 - 24,4	41 - 47	7,0	10,0
10	Storm	24,5 - 28,4	48 - 55	9,0	12,5
11	Violent storm	28,5 - 32,6	56 - 63	11,5	16,0
12	Hurricane	over 32,7	over 64	14,0	



WARNING

RIVA declines all responsibility for the improper use of the yacht, in relation to the wave height conditions.



WARNING

Before undertaking navigation, it is necessary to be aware of the sea and weather conditions you will find along the transfer route and in the area you want to reach.

12.13.2 Navigation with one only engine

The yacht is driven by two powerful propulsion systems designed to operate together and at the same time.

In case of failure of one of the propulsion systems, you may navigate with only one engine.

Therefore we suggest You to:

- Shut OFF the failed propulsion engine;
- Adjust the position of the rudders in the opposite direction to that of the faulty propulsion system; if the rudders are unable to counteract the asymmetrical thrust of the system in motion, also help by lowering the trim tab on the side of the faulty system, or reduce the speed again;
- Head to the nearest landing at a reduced speed;
- Keep the yacht at speed that allows you the best manoeuvrability.

In case one engine stops due to a failure and the gear box is in idle position, during navigation keep constantly an eye on the oil temperature of the gear box connected with the failed system.

The propeller shaft is kept rotating thanks to the water flow through the propeller, under these conditions also some parts of the gear box are kept rotating. If the temperature increase excessively over 80°C, lock the propeller shaft by engaging the gear box: in this way the resistance will be higher, because the gear box is jammed, but oil will not overheat.



WARNING

The yacht has been designed to navigate driven by two engines; please remember that it is possible to navigate with one engine only in case of emergency and for a very short time.



DANGER

It is absolutely forbidden to perform reverse run with one of the two engines stopped. This operation is allowed only in case of life danger for the persons on board and for the safety of the yacht itself, however when the engine is running it should not run higher than 1000 rpm.

This yacht is equipped with a Trailing Pump on the gearbox module; this system allows navigation with a single engine while safeguarding the mechanical components of the engine switched off.

For long distances a “sea water” cooling circuit has been provided with the following modes of use:

For prolonged navigation with one of the two engines switched off, operate as follows:

- With both motors working, the 3-way valves, positioned between the engine and the inverter, must be kept in configuration “A” (no partialization of the water flow towards the other inverter);
- If one of the two motors shuts down or fails (engine OFF), the corresponding valve must be set to position “B” (the inverter now receives part of the cooling water from the operating gearbox flow).

Procedura operativa valvola a sfera 3 vie
3 Way Ball Valve Operating Procedure

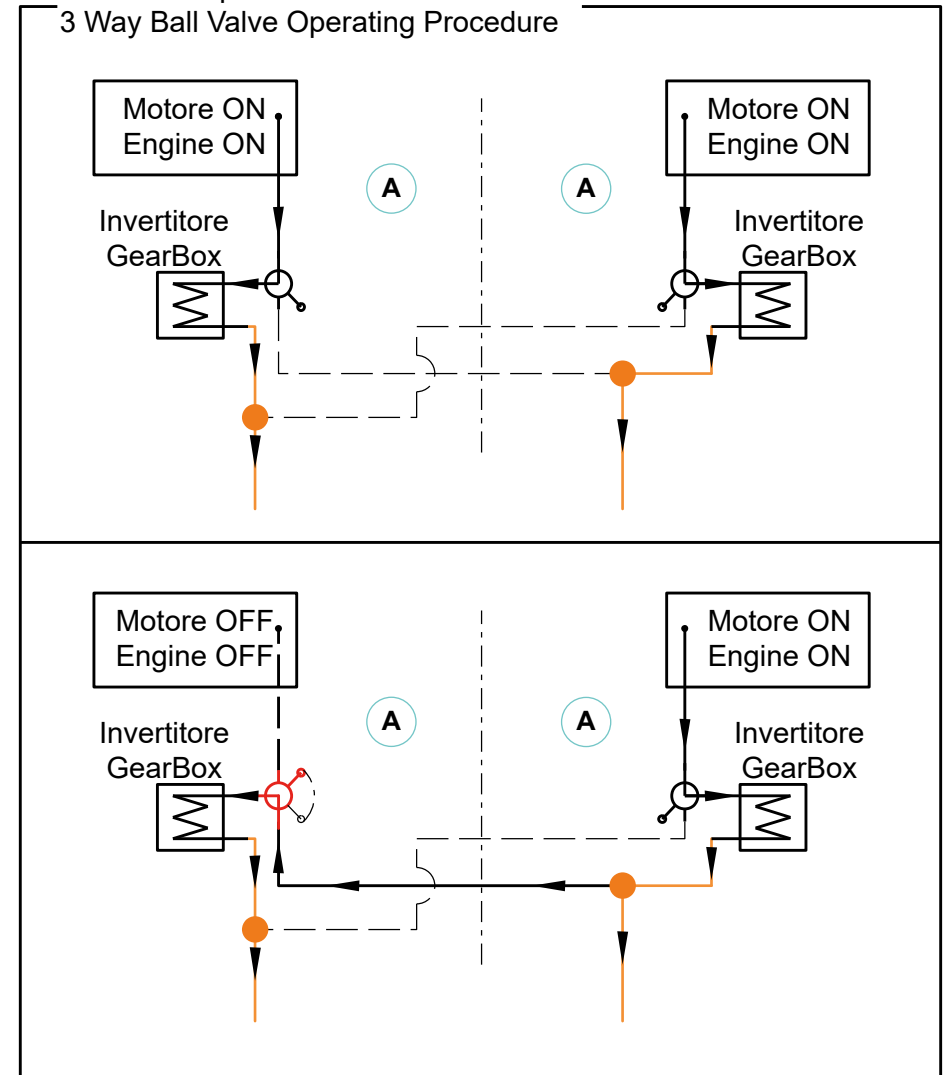

12.14 ENGINE EMERGENCY SUCTION FROM THE BILGE

In the engine room there is the bilge emergency draining system, which operates with shunters, which allow using the sea water pumps, driven by the propulsion engines as draining pumps.

The diverters are valves that in normal position ensure the suction of sea water cooling engines from the sea outlets and sea water filters. In case of emergency activate:

- The levers (4) to close the seawater suction;
- The levers (3) to open the bilge water suction.

The suction of the pumps, dragged by the motors, is then diverted directly into the bilge. If the need arises to use this exhaustion system, the bilge level must be checked continuously, as the engines will run out of cooling if exhaustion is complete.

1. Engine sea cocks
2. Bilge emergency suction sea cock
3. Bilge suction control lever
4. Sea suction control lever
5. Engine sea cock strainers



CAUTION

When the bilge is empty, remember turning the valves back to seawater intake position, in order to avoid damaging the engines.



CAUTION

In case of emergency it is possible to suck the water from the bilge through the sea water pumps of each engine.

Operating diagram:

Normal operation

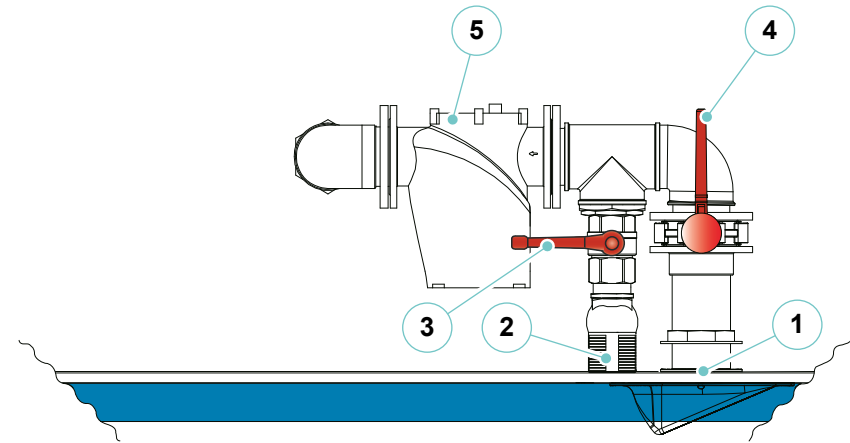

Emergency operation

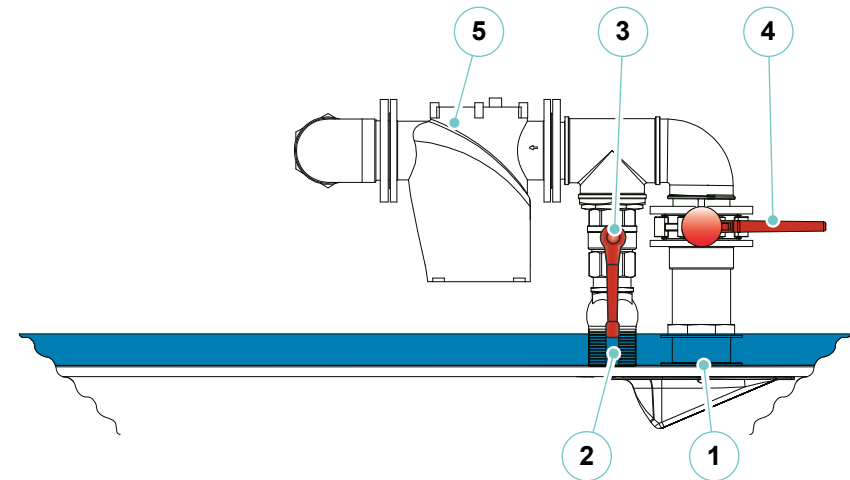

12.15 HAULAGE AND LAUNCH**CAUTION**

The lifting method depends on the type of the lifting equipment, therefore it cannot be suggested.

**CAUTION**

Before the haulage and launching operations, check that no foreign materials are on board, that all items are properly rigged and that nobody is on board.

**WARNING**

Hauling and launching operations have to be carried out only by skilled personnel and in qualified shipyards and under their direct responsibility. RIVA declines all responsibility for damage to property and harm to persons caused by the wrong performance of the hereunder listed operations.

- The lifting hoists must be in a good condition and particularly the lifting straps should not be worn out, and should be covered with suitable protections to preserve the bulwarks gel-coat and the bottom hull antifouling paint.
- The travel lift capacity must be greater than the yacht weight.
- If only one crane is available, use a “spacer” to give the lifting straps an angle greater than hull width.
- Test the stability before lifting the yacht, its centre of gravity depends on the load and its displacement..

**CAUTION**

Never place the lifting straps in the areas highlighted on the drawing.

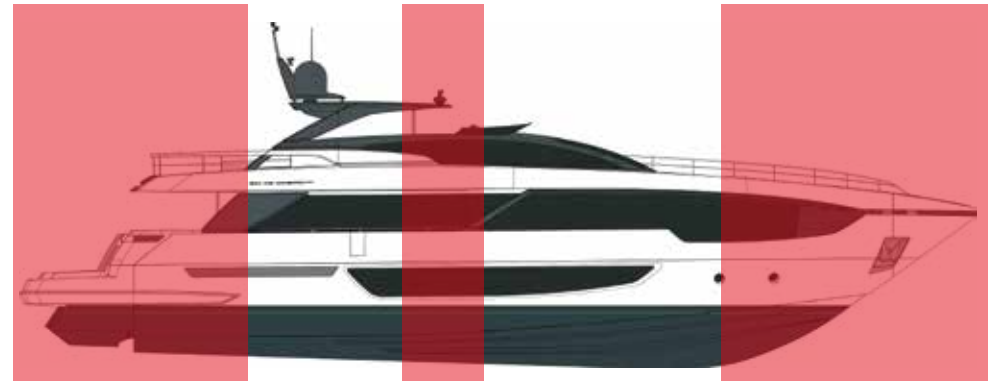

**CAUTION**

Do not put the lifting straps in way of intakes, of sea exhausts or of other protrusions.

Lifting straps must be positioned according to the loading conditions of the yacht at the moment of its lifting, because these vary remarkably, for instance, when the yacht is unloaded and dry or when the yacht is fully loaded. The lifting straps arrangement must be carefully evaluated each time, in order to prevent any damage to the yacht.

**CAUTION**

RIVA declines all responsibility for the location of the lifting straps, the lowering of the yacht to the ground and the support points carried out in other Shipyards.

**DANGER**

During haulage and launch, never stay underneath or in proximity of the yacht.

- When ashore, the yacht must be located on a cradle with five supports of width and size adequate to distribute the yacht weight evenly.
- The hull inclination must be as "natural" as possible, e.g. it must be parallel to the waterline and not to the keel. This to prevent that liquids on board keep a normal level and that rainwater can be drained naturally.

Cradles

RIVA is capable of providing the cradles for a correct support of the yacht (Optional on request). RIVA is not responsible for any damage resulting from the use of cradles different from those expressly produced by RIVA.

Propping

It is a common procedure to use supporting props if no actual storage capacities are available. It is very important to take some basic precautions while positioning the supporting props for the yacht in order to prevent damaging the hull structures, accidental falls of the yacht or injury to the involved personnel.

The following list contains useful advice. We also recommend always having propping operations carried out by experienced personnel.

- Use props with adequate strength and stability (each keel prop must support at least 1/5 of the whole weight of the yacht).
- Use correctly dimensioned supporting plates to prevent negative weight concentrations.
- Place the props preferably next to transversal structural reinforcements (stringers).
- Locate the props along the supporting fins of the hull.
- Always place at least 5 props along the keel, 3 props starboard and 3 props port in order to guarantee stability and weight distribution.
- Start by placing the 5 keel supports in a straight line, appropriately spaced to distribute the load.
- It is important that the props have the same height in order to prevent that the load is concentrated mainly on one of them.
- Have the yacht lowered very slowly until it almost touches the keel props, adjust the height of the props until they are in contact with the keel, in order to guarantee a uniform load distribution and a neutral trim of the yacht; keep part of the weight supported by the crane.

- Position the adequately spaced lateral props; it is important to remember that the lateral props must guarantee stability, but the whole weight must be supported mainly by the keel props.
- Check the support for stability, then completely lower the yacht and remove the belts.

The suggestions above are to be considered as being generally valid for propping the yacht without damaging it or harming the personnel involved; however, since the propping conditions may significantly vary depending on the props used and the surface on which the props rest, the above suggestions must be adapted case by case. RIVA is therefore not responsible for any damage to the yacht occurring while the yacht is at dry shore on props.

12.16 DRAWING THE YACHT IN CASE OF FAILURE (OR TOWING)

In case the yacht needs to be drawn or towed, fasten the towing lines as shown in the figure, in order to distribute the load evenly and pull in the middle. It is a good rule, after fastening the cleats, to carry on with the rope, and the winch: so as to load the strongest yacht's points only.

The towing rope length depends on the sea conditions, and must be adjusted in such a way to limit the pulling forces without damaging the deck fittings.



DANGER

Do not approach and do not carry out any kind of intervention on transmission during the towing because propeller can turn.



WARNING

If towing is necessary, it is only possible with a flat sea and calm wind and only for towing vessels with a displacement of no more than 50% of that of your boat; in an emergency, if towing is not possible, come to the rescue by taking on board the people of the other vessel, as far as foreseen and possible, and reach port.

Anyway, inform immediately the Port Authority.



**WARNING**

Towing navigation can be carried out continuously for 8 hours, provided that you constantly monitor the gear box oil temperature, which must not exceed 80°C.

If temperature exceeds 80°C, stop navigation and wait until temperature lowers.

When the engine is shut OFF, the throttles position is unimportant.

**CAUTION**

It is the Owner's/the operators' responsibility to make sure that the mooring ropes, the towing ropes, the anchor chain(s), the anchor lines and the anchor(s) are suitable for the intended use of the yacht, i.e. the resistance of the ropes or chains must not exceed 80% of the resistance to breaking of the relevant strength point.

The Owner should also determine which action is necessary when fastening a towing rope on board.

**CAUTION**

Always draw other yachts or let your yacht be towed at low speed. Never exceed the speed of the drawing yacht when you are being towed.

**CAUTION**

Fasten your yacht to a towing rope so that it can be released when loaded.

**CAUTION**

Do not stand near the ropes during drawing (or towing) operations, a rope that breaks can be extremely dangerous ("whip lash effect").

**DANGER**

During towing navigation, the propeller shaft has to be kept turning by the water flow through propeller. We recommend not to carry out any kind of service on the propulsion devices (engines, gear boxes, shafts, etc..).

12.17 BOAT STEERING RULES

Yacht in sight

We can consider three ways of encountering another yacht on the water:

- Meeting
- Crossing
- Overtaking

Normally, the yacht with less manoeuvrability has the right-of-way.

Stay clear of the yacht and pass to his stern. The yacht, that has the right-of-way, is called the “privileged yacht”. This yacht can maintain speed and course. The “burdened yacht” is the yacht, which must adjust her course and/or speed as required to keep clear of the privileged yacht.

Meeting

When meeting another yacht proceeding on a parallel course, both boats shall adjust the speed accordingly and keep her course.

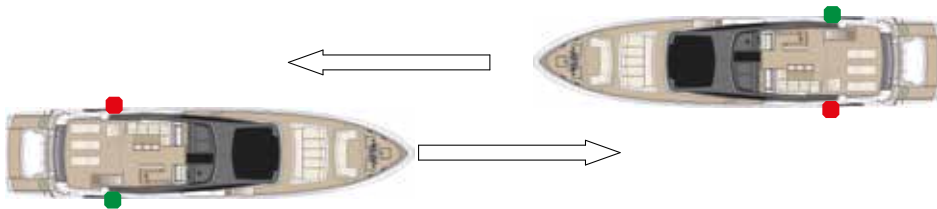

When two power-driven yacht are meeting on reciprocal or nearly reciprocal courses so as to involve risk of collision each shall alter her course to starboard so that each shall pass on the port side of the other.

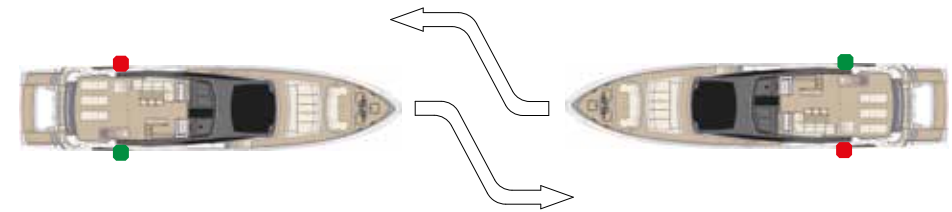

Crossing situation

When two power driven boats are crossing so as to involve risk of collision, the yacht which has the other on the her own starboard side shall keep out of the way and shall, if the circumstances of the case admit, avoid crossing ahead of the other yacht.

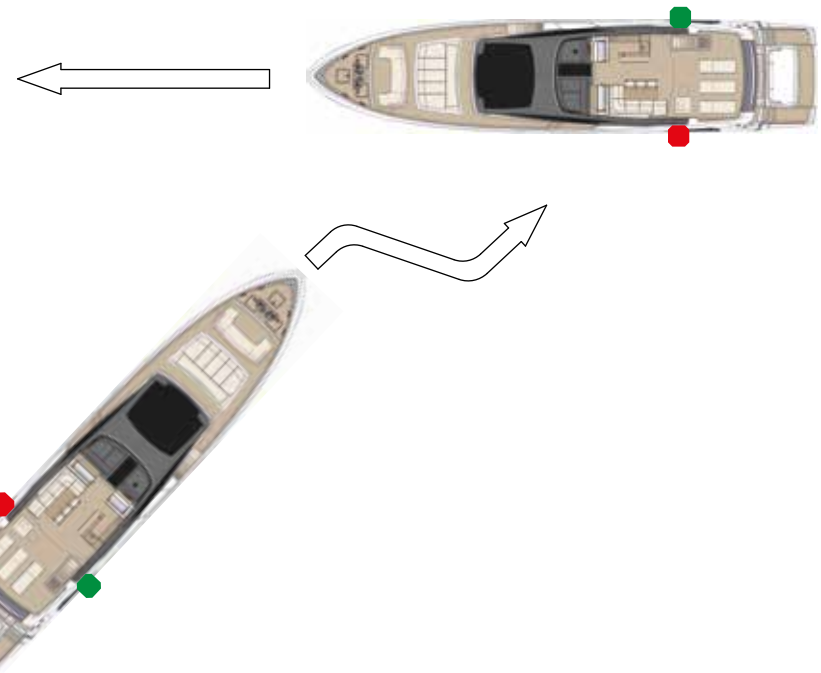

Overtaking situation

An overtake is defined as when one yacht comes from a direction of over 22.5 degrees aft, with respect to the yacht that it intends to overtake, in order that the stern lights can be seen but none of the side lights.

If you find yourselves overtaking a slower yacht, which is in your path travel, you are the burdened yacht. Make any adjustment necessary to avoid collision and pass either to port or starboard. Signal your intent to do so by sounding your horn twice if passing on the port and once if passing on the starboard.

The yacht being overtaken by another, has priority over the last and therefore must maintain the same course and speed without pulling over and manoeuvring.

It is considered to reaching the yacht that has the bow inside the angle of 135°, formed from the yacht's stern light that is reached.

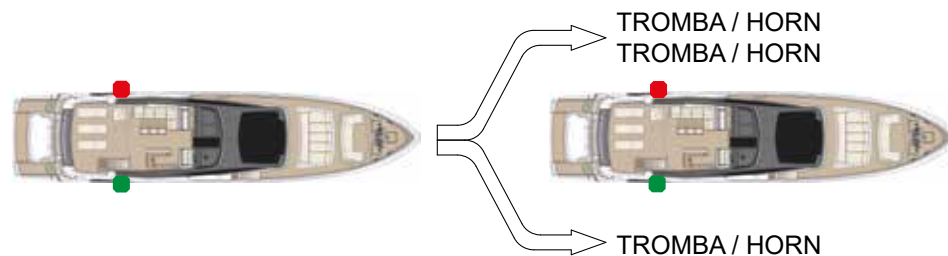

Riva

102 CORSARO *supera*

Riva

102 CORSARO *supera*

HULL AND FURNITURE MAINTENANCE

CHAPTER 13

13.1 GENERAL MAINTENANCE OUTLINES

The yacht is equipped with a large number of sophisticated devices and systems, which require not only a certain care when it comes to use, but also regular maintenance to obtain correct operation.

One of the factors that might cause problems or faults, is usually the irregular use of the yacht and because of this, of the on-board devices.

Experience indicates that regular use of the devices normally gives fewer problems, and therefore, we recommend operating all on-board devices regularly, for short periods.

Daily checks and regular maintenance are important for maintaining equipment/components in the best working order and efficiency.

If the regular maintenance schedule is not correctly followed, the equipment's performance can deteriorate, causing reduced efficiency, a shorter life and the occurrence of unexpected problems which can compromise safety at sea.

The maintenance schedule is based on time intervals or running hours. For example, if a maintenance task is scheduled every 100 hours or 3 months, this task must be repeated at 200 hours or after 6 months, at 300 hours or after 9 months, and so on.

In case of a long period of inactivity (for example, during winter), it is advisable to lay up the yacht, possibly under cover.



CAUTION

Some general information about ordinary maintenance tasks, their schedule and procedures is provided herein with.

For further specific information referring to maintenance schedule, see Manufacturer Manuals of on board devices/components, issued by the various Manufacturers.



CAUTION

Look over the maintenance safety rules contained in this manual in order to act with the maximum safety and follow the indications here below.



CAUTION

During the replacements, remove the parts with care and order, in this way the assembly operations are as easy as possible.

Make sure to install genuine spare parts, in this way the system efficiency is not altered.

Sometimes the use of non-genuine spare parts may cause the withdrawal of the Manufacturer's warranty.

**CAUTION**

Check periodically that all equipment containing water is filled with the correct quantity of anti-freeze.

If the outside temperature drops below 0°C, all fresh or sea water systems are exposed to the risk of freezing and consequent breakage.

Systems especially subject to risks of freezing are all systems and devices containing either fresh or sea water.

**WARNING**

Before carrying out any maintenance and adjustment operation on the yacht, turn all necessary safety devices on and consider informing all personnel, in particular persons operating nearby. In particular, place warning signs in the areas concerned and prevent any device, if operated, from causing unexpected hazardous conditions, thus endangering the persons on board and/or property.

To avoid pollution, do not scatter any type of waste in the environment, and only use the dedicated disposal areas in the harbours.

**CAUTION**

When working in the engine room, switch magneto-thermal switches of the bilge draining pumps off, to prevent that fuel, lubricants and other liquid spilling causes sea pollution.

**CAUTION**

RIVA declines all responsibility for the installation and operation of electric, electronic or mechanical equipment improperly installed by third parties in a manner not authorised by the Shipyard.

RIVA declines all responsibility with regard to tampering carried out by third parties on equipment installed in the Shipyard. Such tampering or unauthorized installations will not only immediately void the warranty, it may also cause damage to the yacht and injuries to the people on board. RIVA declines all responsibility concerning regular maintenance operations scheduled by the Shipyard or by Manufacturers, but not carried out, on equipment/components, for which it is necessary to refer to the relevant Technical Manuals.

**CAUTION**

The use of pressurised water on outdoor light equipment is forbidden.

13.2 LONG PERIODS OF YACHT INACTIVITY

Following list only represents a general guide to give the customer an idea of the ordinary maintenances which should be carried out when the yacht remains stationary for a rather long period without being used. We recommend carefully checking the instruction manuals of the single devices, because they often contain detailed information and very important specifications relevant to the maintenance of each device.

The following instructions NEVER REPLACE the specific instructions concerning each single device and issued by the device's Manufacturer.

- **Engines**

Before winter time let fresh water flow into the sea water circuit, check the antifreeze liquid, the sacrificial anodes against the galvanic currents, remove salt build-ups and spray protective agents.

Carry out the scheduled maintenance of the propulsion engines, indicated in the Use and Maintenance section.

- **Generators**

Use the same procedure as for the engines.

- **Inverters**

Carry out the scheduled maintenance for gear boxes.

- **Batteries**

Check the liquid level and regularly charge the batteries, protect the terminals with Vaseline grease; the best solution would be to disconnect the batteries from the system and to charge them regularly with a separate battery charger, but this is not always possible on yachts.

- **Watermaker**

A proper procedure provided by the supplier in the instruction manual has to be followed when the watermaker is not used for a long time.

- **Washers and Dishwashers**

Carry out an empty washing cycle, carefully remove all detergent residues, and dry thoroughly. Clean the filters.

- **Sun-deck cushions**

Remove all sun-deck cushions and store them into a dry place.

- **Aluminium and steel**

Wash all metallic parts with fresh water and protect by rubbing with a rag soaked into Vaseline oil.

- **Wood and interior upholstery**

Cover the cushions of sofas with sheets and above all cover all windows with the relevant covering sheets, so that as little light as possible is projected inside, because the UV rays fade the wood and tissue colours.

- **Teak wood deck**

Wash with water and neutral soap and treat with proper products. Sandpaper if strictly necessary.



CAUTION

DO NOT USE mechanical or forced water jet equipment (e.g. pressure washers, etc.) to wash the deck, as this force alters the wood and the caulking sealants (it detaches the microparticles) causing damage in some cases even radical (e.g. detachment of the staves).



CAUTION

DO NOT USE alkaline-based or acid-based detergents or aggressive detergents (soda, solvents, ammonia, etc..) to wash the deck; their aggressive degreasing action corrodes the wood (it eliminates its natural water repellency and whitens its natural colour), while the caulking sealant modifies its physical-chemical qualities, softening the surface, damaging the waterproofing, sealing and anchoring of the deck.

- **Sacrificial anodes**
Check their wear and if necessary, replace the hull, propellers shafts and interceptor anodes, etc.
- **LOG Transducer**
Pull out the propeller, clean it and apply the proper propeller plug.
- **Windscreen wiper**
Wash with fresh water and lubricate with Vaseline oil.
- **Anchor winch**
Protect the electrical components with a suitable protective spray and lubricate with silicon grease clutches and wildcat.
- **Water tank**
Wash with disinfectant, drain the fresh water circuit, especially if frost is forecasted.
- **Fuel tank**
Cleaning by means of a decanter especially if there are traces of water in the fuel.
- **Grey water tank**
Pour sterilizing products into the washbasin, showers, and bidet wastes . Empty the tank and clean, ensuring the float is efficient.
- **Black water tank**
Pour a sanitary product containing Paraformaldehyde (available in camping equipment shops) into the WCs and rinse the tank with this mix a couple of times. Drain the tank completely.
- **Air conditioning**
Before winter:
 - Let water flow in the sea water system.
 After winter:
 - Check the anti-freeze mix in the fresh water circuit: top-up or replace it if necessary (perform replacement at least every two seasons);
 - Carry out the maintenance operations suggested by the Manufacturer.
- **Tender engine**
Wash with the fresh water contained in the cooling system of the engine. Carry out the maintenance as recommended by the supplier.
- **Bow and stern thruster**
Protect the electrical components with a proper spray and check the oil level.
- **Electro-hydraulic control units**
Protect with the proper sprays and check the oil level.
- **Fire extinguishers**
Check the loading condition and expiry date for regular inspections.
- **Safety equipment**
Check the expiry dates of the self-inflatable means, flares etc..
- **Refrigerators**
Cleanliness for all and protection for those outside in case the yacht remains open air.
- **Engine room**
As for the engine room, we suggest carrying out a general cleaning, by removing all traces of salt drifts on devices and protect all electric, mechanic and hydraulic devices, by spraying them with protective agents.
- Clean all cabins and inspect all dunnages on-board.
- Check all hatches seals and lubricate their contact with appropriate silicone lubricant.
- Clean fan coils with an air jet, sucking the dust from the back net.
- Inspect the outer hull and all components: propeller, anodes, supports, interceptors, fan coils, sea cocks, bow/stern thruster.
- Carry out laying up of the yacht in a sheltered and dry place. If the yacht is stationed outside, cover it with a waterproof sheet, in such a way that allows ventilation. Otherwise the formation of damaging moisture could be helped.
- Wash the yacht with fresh water.
- Check all systems and fastenings on the yacht: damages, wear, cracks are signs of unsuitable use. Repair the damaged equipment. If necessary, fit new ones.
- Check the efficiency of limber holes and that they are not clogged so as to cause the leaking of the bilge system.
- Check the fastening of the partial or total covering of the yacht.
- Disconnect all unnecessary utilities.

**DANGER**

During recharge the batteries produce explosive gas. Do not approach to recharging area with free flames or sparkles.

Avoid wrong connections; never connect a positive terminal (+) with a negative one (-).

13.3 RE-USE OF THE YACHT AFTER A LONG INACTIVITY**Engines**

After the winter, check engines oil, gear boxes and replace them if necessary. Check oil and fuel filters and replace them if necessary.

- Adjust the belt tension of the alternator belts both of engines and generators.
- Fill the fuel tank. Vent the air of the fuel system.
- Start propulsion engines.

**CAUTION**

After a long period of yacht inactivity, carry out all above-listed operations and following checks:

- Check the condition of all hoses and connections of the steering system, interceptor, gangway, swim ladder, etc.
 - Start the engines.
 - Stop the engines.
 - Clean fuel filters. Replace engine oil filters and add oil to the engines if necessary.
 - Check all bilge pumps and their operation.
 - Check the operation of the black water, grey water and sea water pumps.
 - Check the operation of all on-board instruments used for navigation.
-
- Let the engine run at middle speed for some minutes, before letting them run at full speed.

Generator:

- Start the engine of the power generator.

Hull:

- Verify the hull.
- Have the bottom hull accurately cleaned, as well as the rudders and interceptors with brushes (with water) or a jet-cleaner (dry) to remove seaweed and scales.
- Check the paintwork condition of the hull. If necessary, have 2 coats of suitable antifouling paint applied by specialized personnel.



Propellers and anodes:

- Verify the propeller condition and possible leaks from the seals, if necessary adjust them.
- Check the conditions of the sacrificial anodes; if necessary, replace them.

Batteries:

- Check the charge of the batteries, and that their terminals and housings are dry and clean.

13.4 HULL MAINTENANCE

Component	Maintenance	Notes and precautions
Bottom hull	<p>Periodical cleaning and check of antifouling treatment (as required according to stationary area, but at least every three months)</p> <p>Check/restoration</p> <p>Preparation of the surface of an already treated yacht</p>	<p>The length of the anti-fouling effects depends mainly on the conditions of the waters where the yacht is stationed.</p> <div data-bbox="880 443 2074 671" style="border: 1px solid yellow; padding: 5px;"> <p style="text-align: center;"> CAUTION</p> <p>When removing the old antifouling, do not use sandblasting methods, as this may damage the gel-coat surface and the anti-osmosis resin applied by the Manufacturer. As suggested by the antifouling manufacturers, use paint removers or, as an alternative, wet sanding.</p> </div> <p>The Shipyard uses high-quality ant-fouling paint and applies two layers.</p> <div data-bbox="880 786 2074 979" style="border: 1px solid yellow; padding: 5px;"> <p style="text-align: center;"> CAUTION</p> <p>Bad maintenance condition (barnacles, etc..) may cause cavitation and damage shaft, rudders, propellers, etc..</p> </div> <div data-bbox="880 1026 2074 1182" style="border: 1px solid yellow; padding: 5px;"> <p style="text-align: center;"> CAUTION</p> <p>Small areas of paint may peel off from the propellers even after a short period of operation.</p> </div>

13.4.1 Bottom hull

Antifouling treatment

If scales build up on the hull, this causes notable speed reduction and with time may damage the “gel-coat”. When you choose an antifouling paint for your yacht, it is important that you find the proper product, suitable for your yacht and for the waters in which you are going to navigate. Contact the RIVA After Sales & Service Department.

Check/restoration

The cleaning and checks have to be carried with yacht at dry shore or with the help of a diver. Have the repairs done only with yacht at dry shore.



WARNING

To clean or check the yacht in water, disable engines and generators ignition.



CAUTION

There are some hull areas (fastening area of thrusters shaft support base, submerged drainage areas, around the thruster tunnel and shaft exits, etc.) where operations can be carried out after hull pressing; in these areas, fillers are usually used which, over time, may produce local faults, like bubbles or small cracklings. These little faults do not impair the hull's mechanical strength at all. To repair them just sandpaper the area, remove the bubbles, and apply fillings suitable for the bottom hull.

- Have the bottom hull accurately cleaned, as well as the rudders and flaps with brushes (water) or a jet-cleaner (dry) to remove seaweed and scale.
- Check the paintwork situation of the bottom hull. If necessary, have 2 coats of suitable antifouling paint applied by specialised personnel.

Preparation of the surface of an already treated yacht

Carefully check the old anti-fouling paint to see if it is still good or if it needs a new layer. Make sure that the new product is compatible with the old one. Contact the RIVA After Sales & Service Department. If the old antifouling is crusty, thick and tends to scale off, then remove it and start the treatment as for a new yacht.



CAUTION

Antifouling is poisonous and should never be burnt, use only authorized disposal procedures and in case of doubts contact the authorities in charge. The sandblasting operations and removal of antifouling must be carried out with suitable clothes and protections.







WARNING



During the application of antifouling, make sure that following parts of the bottom hull are not painted:

- Depth sounder transducer
- LOG speed sensor propeller
- Sacrificial anodes
- Shafts and propellers.
- Underwater lights;
- Hull porous plate.



13.5 GENERAL MAINTENANCE

Component	Maintenance	Notes and precautions
<p>Gel-coat</p> <div data-bbox="107 408 477 775" style="border: 1px solid black; padding: 5px;">  <p>CAUTION The alteration of colour and brightness in areas which are highly exposed is considered normal. The necessary polishing has to be considered as normal maintenance.</p> </div> <div data-bbox="107 820 477 1225" style="border: 1px solid black; padding: 5px;"> <p>MAINTENANCE At least once a month carefully clean all fibreglass parts. At least once every six months check the status of the fibreglass. When necessary, but at least once every two years, polish all fibreglass parts.</p> </div>	<p>Formation of bubbles Regular cleaning (as required)</p> <p>Formation of cracks Regular cleaning (as required)</p>	<p>In some areas of the yacht, bubbles may form on the gel-coat; these bubbles can break over time, thus exposing the fibreglass underneath. The drawback occurs generally in vicinity sharp angles, and depends on air bubbles that, during fabrication, remain entrapped between fibreglass and gel-coat, although quality checks are carried out by specialised personnel. Broken gel-coat bubbles are easy to repair by filling the voids and touching up with gel-coat that can be requested from the Service Department.</p> <div data-bbox="880 584 2074 775" style="border: 1px solid black; padding: 5px;">  <p>CAUTION Always wash using neutral products. In case of particularly persistent dirt, do not use products containing ammonia which can turn the surface yellowish.</p> </div> <p>When underway, some structural parts of the yacht are subject to bending, and create tension or compression stresses in fibreglass and on the gel-coat; the different elasticity of gel-coat and fibreglass can cause small cracks on the gel-coat surface, in particular in the most stressed areas, e.g., near cleats, stanchions, etc. This problem, however, does not jeopardize the mechanical and structural characteristics of fibreglass.</p> <div data-bbox="880 1034 2074 1257" style="border: 1px solid black; padding: 5px;">  <p>CAUTION To remove possible gelcoat, do not use sandblasting methods that may damage the surface of the anti-osmosis resin applied and could expose fibres. As suggested by gel-coat Manufacturers, use suitable products or, as an alternative, wet sand.</p> </div>



Component	Maintenance	Notes and precautions
Wood and upholstery	Regular cleaning	<p>The worst enemies of these materials are light and moisture; to protect them, they must be kept away from direct light as much as possible and the interior must be ventilated as soon as the weather conditions allow. The use of external awnings is extremely important because there is no species of wood, either natural or dyed, which, when exposed to the sun's rays, does not undergo a change in colour.</p> <p>The woods used for the yacht's fittings are exclusively natural-based materials carefully selected and the painting cycles with which they are treated comply with environmental regulations. Furniture made of wood, precisely because of the natural origin of both the material and the treatments, may be subject, if not properly treated and maintained, to:</p> <ul style="list-style-type: none"> • Colour variations due to exposure to direct and continuous light. It is advisable to shade the heavily exposed parts with the internal curtains supplied with the yacht; • Retention of dirt if not cleaned promptly, given the characteristic absorbency of wood fibres. It is recommended to use non-aggressive products; • Scratches and marks if in contact with sharp or metallic objects, due to the inevitable relative "softness" of the wood. <p>Even if the production processes have been carefully studied and tested, the furnishings and fittings made of natural wood may undergo variations in colour over time due to the "natural" maturation of the material due to ageing.</p> <p>Despite the painting cycles developed after many years of experience, wood remains a "living" material, and therefore subject to movement and settlement. Scratches caused by bumps must be repaired immediately, to avoid the blackening of the wood below. The technical staff of the RIVA After Sales & Service Department will advise you about the maintenance level you have to apply at the end of each season's use. Correct maintenance will allow you to avoid deterioration which is expensive to repair.</p> <div style="border: 2px solid yellow; padding: 10px; margin-top: 20px;"> <p style="text-align: center;"> CAUTION</p> <p>The extremely precious finishes of the polish-varnished woods used for bathroom floors and cockpit tables is the result of careful work: they are water resistant but at the same time delicate and need careful maintenance. Such surfaces must therefore be dried after use or after rain and must be washed and maintained regularly.</p> </div>



Component	Maintenance	Notes and precautions
Wood and upholstery	Regular cleaning	<div data-bbox="880 264 2074 528" style="border: 2px solid yellow; padding: 10px;">  <p>CAUTION</p> <p>Upholstery and wooden parts: the leather and wooden parts have to be treated as natural products, subject to colour alteration, particularly if the necessary precautions for good maintenance are not taken. RIVA therefore reserves the right to evaluate any problems and its own responsibility according to case.</p> </div> <div data-bbox="880 571 2074 695" style="border: 1px solid gray; padding: 10px; text-align: center;"> <p>MAINTENANCE</p> <p>At least once a week, carefully wash and clean all teak outside parts, and at least once a year perform a protective treatment with suitable products.</p> </div> <div data-bbox="880 738 2074 1286" style="border: 2px solid yellow; padding: 10px;">  <p>CAUTION</p> <p>Current use:</p> <ul style="list-style-type: none"> • Do not walk or jump on the cushions; • Prevent the cushions from turning yellow due to direct exposure to sunlight; • Prevent the absorption of water or moisture by not leaving the upholstery exposed to bad weather, particularly during periods of inactivity. <p>Cleaning:</p> <ul style="list-style-type: none"> • Remove ordinary dirt with a warm water solution and neutral soap: do not use detergents or solvents; • Dry with a soft rag, not leaving any residues. <p>Preservation:</p> <ul style="list-style-type: none"> • Store clean and dry upholstery in a cool, ventilated room with no moisture; • Do not place heavy objects on upholstery when stored. </div>



Component	Maintenance	Notes and precautions
Teak	Regular cleaning	<p>The characteristic of teak is its resistance to weathering and therefore, it does not require maintenance. Over time, teak tends to assume a particular silver colour that may not appeal; in this case, to maintain the original colour of the teak, it needs to be treated regularly with specific products (e.g. teak wonder).</p> <p>If the wood has smears that cannot be removed with normal washing, it is necessary to sand the wood to remove stains, and then repaint with wonder teak.</p> <p>You must use fresh water and manual brush (no hard bristles) at least once a day. This will remove any machinery, common dirt from feet and shoes, and normal environmental salt. This process, if carried out regularly, allows constant maintenance of your teak and caulking. In this case only time and wear will naturally deteriorate this product.</p> <div style="border: 2px solid yellow; padding: 10px; text-align: center;">  <p>CAUTION</p> <p>Do not clean the teak with stiff brushes, as even rubbing the grain lengthways can damage the softer grain of the wood.</p> </div> <p>Non-black caulking may not behave in the same way as the black one. Any aesthetic issues, such as surface mildew, colour variations, dirt in the caulking are not defects and may be prevented with regular maintenance and service on the teak surface and caulking.</p>

Component	Maintenance	Notes and precautions
Teak	Regular cleaning	<div data-bbox="878 264 2069 740" style="border: 2px solid yellow; padding: 10px;"> <p style="text-align: center;"> CAUTION</p> <p>Washing the deck with mechanical equipment or with a jet of pressurised water (hydro-cleaners, for example) IS STRONGLY ADVISED AGAINST since this force alters the wood and the caulking sealants (detaches the micro-particles), even causing serious damage in some cases.</p> <p>Washing the deck with alkaline or acid-based detergents, or however with aggressive agents (soda, solvents, ammonia, etc..) IS STRONGLY ADVISED AGAINST. Their aggressive degreasing action corrodes the wood (eliminates its natural water-repellent properties and bleaches its natural colour), while the physical-chemical properties of the caulking sealant are altered, with its surface portion becoming softened and the impermeability, sealing and anchorage of the deck becoming damaged.</p> </div> <div data-bbox="878 785 2069 1294" style="border: 2px solid yellow; padding: 10px; margin-top: 10px;"> <p style="text-align: center;"> CAUTION</p> <p>Be careful when cleaning the exterior painted parts. The use of alkaline or acid-based soaps or detergents, which are usually used to remove dirt or salt, can settle on the deck and irreparably damage the teak and caulking sealant.</p> <p>Therefore, teak and caulking sealant must be insulated when these washes are carried out. Therefore, when these washes are carried out, it is necessary to isolate the teak and caulking sealant from any deposits, even temporary, of soaps and/or detergents. If it is not possible to cover the deck when cleaning the fibreglass, we recommend wetting the deck surface with plenty of fresh water.</p> <p>We recommend the same procedure when refuelling.</p> <p>If fuel seeps into the wood or caulking sealant, the deck will be irreparably damaged there. Use a neutral detergent to clean the teak.</p> </div>

Component	Maintenance	Notes and precautions
Ceilings Panels	Regularly check the flatness of the panels and / or any discontinuities or steps between the ceiling panels	<p>Whenever the ceilings are disassembled, it is compulsory to check the status of the Fit Lock or/ and 3M Dual Lock fastening systems, breakage of the teeth, and/ or the entire system.</p> <div style="border: 2px solid orange; padding: 10px; margin: 10px 0;"> <p style="text-align: center;"> WARNING</p> <p>Do not install Fit Lock or 3M Dual Lock ceiling panels with damaged fastening systems , due to a possible reduction of their retention power. Damaged parts must absolutely be replaced with new ones.</p> </div> <p>In order to be sure that the ceilings have been reassembled correctly, check flatness with the other ceiling panels and the absence of discontinuities and steps between one ceiling panel and the others.</p>

Component	Maintenance	Notes and precautions
Light alloys and stainless steel	Regular cleaning	<p>It is a good rule to accurately wash the entire yacht after each navigation, in particular all metal parts that may be damaged by sea water. Have plenty of fresh water sprayed on handrail, windows, skylights, rub rail, anchors, cleats and ladder. Protect all metal parts with Vaseline oil periodically.</p> <div data-bbox="880 435 2074 523" style="border: 1px solid black; padding: 5px; text-align: center;"> <p>MAINTENANCE At least once a year check the fastening of all metallic parts of the yacht.</p> </div> <div data-bbox="880 568 2074 759" style="border: 2px solid yellow; padding: 10px; text-align: center;"> <p> CAUTION The stern glass door is not watertight, so do not point the bolt of water towards the window, when washing.</p> </div> <div data-bbox="880 804 2074 995" style="border: 2px solid yellow; padding: 10px; text-align: center;"> <p> CAUTION Never use brushes or abrasive rags on metallic fittings, not even on rusty spots, scratches on the surface result in a less shiny appearance and diminish the mechanical features.</p> </div>

Component	Maintenance	Notes and precautions
Windscreen/windows	Regular cleaning	<div data-bbox="882 268 2074 496" style="border: 1px solid yellow; padding: 10px; margin-bottom: 10px;"> <p style="text-align: center;"> CAUTION</p> <p>Rags and chamois leathers used for cleaning glass must be replaced at least every 3 months. The inner side of windows and windscreen can be cleaned with non-aggressive and non- acid detergents for glass and a soft or paper cloth.</p> </div> <div data-bbox="882 539 2074 767" style="border: 1px solid yellow; padding: 10px; margin-bottom: 10px;"> <p style="text-align: center;"> CAUTION</p> <p>If, after normal cleaning, some traces of dirt or light scratches remain, do not try and remove them with mechanical means or using aggressive detergents, solvents or abrasive products. Contact the Service Department.</p> </div> <div data-bbox="882 810 2074 1286" style="border: 1px solid yellow; padding: 10px;"> <p style="text-align: center;"> CAUTION</p> <p>For cleaning the outer side of coloured or mirrored (pyrolytic) windows and windscreen:</p> <ul style="list-style-type: none"> • Evenly wet the whole surface of the glass with plenty of fresh water. • Use a neutral detergent or a delicate commercial product (not alkaline) diluted in fresh water. • Spread the solution with a soft and clean cloth. Frequently rinse the cloth in order to prevent deposits of dust or dirt particles which could scratch the glass or its glazed coating. • Rinse the soapy surface with plenty of fresh (or distilled) water. • We recommend drying the glass with chamois leather only. <p>For cleaning the tinted windows and windscreen it is possible to use the same type of detergent used for internal cleaning (non-aggressive and non-acid).</p> </div>

Component	Maintenance	Notes and precautions
Mirrored glass walls	Regular cleaning	<div style="border: 2px solid yellow; padding: 10px; text-align: center;">  <p>CAUTION</p> <p>For cleaning mirrored glass walls only use water and neutral soap. Different products could damage the surface coating.</p> </div>
Windscreen wiper and washer	Regular cleaning (as required)	<p>Wash them carefully with fresh water and coat with Vaseline oil; grease the spring with silicone grease.</p> <p>Check the rubber blade conditions regularly, and replace the blades if worn; this prevents bad visibility problems.</p>
Windscreen and deckhouse glass	Inspection of seals	<div style="border: 2px solid yellow; padding: 10px; text-align: center;">  <p>CAUTION</p> <p>At least once every 6 months check the condition of the glass seals. If you feel that the seals have deteriorated due to a wear, please contact our Service Department.</p> </div>
Light fittings	Regular cleaning	DO NOT use alcohol-based products to clean the light bodies.

Component	Maintenance	Notes and precautions
Instrumentation and navigation lights	Regular cleaning (as required)	<p>Use clean wet rags for cleaning.</p> <div style="border: 1px solid black; padding: 5px; margin: 5px 0;"> <p style="text-align: center;">MAINTENANCE</p> <p>At least once a week, check the operation of the navigation lights. At least once a week, carry out careful cleaning of glasses and headlights. At least once every six months, check the presence of corrosion in the connections of the navigation light cables. At least once every six months, tighten the cable connections of the navigation lights.</p> </div> <div style="border: 2px solid yellow; padding: 10px; margin: 5px 0; text-align: center;">  <p>CAUTION</p> <p>Do not use chemical or abrasive products.</p> </div> <p>After navigation, cover instrumentation and equipment.</p>
Metal parts and connectors	Regular cleaning (as required)	Grease connectors and metal parts of the devices installed and exposed to moist and salty environment to prevent oxidation; pay particular attention to the above-mentioned components of the steering system, gangway, hatches, and control units, etc..

Component	Maintenance	Notes and precautions
Plexiglass	Regular cleaning (as required)	<p>To clean the Plexiglass, only use products that do not contain aggressive substances such as alcohol, ammonia or the like. Preference for antistatic liquid detergent.</p> <div style="border: 2px solid yellow; padding: 10px; text-align: center;">  <p>CAUTION</p> <p>Never use alcohol or acetone to clean Plexiglas parts; they could crack inside.</p> </div> <p>Use cloth of soft material (such as cotton or felt) To clean, degrease and polish the Plexiglas, spray a small amount of antistatic liquid detergent on the cloth and wipe the surface. The antistatic effect of the cleaner is very useful to prevent dust from being attracted by static electricity generated during rubbing and that makes it very difficult to clean the entire surface smoothly. If the cause of opacity is dirt, simply use an anti-static cleaning fluid and a soft cloth to remove smears: the Plexiglas will clean and bright. If opacity is due to the contact with aggressive substances, it means that the surface has been compromised in the structure and the Plexiglas will not return as before. If the marks are light and have been caused by wear and not from chemicals, anti-scratch paste can solve the problem. Even for light scratches anti-scratch paste is suitable.</p>

Component	Maintenance	Notes and precautions
Shower	Checking and replacing gaskets	<div data-bbox="1357 288 1447 368" style="text-align: center;"> </div> <p data-bbox="1462 347 1599 373" style="text-align: center;">CAUTION</p> <p data-bbox="893 384 2063 448">Carry out regular maintenance and/or replacement of the shower box seals, in order to prevent water leakage.</p> <hr/> <div data-bbox="1357 491 1447 571" style="text-align: center;"> </div> <p data-bbox="1462 550 1599 576" style="text-align: center;">CAUTION</p> <p data-bbox="893 587 2063 651">The shower enclosures are made in such a way as to avoid water leaks outside the enclosure, under normal conditions of shower use. However, they do not have a watertight seal.</p> <div data-bbox="1151 691 1805 1166" style="text-align: center;"> </div> <p data-bbox="893 1235 2063 1299">The functionality of the shower cubicles is subject to the use for which it was designed; the water tightness is therefore conditioned by the correct use.</p>

Component	Maintenance	Notes and precautions
Fenders	Regular cleaning (as required)	Always keep all the fenders and their sleeves clean by washing regularly with fresh water, in order to prevent the salt deposited on them from scratching the paint of the hull.
Back glass wall	Cleaning	<p>The stern glass wall has many functional and aesthetic advantages. The salon door, that completely overlaps the fixed part starboard makes it possible to convert the salon and the cockpit into a single, large room. Of course, this glass wall needs particular care during washing, because a lack of care may allow water to penetrate. To avoid this problem, we advise taking great care to the direction of the water jet for rinsing: it should not be directed frontally and with pressure, but the water should be let flow down from above.</p> <div style="border: 1px solid black; padding: 5px; margin-top: 10px;"> <p style="text-align: center;">MAINTENANCE</p> <p>At least once a week, clean thoroughly. At least once a month, check the operation. At least once every six months, check the locking with open door. When necessary have them adjusted.</p> </div>

13.6 MARBLE MAINTENANCE

THE WORST ENEMIES OF MARBLE ARE:

Some substances damage marble more than others.

Keeping them away from surfaces, or at least removing them promptly as soon as they come into contact with the marble is very important if you want to preserve its appearance.

The worst enemies of marble surfaces are:

1. **Water:** a enemy of marble, especially that with a high presence of limestone. If it settles on marble surfaces and is not dried, it can ruin them in the long run.
2. **Coffee, wine and dyes:** as dark substances, coffee, wine and other food dyes can damage marble when they come into contact with it.
3. **Tomato sauce:** tomato sauce, when it stains, is very difficult to remove, and the same applies to marble.
4. **Polishing wax:** marble should be polished from time to time, but never apply too much wax to avoid risking obtaining the opposite effect, i.e. making it dull.
5. **Sugary substances:** fruit, juices and sweet substances, if deposited on marble, can corrode it, ruining its natural lustre. If they accidentally fall on the marble, they need to be cleaned quickly.

HOW TO CLEAN MARBLE:

1. **Damp cloth:** If the stain to be removed is not particularly stubborn, a damp cloth can be used to clean marble surfaces and achieve an excellent effect.
It is important to always remember to dry the surface, otherwise, lime-scale will damage it.
2. **Marseille soap:** Marseille soap is also perfect for cleaning marble surfaces. Lightly dampen a cloth and rub it lightly on the soap, then wipe the marble. After rinsing, carefully dry the surface, which will look as good as new.

3. **Hydrogen peroxide:** Hydrogen peroxide is another product that can have infinite uses, including cleaning marble.
Put a drop of hydrogen peroxide on a damp cloth and rub it on the marble surface to quickly restore its shine.
4. **Baking soda:** Baking soda is another useful substance for cleaning marble.
Put a tablespoon of baking soda in a glass or container and mix. The resulting compound is a slightly abrasive paste that will penetrate the marble, freeing it from foreign substances, the stains.
Baking soda is also perfect for polishing, so the marble will look shinier after the treatment.
5. **Detergents for marble:** On the market, you can find numerous special detergents for cleaning marble surfaces.
They are very useful for those who have large marble surfaces to wash, such as floors.
Make sure that the detergent is not too acidic and aggressive, or the surface will be weakened over time and more susceptible to stains.

HOW NOT TO CLEAN MARBLE:



CAUTION

Do not use generic household cleaners of any kind.

Cleaning marble with products purchased in non-specialised shops that contain acids, alkalis and other chemicals can mark or damage the surface, leaving the stone more vulnerable to staining.

The most common and popular household cleaners are too aggressive for use on marble and can cause damage.

Trying to save time by using low-end products such as general surface cleaners will only lead to expensive repairs or marble restoration.

**CAUTION**

Do not use vinegar, ammonia or lemon juice.

Powders and even “soft” creams contain abrasives that can scratch and dull the surface.

Detergent soap scum and water are the main contributors to bathroom wear. Use only specific detergents for marble to avoid most marble cleaning problems.

**CAUTION**

Do not place toiletry products on the worktop.

Hair products, toothpaste, perfumes, colognes, nail products, creams, lotions and potions can stain or mark the surface leaving dots, rings or dull areas.

Protect surfaces by making sure these products do not come into contact with the marble.

13.7 SPEED MULTISENSOR (LOG) MAINTENANCE

Component	Maintenance	Notes and precautions
LOG - speed multisensor with valve	Regular check - Ordinary Maintenance	<p>As indicated in the Manufacturer's manual.</p> <div style="border: 1px solid black; padding: 5px; margin-top: 10px;"> <p style="text-align: center;">MAINTENANCE</p> <p>At least once every six months check the correct operation. At least once every six months check the connection of the cables. At least once every six months check the propeller and grease the outer Log.</p> </div>

Riva

102 CORSARO *supera*

TROUBLESHOOTING

CHAPTER 14

14.1 TROUBLESHOOTING

The yacht is equipped with a large number of complex devices and installations. These require regular checks and maintenance to keep their operation correct.

One of the factors that might lead to problems or faults, is usually the irregular use of the yacht and, as a consequence of this, of the on-board devices. Experience has shown that the regular use of the devices normally means fewer problems and, therefore, we recommend regularly operating all on-board devices for short periods.

When an on-board problem is detected, it is essential to carry out a quick check in order to understand its cause and, if possible, to find a remedy. In order to analyse a malfunction it is appropriate to ask the following questions:

- Is the malfunction caused by a human error?
- Is the malfunction due to bad weather conditions?
- Is the malfunction due to a device failure or to a fault of another external device, but in some way connected to the first one?
- At what stage does the malfunction occur: at the start, at steady state, at device switch OFF?
- Does the malfunction occur repeatedly; if yes in which way?
- What does the malfunction imply from an operating point of view?
- Does the malfunction trigger any signals (luminous and/ or acoustic: sirens, buzzers, etc.) and/or messages on a display and/or anomalous noises (like whistles, beats, buzzes, etc..) and/or anomalous smells (burning smell)?
- Does the malfunction interfere with the operation of other devices?
- Is the malfunction a real apparent fault (that is, it can be cleared after a device reset and following switch ON)?

The best, most complete answer we can give to the previous questions, will give us a malfunction analysis.

This section of the Manual analyses the most likely causes, that may lead to the malfunctioning of a component of the main components/devices on board. For any possible analysed cause, a corrective action is advised, in order provide a solution to the problem that is as effective as possible.



WARNING

We recommend, in order to operate with peace of mind, in full safety, taking good note of the Safety Rules relevant to Maintenance described in the "SAFETY RULES".



WARNING

Corrective actions may only be carried out by specialised and authorised personnel.

RIVA declines all responsibility for proposed corrective actions carried out by unskilled personnel.



CAUTION

For more detailed information, please refer to the various Manufacturer's Service Departments or contact the RIVA After Sales & Service Department directly.

14.2 PROPULSION ENGINES

For further information, please contact the RIVA After Sales & Service Department.

Problem	Cause	Corrective action
<p>1. Engine does not turn when starter is actuated</p> <ul style="list-style-type: none"> • Battery • Starter • Engine wiring • LOP Local Operation Panel • ECU Engine Control Unit • Engine • Start-interlock limit switch 	<ul style="list-style-type: none"> • Low or defective • Cable connections defective • Engine wiring or starter defective • Faulty • Loose seating of assemblies or connectors • Loose plug-in connections • Gear locked (engine cannot start manually) • Limit switch not installed or defective • Wiring defective 	<ul style="list-style-type: none"> • Charge or replace (see Manufacturer’s documentation) • Check that cable connections are properly secured (see Manufacturer’s documentation) • Check that cable connections are properly secured, contact Service • Contact Service Department • Visual inspection • Check plug-in connections • Contact Service Department • Check limit switch • Check wiring
<p>2. Engine turns but does not fire</p> <ul style="list-style-type: none"> • Starter • Engine wiring • Fuel system • ECU Engine Control Unit 	<ul style="list-style-type: none"> • Poor or defective starter rotation • Faulty • Not vented • Faulty 	<ul style="list-style-type: none"> • Charge or replace battery (see Manufacturer’s documentation) • Contact Service Department • Check vent • Contact Service Department

Problem	Cause	Corrective action
<p>3. Engine fires unevenly</p> <ul style="list-style-type: none"> • Fuel injection equipment • Engine wiring • Fuel system • ECU Engine Control Unit 	<ul style="list-style-type: none"> • Injector defective • Faulty • Not vented • Faulty 	<ul style="list-style-type: none"> • Replace • Contact Service Department • Check vent • Contact Service Department
<p>4. Engine does not reach full-load speed</p> <ul style="list-style-type: none"> • Fuel supply • Air supply • Fuel injection equipment • Engine wiring • Yacht • Rudder • Propeller 	<ul style="list-style-type: none"> • Shut OFF • Fuel pre-filter clogged (water/fuel separator) • Fuel filter clogged • Air filter clogged • Injector defective • Injection pump defective • Faulty • Yacht too heavy • Yacht's trim position • Marine growths on hull, propeller shaft, propeller, rudder • Rudder position • After propeller replacement: propeller too small/large 	<ul style="list-style-type: none"> • Open shut-OFF valve before fuel pre-filter (water/fuel separator) • Replace • Replace • Check air cleaner clogging indicator • Replace • Replace • Contact Service Department • Check yacht's load condition, reduce load if necessary • Trim yacht • Clean • Clean • Align rudder • Replace only with original spares

Problem	Cause	Corrective action
<p>5. Engine speed not steady</p> <ul style="list-style-type: none"> • Fuel injection equipment • Speed sensor • Fuel system • Engine Control Unit 	<ul style="list-style-type: none"> • Injector defective • Injection pump defective • Faulty • Not vented • Faulty 	<ul style="list-style-type: none"> • Replace • Replace • Contact Service Department • Vent • Contact Service Department
<p>6. Charge-air temperature too high</p> <ul style="list-style-type: none"> • Coolant • Intercooler • Engine room 	<ul style="list-style-type: none"> • Incorrect coolant concentration • Contaminated • Air intake temperature too high 	<ul style="list-style-type: none"> • Check coolant properties • Contact Service Department • Check fans and ventilation air supply
<p>7. Charge air pressure too low</p> <ul style="list-style-type: none"> • Air supply • Intercooler • Turbo charger exhaust 	<ul style="list-style-type: none"> • Air filter clogged • Contaminated • Faulty 	<ul style="list-style-type: none"> • Check air filter clogging indicator • Contact Service Department • Contact Service Department
<p>8. Coolant leaks from intercooler</p> <ul style="list-style-type: none"> • Intercooler 	<ul style="list-style-type: none"> • Leaking, major coolant discharge 	<ul style="list-style-type: none"> • Contact Service Department
<p>9. Exhaust gas black</p> <ul style="list-style-type: none"> • Air supply • Fuel injection equipment • Yacht 	<ul style="list-style-type: none"> • Air filter clogged • Injector defective • Injection pump defective • Overload 	<ul style="list-style-type: none"> • Check air filter clogging indicator • Replace • Replace • Contact Service Department

Problem	Cause	Corrective action
<p>10. Blue exhaust gas</p> <ul style="list-style-type: none"> • Engine oil • Exhaust turbocharger, piston rings, cylinder liner 	<ul style="list-style-type: none"> • Too much oil in engine • Oil separator clogged • Faulty 	<ul style="list-style-type: none"> • Drain engine oil • Replace • Contact Service Department
<p>11. White exhaust gas</p> <ul style="list-style-type: none"> • Engine • Fuel system • Intercooler 	<ul style="list-style-type: none"> • Not at operating temperature • Water in fuel • Leaking 	<ul style="list-style-type: none"> • Run engine to reach operating temperature • Check fuel pre-filter (water/fuel separator filter) and drain pre-filter • Contact Service Department

14.3 GEAR BOX

For further information, please contact the RIVA After Sales & Service Department.

Problem	Cause	Corrective action
1. Transmission oil temperature too high	<ul style="list-style-type: none"> • Insufficient water flows through oil heat exchanger • Drain sludge from oil cooler • Undefined range, clutch slipping 	<ul style="list-style-type: none"> • Increase water flow • Clean oil cooler • Adjust mechanism
2. Transmission oil temperature too low	<ul style="list-style-type: none"> • Excessive water flow through heater exchanger 	<ul style="list-style-type: none"> • Reduce water flow
3. Oil pressure upstream of oil cooler and filter too high (*)	<ul style="list-style-type: none"> • Clogged oil filter • Oil cooler dirty 	<ul style="list-style-type: none"> • Clean filter and drain off oil sludge • Clean oil side of oil cooler
4. No operating oil pressure (*)	<ul style="list-style-type: none"> • No oil in transmission • Wrong rotation direction at transmission input • Faulty display unit 	<ul style="list-style-type: none"> • Add oil • Use special transmission version • Remedy fault
5. Operating oil pressure too low (*)	<ul style="list-style-type: none"> • Oil viscosity too low • Incorrect oil pump ratio • Defective oil pump • Pressure relief valve leaking • Timeswitch for pressure modulation defective 	<ul style="list-style-type: none"> • Use a prescribed oil grade • Adjust oil pump ratio to suit engine operating speed range • Replace oil pump • Remedy the fault • See Manufacturer's documents

(*) see monitoring data.

Problem	Cause	Corrective action
6. Operating oil pressure too high (*)	<ul style="list-style-type: none"> • Oil viscosity too high • Incorrect oil pump ratio 	<ul style="list-style-type: none"> • Use a prescribed oil grade • Adjust oil pump ratio to suit engine operating speed range.
7. Drive interrupted between transmission input and transmission output; clutch not transmitting torque	<ul style="list-style-type: none"> • Mechanical transmission actuation: incorrect shift angle • Electrical transmission actuation: electrical system fault • Defective solenoid valve • Longitudinal valve stuck • No operating oil pressure 	<ul style="list-style-type: none"> • Adjust setting • Remedy electrical system fault • Replace • Remedy fault • See “No operating oil pressure” or “Oil pressure too low”
8. Drive between transmission input and transmission output cannot be interrupted; clutch does not disengage	<ul style="list-style-type: none"> • For possible causes and remedial actions, see “clutch not transmitting torque” fault 	<ul style="list-style-type: none"> • Use a prescribed oil grade • Adjust oil pump ratio to suit engine operating speed range
9. Clutch slips at high engine speed	<ul style="list-style-type: none"> • Operating oil pressure too low (*) 	<ul style="list-style-type: none"> • See remedy for “Operating oil pressure too low”. If the fault cannot be remedied on board, proceed at reduced engine speed - so that the clutch does not slip - until repairs can be carried out. Avoid changes in direction or only change direction with the propeller almost at a standstill and with engine idle speed as low as possible
10. Oil level decreases rapidly (as indicated on the dipstick). See maintenance job “Oil level check”	<ul style="list-style-type: none"> • Leaks on housing joints or oil lines, oil escaping from shaft seals • Oil cooler leaking into cooling system 	<ul style="list-style-type: none"> • Correct mechanical fault • Remedy fault, replace oil cooler if necessary

(*) see monitoring data.

Problem	Cause	Corrective action
11. Oil level increases. See maintenance job "Oil level check"	<ul style="list-style-type: none"> Water entering the oil circuit from the cooling system 	<ul style="list-style-type: none"> Correct mechanical fault
12. Transmission is too loud at certain speed ranges	<ul style="list-style-type: none"> Torsional vibration resonance of propulsion system in engine idle speed range 	<ul style="list-style-type: none"> Avoid critical speed range. Use more suitable flexible coupling (see Manufacturer's document)
13. Transmission too loud at engine idle speed range	<ul style="list-style-type: none"> Torsional vibration resonance of propulsion system in engine idle speed range 	<ul style="list-style-type: none"> Increase engine idle speed range
14. Engine stalls following rapid change from "Ahead" to "Astern"	<ul style="list-style-type: none"> Engine idle speed too low Change in direction made too quickly or made at excessive craft speed 	<ul style="list-style-type: none"> Increase engine idle speed range Change direction (see Manufacturer's document)

If the fault cannot be remedied, the transmission lubricating oil supply is also at risk. Proceed at reduced engine speed only until repairs can be carried out.

14.4 GENERATORS

For further information, please contact the RIVA After Sales & Service Department.

Problem	Cause	Corrective action
1. Fluctuating or low oil pressure	<ul style="list-style-type: none"> • Oil level too low • Dirty oil 	<ul style="list-style-type: none"> • Stop the generator immediately and top up with suitable oil • Replace dirty oil with new suitable oil
2. Cooling water temperature too high	<ul style="list-style-type: none"> • Excessive load • Air in the cooling circuit • Coolant low level or wrong mixture • Sea water intake is obstructed or sea water intake strainer is clogged 	<ul style="list-style-type: none"> • Reduce the load • Bleed the circuit • Restore the cooling water level and correct percentage • Clean sea cock and strainer
3. Black smoke	<ul style="list-style-type: none"> • Engine room insufficient ventilation • Excessive load • Unsuitable fuel • Cooling water temperature too high • Lack of maintenance 	<ul style="list-style-type: none"> • Check that air intakes are not obstructed • Reduce the load • Replace with suitable fuel • See step 2 • Have the scheduled maintenance operations carried out

Problem	Cause	Corrective action
<p>4. Blue smoke</p>	<ul style="list-style-type: none"> • Excessive oil • Dirty oil • Lack of maintenance 	<ul style="list-style-type: none"> • Discharge the excess oil by draining oil filters • Replace dirty oil with new suitable oil • Have the scheduled maintenance operations carried out
<p>5. White smoke</p>	<ul style="list-style-type: none"> • Cold generator • Generator with too low load 	<ul style="list-style-type: none"> • Let the generator warm up • Increase the generator load
<p>6. Lack of power</p>	<ul style="list-style-type: none"> • Engine room insufficient ventilation • Fuel filter clogged • Unsuitable fuel • Cooling water temperature too high • Lack of maintenance 	<ul style="list-style-type: none"> • Check that air intakes are not obstructed • Clean • Replace with suitable fuel • See step 2 • Have the scheduled maintenance operations carried out
<p>7. Excessive or unusual noise</p>	<ul style="list-style-type: none"> • Insulation cover not properly fastened • Leakage from the exhaust • Exhaust not properly fastened • Lack of maintenance 	<ul style="list-style-type: none"> • Check • Check the exhaust • Check the exhaust • Have the scheduled maintenance operations carried out

14.5 BATTERY CHARGER

For further information, please contact the RIVA After Sales & Service Department.

Problem	Cause	Corrective action
<p>1. No inverter output voltage. The inverter does not work, or just for a few seconds</p>	<ul style="list-style-type: none"> • Battery voltage may be too low. Low voltage cut-out switch trips at 10 V (12 V), 20 V (24 V) or 40 V (48 V). • Battery connections are corroded • Check if the inverter is overheated. In case of overheating LED of temperature + failure lights up • Overload or short circuit • LED overload + failure will be lit 	<ul style="list-style-type: none"> • Recharge battery for 24 hrs • Check for corrosion, and replace bad sections • Disconnectconnected load. Improve ventilation • Disconnect excessive load • Remove short circuit condition
<p>2. Battery charger does not operate</p>	<ul style="list-style-type: none"> • AC voltage not supplied • Input voltage too low • The battery charger will not operate below 160/80 V 	<ul style="list-style-type: none"> • Check system • The AC green LED should light up, if power is supplied • Check fuses or magneto-thermals • Check the generator output voltage, remove connected load, output voltage should come up
<p>3. The battery charger does not operate, while mains voltage is present</p>	<ul style="list-style-type: none"> • Mains frequency could be too high or too low • The frequency must be within 35-66 Hz 	<ul style="list-style-type: none"> • Check the generator output frequency • Check generator rpm

Problem	Cause	Corrective action
4. Batteries not fully charged	<ul style="list-style-type: none"> • Charge current too low • Current to load too high • Charge time too short • Battery temperature too low • Defective battery (short circuit in cell) 	<ul style="list-style-type: none"> • See “charge current too low” • Decrease the battery load • Replace the battery • Use temperature sensor • Replace the battery
5. Battery loses charge quickly	<ul style="list-style-type: none"> • Battery capacity reduced because: <ul style="list-style-type: none"> - Wastage - Sulphating/stagnation 	<ul style="list-style-type: none"> • Replace batteries • Charge/discharge several times, this might help, otherwise replace batteries
6. Batteries are warm	<ul style="list-style-type: none"> • Defective batteries (short circuit in cell) • Battery temperature too high • Charge voltage too high 	<ul style="list-style-type: none"> • Replace batteries • Use temperature sensor • Check the switches setting

14.6 INVERTER

For further information, please contact the RIVA After Sales & Service Department.

Problem	Cause	Corrective action
<p>1. No output voltage and no lighting of warning lights (LED OFF)</p>	<ul style="list-style-type: none"> • High output voltage • DC fuse burnt out • Switch set on remote control, but this is not available 	<ul style="list-style-type: none"> • Check the battery voltage and switch off the charger • Replace the fuse • Place the switch to ON
<p>2. No voltage in output, LED of battery charge is ON</p>	<ul style="list-style-type: none"> • Batteries flat 	<ul style="list-style-type: none"> • Charge the batteries, the inverter will switch on when the battery voltage exceeds 24 V
<p>3. No voltage in output, temperature LED ON</p>	<ul style="list-style-type: none"> • The inverter is overloaded 	<ul style="list-style-type: none"> • Reduce the charge and let the inverter cool down
<p>4. No output voltage, LED "ON" is lit</p>	<ul style="list-style-type: none"> • Inverter is in stand-by 	<ul style="list-style-type: none"> • Connect a charge or modify the jumper's settings
<p>5. Low voltage in output</p>	<ul style="list-style-type: none"> • Low power supply = jumper adjustment 	<ul style="list-style-type: none"> • Connect a charge > 30 W or modify the jumper's settings
<p>6. The inverter turns on and off, the "ON" LED and the battery charger LED flash in turns</p>	<ul style="list-style-type: none"> • Batteries flat • Wires are too thin • The connections are corroded or faulty 	<ul style="list-style-type: none"> • Disconnect the charge and charge the batteries • Replace with wires of correct diameter • Tighten connections. If wires are burnt out, replace them
<p>7. The inverter lights ON/OFF, the ON LED is lit, the "overload" LED flashes once a second and the fan operates at full speed.</p>	<ul style="list-style-type: none"> • The inverter is overloaded • The inverter has been switched off ten times as a result of an overload or short-circuit condition. 	<ul style="list-style-type: none"> • Reduce the inverter load • Reduce the load or the short-circuit. Reset the inverter manually through ON/OFF switch

14.7 USES

For further information, please contact the RIVA After Sales & Service Department.

Problem	Cause	Corrective action
1. A connected utility will not receive power supply	<ul style="list-style-type: none"> • Power line fuses blown • Wiring disconnected • Connections oxidised maintenance 	<ul style="list-style-type: none"> • Check the line and replace the fuses • Check wiring connections • Check and carry out proper maintenance

14.8 FUEL SYSTEM

For further information, please contact the RIVA After Sales & Service Department.

Problem	Cause	Corrective action
1. Irregular fuel supply to engines and generators and engines	<ul style="list-style-type: none">• Circuit valves closed or not fully open• Filters clogged	<ul style="list-style-type: none">• Check/Open• Clean

14.9 BLACK OR GREY WATER DRAINING SYSTEM

For further information, please contact the RIVA After Sales & Service Department.

Problem	Cause	Corrective action
<p>1. Holding tank or grey water tank drain irregular</p>	<ul style="list-style-type: none"> • Circuit valves closed or not fully open • Lack of maintenance • Abnormal pump operation 	<ul style="list-style-type: none"> • Check/open • Carry out maintenance • Check

14.10 FRESH WATER SYSTEM

For further information, please contact the RIVA After Sales & Service Department.

Problem	Cause	Corrective action
<p>1. No water to outlets</p>	<ul style="list-style-type: none"> • Circuit valves closed or not fully open • Tanks empty • Pump not receiving electric power supply • Protection pump mode 	<ul style="list-style-type: none"> • Check/open • Fill the tanks and bleed the circuit • Check • Reset
<p>2. Pump starts even with outlets closed</p>	<ul style="list-style-type: none"> • Circuit leaking 	<ul style="list-style-type: none"> • Eliminate leakage
<p>3. The pump gets continuously ON/OFF</p>	<ul style="list-style-type: none"> • The tank has no air inside the membrane 	<ul style="list-style-type: none"> • Contact the Service Department

14.10.1 Watermaker

For further information, please contact the RIVA After Sales & Service Department.

Problem	Cause	Corrective action
<p>1. The pump runs but can't reach the pressure as indicated</p>	<ul style="list-style-type: none"> • The pump sucks air • Worn valves • Worn seat of pressure relief valve • Improper or worn nozzle • Worn gaskets 	<ul style="list-style-type: none"> • Check the intake pipes. They must be well air-tight • Check and/or replace • Check and clean • Check and/or replace • Check and/or replace
<p>2. Irregular pressure variations</p>	<ul style="list-style-type: none"> • Worn intake and/or pressure relief valve • Presence of foreign bodies in valves • Air suction • Worn gaskets • Relief valve too open 	<ul style="list-style-type: none"> • Check and/or replace • Check and clean • Check intake pipes • Check and/or replace • Close the valve nut clockwise
<p>3. Drop in pressure</p>	<ul style="list-style-type: none"> • Worn nozzle • Worn intake and/or pressure relief valve • Presence of foreign bodies in valves 	<ul style="list-style-type: none"> • Replace • Check and/or replace • Check and clean
<p>4. Noise</p>	<ul style="list-style-type: none"> • Air suction • Broken or unloaded spring of intake and/ or pressure valves • Presence of foreign matters • Worn bearings • Exceeding temperatures of pumped fluid 	<ul style="list-style-type: none"> • Check the suction pipes are well air-tight • Check and clean • Check and clean valves • Replace • Decrease the temperature

14.11 BILGE PUMPS

For further information, please contact the RIVA After Sales & Service Department.

Problem	Cause	Corrective action
<p>1. Bilge pump does not run. No water pumped</p>	<ul style="list-style-type: none"> • Wire connections • Blown fuse 	<ul style="list-style-type: none"> • Check wire connection integrity, make sure wire connections are not corroded • A visual check may not be enough, a slight pull on each wire will indicate if wires are still connected • Check to ensure that no wire joints are hanging down into the water • Check the correct fuse size (fuse size is printed on the side of the bilge pump) • If fuse size is correct, check the impeller through the inlet opening to be sure it is not jammed or stuck with debris
<p>2. Repeated blown fuse</p>	<ul style="list-style-type: none"> • Fuse rating or clogged impeller 	<ul style="list-style-type: none"> • Re-check fuse to verify compliance to pump specifications • Also examine impeller area & clean any obstructions
<p>3. Pump runs without water output</p>	<ul style="list-style-type: none"> • Airlocking/cavitating • Pump strainer & impeller area clogged with debris 	<ul style="list-style-type: none"> • Inspect & reposition hose for short vertical discharge • We suggest installing pump below water line to ensure sufficient water flow • Faulty or clogged check valve may add to pump air locking • Disconnect pump & clean outside of strainer, clean debris around impeller, & reattached & re-hook wiring

Problem	Cause	Corrective action
4. Pump shaft corroded	<ul style="list-style-type: none"> Electrolysis, cracked housing 	<ul style="list-style-type: none"> Inspect pump housing for cracks which can cause leakage into motor cavity causing corrosion Possible incorrect current running through wiring causing corrosion
5. Pump stays on after water is pumped out	<ul style="list-style-type: none"> Wire connections may be incorrect, automatic pumps may have faulty circuit, possible electrical short 	<ul style="list-style-type: none"> On bilge pumps check for correct positive and negative battery connections
6. Nozzle breakage	<ul style="list-style-type: none"> Hose clamp fastened too tightly 	<ul style="list-style-type: none"> Suggest using plastic style hose clamp, do not use PVC hose
7. Pump impeller spins backward	<ul style="list-style-type: none"> Check wiring 	<ul style="list-style-type: none"> Switch wiring for correct polarity
8. Wires overheated, melted insulation	<ul style="list-style-type: none"> Incorrect fuse size, possible jammed impeller 	<ul style="list-style-type: none"> Inspect & clean impeller area of any debris Make sure that impeller is free to rotate Check to make certain correct fuse rating is installed REPLACE ALL DAMAGED WIRING

14.12 HYDRO-ELECTRIC STEERING SYSTEM

For further information, please contact the RIVA After Sales & Service Department.

Problem	Cause	Corrective action
<p>1. Air bubbles or foam in the system</p>	<ul style="list-style-type: none"> • The oil level in the tank is too low and does not allow the suction pipe to be completely plunged. In this way the pump sucks oil and air at the same time • Possible openings and little holes on the suction pipes or faulty pump seals, which allow air to penetrate 	<ul style="list-style-type: none"> • Check • Check
<p>2. The pump does not deliver oil</p>	<ul style="list-style-type: none"> • Wrong rotation direction • Obstructed ducts or suction strainers • Oil level in the tank too low • Air leakages in the suction system • Oil too viscous with some difficulties in passing through • The shaft or other components of the pump are broken 	<ul style="list-style-type: none"> • Check • Check • Check • Check • Check • Replace
<p>3. Lack of pressure in the system</p>	<ul style="list-style-type: none"> • The pump does not deliver oil • Relief valve is not calibrated • Free discharge of oil to the tank somewhere in the system 	<ul style="list-style-type: none"> • Check • Check • Check

Problem	Cause	Corrective action
<p>4. The pressure of the system is low or fluctuating</p>	<ul style="list-style-type: none"> • Possible leaks in the piping or elsewhere in pressurized parts of the system • Relief valve set at a too low rate • The relief valve remains open or oscillates in its housing • Restriction of pump suction pipes or possible obstruction of filter • Air in leaks in suction pipes or by pump seals • Worn pump 	<ul style="list-style-type: none"> • Check • Check • Check • Check • Check • Check
<p>5. Pump too noisy</p>	<ul style="list-style-type: none"> • Wrong pump rotation direction • Oil with air bubbles • Oil viscosity causing obstructions to the suction system • Irregular flow of oil into the pump, caused by an insufficient filtering capacity of the filter (the filter could be dirty or not suitable) • Big lacks of charge along the suction line • Worn pump components • Relief valve vibrations • Mechanical vibrations due to bad anchor action 	<ul style="list-style-type: none"> • Check • Bleed • Check • Check/Clean • Check • Check/Replace • Check • Check

Problem	Cause	Corrective action
<p>6. Too high temperature</p>	<ul style="list-style-type: none"> • The pump is working at a higher pressure than permitted • Faulty or worn pump which causes internal leaks • Excessive blow-by through valves and cylinder • Oil too viscous • Continuous overloaded operation • Temperature too high in the room where the pump unit is placed 	<ul style="list-style-type: none"> • Check • Check • Check • Check • Check • Check
<p>7. Leaks from the seals</p>	<ul style="list-style-type: none"> • Possible abrasive substances have entered into the oil circulation, damaging the pump's shaft • Seals are faulty, broken or mounted in a wrong way • Too hot oil 	<ul style="list-style-type: none"> • Check • Check • Check
<p>8. Pump overcharging the motor</p>	<ul style="list-style-type: none"> • Too viscous oil • Obstructed delivery line or excessive resistance 	<ul style="list-style-type: none"> • Check • Check

14.13 AIR CONDITIONING SYSTEM

For further information, please contact the RIVA After Sales & Service Department.

Problem	Cause	Corrective action
1. High crankcase temperature	<ul style="list-style-type: none"> • Overheating • Poor circulation of treated water (winter cycle) or condensation water (summer cycle) 	<ul style="list-style-type: none"> • Check coolant charge • Correct circulation
2. Low suction pressure	<ul style="list-style-type: none"> • Low coolant charge • Poor circulation of condensation water (winter cycle) or treated water (summer cycle) 	<ul style="list-style-type: none"> • Add • Correct circulation
3. System noisy	<ul style="list-style-type: none"> • Loose fastening bolts • Unit base improperly insulated • Improper support or insulation of piping • Piping vibrations 	<ul style="list-style-type: none"> • Tighten bolts • Insulate foundation • Use correct piping techniques and support piping with suitable hangers • Clip pipes correctly. Check the couplings
4. Compressor does not start	<ul style="list-style-type: none"> • Power off • Thermostat misadjusted • Pressure switch open • Faulty wiring • Pumps not operating • Flow-switch does not close • Gas discharging unit 	<ul style="list-style-type: none"> • Check the supply. • Check fuses and/or magneto-thermal switches • Adjust thermostat • Reset switch and check proper calibration, 20 bar (h.p.) and 2.5 bar (l.p.) • Check diagram and rewire • Check pumps free rotation. Check the magneto-thermal switches • Restore correct treated water circulation • Check coolant circuit for possible breaks due to transport and installation

Problem	Cause	Corrective action
<p>5. Compressor cycles intermittently</p>	<ul style="list-style-type: none"> • Low pressure switch erratic in operation • Low coolant charge • Internal protection tripped 	<ul style="list-style-type: none"> • Check pressure switch setting. Check good circulation of condensed water • Add • Check for any voltage drop, correct
<p>6. High delivery pressure with compressor stop (high pressure switch).</p>	<ul style="list-style-type: none"> • Coolant overcharge • Insufficient or no condenser water flow; clogged condenser or sea-water strainer • Condensed water pump off • Poor treated water circulation (winter cycle) • Air in coolant circuit 	<ul style="list-style-type: none"> • Remove excess coolant • Adjust water regulating valve to condenser; clean condenser or sea-water strainer • Check pump and start • Check for air in the circuit. • Check for possible clogging • Restore vacuum and refill with coolant

14.14 GANGWAY

For further information, please refer to RIVA After Sales & Service Department.

Problem	Cause	Corrective action
<p>1. The system does not react to the controls</p>	<ul style="list-style-type: none"> • Flat battery • Power supply 	<ul style="list-style-type: none"> • Verify that the battery of the sender is loaded or correctly inserted • Verify that the self learning of the sender code has been carried out • Check that the hydraulic unit is correctly powered
<p>2. The gangway moves discontinuously</p>	<ul style="list-style-type: none"> • The hydraulic power unit has a thermal protection 	<ul style="list-style-type: none"> • Wait until hydraulic power unit is disconnected (about 5 minutes) and retry handling on the adjusting trimmer (shift few degrees each time), if the problem continues, also with trimmer at bottom scale (clockwise) address to service department

Riva

102 CORSARO *supera*

Riva

A FERRETTIGROUP BRAND